



Central Corridor
Light Rail Transit
 **Metropolitan Council**

Report for
Design Criteria (Revision 0)
July 2008

TABLE OF CONTENTS

1.0 GENERAL

- 1.1 PURPOSE
- 1.2 SCOPE
- 1.3 PROCEDURES
- 1.4 DESIGN CODES AND MANUALS
- 1.5 CLIMATIC CONDITIONS
- 1.6 HISTORIC PRESERVATION
- 1.7 ACRONYMS AND ABBREVIATIONS
- 1.8 UNITS OF MEASURE

2.0 FIRE/ LIFE SAFETY

- 2.1 INTRODUCTION SCOPE & DEFINITIONS
- 2.2 STATION AND SITE
- 2.3 GUIDEWAY
- 2.4 LIGHT RAIL VEHICLE (LRV)
- 2.5 SIGNALING
- 2.6 COMMUNICATIONS
- 2.7 ELECTRICAL POWER
- 2.8 YARDS AND SHOPS
- 2.9 RAIL CONTROL CENTER (RCC)
- 2.10 OPERATIONS
- 2.11 APPLICABLE STANDARDS, CODES AND GUIDELINES

3.0 TRACK GEOMETRY AND TRACKWORK

- 3.1 GENERAL
- 3.2 HORIZONTAL TRACK ALIGNMENT
- 3.3 VERTICAL TRACK ALIGNMENT
- 3.4 MAINLINE TRACK
- 3.5 YARD TRACK

4.0 UTILITIES

- 4.1 SCOPE
- 4.2 GENERAL REQUIREMENTS
- 4.3 SPECIFIC REQUIREMENTS

5.0 LANDSCAPING & URBAN DESIGN

- 5.1 GENERAL
- 5.2 OVERALL GOALS AND OBJECTIVES
- 5.3 PERFORMANCE REQUIREMENTS

6.0 STATION AREA AND FACILITY REQUIREMENTS

- 6.1 GENERAL
- 6.2 OVERALL GOALS AND OBJECTIVES
- 6.3 OVERALL PERFORMANCE REQUIREMENTS
- 6.4 CIRCULATION SYSTEMS
- 6.5 HARD SURFACE ELEMENTS
- 6.6 SITE FURNISHINGS
- 6.7 MECHANICAL SYSTEMS

- 6.8 SITE SIGNS AND GRAPHICS
- 6.9 LIGHTING
- 6.10 ADVERTISING
- 6.11 PUBLIC ART
- 6.12 STATION FACILITIES
- 6.13 MATERIALS AND FINISHES
- 6.14 CCTV

7.0 TUNNEL DESIGN

- 7.1 INTRODUCTION
- 7.2 MATERIALS
- 7.3 DESIGN LOADS
- 7.4 GROUP FACTORS, LOAD FACTORS, AND LOAD COMBINATIONS
- 7.5 ADDITIONAL CONSIDERATIONS
- 7.6 WATERPROOFING AND DRAINAGE
- 7.7 FIRE PROTECTION
- 7.8 SUPPORT AND UNDERPINNING OF EXISTING STRUCTURES

8.0 LOW-FLOOR LIGHT RAIL VEHICLE

- 8.1 GENERAL DESCRIPTION
- 8.2 CRITICAL CAR DIMENSIONS
- 8.3 WEIGHT AND PASSENGER LOADING
- 8.4 CURVES AND GRADES
- 8.5 DYNAMIC ENVELOPE
- 8.6 PROPULSION/BRAKING PERFORMANCE
- 8.7 SYSTEM OPERATIONS
- 8.8 RELIABILITY
- 8.9 MAINTAINABILITY

9.0 OPERATIONS AND MAINTENANCE FACILITY

- 9.1 DESIGN REQUIREMENTS AND GUIDELINES
- 9.2 FUNCTIONAL REQUIREMENTS
- 9.3 SITE PLANNING
- 9.4 YARD
- 9.5 LRV MAIN SHOP

10.0 TRACTION ELECTRIFICATION SYSTEM

- 10.1 INTRODUCTION
- 10.2 FUNCTIONAL REQUIREMENTS
- 10.3 STANDARDS AND CODES
- 10.4 SYSTEM LOAD FLOW STUDY
- 10.5 TRACTION POWER SUPPLY SYSTEM
- 10.6 OVERHEAD CONTACT SYSTEM
- 10.7 DESIGN PARAMETERS

11.0 ELECTRICAL SYSTEMS

- 11.1 INTRODUCTION
- 11.2 ELECTRICAL REQUIREMENTS
- 11.3 TRACTION POWER SUBSTATIONS
- 11.4 EMERGENCY POWER SYSTEMS
- 11.5 LIGHTING

- 11.6 SYSTEMWIDE GROUNDING
- 11.7 CONDUIT AND DUCTBANKS
- 11.8 PLATFORM HEATING

12.0 SIGNAL SYSTEM

- 12.1 GENERAL DESCRIPTION
- 12.2 AUTOMATIC TRAIN PROTECTION
- 12.3 INTERLOCKINGS
- 12.4 ROADWAY GRADE CROSSING WARNING
- 12.5 TRAIN-TO-WAYSIDE COMMUNICATIONS (TWC) SYSTEM
- 12.6 STANDARDS AND CODES
- 12.7 SAFETY DESIGN
- 12.8 HEADWAYS AND BLOCK LAYOUT
- 12.9 SAFE BRAKING DISTANCE
- 12.10 ENVIRONMENTAL CONSIDERATIONS
- 12.11 SERVICE PROVEN EQUIPMENT AND DESIGN
- 12.12 TRAIN DETECTION
- 12.13 SIGNALS & SWITCH INDICATORS
- 12.14 MAINLINE TRACK SWITCHES
- 12.15 CONTROL CIRCUITRY
- 12.16 SIGNAL POWER
- 12.17 LOCAL CONTROL PANELS
- 12.18 EVENT RECORDERS
- 12.19 SCADA INTERFACE TERMINAL BLOCK
- 12.20 LIGHTNING AND TRANSIENT PROTECTION
- 12.21 WIRE AND CABLE
- 12.22 LOCATION OF SIGNAL EQUIPMENT

13.0 COMMUNICATIONS & CENTRAL CONTROL

- 13.1 GENERAL
- 13.2 STANDARDS AND CODES
- 13.3 CONTROL CENTER
- 13.4 CCS/SCADA
- 13.5 RADIO SYSTEM
- 13.6 TELEPHONE SYSTEM
- 13.7 CCTV SURVEILLANCE SYSTEM
- 13.8 PUBLIC ADDRESS SYSTEM
- 13.9 CABLE TRANSMISSION SYSTEM
- 13.10 IS (INFORMATION SYSTEM) LAN
- 13.11 TICKET VENDING MACHINE LAN
- 13.12 TWC DATA CIRCUITS
- 13.13 TUNNEL COMMAND POST
- 13.14 LOCATION OF COMMUNICATION EQUIPMENT
- 13.15 SECURITY SYSTEMS INTRUSION DETECTION
- 13.16 SPECIAL REQUIREMENTS
- 13.17 LIGHTNING, TRANSIENT PROTECTION, AND GROUNDING

14.0 STRAY CURRENT/CORROSION CONTROL

- 14.1 PURPOSE
- 14.2 SOIL CORROSION CONTROL
- 14.3 STRAY CURRENT CORROSION CONTROL
- 14.4 CORROSION CONTROL COATINGS
- 14.5 GROUNDING COORDINATION

15.0 FARE COLLECTION SYSTEM

- 15.1 GENERAL
- 15.2 INFRASTRUCTURE NEEDS
- 15.3 SCHEDULE SUPPORT

16.0 CIVIL ENGINEERING

- 16.1 GENERAL
- 16.2 CONTROL SURVEY
- 16.3 CLEARANCES
- 16.4 STREET DESIGN
- 16.5 DRAINAGE
- 16.6 PARK-AND-RIDE LOTS
- 16.7 BICYCLE FACILITIES

17.0 TRAFFIC ENGINEERING

- 17.1 TRAFFIC SIGNAL SYSTEMS
- 17.2 TRAFFIC SIGNS AND PAVEMENT MARKINGS

18.0 STRUCTURES

- 18.1 GENERAL
- 18.2 DESIGN CODES, MANUALS, AND SPECIFICATIONS
- 18.3 MATERIALS
- 18.4 LOADS AND FORCES
- 18.5 SPECIAL REQUIREMENTS FOR TRANSPORTATION STRUCTURES
- 18.6 SPECIAL REQUIREMENTS FOR BUILDINGS AND OTHER
NON-TRANSPORTATION STRUCTURES
- 18.7 DETAILING AND PLAN REQUIREMENTS

APPENDIX

- APPENDIX A LOW FLOOR VEHICLE DYNAMIC CLEARANCE PROGRAM –
 HORIZONTAL OFFSETS AND DISPLACEMENTS

- APPENDIX B VEHICLE DYNAMIC ENVELOPE

1.0 GENERAL

1.1 PURPOSE

This part establishes basic design criteria to be used in the design of the Central Corridor Light Rail Transit (CCLRT) System. Standard and directive drawings will be prepared during preliminary engineering and final design to standardize and guide the design activities and preparation of procurement and construction documents.

Design is to be directed toward optimizing the design including considerations such as costs for design, construction, capital facilities; operating expense; energy consumption; and minimizing disruption of local facilities and communities; and meeting aesthetics, community, and local agency standards. It should be consistent with passenger safety, system reliability, service comfort, mode of operation, type of LRT vehicle to be used and maintenance considerations.

1.2 SCOPE

These Design Criteria, which refer to the most recent addition of the State of Minnesota Building Codes, will take precedence over all other standards referred to herein except those fixed by legislation.

Specific attention should be given to Final Rule of the U.S. Department of Transportation regarding Transportation for Individuals with Disabilities, published in the Federal Register of September 6, 1991, and to any subsequent modifications that may be issued. The applicability of that document is noted in several sections of this design criteria manual where it appears to be particularly appropriate. However, the regulations must be adhered to in all areas, whether or not mentioned here.

The performance and design criteria in this part relate to the following LRT facility and system elements:

- Fire/Life Safety;
- Track Geometry and Trackwork;
- Utilities;
- Landscaping and Urban Design;
- Stations;
- Tunnel Alignment Structures;
- Light Rail Vehicles;
- Operations and Maintenance Facilities;
- Traction Electrification System;
- Signal System;
- Communications and Central Control;
- Fare Collection;
- Civil Engineering;
- Traffic Engineering; and
- Structural Engineering.

1.3 PROCEDURES

Drawings and technical specifications shall be prepared for the project in accordance with these design criteria and CCPO LRT Design Standards as established during the design and construction of the Central Corridor LRT project. All drawings and technical specifications shall be prepared in accordance with the Project's Quality Assurance Plan (QAP)

Deviations may be made within the framework of these Design Criteria to meet the requirements of a particular problem. However, any deviation, discrepancy, or unusual solution must be approved by the Central Corridor Project Office (CCPO) before it can be included in the design. It is the responsibility of the Designer to identify, explain, and justify any deviation from the established criteria and to secure the necessary approvals from the CCPO.

As this Part is revised, modified, or augmented, the Revision Records for each section will show the page number, date, and appropriate section decimal notation for each change or addition. Individual pages will also indicate the revision date and page number. Proposals for revisions shall be directed to the CCPO for approval.

1.4 DESIGN CODES AND MANUALS

In addition to these criteria, the Designer must comply with all other applicable engineering codes and standards, including those of the various federal, state, and local jurisdictions.

If codes and/or manuals are specified herein for the design of an element of Central Corridor LRT system, then the edition(s) in effect at the time of contract award shall be used.

Specific codes and standards include, but are not limited to, the following:

- Americans with Disabilities Act (ADA);
- US Department of Transportation Final Rule - Transportation for Individuals with Disabilities;
- Minnesota Department of Transportation Standard Reference Manuals;
- City of Saint Paul Standards
- Ramsey County Standards
- Hennepin County Standards
- City of Minneapolis Standards;
- Capitol Area Architectural and Planning Board (CAAPB) Comprehensive Plan and Design Criteria
- Manual on Uniform Traffic Control Devices for Streets and Highways;
- Minnesota Manual on Uniform Traffic Control Devices;
- State of Minnesota Uniform Building Code;
- State of Minnesota Sustainable Building Guidelines (MSBG);
- Standard Specifications for Highway Bridges, American Association of State Highway and Transportation Officials (AASHTO);
- Manual for Railway Engineering, American Railway Engineering and Maintenance of Way Association (AREMA);
- Steel Construction Manual, American Institute of Steel Construction (AISC);

-
- Structural Welding Code and Bridge Welding Code, American Welding Society (AWS);
 - Building Code and Commentary, American Concrete Institute (ACI);
 - American Society for Testing and Materials, American Society for the Testing of Materials (ASTM);
 - National Bureau of Standards;
 - National Electrical Code (NEC);
 - American National Standards Institute (ANSI);
 - Standard Specifications for Structural Support for Highway Signs, Luminaries, and Traffic Signals, American Association of State Highway and Transportation Officials (AASHTO);
 - AASHTO LRFD Bridge Design Specifications, 4th Edition and Current Interims
 - AASHTO Manual for Condition Evaluation of Bridges, Second Edition, 1994 and Current Interims;
 - AASHTO Guide Specification for Pedestrian Bridges, 1st Edition;
 - AASHTO Guide Specification and Commentary for Vessel Collision Design of Highway Bridges.
 - Manual of Maintenance Inspection of Bridges, American Association of State Highway and Transportation Officials;
 - Building Code Requirements for Reinforced Concrete, American Concrete Institute Committee 318 (ACI);
 - Uniform Building Code, International Conference of Building Officials (UBC);
 - Proposed National Forest Products Association Standards for Fixed Guideway Transit Systems, National Forest Products Association;
 - Building Code Requirements for Structural Plain Concrete, American Concrete Institute (ACI 322) ;
 - Code for Safety to Life in Building and Structures, National Fire Protection Association (NFPA);
 - Guide Design Specification for Bridge Temporary Works, American Association of State Highway and Transportation Officials;
 - National Design Specification for Wood Construction, National Forest Products Association;
 - Guide Specifications for Structural Design of Sound Barriers, American Association of State Highway and Transportation Officials;
 - American Society of Heating, Refrigeration and Air Conditioning Engineers (ASHRAE);
 - American Society of Mechanical Engineers (ASME);
 - Uniform Fire Code (UFC); and
 - Guidelines for the Operation of Traffic Signals near Railroad Grade Crossings, Institute of Transportation Engineers (ITE).

1.5 CLIMATIC CONDITIONS

The project is located within the cities of Saint Paul and Minneapolis, Ramsey and Hennepin Counties. The area climate is classified as humid continental with year-round precipitation and warm summers. Weather extremes occur as the area experiences four distinct seasons. Throughout the year St. Paul and Minneapolis

are subject to severe storms including blizzards, freezing rain, tornadoes, wind, and hail. Heavy fog is rare.

The following environmental conditions have been recorded and reported by the National Climatic Data Center (NCDC):

Temperature

Minimum temperature	-34°F
Maximum temperature	108°F
Average January temperature	13°F
Average July temperature	73°F

Precipitation

Maximum Rainfall	10.00 inches/24 hours
Maximum Snowfall	21.00 inches/24 hours
Average Annual Rainfall	27.16 inches
Average Annual Snowfall	49.2 inches
Highest Average Snowfall occurs in January with 9.8 inches	
Highest Average Rainfall occurs in June with 4.17 inches	

Wind Speed

Observed Average one-minute value	51 mph
Peak Gust	71 mph
Average January Wind Speed	10.5 mph
Average July Wind Speed	9.5 mph

Cloudiness

Number of Days of Clear Skies	96 days
-------------------------------	---------

1.6 HISTORIC PRESERVATION

Requirements to be provided at the time of the Programmatic Agreement among the Federal Transit Administration, Minnesota State Historical Preservation Office, and the Advisory Council on Historic Preservation.

1.7 ACRONYMS AND ABBREVIATIONS

The following acronyms and abbreviations appear in this document. They are defined as indicated:

AAR	Association of American Railroads
AASHTO	American Association of State Highways and Transportation Officials
AC	Alternating Current
ACI	American Concrete Institute
ADA	Americans with Disabilities Act
AHJ	Authority Having Jurisdiction

AISC	American Institute of Steel Construction
AMCA	Air Moving and Conditioning Association, Inc.
ANSI	American National Standard Institute
APS	Auxiliary Power Stations
APTA	American Public Transit Association
AREMA	American Railway Engineering and Maintenance-of-Way Association
ASHRAE	American Society of Heating, Refrigeration and Air Conditioning Engineers
ASME	American Society of Mechanical Engineers
ASTM	American Society for Testing and Materials
AT&T	American Telephone and Telegraph Company
ATP	Automatic Train Protection
ATS	Automatic Train Stop
AW	Assigned Weight used in specifying vehicle performance (i.e. AW0, AW1, etc.)
AWG	American Wire Gauge
AWS	American Welding Society
BICSI	Building Industry Consulting Service International
BIN	Bank Identification Number
BOCA	Building Officials Conference of America
CBD	Central Business District
CC	Central Control
CCC	Central Control Center
CCD	Charge Couple Device
CCER	Central Control Equipment Room
CCITT	Consultative Committee for International Telephone and Telegraphs
CCR	Central Control Room
CCS	Central Control System
CCTV	Closed Circuit Television
CE	Clearance Envelope
CFM	Cubic Feet Per Minute
CFR	Code of Federal Regulations
CRT	Cathode-Ray Tube
CS	Curve-to-Spiral
CT	Construction Tolerance
CTS	Cable Transmission System
CW	Chorded Wall Construction Factor
CWR	Continuous Welded Rail
DB	Dry Bulb
DC	Direct Current
DF	Direct Fixation
DR	Derailment Loads
DWG	Drawing
ECS	Environmental Control System
ECU	Electronic Control Unit
EIA	Electronic Industries Association

EIS	Environmental Impact Statement
EMI	Electromagnetic Interference
ETFE	Ethylene Tetra Fluoroethylene Copolymer
EQ	Earthquake Loads
FACP	Fire Alarm Control Panel
FC	Fare Collection
FCC	Federal Communications Commission
FEA	Finite Elements Analysis
FM	Factory Mutual
FMP	Fire Management Panel
FMP	Fire Management Plan
FRA	Federal Railroad Administration
FRP	Fiber Reinforced Plastic
F.S.	Factor of Safety
FS	Federal Specifications
FTA	Federal Transit Administration
FWB	Fahrenheit Wet Bulb
GFP	Ground Fault Protector
GRS	Galvanized Rigid Steel
HVAC	Heating, Ventilation, and Air Conditioning
ICBO	International Conference of Building Officials
ICEA	Insulated Cable Engineers Association
IEEE	Institute of Electrical and Electronic Engineers
IES	Illuminating Engineering Society
IJ	Insulated Joint
I/O	Input and Output
ISO	International Organization for Standards
LAHT	Low Alloy High Tensile Strength (Steel)
LAN	Local Area Network
LCD	Liquid Crystal Display
LED	Light Emitting Diode
LF	Longitudinal Force
LRT	Light Rail Transit
LRV	Light Rail Vehicle
LVC	Length of Vertical Curve
MAC	Metropolitan Airports Commission
MDBF	Mean Distance Between Failure
MFD	Minneapolis Fire Department
MFE	Mn/DOT Furnished Equipment
MIL	Military Specification
Mn/DOT	Minnesota Department of Transportation
MOW	Maintenance-of-Way
MPD	Minneapolis Police Department
MSBC	Minnesota State Building Code
MT	Maintenance Tolerance
MTP	Magnetic Ticket Processor
MTTR	Mean Time to Repair
MUTCD	Manual of Uniform Traffic Control Devices

NCDC	National Climatic Data Center
NEC	National Electrical Code
NEMA	National Electrical Manufacturer's Association
NESC	National Electrical Safety Code
NETA	National Electrical Testing Association
NFPA	National Fire Protection Association
NSP	Northern States Power
OCS	Overhead Contact System
O&M	Operations and Maintenance
OSHA	Occupational Safety and Health Administration
OSI	Open System Interconnect
OWF	Other Wayside Factors
PA	Public Address
PC	Point of Curvature
PE	Preliminary Engineering
PIN	Personal Identification Number
POP	Proof of Payment
PPM	Parts Per Million
PT	Point of Tangency
PVC	Polyvinyl Chloride
QAP	Quality Assurance Plan
RC	Running Clearance
ROW	Right-of-Way
RPM	Revolutions per Minute
RTU	Remote Terminal Unit
SAP	Substation Alarm Panel
SC	Spiral-to-Curve
SCADA	Supervisory Control and Data Acquisition
SES	Subway Environment Simulation
SMACNA	Sheet Metal and Air Conditioning Contractor's National Association
SONET	Synchronous Optical Network
SPPD	Saint Paul Police Department
SPFD	Saint Paul Fire Department
SQL	Standard Query Language
ST	Spiral-to-Tangent
T	Time
TBM	Tunnel Boring Machine
TES	Traction Electrification System
TOM	Ticket Office Machines
TOR	Top of rail
TPS	Traction Power Station
TPSS	Traction Power SubStation
TS	Tangent-to-Spiral
TVM	Ticket Vending Machine
TWC	Train to Wayside Communication
UBC	Uniform Building Code
UFC	Uniform Fire Code

UL	Underwriters' Laboratories, Inc.
UMC	Uniform Mechanical Code
UMTA	Urban Mass Transit Administration
UPC	Uniform Plumbing Code
UPS	Uninterruptible Power Supply
USDOT	United States Department of Transportation
V	Velocity
VCP	Ventilation Control Panel
VDE	Vehicle Dynamic Envelope
WB	Wet Bulb
WBE	Women's Business Enterprise

1.8 UNITS OF MEASURE

A	ampere
Amp	ampere
BTU	British Thermal Unit
Db	decibel
dbA	decibel on the 'A' weighted scale
Fc	foot-candles
Ft	foot
ft/min	feet per minute
ft ³ /min	cubic feet per minute
G	acceleration due to gravity ($32.2 \text{ ft/s}^2 = 9.81 \text{ m/s}^2$)
Gpm	gallons per minute
H	hour
Hz	Hertz
in.	inch
Kcmil	thousand circular mils
kHz	kilohertz
kWh	kilowatt hour
Lb	pound
Lbs	pounds
Lbf	pound force
mA	milliamperes
mHz	mega Hertz
Mi	mile
Mph	miles per hour
Mphps	miles per hour per second
Min	minute
mV	millivolt
μV	microvolt
Oz	ounce
Pa	Pascal
Pcf	pound per cubic foot
Plf	pound per linear foot
Psf	pound per square foot
Psi	pound force per square inch



S	second
Sec	second
sq ft	square feet
sq yd	square yard
V	Volt
Vac	Volt alternating current
Vdc	Volt direct current
°C	degree Celsius
°F	degree Fahrenheit
'	foot
"	inch
°	degree



2.0 FIRE/ LIFE SAFETY

2.1 INTRODUCTION SCOPE & DEFINITIONS

2.1.1 Purpose

This chapter establishes the Fire/Life Safety design criteria for the Central Corridor Light Rail Transit (CCLRT) Systems for Elevated, At-Grade and Underground conditions. The purpose of this chapter is outlined as follows:

2.1.1.1 Provide sufficient definition and description of safety characteristics to assist design engineers in the determination of appropriate features for systems equipment and facilities. This document is designed to outline those standards and guidelines that, if followed, will assure that the CCLRT achieves the optimal level of fire/life safety.

2.1.1.2 Define the fire/life safety requirements, which shall be included as part of the contract documents.

2.1.2 Passenger Safety Objective

2.1.2.1 Passenger safety shall be accomplished by incorporating design features combined with the development of procedures for the safe and efficient handling of normal, abnormal and emergency conditions.

2.1.2.2 The design of the system shall include provisions to detect and alarm unusual conditions, enabling a timely response and action by emergency response forces. As part of this integrated safety approach, design provisions shall enable safe and timely evacuation of patrons and personnel from structures, disabled vehicles, and facilities. The provisions shall also include necessary safeguards to protect patrons, system personnel, and emergency services during evacuation and shall minimize exposure to hazards created by fire and its related hazards; and unusual or unexpected incidents on the system.

2.1.3 Scope

This chapter outlines the fire/life safety criteria in the following areas:

- Station and site, except Shelter Stops as defined in 1.3.3
- Guideway
- Vehicle
- Signaling
- Communications
- Electrical Power
- Yard and Shop
- Rail Control Center
- Operations
- Training

2.1.3.1 Nothing in this standard is intended to prevent or discourage the use of new methods, materials, or devices, provided that sufficient engineering analysis is

submitted to the authority having jurisdiction to demonstrate that the new method, material, or device is equivalent to or superior to the requirements of this standard with respect to fire/life safety.

2.1.3.2 **Application.** This Criteria applies to new fixed guideway transit systems and to extensions of existing systems.

2.1.3.3 **Definitions**

Alternate Rail Control Center (ARCC). A prearranged location(s) that is equipped, or can quickly be equipped, to function as the Rail Control Center in the event the Rail Control Center is inoperative or untenable for any reason.

Ancillary Area/Ancillary Space. The non-public areas or spaces of the stations usually used to house or contain operating, maintenance, or support equipment and functions.

Approved. Acceptable to the “authority having jurisdiction.”

Areas of Rescue Assistance/Waiting Area - A pre-determined location, which has direct access to an exit, where patrons may temporarily remain in safety to await further instructions or assistance during emergency evacuation. (For determining Occupant Load, calculate at 3 square feet per person).

Authority Having Jurisdiction (AHJ). The organization, office, or individual responsible for approving equipment, an installation, or a procedure. NOTE: Organizations included are building and fire officials, and other departments as applicable.

Automated Fixed Guideway Transit Systems (AGT). A fixed guideway transit system that operates fully automated driverless vehicles along an exclusive right-of-way.

Backlayering. The reversal of movement of smoke and hot gases counter to the direction of the ventilation airflow.

Blue Light Station (BLS). A location along the guideway indicated by a blue light, where emergency services or authorized personnel may communicate with the Rail Control Center.

Central Supervising Station (CSS). The principal manned location in the Rail Control Center where fire alarm, supervisory and trouble signals are displayed, and where personnel are in attendance at all times to supervise the circuits, investigate signals, and immediately retransmit any signal indicative of a fire to the public fire department communication center.

Command Post. The location for controlling and coordinating emergency operations, designated as such by the person in command during an emergency.

Communications. Radio, telephone, and messenger services throughout the system and particularly at the Central Supervising Station.

Computational Fluid Dynamics. A solution of fundamental equations of fluid flow using computer techniques allowing the engineer to identify velocities, pressures, temperatures, and so forth.

Critical Velocity. The minimum steady –state velocity of the ventilation airflow moving toward the fire within the tunnel or passageway that is required to prevent backlayering at the fire site.

Design Fire Scenario. The approved engineering analysis method that considers vehicle combustible load, fire transmission between vehicles, and a sequence of events over time to determine the peak heat release rate from a vehicle fire.

Effective Fire Load. The actual heat release under a given fire scenario expressed in British Thermal Units (Btus) of a certain fuel package, which can include a transit vehicle(s) and/or wayside facilities or structures, that because of the fuel package configuration, separation, and combustion characteristics, would be expected to be released in a design fire incident.

Elevated Structure. All structures not otherwise defined as surface or underground structures.

Emergency Procedures Plan (EPP). A plan developed by the operating authority with the cooperation of all participating agencies detailing specific actions required by all those who will respond during an emergency.

Emergency Trip Switch (ETS). A device by which traction power may be removed from a designated segment of the guideway by authorized personnel.

Engineering Analysis (Fire Hazard/Fire Risk Assessment). An analysis, conducted by qualified personnel approved by the AHJ, and evaluates all various factors that affect the fire safety of the system or component. A written report of the analysis shall be submitted to the FLSC indicating the fire protection method(s) recommended that will provide a level of fire safety commensurate with this standard.

Fire Emergency. The existence of, or threat of, fire and/or the development of smoke or fumes that calls for immediate action to correct or alleviate the condition or situation.

Fire/Life Safety Committee. Designated personnel from the local authorities, and representatives from the transit agency, who are assigned to resolve issues related to Fire/Life Safety. They include Building and Fire Officials, and others as necessary to handle technical and complex designs.

Fixed Guideway Transit System (The System). An electrified transportation system, utilizing a fixed guideway, operating on right-of-way for the mass movement of passengers within the CCLRT metropolitan area and consisting of its fixed guideways, transit vehicles and other rolling stock, power system, buildings, maintenance facilities, stations, transit vehicle yard, and other stationary and movable apparatus, equipment, appurtenances, and structures.

Fixed Guideway Transit Vehicle (The Vehicle or Car). An electrically propelled passenger-carrying rail vehicle characterized by high acceleration and braking rates for frequent starts and stops, and fast passenger loading and unloading.

Guideway. That portion of the transit line included within right-of-way fences, outside lines of curbs or shoulders, underground tunnels, cut or fill slopes, ditches, channels, waterways, and including all appertaining structures.

Heat Release Rate. Energy evolved under a given fire scenario expressed as a function of time.

Incident Commander. The person who is responsible for managing and coordinating all facets of the fire and emergency responses during a fire or other emergency incident. The Incident Commander can be a designated authority staff person or a responsible fire or police representative at the scene.

Incident Command Post. The location during an emergency, selected by the person in command, for controlling and coordinating the emergency operation.

Incidental Occupancies in Stations. Refers to the use of the station by others who are neither transit system employees nor passengers.

Labeled. Equipment or materials to which has been attached a label, symbol or other identifying mark of an organization acceptable to the “authority having jurisdiction”; concerned with product evaluation; maintains periodic inspection of labeled equipment or materials; and by whose labeling the manufacturer indicates compliance with appropriate standards or performance in a specified manner.

Listed. Equipment or materials included in a list published by an organization acceptable to the “authority having jurisdiction” and concerned with product evaluation, that maintains periodic inspection of production of listed equipment or materials and whose listing states either that the equipment or material meets appropriate standards or has been tested and found suitable for use in a specified manner.

NOTE: The means for identifying listed equipment may vary for each organization concerned with product evaluation, some of which do not recognize equipment as listed unless it is also labeled. The “authority having jurisdiction” should utilize the system employed by the listing organization to identify a listed product.

Local Control. The point of control of the emergency ventilation system or ventilation plant that is remote from the RCC.

Noncombustible. A material that, in the form in which it is used and under the conditions anticipated, will not aid combustion or add appreciable heat to an ambient fire. Materials where tested in accordance with ASTM E136, Standard Test Method for Behavior of Materials in a Vertical Tube Furnace at 750 degrees Celsius, and conforming to the criteria contained in Section 7 of the referenced standard shall be considered as noncombustible.

Non-transit Occupancy. Occupancy not under the control of the system operating authority.

Open Station. A station that is constructed in such a manner that it is open to the atmosphere, and smoke and heat are allowed to disperse directly to the atmosphere.

Participating Agency. A public, quasi-public, or private agency that has agreed to cooperate with and assist the operating authority during an emergency.

Person in Command. “See Incident Commander”.

Point of Safety. An enclosed fire exit that leads to a public way or safe location outside the structure, or at-grade point beyond any enclosing structure, or other area that affords adequate protection for passengers.

Power Station. An electric generating plant for supplying electrical energy to the system.

Power Substation. Location of electric equipment that does not generate electricity but receives and converts and or transforms generated energy to usable electric energy.

Rail Control Center (RCC). The operations center where the operating authority controls and coordinates the systemwide movement of passengers and trains from which communication is maintained with supervisory and operating personnel of the operating authority, and with participating agencies when required.

Replace-in-Kind. To furnish with new parts or equipment, as applied to vehicles, systems and facilities of the same type but not necessarily of identical design.

Retrofit. As applied to vehicles and facilities, to furnish with new parts or equipment to constitute a deliberate modification of the original design (as contrasted with an overhaul or replacement-in-kind).

Shelter Stop. A location along the guideway for loading and unloading of passengers that is located in a public way and is designed for unrestricted movement of patrons. A shelter stop may have a cover, but no walls or restricting fences.

Station. A place designated for the purpose of loading and unloading passengers, including patron service areas and ancillary spaces associated with the same structure.

Station Platform. The area of a station used primarily for loading and unloading transit vehicle passengers.

Surface Structure. Any at-grade or unroofed structure other than an elevated or underground structure.

System. See “Fixed Guideway Transit System.”

Tenable Environment. An environment that supports human life for a specific period of time.

Traction Power Substation (TPSS). Location where incoming service it converted to DC power for operation of the transit vehicles.

Trainway. That portion of the guideway in which the transit vehicles operate.

Underground System. The system or that part of the system located beneath the surface of the earth or of the water.

Waiting Area – (See Areas of Rescue Assistance).

2.2 STATION AND SITE

2.2.1 Passenger Stations

Passenger Stations are those facilities and their appurtenances used to load and unload passengers, and are located on exclusive, semi-exclusive, or open right-of-way, often with passenger access restricted by fences or other barriers.

2.2.1.1 Stations shall be designed to facilitate the movement of patrons in an efficient, safe and secure manner.

2.2.1.2 This section is applicable to underground, elevated and at-grade passenger stations.

2.2.1.3 The primary purpose of a station is its use by transit patrons who normally remain in a station structure for a period of time no longer than necessary to wait for and enter a departing transit vehicle, or to exit the station after arriving on an incoming transit vehicle. In its entirety, it essentially functions as a means of accessing and egressing transit vehicles.

2.2.2 Construction Material

2.2.2.1 At-grade or Elevated Construction. Building construction for at-grade or elevated construction for all new transit stations shall be not less than combinations of Type I and Type II approved fire resistive construction as defined in the Minnesota State Building Code (the MSBC).

2.2.2.2 The minimum type of construction for underground stations shall not be less than Type I A or Type I B construction as defined in the MSBC.

2.2.2.3 All structural assemblies and building appurtenances shall conform to the MSBC, as appropriate for the type of construction.

2.2.2.4 Combustible adhesives and sealants may be used when the requirements of Paragraph 2.4.2.1 are met.

2.2.2.5 Interior Finishes - Interior finishes of all surfaces exposed to the interior of the building, including fixed or movable walls and partitions, columns, and ceilings, shall meet the MSBC requirements for interior finishes as follows:

- Interior finishes shall be Class I for all exit access routes and exits. In transit stations, the platforms and mezzanines shall be considered exit access routes for the purpose of determining interior finish requirements.
- Interior finishes in all other areas shall be MSBC Class I or Class II.

2.2.3 Station Occupancy Separations

- 2.2.3.1 Public areas shall be separated from non-public areas by a two-hour fire separation.
- 2.2.3.2 Public areas shall also be separated from, traction power substation, and vaults by a three-hour fire separation if incorporated into the same structure.

2.2.4 Station Mechanical Requirements

- 2.2.4.1 Ancillary area ventilation systems shall be arranged so that air is not exhausted into station public occupancy areas in any ventilation mode. Installation of such systems shall be in accordance with the MSBC.
- 2.2.4.2 Battery storage or similar ancillary rooms, which produce flammable or combustible gases, shall be ventilated in accordance with IFC, and as follows:
 - Interlocks shall be provided to prevent operation of the battery charger when there is no power to the ventilation fan motor or when exhaust air velocity is less than the designed velocity.
 - The no airflow signal shall activate an alarm at the RCC.

2.2.5 Emergency Ventilation

- 2.2.5.1 In enclosed fixed guideway transit stations and tunnels in excess of 1000 feet, ventilation requirements in accordance with NFPA 130 shall be provided for the control of heat and smoke in an emergency, or the removal of toxic or flammable gases in the event of their intrusion into underground facilities/and structures.
- 2.2.5.2 Emergency fans and dampers shall have the following features:
 - Operate in an ambient condition of 250 degrees Celsius for one hour
 - Fans shall be reversible, providing the required capacity in exhaust or supply
 - Fans shall not be protected by thermally activated overload devices
 - Dampers shall be capable of withstanding pressure transients of 70 psf, reversible in direction
- 2.2.5.3 Ventilation Controls
 - 2.2.5.3.1 Fans shall be controlled from the following locations, in descending order of hierarchy.
 - Motor Control Center (MCC)
 - Emergency Management Panel (EMP)
 - Rail Control Center (RCC)

2.2.5.3.2 Status and mode of operation shall be displayed at the EMP, RCC, and MCC.

2.2.5.3.3 Local MCC control shall be protected from the fans by a two-hour separation, with a protected means of access to the MCC.

2.2.5.3.4 Fan operation shall be verified by air flow sensing devices.

2.2.5.3.5 Trouble alarms shall be annunciated at the MCC, EMP, and RCC.

2.2.6 Station Electrical Requirements

2.2.6.1 Electrical equipment, wiring materials, and installation within passenger stations shall conform to the requirements of the MSBC.

2.2.6.2 For underground guideway systems, and where there may be an enclosed at-grade or elevated station, an approved back-up power supply shall be provided for critical Fire/Life Safety systems, and should include but not be limited to:

- Fire detection, alarm and suppression systems
- Emergency lighting
- Emergency telephones
- Elevators Required for Emergency Access/Egress
- Emergency signage to include any automated emergency messages
- CCTV
- Emergency Ventilation
- Fire Pumps

2.2.6.3 Conductors for emergency lighting, communications, and other systems required during emergency operations shall be protected from fires and from physical damage by transit vehicles, and from normal transit system operations and maintenance activities.

2.2.6.4 Adequate electrical grounding shall be provided, where required. Single point grounding may be used for low voltage applications.

2.2.6.5 Controls and outlets in non-environmentally controlled applications shall be installed as per the MSBC.

2.2.6.6 Electrical devices in battery rooms shall be explosion proof in compliance with the MSBC.

2.2.7 Egress/Access

2.2.7.1 Public Occupancy Areas - The transit station shall comply with the provisions of Minnesota State Building Code, except as modified herein. The station public occupancy shall consist of all areas in which patrons may be allowed to enter, and shall include the full length of platforms, mezzanines, corridors, stairways, ramps, and passageways required for emergency egress. Occupancy classification shall be Group A3, as defined in the MSBC.

Public access to station platforms shall be designed in such a way as to encourage or require track crossings and platform access at designated areas and to discourage or prohibit track crossings at other than clearly marked and controlled walkways.

Public access to the platforms in underground and elevated stations shall be by means of vertical circulation elements that provide direct access to the platforms and do not permit track-level crossings.

2.2.7.2 Occupant Load - Exiting for transit stations needs to meet two different criteria. For minimum exits, use the MSBC requirements as defined in Method One. For actual occupant loads and total required exiting use NFPA 130, Method Two. Method One uses standard exiting calculations and may be sufficient for the station. Method Two is more complex and takes into consideration trainloads, peak operating periods, surge factors and entraining loads. These numbers are required to provide sufficient exiting to clear a station before the next train arrives in the station. The MSBC is square footage based, and NFPA 130 is time based. Therefore, sufficient emergency exits are provided by evaluating the design against both methods.

2.2.7.3 For determining occupant load of a station, the following methods shall be used.

2.2.7.4 Method One – Minnesota State Building Code Requirements

2.2.7.4.1 Minimum exiting from all stations shall be provided to accommodate the equivalent of 15 square feet per person. EXCEPTION: Underground or enclosed stations shall use seven square feet per person.

2.2.7.4.2 Where an area within a station is intended for use by other than transit patrons or employees, the occupant load for that area shall be determined in accordance with the provisions of the MSBC.

2.2.7.4.3 At concourses, mezzanines or multi-level stations, simultaneous platform loads shall be considered for all exit lanes passing through that area.

2.2.7.4.4 Travel distance to an exit shall conform to the MSBC requirements in Chapter 10, including allowable increases.

-
- 2.2.7.4.5 For ends of platform where calculated capacity exits emanate within 20 feet from an end of platform, the access points and the exit may be integrated.
- 2.2.7.4.6 Station Ancillary Occupancy Areas - Means of egress shall be arranged in accordance with the MSBC, except that for the purpose of this criterion, exits from station ancillary occupancy areas into station public occupancy areas shall be considered as discharging into an adjoining space leading directly to a point of safety.
- 2.2.7.5 Method Two – National Fire Protection Association Standard 130, 2007 Edition
- 2.2.7.5.1 The occupant load for a transit station shall be based on the emergency condition requiring evacuation of that station to a point of safety. The occupant load shall be based on the calculated trainload of trains simultaneously entering the station on all tracks in normal traffic direction during the peak fifteen (15) minute period plus the simultaneous entraining load awaiting a train and multiplying by the system surge factor of 1 ½ (see Appendix A).
- 2.2.7.5.2 The basis for calculating the platform occupant load shall be the peak hour patronage figures as projected for design of a new transit system, or as updated for an operating system.
- 2.2.7.5.3 Entraining load (on platform awaiting train). The entraining load is equal to the number of passengers that would accumulate on the platform in the time period equivalent to two headways or 12 minutes, whichever is greater, during the peak 15-minute period.
- 2.2.7.5.4 There shall be sufficient means of exit to evacuate the occupant load from the most remote point of station platform(s) in 4 minutes or less.
- 2.2.7.5.5 The station shall also be designed to permit evacuation from the most remote point on the platform to a point of safety in 6 minutes or less.
- 2.2.7.5.6 Platform egress elements shall be stairs, escalators stopped or moving in the direction of egress, emergency stairs, doorways, corridors or walkways to a point of safety.
- 2.2.7.5.7 To calculate evacuation time, the walking travel time should be tabulated using the longest exit route and travel speeds indicated in Paragraph 2.2.7.4.4. In addition to this time, the following factors should be added:
- $(W_1 - T_1)$ The waiting time at the vertical elements at platform level minus the longest walking travel time at platform level.
 - $(W_3 - W_x)$ The waiting time at the vertical or horizontal circulation elements from mezzanine to grade minus the waiting time at the mezzanine vertical circulation elements.
-

- (W₄-W_x) The waiting time, if any, at any additional constriction minus the greatest previous waiting time. (Repeat for all additional constrictions.)

Note: The total of any of the factors above cannot be less than zero.

2.2.7.5.8 Platforms, corridors, and walkways beyond the platform of less than five percent slope: Exit corridors, platforms, and walkways shall be a minimum clear width of three feet eight inches. In computing the width of exiting available, two feet shall be deducted at each platform edge and one foot at each sidewall.

2.2.7.5.9 The capacity in persons per inch per minute (pim), patron travel speeds in feet per minute (fpm), and requirements for exit lanes shall be as follows:

Capacity: 2.08 pim

Travel speed: 124 fpm

2.2.7.5.10 Stairs, stopped escalators, and walkways beyond the platform: Exit stairs shall be a minimum clear width of three feet eight inches. Exit walkways shall be a minimum clear width of six feet. Escalators, either stopped or moving in the direction of egress, may be considered as a means of egress provided they met the requirements of 2.2.7.

Per exit lane : Capacity: 1.41 pim

Travel Speed: 48 fpm*

(* Indicates vertical component of travel speed)

2.2.7.5.11 From each platform there shall be a minimum of two means of egress, each at least 44 inches wide, remote from the major egress route.

2.2.7.5.12 From each mezzanine there shall be a minimum of two means of egress, each at least 44 inches wide. A minimum distance of 40 feet shall separate exits.

2.2.7.6 Special consideration shall be given to stations servicing areas where events occur that establish occupant loads not included in normal passenger loads. These would include such areas as civic centers, sports complexes, convention centers, etc.

2.2.7.6.1 In at-grade or elevated structures so designed that the station platform is open to the elements and, when the concourse is below or protected from the platform by distance or materials as determined by an appropriate engineering analysis, that concourse may be defined as a point of safety.

2.2.7.6.2 Routes from platform ends into the underground guideway shall not be considered as exits for calculating exiting requirements.

-
- 2.2.7.6.3 Escalators may be counted in the egress calculations provided that they are monitored by an approved CCTV system, and that they have the capability of being stopped from a remote location.
 - 2.2.7.6.4 Enclosure of normal patron use stairways and escalators and protection of floor openings are not required within areas of the station public occupancy. EXCEPTION: Stations having more than two levels below-grade or more than 80 feet to the lowest level from grade require protected level separation or other protection features to provide safe egress regardless of exit time calculations.
 - 2.2.7.6.5 All elevators and escalators shall be constructed of non-combustible materials and conform to the MSBC.
 - 2.2.7.6.6 In addition to the exits specified to obtain compliance, a means of egress shall be provided from each guideway to the platform.
 - 2.2.7.6.7 Platform end access gates shall be provided and shall swing towards the platform, and shall provide a clear opening width equal to, or exceeding, the capacity of the stair served, but in no case less than 2 feet 8 inches.
 - 2.2.7.6.8 Vertical circulation elements shall be comprised of stairs or stair/escalator combinations. Escalators shall not account for more than one-half of the required exit width of exit at any one level in the public area. Escalators must be paired in combination with stairs in order to be included in exiting capacity calculations.
 - 2.2.7.6.9 Because of the possibility of maintenance or malfunction, one escalator at each station shall be considered as being out of service in calculating egress requirements. The escalator chosen shall be that one having the most adverse effect upon exiting capacities.

2.2.8 Station Emergency Access

- 2.2.8.1 Designated fire lanes shall be provided to all passenger stations for emergency response and fire department equipment access.
- 2.2.8.2 Fire department inlet connections for automatic sprinkler and standpipe systems shall be located at the primary entrance to the station within 25 feet of vehicular access. Hydrant spacing and locations shall be determined in accordance with local municipal code.
- 2.2.8.3 Stations that are secured during non-revenue hours and/or have locked ancillary spaces shall have a key lock box system located at the primary station entrance or as determined by the Authority Having Jurisdiction. Keys shall provide access to all parts of the station.

2.2.9 Emergency Lighting and Signing

- 2.2.9.1 All enclosed passenger stations shall have lighting of not less than one foot-candle at the walking surface along evacuation routes.
- 2.2.9.2 Emergency lighting shall be designed, installed and maintained in accordance with NFPA 70- National Electrical Code, Emergency Systems.
- 2.2.9.3 Emergency exits signs shall be provided in accordance with the MSBC.
- 2.2.9.4 Emergency lighting shall be designed to highlight the top and bottom of stairs and escalators in addition to the required emergency illumination.
- 2.2.9.5 In compliance with Minnesota Accessibility Code, stations shall provide both visual and audible announcements when a situation requires emergency action or station evacuation.
- 2.2.9.6 Enclosed emergency stairwell signage shall be provided at each floor landing and identify the level and exit direction, and shall be visible from within the stairwell and when the door is in the open or closed position. Signs shall be approximately five feet above the floor. The colors shall be as approved by the Authority Having Jurisdiction.
- 2.2.9.7 Tunnel emergency lighting shall conform to NFPA 130, Section 6.2.5.

2.2.10 Fire Protection - Stations

Fire protection installations shall conform to the MSBC.

2.2.11 Fire Suppression Systems

- 2.2.11.1 Train control and communication rooms, if contained within passenger stations shall be protected either with pre-action sprinkler system or an environmentally acceptable fire extinguishing system.
- 2.2.11.2 The design shall permit activation automatically and manually from inside the room. A manual activation device shall be installed outside the room.
- 2.2.11.3 The room ventilation system shall be shut down and dampers closed prior to discharge of the extinguishing agent.
- 2.2.11.4 Automatic activation shall be through a cross-zoned detection system.
- 2.2.11.5 Automatic sprinkler protection designed and installed in accordance with NFPA 13 and the MSBC shall be provided as required by the AHJ.
- 2.2.11.6 Water flow and trouble alarms shall be annunciated at RCC and the station emergency management panel (EMP).

2.2.12 Water Supply and Fire Hydrants

2.2.12.1 Water flow and fire hydrant requirements for all areas of passenger stations shall be in accordance with the MSBC and local municipal codes.

2.2.13 Standpipes: At-Grade and Elevated Stations

2.2.13.1 Station locations with limited access shall have a dry standpipe system, conforming to the MSBC and NFPA 14.

2.2.13.2 Any at-grade station that has been integrated into commercial facilities shall be protected by a Dry Standpipe System (DSP) conforming to the MSBC.

2.2.13.3 Standpipes shall be arranged to comply with the AHJ requirements.

2.2.14 Standpipes: Underground Stations

2.2.14.1 Underground stations shall be provided with a Class I Dry SP in accordance with NFPA 14 and the MSBC.

2.2.14.2 The station DSP shall be fed from fire protection valve pits (FPVP), located in an area protected from the environment. Each FPVP shall be:

- Supplied from water mains which are at least eight inches in diameter
- Connected to the tunnel standpipes
- Provided with four-way inlet connections
- Provided with graphics describing the operation and area covered.
- Located in an area not subject to vehicular traffic but within 300 feet of a hydrant
- Valves have tamper switches on them
- Valves shall be equipped to operate remotely from RCC, the EMP and from other locations as requested by the AHJ.

2.2.14.3 The standpipe system shall be cross-connected in stations, so that the station DSP can be supplied from either fire protection valve pit (FPVP).

2.2.14.4 Water flow shall be annunciated at the RCC, EMP and the MAC RCC.

2.2.15 Portable Fire Extinguishers

Multipurpose fire extinguishers shall be located in passenger station ancillary spaces, in accordance with IFC.

2.3 GUIDEWAY

The guideway shall be designed in such a way as to discourage or prohibit public crossing other than at marked, controlled crossings. Fencing, landscaping and other right-of-way elements shall be considered to ensure the public is directed to appropriate guideway crossings.

Passengers shall only evacuate a train when required by conditions, and then only under the guidance and control of authorized and trained transit personnel or other authorized personnel (fire personnel, police).

2.3.1 Flammable and Combustible Liquids Intrusion

To protect the system from accidental intrusion of flammable or combustible liquids due to spills, follow NFPA 130, Section 6.6.

2.3.2 Construction

Guideway construction shall meet NFPA 130, Chapter 6 requirements.

2.3.3 Access

- 2.3.3.1 Access to the guideway by emergency response personnel shall be through passenger stations or directly from crossing or parallel public streets. Emergency response personnel may also use emergency stairs where applicable.
- 2.3.3.2 Where provisions of 2.3.3.1 cannot be met for access to the elevated guideway, roads shall be provided at maximum intervals of 2,500 feet.
- 2.3.3.3 Access gates shall be provided in security fences as determined by CCLRT and the AHJ.
- 2.3.3.4 Where a roadway is provided to a fenced, at-grade guideway, gates shall have a minimum unobstructed opening of 20 feet. Personnel gates shall be at least 48 inches wide.
- 2.3.3.5 Gates shall be located as close as practicable to portals for ease of access to tunnels.
- 2.3.3.6 The maintenance access shall be designed and constructed for use by emergency vehicles, if more than 150 feet from a public roadway.
- 2.3.3.7 Graphics shall be provided adjacent to each gate identifying the track section, geographic location, and traction power feeder zone. Warning signs, identifying the appropriate hazards, shall be posted at access points to the guideway, at fences and barriers.

2.3.4 Means of Egress

2.3.4.1 Emergency egress from transit vehicles in tunnels and through tunnels to a point of safety shall be provided.

2.3.4.2 A point of safety shall meet the following requirements:

- Tunnels separated by a minimum 2-hour rated fire barrier at each tunnel, with openings at each end of cross passages protected by Class B (1 ½ hour) fire assemblies, or a common three-hour rated wall between adjacent tunnels with openings protected with Class A (3-hour) fire assemblies
- Blue Light Station(s) shall be available at each point of access to enclosed points of safety
- Egress from and access to this area shall not require returning through the tunnel of fire origin
- Emergency lighting shall be provided

2.3.4.3 In addition to the requirements specified in Paragraph 2.2.7, provide the following features necessary for effective emergency egress of patrons from disabled transit vehicles:

- A safety walk on one side of the tunnels, placed at the height of the vehicle floor (plus zero inches, minus seven inches) to facilitate egress through vehicle side doors.
- Level walkways, including ramps having a slope not exceeding four percent, shall have a clear width not less than 30", a maximum cross slope toward the trackway of 0.5 percent and continuous wall handrails mounted, 34" to 38" above the walkway with 1 ½ inch minimum space between the handrail and the wall. No protrusions into the walkway shall extend further than a perpendicular line tangent to the handrail.
- Stairs and ramps having a slope in excess of four percent shall have a clear width of 2' 10" and be equipped with 3' 6" high guardrail having an intermediate rail at mid-height. Cross slope shall be as required for level walkways. Stairs shall have a minimum of two risers, and shall be constructed in accordance with the MSBC.
- A clear vertical envelope shall be maintained on the walkway of 6' 6" at the walking surface, two from 5' to 5' 6", and one 6" at 6' 8" with a worst-case static vehicle envelope.

2.3.4.4 Track walkways, when utilized for emergency egress, shall have a uniform level walking surface, not less than thirty inches (30") wide provided between the tracks. The surface shall be flat and free from obstructions, holes, and drainage channels for the required width.

-
- 2.3.4.5 Crosswalks shall be provided at track level to assure walkway continuity where safety walks are discontinued on one side of the tunnel and continued on the opposite side and where access is required from safety walks and track walkways to emergency stairs or cross passages. The crosswalks shall have a uniform, level walking surface at top of rail, with a minimum width of 44 inches. The crosswalk surface shall be sloped a maximum of four percent from track walkway elevation.
- 2.3.4.6 Walkway continuity shall be maintained at special track sections. Crosswalks shall be provided the full width of all trackways at both ends of special track sections. Safety walks of both trackways shall be located alongside the exterior walls. They shall have a clear width of two feet four inches, guard rails, and use a maximum of four percent slope ramps for elevation changes, or both trackways shall be provided with a walkway top-of-rail height of a minimum of three feet eight inches from crosswalk to crosswalk.
- 2.3.4.7 Emergency Exits to the Surface - The emergency exits provide a capability for patron egress and access by emergency personnel. They consist of fire-resistive enclosed stairways and passageways supplementary to access for underground trainways at stations and portals, and are required as follows:
- Emergency exits to the surface shall be provided at intervals not exceeding 1250' when trackways are not separated by solid walls or when the trackways are not accessible from each other due to individual tunnel profiles.
 - Where trackways are separated from each other by solid walls with the required fire resistance and having cross passages meeting the requirements of 2.2.7, emergency exits to the surface shall be provided at unprotected openings in the separating wall away from stations, such as special track locations.
 - Emergency exit enclosures shall be separate from ventilation shafts, although they may be adjacent. Stairs and passageways shall have a minimum clear width of three feet eight inches and shall be constructed per the MSBC requirements.
- 2.3.4.8 Emergency exit discharge shall be to a point of safety through an opening with a minimum width of 3' 8" and a minimum height of 6' 8". The exit will comply with the following:
- Vertical exit door in a surface kiosk or an adjacent building meeting the MSBC requirements for Class A Occupancy. Entrance from the outside shall be provided as approved by the AHJ.
 - Exit doors at the surface shall be provided in areas not subject to vehicular traffic.
 - Emergency exit facilities shall be suitably identified and maintained to allow for their intended use.

2.3.4.9 Cross passages - Distance between tunnel cross passages shall be approved by the FLSC. Cross passage spacing shall be 750 feet nominally, and shall not exceed 800 feet, unless authorized by the FLSC. They shall meet the following requirements:

- The sill of a cross passage opening shall match the elevation of the service walkway or crosswalk to which it connects. The cross passage shall have a minimum clear, unobstructed width of six feet six inches, and it shall have a desirable height of eight feet and a minimum height of seven feet.
- Cross passages may be incorporated in pump or ventilation structures. The passageway shall be separated from the air plenums and sumps and be enclosed by construction with a minimum fire rating of two hours. Space for any ventilation or drainage equipment shall be provided exclusive of the six feet six inches required in Paragraph 2.3.4.9 above.
- The minimum dimensions of the door opening shall be 3'0" wide by 6' 8" high.
- Doors, door frames, and hardware shall have a minimum fire rating of one and a half hours (Class B).
- Doors shall be equipped with door closures and passage latch sets to allow opening from either side. All doors, door frames, and hardware shall be designed to withstand an air pressure of 70 pounds per square foot (psf) applied on either side of the entire door area.

-
- 2.3.4.10 Emergency Exit Doors. Emergency exit doors shall be provided at maximum 500 foot intervals in the common wall separating the trainways in cut-and-cover structures. A single sliding door shall be used with the door and hardware having a minimum fire rating of three hours (Class A). The door shall be self-closing and equipped with pull handles to allow opening from either side.
 - 2.3.4.11 Identification of Exits. Cross-passage and exit doors shall be identified by signs and lights.
 - 2.3.4.12 Egress for Passengers. The system shall incorporate means for passengers to evacuate a train at any point along the guideway and reach a safe area. System egress paths shall be illuminated.
 - 2.3.4.13 For surface and aerial structures a minimum 2' 6" clear, unobstructed walkway shall extend along the guideway outside each track, or a center walkway may serve both tracks. Center walkways shall have a minimum clear width of 2' 6", but in no case shall appurtenances (centenary poles, light standards, etc.) reduce walkway width or cause obstructions. Walkways designated for evacuation of passengers shall be constructed of non-combustible materials. Walkway surfaces shall have a slip-resistant design. Open grating surfaces shall not be permitted. Ballasted walkways shall be tamped to maintain a level surface.

2.3.5 Emergency Lighting

- 2.3.5.1 Tunnel emergency lighting illumination levels of a minimum one foot-candle shall be provided at the surface of walkways, stairs, crosswalks, cross passages, and all other components of emergency exits.
- 2.3.5.2 Tunnel lighting power supply shall be from separate sources so that loss of power from one source will not remove power from the tunnel lighting.

2.3.6 Fire Protection – Tunnels

- 2.3.6.1 Standpipe and Hose System - A Class I dry standpipe system shall be installed, to provide protection throughout the underground guideway system, in accordance with the MSBC.
- 2.3.6.2 The standpipe system for underground locations shall be supplied through direct connections from the public water supplies at station locations, portals, and other access points to the system. Station standpipe supplies and guideway standpipe supplies may be combined
- 2.3.6.3 Where water supplies divide to feed standpipe systems in two directions, check valves shall be provided at the point of connection to each feed main. When needed for required system reliability, a normally closed bypass may be employed.

-
- 2.3.6.4 Fire department inlet connections shall be provided at each point of connection to public supplies.
- 2.3.6.5 The inlet connection shall be arranged to join the public main supply at street level utilizing the standard valve pit arrangement of the MSBC, including control valves and check valves.
- 2.3.6.6 Inlet connections shall be visible from a public way.
- 2.3.6.7 Graphics identifying the portions of the trainway supplied shall be placed at each surface fire department inlet connection location. Graphics, text, and size of lettering shall be approved by the AHJ.
- 2.3.6.8 Control valves and check valves at points of system supply and subdivision shall only be located at stations, portals, street level valve pits, and within cross passages and exit enclosures.
- 2.3.6.9 The guideway standpipe shall be hydraulically designed to provide a minimum of 250 gallons per minute at a residual pressure of 100 pounds per square inch to each of the two adjacent, most hydraulically remote standpipe outlets.
- 2.3.6.10 Fire hose outlets shall be equipped with 2½” inch valves with 2½” inch NST fire hose thread, with cap and chain, and be positioned as follows:
- Outlets shall be provided inside of cross passages and enclosures of each emergency exit to the surface. Valves shall not prevent the doors from opening when a hose line is installed.
 - Outlets shall also be installed in each guideway with locations coordinated with cross passages and exit enclosures to obtain spacing not exceeding 250 feet between hose outlets.
 - In cut-and-cover subway structures, hose outlets shall be provided on each side of the separating common wall, near each exit door and at intervals not to exceed 250 feet.
 - Identifying graphics shall be affixed to tunnel walls at each hose outlet valve, or painted directly on the standpipe in white letters.

-
- 2.3.6.11 All common supply piping shall be sized for a minimum flow of 500 GPM for the first standpipe plus 250 GPM for each additional standpipe, the total not to exceed 2500 GPM.
 - 2.3.6.12 Standpipe system control valves shall be supervised from the fire alarm control panel in an adjacent station by means of valve-position indicators. One valve-position indicator shall be provided for each valve. One indicator signal (series wired indication circuit) from valves within each fire-rated enclosure is permitted.
 - 2.3.6.13 DSP Valves shall be capable of being opened remotely from RCC and the EMP.

2.3.7 Tunnels Under Construction

- 2.3.7.1 A standpipe system, either temporary or permanent in nature, shall be installed in tunnels under construction, before the tunnel has exceeded a length of 200 ft. beyond any access shaft, and shall be extended as tunnel work progresses.
- 2.3.7.2 Temporary standpipes, which may be used by contractors to furnish water for construction purposes, shall be sized to flow a minimum of 250 gallons and be equipped with hose outlets and valves with 2 ½ inch hose thread conforming to IFC, and may have suitable reducers or adapters attached for connection of contractor's hose. Such reducers or adapters shall be readily removable by use of fire fighter's hose spanner wrenches.

2.3.7.3 Permanent standpipes or temporary standpipes installed in tunnels during construction shall be provided with risers to the ground surface level. Such risers shall be equipped with approved fire department connections, which shall be identified with appropriate signs and shall be readily accessible for fire department use, and protected from accidental damage. There shall be a check valve and ball drip or drain in the riser near the connection to the standpipe.

2.3.7.4 Permanent or temporary standpipes, installed during the construction phase, shall be supported and shall be of sufficient strength to withstand the pressure and thrust forces to which they may be subjected.

2.3.7.5 Temporary standpipes shall remain in service until the permanent standpipe installation is complete.

2.3.8 Permanent standpipes

Permanent standpipes shall conform to the MSBC.

2.3.9 Wayside traction power substations

Wayside traction power substations, and rooms and structures housing train signaling or incoming electrical service equipment which is connected to the stations or tunnels shall be equipped with an automatic fire detection system, and/or an automatic fire suppression system.

2.3.10 Status of detection and suppression systems

The status of all detection and suppression systems shall be monitored and displayed at the RCC.

2.3.11 Protection of signaling or communications equipment

Rooms or structures housing signaling or communications equipment shall be protected with an automatic fire suppression system.

2.3.12 Portable fire extinguishers

Portable fire extinguishers shall be provided in accordance with IFC.

2.3.13 Substations

2.3.13.1 Traction power substations shall be independently ventilated per the MSBC.

2.3.13.2 All electrical equipment and wiring in traction power substations shall conform to the requirements of NFPA 130, 6.4 Traction Power.

2.4 LIGHT RAIL VEHICLE (LRV)

This section defines the requirements of Fire/Life Safety for the Light Rail Vehicle.

2.4.1 General

All new passenger carrying fixed guideway transit vehicles shall be, at a minimum, designed and constructed to the requirements of NFPA 130 Chapter 8, Vehicles.

- 2.4.1.1 The design shall locate equipment outside of the passenger compartment, whenever practicable, and isolate potential ignition sources from combustible materials.
- 2.4.1.2 The LRV end caps, roof and floor shall be designed to prevent propagation of a fire to the vehicle interior.
- 2.4.1.3 Fire stops shall be provided at floor and roof penetrations. In the design of the roof, consideration shall be given to prevention of arc penetration and susceptibility to ignition of materials in the roof or equipment mounted on it.

2.4.2 Combustible Content

The design of the LRV shall place major emphasis upon minimizing the total combustible content of the vehicle and the heat release rate.

- 2.4.2.1 Total combustible content of each LRV shall be no greater than 90 million BTU's, with a heat release rate not to exceed 45 million BTU's/hour and shall be verified by engineering analysis (i.e., testing, modeling, calculations, etc).

2.4.3 Flammability, Smoke Emission and Toxicity of Light Rail Vehicle (LRV) Materials

- 2.4.3.1 Materials used in LRV shall be tested by a nationally certified testing facility to demonstrate compliance with the requirements set forth in NFPA 130, Chapter 8 and Table 8.4.1.
- 2.4.3.2 Previously performed and certified tests for the same type of vehicle being used by the transit district may be submitted for consideration by the AHJ.
- 2.4.3.3 Materials and products generally that are recognized to have products of combustion that are highly toxic shall not be used.
- 2.4.3.4 The LRV floor shall be subjected to a fire exposure test in accordance with NFPA 130 and ASTM 119E for a minimum duration of 30 minutes.
- 2.4.3.5 The LRV roof shall be subjected to a fire exposure test in accordance with NFPA 130 and ASTM 119E for a minimum duration of 15 minutes.
- 2.4.3.6 Provision shall be made for a fire/heat load test and/or analysis on roof mounted equipment to ensure structural integrity of the roof.

2.4.4 Portable Fire Extinguishers.

Each vehicle or cab shall be equipped with an approved multipurpose portable fire extinguisher of the 10-lb. class, rated 4A40-B:C.

2.4.5 Electrical Requirements

Electrical requirements shall be consistent with NFPA 130, Section 5.

2.4.5.1 All motors, motor controls, current collectors, and auxiliaries shall be of a type and construction suitable for use on the LRVs.

2.4.5.2 Self-ventilated resistors shall be mounted with air space between resistor elements and combustible materials; and heat-resistant barriers shall extend horizontally beyond resistor supports for protection from overheated resistors.

2.4.5.3 Emergency lighting and other designated emergency electrical equipment shall be capable of functioning for a minimum of one hour, following loss of external power. Emergency lighting shall be provided throughout each passenger vehicle. The minimum illumination level, measured at the floor, shall be one foot-candle.

2.4.6 Doors and Emergency Exiting

2.4.6.1 Side doors shall be designed to be opened by patrons under emergency conditions, including the loss of electrical power.

2.4.6.2 At least one door on each side will be capable of being opened by emergency response personnel from outside the vehicle, both manually and electrically.

2.5 SIGNALING

2.5.1 Signaling blocks shall coincide with emergency ventilation

The signaling blocks shall coincide with the location of emergency ventilation, where provided, to prevent an incorrect fan mode of operation being initiated.

2.5.2 Signal blocks and ventilation zone

Signal blocks shall prevent two trains from occupying the same ventilation zone at the same time.

2.6 COMMUNICATIONS

2.6.1 General

This section defines the Fire/Life safety requirements for communications systems.

- 2.6.1.1 Dependable, flexible and redundant communication networks shall be provided for continuous contact with required personnel and patrons as follows:
- 2.6.1.2 The communications systems must operate in both normal and emergency modes; these must be developed to provide emergency voice communication capability, and to provide data to operating and emergency response personnel during an emergency.
- 2.6.1.3 Emergency voice communications shall be provided by the same systems used for normal operations. Table 1-1 indicates the points between which emergency voice communications capability shall be provided. The additional requirements that must be met by these subsystems in order to fulfill Fire/Life safety functions are contained in the following paragraphs.

2.6.2 Transit Radio Subsystems

- 2.6.2.1 The transit radio subsystem shall provide at least one dedicated two-way voice communications group for use in emergency situations. The emergency channel shall have the capability of communicating with transit system personnel on trains, in motor vehicles, and at all locations within the system.
- 2.6.2.2 Two-way radio voice communication capability for non-transit system emergency response personnel shall be provided by their own equipment. Communications shall be provided in tunnels by integrating a non-transit channel with antenna.

Table 1-1, Emergency Voice Communications Matrix

	R.C.C	Vehicle Operator	Patrons on Trains	Patrons in Stations	Emergency Response Organization	On-duty Transit Personnel
Patrons on Trains		X				
Patrons in Stations	X					
Vehicle Operator	X		X			
Rail Control Center		X		X	X	X
On-duty Transit Personnel	X	X		X	X	X
Emergency Response Personnel	X				X	X

NOTE: Detailed data from the automatic fire detection, alarm, and control systems and from intrusion detectors shall be provided locally in such a manner as to allow emergency response personnel to formulate proper responses.

2.6.3 Emergency Telephone Subsystem (ETEL)

2.6.3.1 ETELS shall be provided for use by the public, employees, and emergency response personnel.

2.6.3.2 ETELS shall be located to provide communication capability between the RCC and passenger stations, traction power substations, elevators, yard and maintenance facilities, emergency exit routes, access points along the guideway, and emergency trip station locations.

2.6.3.3 There shall be one or more ETEL in every yard and maintenance facility structure, located to limit travel distance to an instrument, (except for small structures having at least one emergency telephone within 100 feet). At a minimum, ETEL shall be located at each emergency trip station. These telephones shall terminate at the RCC.

2.6.3.4 Additional ETEL'S may be required at ancillary spaces, offices, and other structures.

2.6.3.5 The Emergency Telephone Subsystem shall be designed to:

- Substitute for the required manual pull station
- Conform to the guidelines for "911 type" systems in NFPA 1221
- Be located no more than 200 feet from any point to an exit
- Annunciate at RCC identifying the station, and for guideway installations, the location
- In underground stations, be co-located in the public areas with a fire cabinet containing a fire extinguisher

2.6.4 Public Address (PA) Subsystem

2.6.4.1 Underground, and enclosed at-grade and elevated stations, and major maintenance facilities shall have public address subsystems to allow communications under normal, abnormal and emergency conditions with patrons or employees, as appropriate.

2.6.4.2 The public address system shall be zoned by building. Small separated buildings may be included in the zone of a nearby principal building.

2.6.4.3 The public address subsystem shall conform to the requirements of NFPA 72 for emergency voice communication systems.

2.6.4.4 The RCC shall have the capability of using the public address subsystem to make announcements. Override access to the passenger station or maintenance facilities PA subsystems shall be provided at emergency management panels associated with the specific facility.

2.6.4.5 Visual “reader boards” or “message boards” shall be used to provide necessary information to the hearing impaired during an emergency in locations as approved by the AHJ.

2.6.5 Emergency Management Panel (EMP)

2.6.5.1 An EMP shall be provided at passenger stations having escalators, elevators, fire protection systems, and/or emergency ventilation.

2.6.5.2 EMP’s shall be located next to the primary entrance as approved by the AHJ.

2.6.5.3 The EMP shall incorporate the following provisions:

- Access to the emergency telephone (ETEL)
- Preemption capability for the public address subsystem
- Distinctive signage and/or lighting for identification
- Annunciation for station alarms and water flow signals

2.6.5.4 The EMP shall have the following provisions on a site-specific basis:

- FACP subsystem status indicators
- Escalator, elevator, and ventilation control
- Indicators showing where the fans are being controlled: RCC, EMP or Motor Control Centers (MCC)
- Tamper alarm at a fire protection valve pit
- Graphics showing the station layouts and zone(s) in alarm and type of alarm

2.6.6 Fire Alarm Control Panel (FACP) Subsystem

The FACP subsystem shall perform the following functions, in accordance with NFPA and UL:

- Automatic fire detection, alarm, and supervision
- Automatic fire suppression equipment actuation and supervision
- Emergency voice communications subsystems status supervision, and control
- Control and supervision of the status of various mechanical and electrical systems and equipment, as necessary for proper response to emergencies
- Control and supervision of the FACP subsystem shall be at the RCC and shall meet the requirements of NFPA 72 for Central Station Service

2.6.7 Blue Light Station (BLS)

A Blue Light Station is defined as a location within the right-of-way, with the following features:

- Identified by a blue light
- Equipped with an emergency telephone, with automatic location identification. Provide handheld telephone units in tunnels.
- At TPSS and other approved locations, the BLS shall have an ETS installed
- BLS shall be provided at tunnel cross passages

2.7 ELECTRICAL POWER

This section defines the Fire/Life safety requirements for consideration in the design of electrical power, traction power and traction power substations.

2.7.1 Electrical Requirements

2.7.1.1 The installation of electrical wiring for structure light and power, and the installation of all electrical devices not supplying traction power within all maintenance facilities, shall be in accordance with the MSBC.

2.7.1.2 Overhead catenary systems shall meet the following requirement:

- Minimum overhead clearance for at-grade systems shall be 15 feet unless required to be reduced due to a permanent overhead obstruction ex: skyway. In that event the height of the overhead catenary system shall be reviewed and discussed by Metro Transit and applicable AHJ's prior to approval and incorporation into the design documents.
- Emergency power shut-off devices (ETS) shall be provided in accordance with requirements of the AHJ

2.7.2 Electrical Substations

2.7.2.1 Two means of emergency exiting for maintenance facilities shall be provided in accordance with the MSBC and NFPA130.

2.7.2.2 Emergency lighting shall be provided for all exits within the maintenance facilities and substations in accordance with the MSBC and NFPA130.

2.7.3 Emergency Trip Stations (ETS)

ETS's shall be co-located with a BLS at TPSS, and other approved locations and shall have the following:

- The ETS shall remove power throughout the designated OCS section on the affected track
- Annunciate at RCC

-
- An ETS shall be located at an approved location of underground and elevated stations, and at other locations deemed necessary by the AHJ
 - RCC shall have the capability to selectively restore traction power to any guideway segment(s) in the power zone in which the emergency trip station has been activated.

2.8 YARDS AND SHOPS

This section defines the Fire/Life safety requirements for the design of yard and shops. Applicable MSBC, NFPA 130, and local building codes shall be incorporated into the design of maintenance facilities.

2.8.1 Maintenance Facilities

2.8.1.1 Maintenance facilities shall be classified in accordance with the MSBC.

2.8.1.2 Road access and fire suppression shall be provided for all facilities.

2.8.2 Fire Protection

2.8.2.1 Protective Signaling Systems. An automatic fire detection, alarm, and control system, conforming to the requirements of NFPA 72, shall be installed at the yard and maintenance facilities site. Water flow alarm and control valve supervision shall be provided for automatic sprinkler systems. A fire alarm annunciator panel shall be provided near the point of primary access to each principal building or building group.

2.8.2.2 Automatic Sprinklers. Approved, automatic sprinkler systems shall be installed in all areas of maintenance facility structures except electrical distribution rooms, signaling rooms, and traction power substations. The sprinkler systems shall be hydraulically designed and installed in accordance with NFPA 13, the MSBC, and local municipal codes.

2.8.2.3 Other Fire Suppression Systems. Electronic equipment rooms containing essential communications and signaling equipment shall be provided with an approved fire suppression system.

2.8.2.4 Portable Fire Extinguishers. Portable fire extinguishers shall be installed per IFC.

2.8.3 Yards

An approved water Supply and Distribution system shall be installed per IFC

2.8.4 Emergency Access

- 2.8.4.1 Emergency access shall be provided to facilities within the yards and shops area through public streets or transit access roads per the IFC.
- 2.8.4.2 The yard and shop shall be protected with security fencing and have access gates located as required by the AHJ.
- 2.8.4.3 In storage areas, yard tracks shall allow a minimum clearance of 3' between the sides of adjacent transit vehicles and a minimum unobstructed access of 7' on one side of the vehicle.

2.8.5 Mechanical Systems

- 2.8.5.1 In pit areas where under-car maintenance may generate fumes of a combustible nature (blow-downs facilities for transit vehicles), a positive mechanical exhaust ventilation system shall be provided. The ventilation system shall be capable of air changes at the rate of 10 per hour or 1 cfm/ft² of pit floor area, whichever is greater, during normal operation. The system shall be designed to discharge to the outside. Maintenance pit areas shall meet the requirements of NFPA 130, and the MSBC.
- 2.8.5.2 Mechanical ventilation systems shall be installed in accordance with the MSBC. Blower and exhaust systems for vapor removal shall be installed. Electrical power and airflow interlocks shall be provided in accordance with NFPA 130.

2.9 RAIL CONTROL CENTER (RCC)

This section defines the Fire/Life Safety requirements for the design of RCC. The RCC shall be the central point for coordinating all train operations, station operations and for communicating directly with train operators, maintenance, supervisory, emergency personnel, and patrons (as required). The following capabilities shall be incorporated into the design of the RCC.

2.9.1 Rail Control Center Facility

- 2.9.1.1 The RCC shall be a controlled space for housing electronic equipment, personnel, and supporting facilities to be used for operation and supervision of the transit system through signaling, communications, and fire and security management.
- 2.9.1.2 The RCC shall be arranged and equipped to function as the central supervising station for the entire system, in accordance with NFPA 72.
- 2.9.1.3 During normal operations, the RCC shall provide primary control of transit operations. For emergencies, emergency response personnel shall be responsible for control, supervision and coordination of emergency activities.

2.9.1.4 The RCC shall retain responsibility for operation of unaffected parts of the system.

2.9.1.5 The Rail Control Center shall be equipped to:

- Receive, log, printout, and annunciate fire, security, and supervisory alarms
- Receive, record, and log emergency telephone messages, including designation of the origin of the call
- Communicate with passenger vehicle operators and other on duty transit personnel
- Use the public address subsystem
- Prepare passenger stations for evacuation, if necessary
- Selectively remove and restore traction power
- Have direct line telephone communication with the dispatch facilities of appropriate emergency response jurisdictions
- Monitor appropriate emergency response organization's radio channels
- Monitor and control signals, track switches, emergency ventilation fans and pumps
- Monitor and control elevators and escalators, (if used)

2.9.1.6 An area for coordinating fire department operations shall be provided at the RCC. This area shall have access to the following:

- Public address system display
- Direct line to appropriate fire department dispatch centers
- Emergency Telephone Subsystem
- Fire detection, sprinkler valve, and water flow annunciator displays
- Standby power status indicators
- Ventilation and air handling status indicators
- Monitoring of selected fire department radio channels

2.9.2 Construction

2.9.2.1 The RCC facilities shall comply with the MSBC, Type I or Type II construction requirements. All structural assemblies and building appurtenances in the RCC shall be of noncombustible material.

2.9.2.2 The RCC shall provide and maintain occupancy separations as required by the MSBC, and as follows:

- The RCC, including ancillary rooms, shall be separated from uncontrolled public access areas and any other occupancy by minimum two-hour fire rated construction, with the openings protected by labeled 1-1/2 hour fire rated (Class B) door assemblies.
- The RCC data processing and control areas shall be separated from all ancillary rooms by minimum 1-hour fire rated separations, with the openings protected by labeled 1-hour fire rated door assemblies.
- Ancillary areas within the RCC shall comply with the separation and protection requirements. Cabling from the RCC to system operating areas, and to all other services essential to the operation of the RCC, shall be routed separately from other building services.
- Fire rated door assemblies protecting openings in fire rated separations shall be automatic or self-closing and shall be installed in accordance with the MSBC.

2.9.3 Interior Finishes

Interior finishes shall meet the MSBC Class I or II requirements. Interior finished shall be Class I for all exits and exit access routes, and for the RCC area. In all other areas, interior finishes shall be Class I or II.

2.9.4 Access and Egress

2.9.4.1 Access to the RCC building shall meet the requirements of the MSBC.

2.9.4.2 Egress routes serving the RCC and other occupancies shall be two-hour fire-rated enclosures, with self closing and latching, Class B, 1-1/2 hour rated doors.

2.9.4.3 The RCC shall have at least one dedicated access/egress element.

2.9.5 Emergency Lighting

Emergency lighting shall be provided for all egress routes from and throughout the entire RCC area, per the MSBC.

2.9.6 Fire Protection

2.9.6.1 Water supplies and hydrants for the RCC shall conform to the MSBC. Standpipe and automatic sprinkler water supplies shall meet the requirements of NFPA 14 and 13, in addition to the MSBC.

2.9.6.2 Standpipes, as required by NFPA 130 and the MSBC shall be installed in the RCC.

-
- 2.9.6.3 Automatic sprinkler protection shall be provided throughout the entire RCC building and shall be hydraulically calculated, designed, and installed in accordance with NFPA 13 and the MSBC.
 - 2.9.6.4 An approved fire suppression system shall be provided for in areas in the RCC building containing critical communications and train signaling equipment, and for tape storage rooms. Consoles and under-floor spaces shall be protected.
 - 2.9.6.5 Portable fire extinguishers conforming to IFC shall be installed throughout the RCC building.

2.9.7 Protective Signaling System

- 2.9.7.1 An automatic fire detection, alarm, and control system, complying with the requirements of the MSBC shall be provided throughout the RCC building.
- 2.9.7.2 A public address subsystem shall be provided at the RCC.
- 2.9.7.3 Smoke detectors shall be installed throughout all areas of the RCC that are protected by specialized fire suppression systems, (normally unoccupied areas such as electrical rooms).
- 2.9.7.4 Automatic sprinkler systems shall be provided with water flow alarm and control valve supervision for annunciation at the RCC.
- 2.9.7.5 Fire alarms, trouble alarms, and supervisory signals shall be transmitted by zone, for annunciation at the RCC, in accordance with NFPA 72.
- 2.9.7.6 If located within a building having other occupancies, the RCC shall have at least one summary alarm for fire or evacuation notification, initiated from any part of the building.
- 2.9.7.7 An EMP shall be located at the primary entrance, in accordance with the requirements of the AHJ.

2.9.8 Mechanical Systems

- 2.9.8.1 The RCC HVAC systems shall be physically and operationally separated from HVAC systems serving any other occupancy.
- 2.9.8.2 Emergency smoke removal capability shall be provided for the RCC. The smoke removal system shall be designed to utilize 100 percent outside air make-up and shall have the capability of providing a minimum of 6 air changes per hour.
- 2.9.8.3 Battery storage or similar ancillary rooms shall be installed and ventilated per IFC.
- 2.9.8.4 Other mechanical systems shall be in accordance with the MSBC.

2.9.9 Electrical Requirements

- 2.9.9.1 Electrical equipment and wiring materials and installation shall conform to the requirements of the MSBC.
- 2.9.9.2 A separate on-site emergency power system shall be provided per the MSBC for the RCC so that the loss of utility electrical power shall not impair any of the RCC function.

2.9.10 Communication Transmission Medium

- 2.9.10.1 Transmission of fire alarms, and supervisory signals from transit facilities to the appropriate central supervising station may be accomplished using direct-line cables or a cable transmission subsystem. It is permissible for operational signals to share transmission media with fire signals.
- 2.9.10.2 Whatever means is used for transmission of fire signals, the following requirements shall be met:
- The transmission media shall conform to the requirements of NFPA 72
 - Common use of transmission media shall not impair the fire alarm function

2.10 OPERATIONS

To ensure the safety and security of passengers and employees, and to provide efficient and reliable service, planning for operational safety shall be accomplished. This section defines the Fire/Life safety requirements during operations planning.

2.10.1 Operational and Maintenance Procedures

- 2.10.1.1 Operational procedures, including an inspection and maintenance program shall be established to ensure that all Fire/Life safety related equipment is in proper condition, and that personnel are familiar with the use and care of safety related equipment and emergency preparedness procedures.
- 2.10.1.2 CCLRT, with the assistance of the emergency response organizations, shall have primary responsibility for accomplishing the above objectives.
- 2.10.1.3 A program of testing and inspection of Fire/Life Safety related equipment shall be developed including a specific program for verifying that necessary maintenance and/or repair is performed.

-
- 2.10.1.4 The testing and inspection program shall be in accordance with applicable sections of NFPA standards, the MSBC, IFC, and manufacturer recommendations.
- 2.10.1.5 A Fire/Life Safety equipment maintenance program per IFC and local regulations shall include, but not be limited to:
- Manual or portable fire suppression equipment
 - Fire alarms and detection systems
 - Automatic fire suppression systems
 - Auxiliary fire service equipment
 - Emergency communication systems
 - Emergency lighting
 - Elevators and escalators
 - Backup Power Supply
 - Power removal and restoration equipment, including ETS'
 - Communications system equipment, facilities, and procedures
 - Electrification system familiarization
 - Identification of personnel authorized to make decisions in emergencies
- 2.10.1.6 CCLRT, in conjunction with the appropriate local emergency response organizations, shall develop and implement a training program for system operations personnel. This training program shall address all functions to be performed during emergencies on transit system.

2.10.2 Emergency Procedures

- 2.10.2.1 Safe and efficient operation of the transit system shall require the anticipation of, and planning for, system emergencies. CCLRT, in conjunction with the appropriate local emergency response organizations, shall establish an emergency preparedness plan and the necessary procedures for the control and coordination of all anticipated emergency response activities.
- 2.10.2.2 Development of an Emergency Preparedness Plan (EPP) and supporting procedures shall include, but not be limited to, consideration of the emergency scenarios described in NFPA 130.
- 2.10.2.3 The EPP will include the information required by Chapter 9 of NFPA 130. The EPP will address three levels of action, based on the degree of severity of the emergency. The degrees of severity are as follows:
- Major regional disasters that may affect other areas besides the transit system
 - Major transit system incidents that may affect system-wide operations

-
- Minor transit incidents, such as small fires, medical emergencies, and other similar emergencies that may not affect system-wide operations, but may affect individual train operations

2.10.2.4 Depending upon the nature of the emergency, the appropriate local emergency response organizations shall be notified. These agencies are identified, but are not limited to those in Section 9.5 of NFPA 130. As part of the emergency preparedness plan, CCLRT shall maintain an up-to-date listing of the local emergency response organizations' liaison personnel. The list shall be reviewed and tested quarterly to determine for accuracy and completeness.

2.10.2.5 The RCC staff members shall be trained and qualified in the use of the equipment and systems provided, and in the implementation of operational procedures and the emergency preparedness plan. Procedures shall be developed that addresses the following:

- The use of the direct-line communication capability with emergency response organizations during transit system emergencies
- The use of an Alternate RCC site should the main RCC be out of service
- Maintenance of essential RCC functions during a fire or other emergency involving an adjoining or adjacent structure
- Effective utilization of fire detection, protection, and suppression equipment to minimize detection and extinguishing time for any fire in the RCC facility

2.10.3 Training, Exercises, Drills, and Critiques

CCLRT and emergency response organizations' personnel shall be familiar with all aspects of the EPP and shall be trained to coordinate their functions efficiently during an emergency. Simulations, drills, and critiques will be conducted. Written records shall be maintained.

2.10.4 Traction Power Removal and Restoration

2.10.4.1 Procedure for removal and restoration of traction power shall be included in the EPP. The RCC shall be contacted whenever it is necessary to trip an emergency traction power disconnect device. The information to be given to the RCC shall be established in the Emergency Procedures Plan and include the information required by NFPA 130.

2.10.4.2 Control of OCS power shall revert to the RCC when the shutdown of OCS power is no longer required by the involved emergency response organization(s).

2.10.5 Training

- 2.10.5.1 CCLRT, with the support of the appropriate local emergency response organizations, shall establish training programs and coordinate the Fire/Life Safety interfaces necessary to educate and/or familiarize transit system employees and emergency response personnel with transit system equipment, its operations, and the emergency preparedness plan and procedures.
- 2.10.5.2 CCLRT and the appropriate local emergency response organizations shall jointly develop and implement a comprehensive joint training and indoctrination program for emergency response personnel. This program shall include, but not be limited to:
- Communication procedures and facilities
 - System facilities indoctrination
 - Passenger vehicle indoctrination
 - Electrification system
 - Means of emergency access and egress
 - System fire detection, alarm, and control systems
 - Familiarization with yard and maintenance facilities
 - Arrangements for fire equipment inspection and testing
 - Emergency medical aid procedures and policies
 - Identification of personnel authorized to make decisions in emergencies
 - Emergency preparedness plans and procedures
 - Training of transit employees

2.11 APPLICABLE STANDARDS, CODES AND GUIDELINES

System Safety and Fire/Life Safety design provisions shall be in accordance with the following standards and guidelines, to the extent used herein. The documents used shall be the latest edition, unless a specific code or standard is identified.

- American Society of Testing Materials (ASTM) 119E and 136
- Minnesota Accessibility Code
- Institute of Electrical and Electronics Engineers (IEEE) 383
- National Fire Protection Association (NFPA) Standard Nos. 10, 13, 14, 70, 72, 101, 130.
- Occupational Safety and Health Act (OSHA)
- Minnesota State Building Code (MSBC)
- International Fire Code (IFC)
- International Mechanical Code (IMC)

3.0 TRACK GEOMETRY AND TRACKWORK

3.1 GENERAL

3.1.1 Introduction

This section sets forth the criteria that will govern the geometric design of the horizontal and vertical alignment of the Central Corridor Light Rail Transit (CCLRT) System guideway. Also herein is the criteria that will govern trackwork design, materials and construction standards for the CCLRT system.

Exceptions to the requirements specified will not be allowed without approval from the MET COUNCIL. Granting of such approval will be considered only upon a clear and compelling demonstration that these requirements cannot be reasonably attained.

Construction plans and specifications shall generally follow the AREMA Manual for Railway Engineering and Portfolio of Trackwork Plans, and the APTA Guidelines for Design of Rapid Transit Facilities, except as modified herein to reflect the physical requirements and the operating characteristics of the Central Corridor LRT system.

In addition, where the CCLRT operates in a public street or shares its right-of-way with buses, the design requirements and concepts of Mn/DOT, AASHTO, counties and local municipalities shall also be utilized.

3.1.2 Track Gauge and Construction Tolerances

Standard track gauge shall be of 4 foot, 8 - 1/2 in. For 115 RE tee rails, track gauge is to be measured 5/8 inch below the top of rails. See Figure 3-5. LRT track construction tolerances shall comply with Figure 3-1.

Where restraining rail is used, track gauge shall be modified in accordance with section 3.4.7.

3.1.3 Types of Track

Trackwork shall be appropriate to the site conditions and environment in which it will be constructed, and so designed that maintenance requirements will be minimized. The following types of track construction are to be used for the CCLRT system.

In selecting the appropriate trackwork design, consideration of factors such as safety, stray current, ride comfort, noise, and vibration must not be overlooked. Also, the relationship of trackwork design to the design of other system elements including train control, special trackwork, drainage, and Traction Electrification Systems must be recognized and accommodated early in the design process.

Three distinct types of primary track construction may be encountered in the CCLRT system: ballasted, direct fixation and embedded. The design of the trackwork varies to some degree within each type of construction

Development of the track requirements included consideration of maintainability, reliability, parts standardization, capitol costs and maintenance costs.

Ballasted Track. This shall be the primary type of track construction used for at-grade segments and bridges less than 150 feet in length when bounded on each end by at-grade sections of ballasted track.

Ballasted track, unless specified to the contrary elsewhere in this design criteria manual, shall be constructed with continuous welded rail (CWR).

See Section 3.4, Figures 3-11, for additional ballasted track requirements.

Ballasted track will not allow use of the track guideway by rubber-tired vehicles.

Embedded Track. This shall be the primary type of track construction used where the LRT system shares the roadway with rubber-tired vehicles either in mixed traffic or in locations where only emergency vehicles will be permitted to travel along the trackway. Embedded track, unless specified to the contrary elsewhere in this design criteria manual, shall be constructed with continuous welded rail (CWR).

Embedded track shall be used in selected urban areas where ballasted track is not compatible with the existing or proposed streetscape.

See Section 3.4.13 below for additional Embedded track requirements.

Direct Fixation Track. This shall be the primary type of track construction used for tunnels and for aerial structures more than 150 feet in length. It may also be used in specific applications where ballasted or embedded track construction is not reasonably applicable.

See Section 3.4.14 below for additional DF track requirements.

Direct Fixation track, unless specified to the contrary elsewhere in this design criteria manual, shall be constructed with continuous welded rail (CWR).

DF track will not allow use of the track guideway by rubber-tired vehicles.

Dual Block Track, also referred to as dual-block concrete tie track, is an encased-tie, direct fixation system that may serve as an acceptable alternative to the conventional fastener-on-plinth direct fixation system. Dual block track utilizes individual concrete tie blocks. The elastometric pads and blocks are enclosed in a rubber boot before installation. After temporary supports have been erected to hold the rail at proper profile, alignment and gauge, with tie

blocks and rail fasteners attached, encasement concrete is poured around the rubber boot. See Figure 3-6.

3.1.4 Design Speeds

The civil design speed for the alignment shall be based upon the normal operating speeds as provided on speed-distance profiles generated from the train performance simulation program and should be the maximum achievable speed for the alignment constraints. The maximum normal operating speed is 55 mph. Operating speeds for LRT in urban settings is often times equivalent to (or slightly more than) design speed or posted speed of adjacent roadway. When establishing design speeds for LRT, consideration must be given to timing coordination with traffic signals that control adjacent roadway travel lanes.

Where cost, geometric or other physical constraints permit, the designer shall establish alignment, superelevation, and track clearance conditions that will permit optimized design/travel speeds in the future by adjusting the actual superelevation.

3.1.5 Stray Current Control

Control of stray currents to earth ground, resulting from using running rails as the negative return of the traction electrification system must be taken into consideration. The trackwork design must be coordinated with the requirements of the corrosion control criteria as given elsewhere in this design criteria manual and mitigation measures, appropriate to the anticipated magnitude and extent, shall be employed to minimize stray currents.

The primary method of mitigating stray currents is to electrically isolate the rail from adjacent ground. This is typically achieved using insulated rail fasteners for direct fixation track and ballasted track and encasing the rail in an insulating material such as rail boot for embedded track.

3.2 HORIZONTAL TRACK ALIGNMENT

3.2.1 General

The mainline horizontal alignment shall consist of tangent sections connected by circular curves with spiral transition curves.

The LRT track alignment for each line section shall be stationed along the centerline of the eastbound track. The eastbound track shall be the primary control line for locating all other system facilities along the route. Separate stationing shall be used for the westbound track. Stationing shall increase from west to east.

Sufficient and appropriate lateral offset must be provided between LRT guideway (LRV) and adjacent fixed or protected objects. Refer to vehicle dynamic envelope (VDE) calculations in Appendix A, LRV criteria in Section 8, Fire Life Safety (Emergency Walkway) design criteria in Section 2, and Figures 3-9 and 3-10 in this Section.

3.2.2 Tangent Sections

The minimum length of tangent track between curved sections (except those with compound curves) shall be as follows:

<u>Condition</u>	<u>Tangent Length</u>
Desirable:	100 ft or 3 times the design speed (mph) of the higher speed curve, (whichever is larger)
*Minimum:	45 ft

(*Not to be exceeded without Met Council approval.)

The horizontal and vertical alignment should be tangent at all station platforms throughout their entire length. Minimum station platform length shall be 270 feet, assuming no vertical circulation elements (VCE) are provided on the station platform. Station platforms with VCE may be longer than 270 feet. Minimum width for center station platforms is 20 feet. Minimum width for side station platforms is 12 feet. Also see Section 8 for additional details relative to station platforms. The tangent shall extend beyond either end of the platform as follows:

<u>Condition</u>	<u>Tangent Length</u>
Desirable:	60 ft
*Minimum:	45 ft

(*Not to be exceeded without Met Council approval.)

For tangent distance requirements near special trackwork, see section 3.4.12.

3.2.3 Curved Sections

3.2.3.1 Circular Curves

Circular curves shall be specified by their radius. Degree of curve, where required for calculations, shall be defined by the ARC definition of curvature, as determined from the following formula:

$E_a = 4$ inches desirable
6 inches absolute

$E_u = 3$ inches desirable
4.5 inches absolute

Desirable values of actual superelevation shall be determined by the following formula:

$$E_a = \frac{2.64 V^2}{R} - 0.67$$

Calculated values for actual superelevation shall be rounded up to the nearest $\frac{1}{4}$ inch. For an equilibrium superelevation of 1 inch or less, no actual superelevation shall be applied.

Actual superelevation shall be attained and removed linearly through the full length of the spiral transition curves (See Section 3.2.3.3 below) by raising the outside rail while maintaining the inside rail at the profile grade.

Superelevation will not be required in yard and service tracks, except at particular locations for specific purposes, and only with the approval of the Metropolitan Council.

The maximum allowable superelevation for track shared with rubber tire vehicles is as follows:

Desirable maximum	0 inch
Absolute maximum	1 inch.

3.2.3.3 Spiral Transition Curves

Spiral transition curves shall be provided between mainline horizontal circular curves and tangents or between different degrees of curvature for compound curves to develop the superelevation of the track and limit the lateral acceleration during the horizontal transition of the LRV as it enters the curve. See Figure 3-3 for spiral nomenclature.

The minimum length of spiral s (L_s) shall be the greatest length determined from the following formulas:

$$L_s = 1.22 E_u V \quad (1.63 E_u V \text{ desirable})$$

$$L_s = 33 E_a$$

$$L_s = 1.17 E_a V$$

$$L_s = 30'$$

Where: L_s = Length of spiral curve (in ft)

If the minimum spiral length obtained above is not practical, then reduced spiral lengths and superelevation runoff rates may be used, provided Metropolitan Council approval has been obtained.

The length of spiral (L_s) shall be rounded up to the next 10 foot increment.

As a practical consideration, spiral transition curves and superelevation are not required for circular curve radii over 10,000 feet.

Individual spiral length (L_s) shall not be greater than the length of adjoining circular curve. See Sect. 3.2.3.1 for criteria on minimum length of circular curve.

3.2.3.4 Reverse Curves

Where extremely restrictive horizontal geometry makes it impossible to provide sufficient tangent length between reversed superelevated curves, the curves may meet at a point of reverse spiral. The reversed spirals shall be designed so that:

$$L_{s1} \times E_{a2} = L_{s2} \times E_{a1}$$

Where: E_{a1} = actual superelevation applied to the first curve (in inches)
 E_{a2} = actual superelevation of the second circular curve (in inches)
 L_{s1} = the length of the spiral leaving the first curve (in feet)
 L_{s2} = the length of the spiral entering the second curve (in feet)

The superelevation transition between reversed spirals shall be accomplished by sloping both rails of the track throughout the entire transition spiral as shown on Figure 3-2. Note that through the entire transition, both rails will be at an elevation above the theoretical profile grade line. Actual superelevation applied on the left and right rail will be equal at the point of reverse spiral.

This method of superelevation transition creates additional design considerations including an increased ballast section width at the point of reverse spiral and possible increased clearances. Such issues shall be investigated in detail and any impacts identified in the exception application to the Metropolitan Council.

3.2.3.5 Compound Circular Curves

Where compound curves are used, they shall be connected by a spiral transition curve. The absolute minimum spiral length shall be the greater of the lengths as determined by the following, rounded up to the next 10 foot increment:

$$L_s = 33 (E_{a2} - E_{a1})$$

$$L_s = 1.22 (E_{u2} - E_{u1}) V \quad [1.63 (E_{u2} - E_{u1}) V \text{ desirable}]$$

$$L_s = 1.17 (E_{a2} - E_{a1}) V$$

Where: E_{a1} = actual superelevation of the first circular curve, in inches
 E_{a2} = actual superelevation of the second circular curve, in inches
 E_{u1} = unbalanced superelevation of the first circular curve, in inches
 E_{u2} = unbalanced superelevation of the second circular curve, in inches

Spiral transition curves connecting compound curves are not required when both $(E_{a2} - E_{a1})$ and $(E_{u2} - E_{u1})$ are less than 1/2" inch.

For compound circular curves without a spiral, the change in superelevation shall be run entirely within the curve of the large radius.

3.3 VERTICAL TRACK ALIGNMENT

3.3.1 General

The vertical alignment shall be composed of constant grade tangent segments connected at their intersection by parabolic curves having a constant rate of change in grade. The nomenclature used to describe vertical alignments shall be consistent with that illustrated in Figure 3-4.

The profile grade line in tangent track shall be along the centerline of track between the two running rails and in the plane defined by the top of the two rails. In curved track, the inside rail of the curve shall remain at the profile grade line and superelevation achieved by raising the outer rail above the inner rail.

Preferred Minimum Clearances over Track

Preferred Minimum vertical clearance for structures over/above track grade shall be 18 foot-0 inches (18'-0"), as measured from top of rail to contact wire height. For additional information on required vertical clearance to OCS contact wire, and determine required vertical distance from contact wire height upward to low structure/obstruction, refer to National Electric Safety Code Ch. 23, AREMA Ch. 33, CCLRT Design Criteria Manual Chapter 10, and consultation with CCPO OCS design engineer.

Absolute Minimum Clearance over Track

In locations where 18 foot -0 inches (18'-0") vertical clearance is not practical, as measured from top of rail to contact wire height, refer to National Electric Safety Code Ch. 23, AREMA Ch. 33, CCLRT Design Criteria Manual Chapter 10, and consultation with CCPO OCS design engineer.

3.3.2 Grades

The following profile grade limitations shall apply:

Mainline tracks

- Maximum (sustained grade unlimited length) 4.0%
- Maximum (sustained grade with up to 2500 feet between PVI's of vertical curves) 6.0%
- Minimum (for drainage on direct fixation and embedded track) 0.20%
- Minimum (for drainage on tie & ballast track) 0.00%

For mainline tracks, the desired minimum length (L_g) of constant profile grade between vertical curves shall be determined as follows:

$$L_g = 3V$$

$$L_g = 100' \text{ (desirable minimum)}$$

$$L_g = 50' \text{ (absolute minimum)}$$

Where: L_g = Length of constant profile grade (ft)

V = Design velocity (miles per hour)

Station Area

- Desirable 0.0%
- Preferred Maximum 1.0%
- Absolute Maximum 2.0%

No minimum grade is specified at passenger stations provided adequate track drainage can be maintained. Due to physical constraints, the existing street

profile may strongly influence the profile grade within the station. The longitudinal profile grade shall be restricted to a maximum of 2.0%.

The vertical distance between top of rail and top of platform shall remain uniform at 14 inches throughout the platform length as well as an additional 45 feet beyond both ends of the platform.

Special Trackwork

- Desirable 0.0%
- Preferred Maximum 1.5%
- Absolute Maximum 4.5%

Yard Lead Tracks

- Desirable 0.0%
- Maximum 1.0%

Yard Storage & Pocket Tracks

- Desirable 0.0%
- Maximum 0.25%

All tracks entering the yard shall either be level, sloped downward away from the mainline, or dished to prevent rail vehicles rolling from the yard onto the mainline. For yard secondary tracks, it is desirable to have a slight grade, maximum 1.0 percent and minimum 0.35 percent, to facilitate good track drainage at the subballast level.

For yard lead tracks, the desired minimum length of constant profile grade between vertical curves shall be determined as follows:

$$L_g = 3VL_g = 3V$$

$$L_g = 100' \text{ (desirable minimum)}$$

$$L_g = 50' \text{ (absolute minimum)}$$

Where: L_g = Length of constant profile grade (ft)

V = Design velocity (miles per hour)

3.3.3 Vertical Curves

All changes in grade shall be connected by vertical curves. Vertical curves shall be defined by parabolic curves having a constant rate of change in grade.

3.3.3.1 Length of Vertical Curves

The minimum length of vertical curves shall be determined as follows:

$$\text{Desirable length} \quad LVC = 100A$$

Absolute minimum length of vertical curves shall be determined by the formulas below and shall not be less than 100 feet in length:

$$\text{Crest curves} \quad LVC = \frac{AV^2}{25}$$

$$\text{Sag curves} \quad LVC = \frac{AV^2}{45}$$

Where: LVC = length of vertical curve, in feet
A = $(G_2 - G_1)$ algebraic difference in gradients connected by the vertical curve, in percent
 G_1 = percent grade of approaching tangent
 G_2 = percent grade of departing tangent
V = design speed, in mph.

The length of vertical curve shall be rounded up to the next even 10 foot length. Both sag and crest vertical curves shall have the maximum possible length, especially if approach and departure tangents are long. Vertical broken back curves shall be avoided.

Minimum vertical curve length and/or design speed may be governed by the overhead contact system due to the maximum permissible rate of separation or convergence between the track grade and the contact wire grade. Coordination with the OCS designer is required to assure compliance with this limitation.

Equivalent radius of vertical curves shall not be less than 1200 feet for sag vertical curves (related to LRV spec's.) or 900 feet for crest vertical curves.

3.3.3.2 Reverse Vertical Curves

Reverse vertical curves may be used provided the minimum length of each vertical curve is not less than that defined by Section 3.3.3.1 above

3.3.3.3 Compound Vertical Curves

Compound or unsymmetrical vertical curves may be used provided the requirements of Section 3.3.3.1 above are met.

3.3.3.4 Combined Vertical and Horizontal Curves

Where possible, areas of combined vertical and horizontal curvature shall be avoided. Where areas of combined vertical and horizontal curvature cannot be avoided, the combined geometrics shall not be more restrictive than an 82 ft radius horizontal curve and a 1640 ft equivalent radius vertical curve either crest or sag.

Equivalent radius of vertical curvature can be calculated from the following formula:

$$R_v = \frac{LVC}{0.01(G_2 - G_1)}$$

Combinations that approach minimum horizontal curve radius, maximum gradient and maximum unbalanced superelevation at the same location or in close proximity shall be avoided.

3.4 MAINLINE TRACK

3.4.1 Drainage

Drainage design shall be in accordance with the requirements set forth elsewhere in this design criteria document, and shall facilitate rapid removal of water from the trackbed to ditches or other drainage facilities. The design shall insure that water does not flow or backup into the track structure at design capacity.

Drainage should take into consideration areas adjacent to the tracks where elements such as streets, parking facilities, roads, landscaping, walls, etc., may have an impact on the drainage of the trackway area. Trackway drainage design shall be based at least in part, on a comprehensive geotechnical engineering analysis. See Reference Documents, for preliminary information and recommendations.

For embedded track drainage requirements see Section 3.4.13 below.

3.4.2 Subgrade

The subgrade shall provide a stable, well-drained foundation of sufficient strength to support the track structure and minimize track maintenance requirements. Emphasis shall also be placed on uniformity of subgrade support to avoid differential settlement resulting in deterioration of the track alignment, profile or cross-level.

A comprehensive geotechnical engineering analysis shall be performed to determine the most appropriate measures necessary to achieve these requirements.

3.4.3 Sub-Ballast and Geotextile

Ballasted tracks shall have an 8 inch layer of sub-ballast installed on top of the subgrade. The sub-ballast material shall conform to AREMA requirements.

The sub-ballast layer shall slope downward at 1:48 from a center crown point located between the tracks of double track segments and at the centerline of track for single track segments.

In locations where MSE retaining walls are being implemented, the sub-ballast layer shall slope upward from a center valley point located between the tracks of double track segments. See Figure 3-13.

Where conditions indicate subgrade capacity or drainage improvements are warranted, a layer of geotextile shall be utilized between the subgrade and sub-ballast. Geotextiles shall conform to AREMA requirements, and be selected in accordance with the criteria given therein. Geotechnical analysis is required to determined excavation and backfill requirements below the sub-ballast.

3.4.4 Ballast

Mainline ballasted track shall use AREMA (4a) ballast. Ballast shall conform to AREMA requirements and shall be crushed granite, traprock or quartzite. Crushed slag ballast will not be permitted.

A minimum depth of 12 inches of ballast shall be used between the bottom of tie and the top of the sub-ballast measured below the running rails. Shoulder ballast shall extend 18 inches beyond the ends of the ties and parallel to the plane formed by the top of the rails and then slope downward to the sub-ballast at a 1V:2H slope. The final top of ballast elevation shall be 1 inch below the top of tie, when compacted. See Figure 3.11.

On bridge decks with ballasted track, a minimum depth of 8 inches of ballast shall be used with 12" shoulder ballast.

3.4.5 Cross Ties

Mainline tracks shall use concrete cross ties spaced 30 inches center to center. Concrete cross ties shall be a proven design for transit applications and shall conform to AREMA specifications. The concrete cross tie shall provide for a rail seat with a 40:1 cant. Switch ties shall be timber hardwood ties of various lengths conforming to the requirements of the turnout used. Anti-splitting devices shall be used on all timber ties.

3.4.6 Rail

Ballasted track, direct fixation track, and embedded track shall use new 115 RE continuously welded rail; control-cooled carbon steel manufactured in accordance with current AREMA specifications (See Figure 3-5).

Embedded track shall utilize a preformed rail boot encasing 115 RE rail to form a flangeway similar to the flangeway that would be created using Ri 59 girder rail. See Figure 3-6 and Figure 3-14.

Premium rail, heat-treated or alloy, shall be used in all special trackwork, station areas to 100 feet past the ends of the platform, and on all curves of radii equal to or less than 500 ft. Premium rail shall not be installed on seldom used emergency or storage tracks, even though they may satisfy the above criteria. Premium rail may be used, with Metropolitan Council approval, in other locations where excessive rail wear is anticipated.

Premium rail shall be used on all mainline tracks greater than 4% grade.

Rails in short radius curves shall be pre-curved using standard shop practices. Rail shall be pre-curved under the following circumstances:

- 115 RE rail with horizontal radius less than 350-foot or vertical curve equivalent, less than 1200 feet for sag vertical curves (related to LRV spec's.) or 900 feet for crest vertical curves.

3.4.7 Restraining and Emergency Guard Rails

Restraining Rail

Mainline ballasted and direct fixation track having a centerline radius of less than or equal to 500 feet and other specific locations where restraining rail would prove to be beneficial shall have restraining rail added to the inside running rail. Tracks having a centerline radius less than or equal to 100 feet shall require restraining rail on both running rails.

Restraining rail design shall have 115 RE guard rail mounted inside the low rail in accordance with AREMA plans and specifications. The restraining rail shall be fastened to either the concrete cross-ties, concrete track slab, or the direct fixation track plinth, as applicable. The Flangeway shall be set at 1-5/8" wide unless the selected design of LRV wheel flange requires otherwise. Where the track geometrics do not include a spiral, the restraining rail assembly shall extend beyond each end of a guarded simple curve (no spirals) a minimum distance of 13 33 feet. These configurations should be restricted to non-revenue track.

Where the track geometrics include a spiral (all revenue track), the curve guarding restraining rail shall extend a minimum distance of 13 feet beyond (into the tangent track) the Tangent-Spiral point.

When restraining rail is used in embedded track applications, a filler material shall be used to prevent debris from entering the gap between running and restraining rails.

Strap Rail type restraining rail shall not be used.

Restraining Rail shall be SWR or jointed, to prevent rail end offset.

Track gauge shall be widened by 1/4 inch at all locations where restraining rail is used. Although the restraining rail is primarily designed to reduce rail wear, it also inhibits lateral vehicle movement, therefore no allowance will be made in the clearance calculation for the gauge widening.

Emergency Guard Rail

Emergency guard rails shall be installed on aerial structures and retained fill with a vertical drip of more than 3 feet, with ballasted track or DF track, or other locations where derailment could be catastrophic, including approaches to tunnels and other major structures.

Emergency Guard rails shall extend 60 feet ahead of the beginning of the structure or area being protected on the approach end, and 60 feet beyond on the departure end.

Emergency guard Rail shall be fabricated from 100# to 115# second-hand rail with second-hand joint bars and new track bolts and installed in accordance with the Directive Drawings. Emergency Guard rails should be no lower than 1 inch below top of the running rail and approximately 10 inches from the gauge side of the running rail.

3.4.8 Rail Seats and Fastenings

For concrete tie ballasted track, rail shall be secured to the ties by use of insulated elastic rail clips capable of providing the required lateral and longitudinal restraint. An elastomeric pad shall be placed between the rail and concrete tie. The fastening system shall provide electrical insulation properties capable of meeting the applicable requirements specified elsewhere in this design criteria.

For direct fixation track, rail shall be secured to deck or base slab using a fastening system that will provide the required lateral and longitudinal restraint for continuous welded rail and the electrical insulation required for the negative return current and the proper operation of track signal circuits.

Direct fixation rail fasteners shall have the following longitudinal spacing:

- Tangent or curved track with a radius >500 feet 30-inch centers;
- Curved track with a radius <500 feet and >300 feet, 27-inch centers; and
- Curved track with a radius <300 feet, 24-inch centers;

Direct fixation design used with tee rail shall provide a 40:1 cant of the rail.

For timber ties the standard fastening system shall consist of elastic rail clips and steel tie plates with a 40:1 cant that are fastened to the ties with lag screws. Special provisions for control of stray current leakage at the tie plate should be considered.

3.4.9 Rail Welds

Rail shall be welded into continuous welded rail (CWR) strings of site-specific length by the electric flash-butt process in accordance with AREMA specifications. The ends of CWR strings and all special trackwork connections are to be field-welded (exothermic) together according to AREMA specifications.

3.4.10 Bolted Rail Joints

Bolted rail joints shall not be used except in those locations where it is absolutely necessary and only with Metropolitan Council approval.

When approved for use; rail ends at the joint shall be end-hardened and joint bars, of the 36 inch six-hole type, track bolts, nuts and lock washers shall conform to current AREMA standards.

3.4.11 Switch Heaters

Electric switch heaters shall be installed in all turnouts of both mainline and yard tracks to reduce the possibility of switch malfunction due to snow and ice. Include heaters in switch rod areas.

3.4.12 Special Trackwork

Special trackwork shall be manufactured and installed in accordance with AREMA plans and specifications. Frogs and flangeways shall be designed to accommodate the LRT wheel profile as shown in Figure 8-1.

The preferred location of special trackwork is in ballasted at-grade areas. Single crossovers shall be used in lieu of double crossovers unless space restrictions dictate their use.

Special trackwork in embedded track shall be kept to an absolute minimum; however, when it must be so located, it shall be designed to reduce the exposure of pedestrians to the operating mechanisms. Switch points shall not be located in areas designated as pedestrian crossings.

Special trackwork shall be located on vertical and horizontal tangents. In certain circumstances, special trackwork may be used on curves, but only with review and approval by the Metropolitan Council. Special trackwork shall not be superelevated.

The minimum length of tangent between any point of switch (P.S.) and a station platform shall be 45 ft.

The minimum horizontal and vertical tangent distance preceding a point of switch (P.S.) shall be as follows:

<u>Condition</u>	<u>Tangent Length Preceding a P.S.</u>
Desirable	100 feet
*Minimum	45 feet
*Absolute Minimum	stock rail projection plus ½ of the adjacent rail joint.
	Note: Only to be used where LRV will not operate through diverging side of both turnouts.
Yard, Absolute Minimum	10 feet
	Minimum horizontal/vertical tangent distance between adjacent P.S.

(*Not to be exceeded without Metropolitan Council approval.)

The minimum distance measured from a point of switch through a turnout to a horizontal or vertical curve shall be as indicated in Figure 3-7.

As special trackwork is a source of noise and vibration, its location shall be selected to minimize their effect and the need for special noise or vibration mitigation measures.

Operating speed through turnouts shall be as indicated in Figure 3-8. Turnouts and crossovers for various applications shall be selected in accordance with the following criteria:

- No. 10 turnouts (19'-6" curved switch points) may be used when frequency of use and higher speed operation is necessary;

-
- No. 8 turnouts (13'-0" curved switch points) shall be the standard mainline turnout in ballasted at-grade track for terminal and emergency crossovers, and as yard connections;
 - No. 8 turnouts with flexible manganese switch tongues and solid manganese frogs for embedded track;
 - No. 6 turnouts (13'-0" curved switch points) shall be used on the mainline in areas where space limitations prevent the use of No. 8's;
 - No. 5 turnouts (11'-0" straight switch points) shall be used in yard and non-revenue service applications;
 - All ballasted track turnouts shall use AREMA Point Detail 5100 with graduated risers and rail-bound manganese frogs with heat-treated or alloy steel guardrails.
 - All embedded track turnouts shall use double tongue flexible switches and rolled section and block or solid manganese steel frogs. Embedded track switch points shall be bolted to closure rails with a heel block.

Special drainage provisions shall be made in embedded track turnouts to preclude standing water in flangeways, tongue areas, and switch-throwing mechanisms.

Rail fasteners for use in direct fixation special trackwork shall be of a design that is compatible with the standard fastener used in conventional direct fixation track.

3.4.13 Embedded Track

The embedded track structure design shall incorporate 115 RE tee rail and electrical isolation system fastened to a concrete slab and embedded in concrete pavement in conjunction with a roadway surface level with the top of the running rails.

Embedded track shall utilize a preformed rail boot encasing 115 RE rail to form a flangeway similar to the flangeway that would be created using Ri 59 girder rail. See Figure 3-6.

Track drains shall be used in embedded track areas to properly drain the rail flangeways and the pavement surface between the rails. Drainage pipe connections shall be to the closest storm drain lines. When possible, track drains shall be located in tangent track. The adjacent surface pavement shall be designed so surface water will drain away from the track.

Track drains shall be spaced generally every 500 to 600 ft on tangent track. A minimum of one drain per track per block 300 feet shall be located on the uphill side of each intersection. Drains shall also be located at the low points of the profile.

In areas of special trackwork, particular attention is to be directed to providing drainage for the special trackwork units and switch-throwing mechanisms including rail heaters to melt snow and ice from the moving parts of the switch area.

Transition ties and slabs shall be installed at interfaces between embedded track and ballasted track sections.

3.4.14 Direct Fixation Track

Direct fixation track structure design shall consist of a concrete base slab, a second pour concrete plinth pad and anchorage system capable of providing proper track geometry and the required electrical isolation and noise and vibration attenuation properties.

Direct fixation design for aerial structures shall accommodate CWR characteristics. CWR shall not be terminated on and shall extend beyond the aerial structure such that a minimum of 110 rail fastenings or ties are engaged.

Transition ties and slabs shall be installed at interfaces between direct fixation track and ballasted track.

3.4.15 Grade Crossings

Mainline grade crossings shall be made of durable, long lasting pre-cast concrete panels with compatible rubber flangeway fillers. Grade crossing panels shall be constructed with due regard to access for track maintenance, electrical isolation, non-interference with electrical track circuits or rail fastenings, tire adhesion, and slip resistance for pedestrians.

Grade crossings shall, wherever practical, be located on tangent track. Grade crossings shall not be located at special trackwork areas. Grade crossings required in curved track shall be custom designed and manufactured to conform with the rail curvature. Rail joints shall not be located in grade crossings.

3.4.16 Crosswalks

Crosswalks shall be provided at areas where pedestrians will be crossing mainline tracks. Crosswalks shall be located on tangent track, if possible, and away from special trackwork areas.

Crosswalks shall be prefabricated and made of materials sufficiently durable for pedestrian traffic and vehicular traffic if located directly adjacent to a street crossing. Crosswalk panels shall be constructed with due regard to access for track maintenance and to noninterference with electrical track circuits and rail fastenings. Special care shall be taken to ensure a safe, slip resistant walking surface.

Crosswalk design shall meet the ADA requirements for flangeway width for wheelchair crossing and should provide “sound or cane” warning for sight impaired individuals.

3.4.17 Maintenance Access Point

Access points for maintenance vehicles shall be located on tangent track and be constructed of durable grade crossing materials.

All maintenance access points shall be adequately secured to prevent unauthorized entry.

3.4.18 End of Track Bumping Posts

Bumping posts shall be installed at the ends of all mainline tracks. They shall be energy absorbing friction devices that are clamped to the running rails and shall be designed for an LRV impact velocity of 5mph with a maximum deceleration rate of 0.3g. Bumping posts shall be designed to engage the vehicle's anti-climber and apply a retardation force not exceeding its yield strength.

3.4.19 Transition Slabs

Reinforced concrete transition slabs shall be installed at the ends of aerial structures and tunnels and at locations where the track transitions from embedded or DF to ballasted track and vice versa to provide a smooth transition from one track modulus area to another. The transition slab shall be located below the track ties and gradually slope to achieve an adequate transition between the two different track modulus areas. Care should be taken to ensure proper drainage at the transition from embedded or DF track to ballasted track.

3.4.20 Rail Expansion Joints

During final design, locations where rail expansion/contraction is anticipated to present a problem (i.e. bridges and certain sharp curves on ballasted track) shall be analyzed for methods of control. If mechanical rail expansion joints are used, the expansion capacity of the joints shall be greater than the anticipated rail movement within the full range of rail temperatures.

3.4.21 Insulated Joints

Insulated Joints (IJs) shall be used where required by the signal system. IJs provide electrical isolation between sections of running rail while maintaining the rails' mechanical integrity. The precise location of IJs shall be coordinated with the signal system design.

IJs shall be provided, installed, and tested per AREMA standards. IJs shall be shop fabricated, bonded units wherever possible and welded into place. Field assembly in accordance with manufacturer's recommendations may also be considered for limited, unavoidable applications. IJs shall be electrically tested to insure a minimum of 10 megohms resistance from rail-to-rail and from each rail to each sidebar, when tested for 5 seconds per test using a 500 VDC megohmmeter or tested per AREMA standards.

3.4.22 Rail Lubrication

Rail/wheel flange lubricators shall be required at locations susceptible to accelerated rail wear or generation of high noise levels (i.e. sharp curves) as identified by the project's environmental clearance process. Lubricants to be used shall be non-contaminating/environmentally neutral. Placement of rail lubricators shall be determined in part by radius of curve and delta angle through which curve extends. Placement of rail lubricators in high pedestrian traffic areas shall be avoided. It is assumed that rail lubricating devices shall not be installed on LRV's.

3.5 YARD TRACK

3.5.1 Drainage

Drainage shall conform to the requirements of Section 3.4.1.

3.5.2 Subgrade

Subgrade shall conform to the requirements of Section 3.4.2.

3.5.3 Sub-Ballast

Sub-ballast shall conform to the requirements of Section 3.4.3 above, except only a 6 in layer will be required for yard tracks.

3.5.4 Ballast

No. 5 ballast conforming to AREMA specifications shall be used in yard tracks.

A minimum depth of 8 inches of ballast shall be used between the bottom of tie and top of sub-ballast. The top of ballast elevation shall be approximately 1 inch below the top of tie and the ballast shoulder shall extend level beyond the ends of the ties to form a suitable walking surface.

Crushed slag ballast will not be permitted.

3.5.5 Cross Ties

Yard tracks shall use timber cross ties 8 ft in length spaced 26" inches center to center, except at braced and guarded track, where spacing shall be 24 inches. All cross ties shall be 6" x 8" conforming to AREMA specifications for No. 1 Grade. Switch ties shall be of various lengths as required for a No. 5 AREMA turnout with 11'-0" straight switch points.

Concrete crossties may be used in the yard as an alternate to timber ties. Comply with the requirements of Sections 3.4.5, 3.4.8 and other related Sections.

3.5.6 Rail

Yard and secondary tracks shall use new 115 RE continuously welded rail in conformance with Section 3.4.6 above. Relay rails in good condition may be used with Metropolitan Council approval.

3.5.7 Restraining and Emergency Guard Rails

Yard lead and loop tracks with a centerline radius of 300 ft or less shall have restraining rail mounted adjacent to the inside rail.

Emergency guard rail shall be installed on tracks adjacent to all major structures that may cause extensive damage to a car in the event of a derailment.

3.5.8 Rail Fastenings

Rail shall be secured to the cross ties by use of 13 inch, 8-hole tie plates with a 1:40 cant and cut spikes. Anchor spiking shall be accomplished on tangent and curved track with cut spikes in accordance with the Directive Track drawings. Drive-on rail anchors shall be used.

Rail fastenings shall conform to the requirements of Section 3.4.8 above.

3.5.9 Rail Welds

Rail ends and special track work connections shall be field-welded together according to current AREMA specifications.

3.5.10 Bolted Rail Joints

Bolted rail joints shall not be used except in locations where absolutely necessary and only with approval from the Metropolitan Council. When approved for use; rail joints shall conform to the requirements of Section 3.4.10. For relay rail, new 24 inch four hole bars may be used in the yard.

3.5.11 Special Trackwork

Special trackwork shall conform to the requirements of Section 3.4.12.

All yard turnouts shall be AREMA No. 5, with 11'-0" straight switch points conforming to AREMA Point detail 5100 with graduated risers. Bolted rigid frogs shall be used.

The operating speed through the turnouts shall be as indicated in Figure 3-8.

3.5.12 Grade Crossings

Grade crossings shall conform to the requirements of Section 3.4.15.

3.5.13 Crosswalks

Crosswalks shall conform to the requirements of Section 3.4.16. In the yard, they may be located on curves and may consist of bituminous pavement.

3.5.14 Track Bumping Posts

Track bumping posts shall conform to the requirements of Section 3.4.18.

3.5.15 Rail Lubrication

Wayside rail lubricators shall be provided per the requirements of Section 3.4.22.

TYPE OF TRACK	(1) GAUGE VARIATION	(1) CROSS LEVEL AND SUPERELEVATION VARIATION	VERTICAL TRACK ALIGNMENT		HORIZONTAL TRACK ALIGNMENT	
			TOTAL (2) DEVIATION	MIDDLE ORDINATE IN 62' CHORD	TOTAL (2) DEVIATION	MIDDLE ORDINATE IN 62' CHORD
MAIN LINE	± 1/8"	± 1/8"	± 1/2" Open	± 1/8"	± 1/2"	± 1/8"
			± 1/8" Embedded and DF			
YARD	+ 1/4" - 1/8"	± 1/4"	± 1"	± 1/4"	± 1/2"	± 1/8"

NOTES:

- (1) VARIATIONS OF GAUGE, CROSSLEVEL AND SUPERELEVATION SHALL NOT EXCEED 1/8 INCH PER 31 FEET OF TRACK.
- (2) TOTAL DEVIATION IS MEASURED BETWEEN THE THEORETICAL AND ACTUAL ALIGNMENTS AT ANY POINT IN THE TRACK, TOTAL DEVIATION IN STATION AREA 1/4 INCH.

CENTRAL CORRIDOR LRT

FIGURE 3-1

DESIGN CRITERIA

TRACK CONSTRUCTION AND MAINTENANCE TOLERANCES

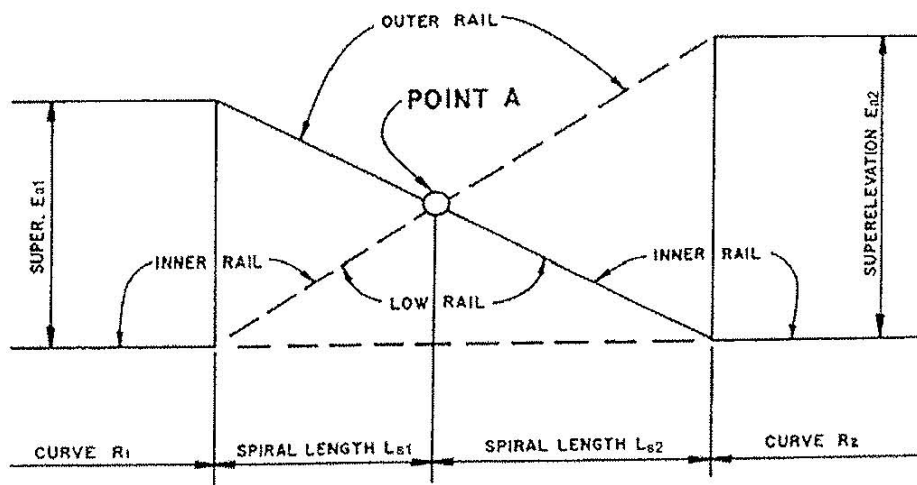

NOTE: ON SUPERELEVATED CURVE, TOP OF RAIL ELEVATIONS SHOWN ON PROFILE ARE FOR THE LOWER RAIL.

CENTRAL CORRIDOR LRT

FIGURE 3-2

DESIGN CRITERIA

**SUPERELEVATION TRANSITIONS
FOR REVERSE CURVES**

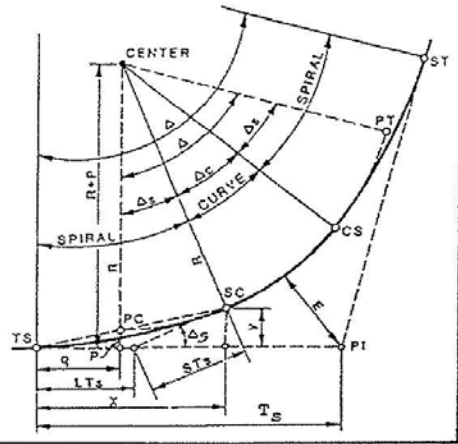

- R = radius
- D = degree of curvature
- P = offset of the PC/PT of simple curve, measured from main tangent of spiral
- q = distance from TS/ST to the PC/PT of simple curve, measured along main tangent of spiral
- X = distance from TS/ST to the SC/CS, measured along main tangent of spiral
- y = offset of SC/CS, measured from main tangent of spiral
- E = external distance
- L_s = length of spiral arc
(limiting value of l)
- l = length of spiral arc from Δ_s to any point on spiral
- LT_s = long tangent of spiral
- ST_s = short tangent of spiral
- T_s = total tangent distance TS/ST to PI
- Δ = total central angle
- Δ_s = total spiral central angle
- Δ_c = simple curve central angle
- i = deflection at Δ_s from tangent to any spiral point

$$\Delta = \Delta_c + 2\Delta_s$$

$$\Delta_s = \frac{DL_s}{200}$$

$$i = \frac{\Delta_s}{3}$$

$$s = \frac{Dl^2}{200L_s}$$

$$X = l \cos i$$

$$y = \frac{D(\text{rad})l^2}{600}$$

$$q = X - R \sin \Delta_s$$

$$P = y - R \text{ vers } \Delta_s$$

$$(\text{vers } \Delta_s = 1 - \cos \Delta_s)$$

$$T_s = (R + P) \tan \frac{\Delta}{2} + q$$

$$E = (R + P) \text{ ex sec } \frac{\Delta}{2} + P$$

$$LT_s = X - (y/\tan \Delta_s)$$

$$ST_s = y / \sin \Delta_s$$

$$T_c = R \tan \frac{\Delta_c}{2}$$

$$L_c = \frac{100 \Delta_c}{D}$$

CENTRAL CORRIDOR LRT

FIGURE 3-3

DESIGN CRITERIA

**CURVE & SPIRAL
NOMENCLATURE**



CREST TYPE VERTICAL CURVES



SAG TYPE VERTICAL CURVES

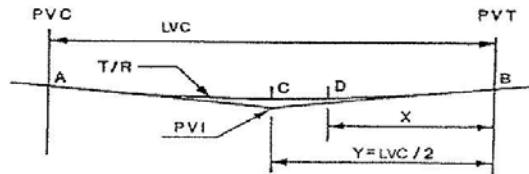

$$\text{ELEV C} = \frac{2 \text{ ELEV PVI} + \text{ELEV A} + \text{ELEV B}}{4}$$

OFFSET AT C = DIFFERENCE BETWEEN ELEV C & ELEV PVI

OFFSET AT D = OFFSET AT C $(X/Y)^2$

T/R AT D = OFFSET AT D \pm GRADIENT ELEV AT D

LVC = LENGTH OF VERTICAL CURVE

STANDARD VERTICAL CURVE

CENTRAL CORRIDOR LRT

FIGURE 3-4

DESIGN CRITERIA

STANDARD VERTICAL CURVES

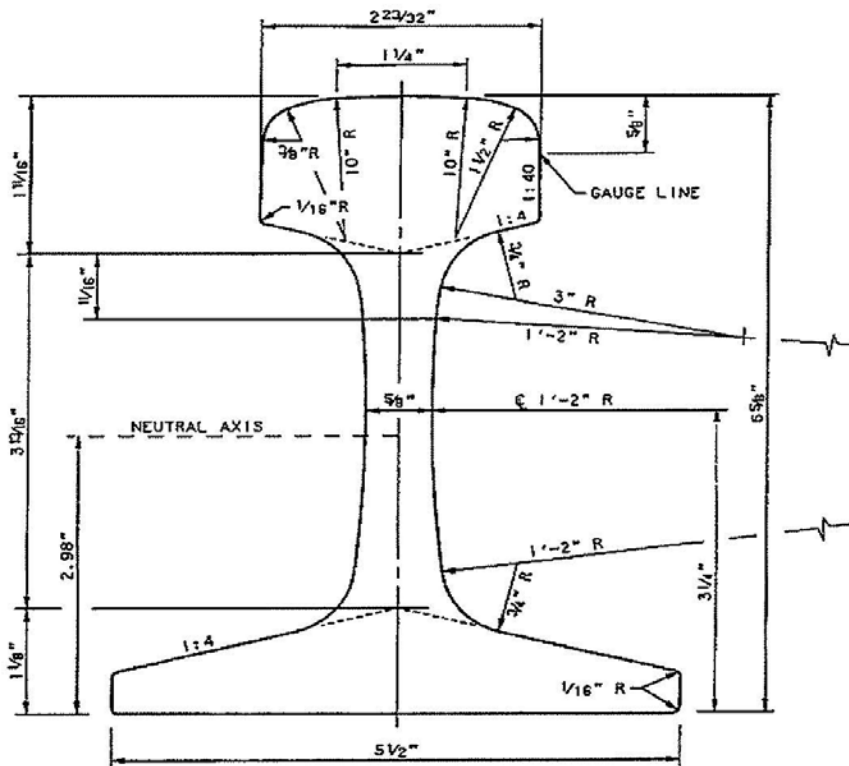

	AREA SQ. IN.	PERCENT	MOMENT OF INERTIA	65.6
HEAD	3.91	34.8	SECTION MODULUS, HEAD	18.0
WEB	3.05	27.1	SECTION MODULUS, BASE	22.0
BASE	4.29	38.1	CALCULATED WEIGHT, LB PER YD	114.7
TOTAL	11.25	100.0		

115 RE RAIL SECTION

CENTRAL CORRIDOR LRT

FIGURE 3-6

DESIGN CRITERIA

115 RE RAIL SECTION

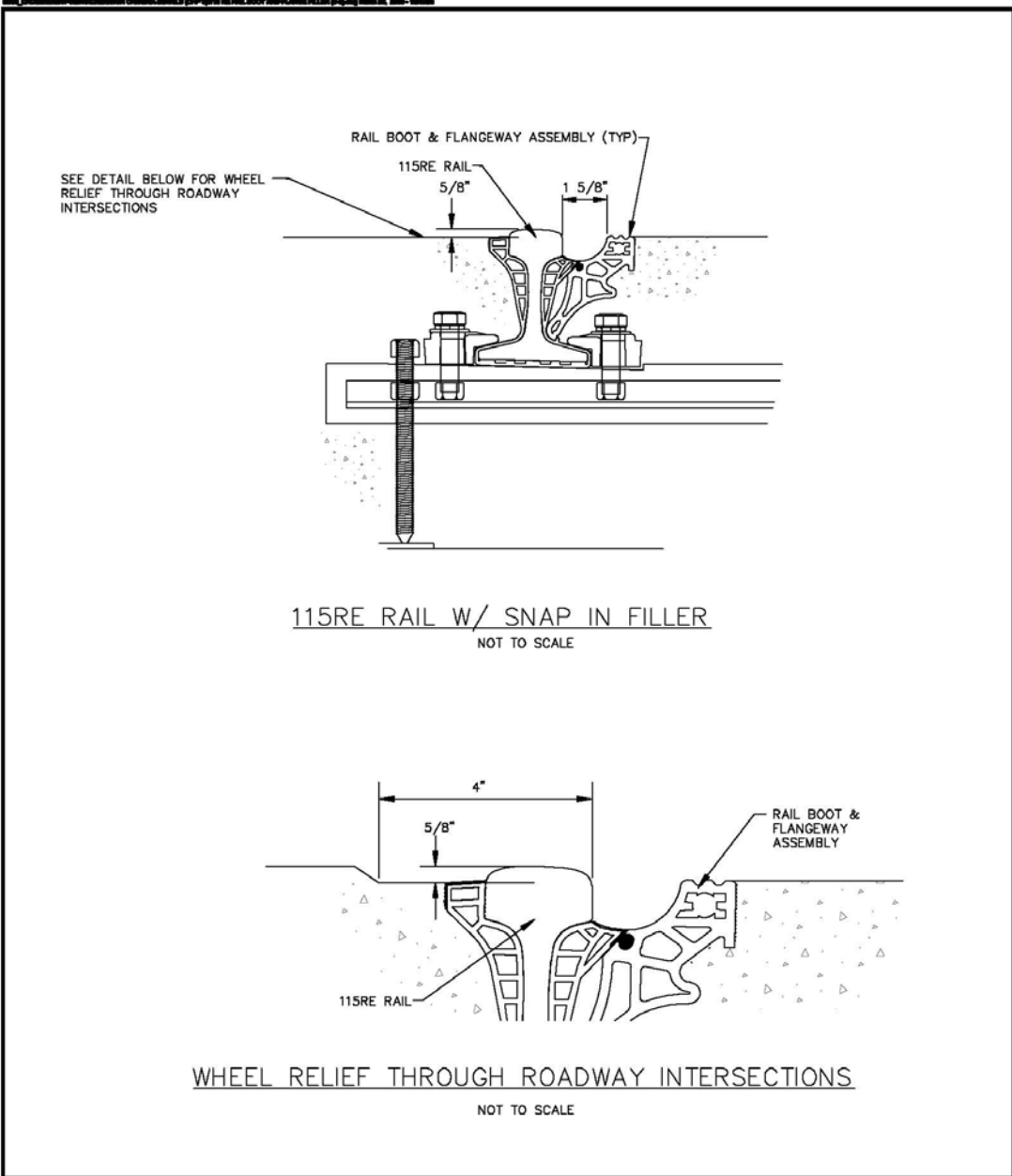

CENTRAL CORRIDOR LRT

FIGURE 3-8

DESIGN CRITERIA

115 RE RAIL BOOT AND FLANGE FILLER

TURNOUT NUMBER	MINIMUM DISTANCE FROM POINT OF SWITCH THROUGH TURNOUT TO:	
	TS OR PC	PVC
NO. 5	50'	61'
50 METER	56'	56'
NO. 6	58'	72'
NO. 8	69'	89'
NO. 10	91'	116'

CENTRAL CORRIDOR LRT

FIGURE 3-7

DESIGN CRITERIA

**LIMITING DIMENSIONS
FOR SPECIAL TRACKWORK**

TURNOUT NUMBER	SWITCH POINT LENGTH	SWITCH POINT TYPE	OPERATING SPEED - MPH (Diverging side of turnout)
NO. 5	11'-0"	STRAIGHT	12**
50 METER	15'-9"	FLEXIBLE	12**
NO. 6	13'-0"	CURVED	15
NO. 8	13'-0"	CURVED	20
NO. 10	19'-6"	CURVED	25

THE SPEED THROUGH THE STRAIGHT SIDE OF THE TURNOUT IS NOT LIMITED EXCEPT THAT IT SHOULD CONFORM TO THE SPEED DESIGNATED FOR THAT SPECIFIC SECTION OF TRACK IN WHICH IT IS LOCATED.

THESE SPEEDS ARE BASED ON AN $E_{U \text{ max}} = 3$ INCHES, ROLL ANGLE OF $2^{\circ}15'$ AND SWITCH POINT TYPES AS INDICATED.

** THE SPEED THROUGH THE ~~50 METER AND NO. 5~~ YARD TURNOUTS FOR NO. 8 TURNOUTS IN EMBEDDED TRACK, USE FLEXIBLE MANGANESE SWITCH TONGUES AND SOLID MANGANESE FROGS. (AND NO. 6 TURNOUTS)

CENTRAL CORRIDOR LRT

FIGURE 3-8

DESIGN CRITERIA

TURNOUT OPERATING SPEEDS

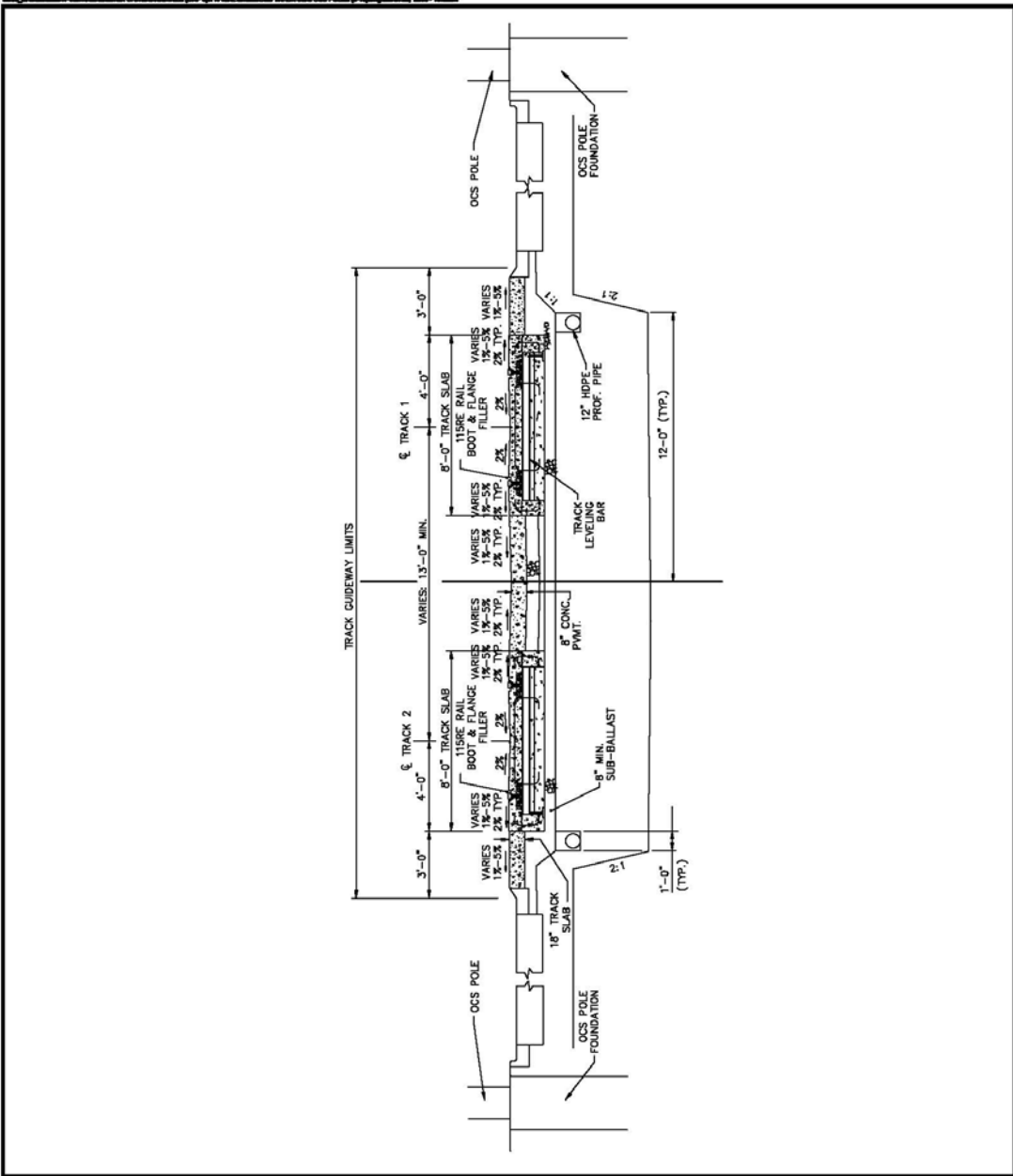

CENTRAL CORRIDOR LRT

FIGURE 3-10

DESIGN CRITERIA

TYPICAL-EMBEDDED TRACK WITH SIDE CATENARY POLES

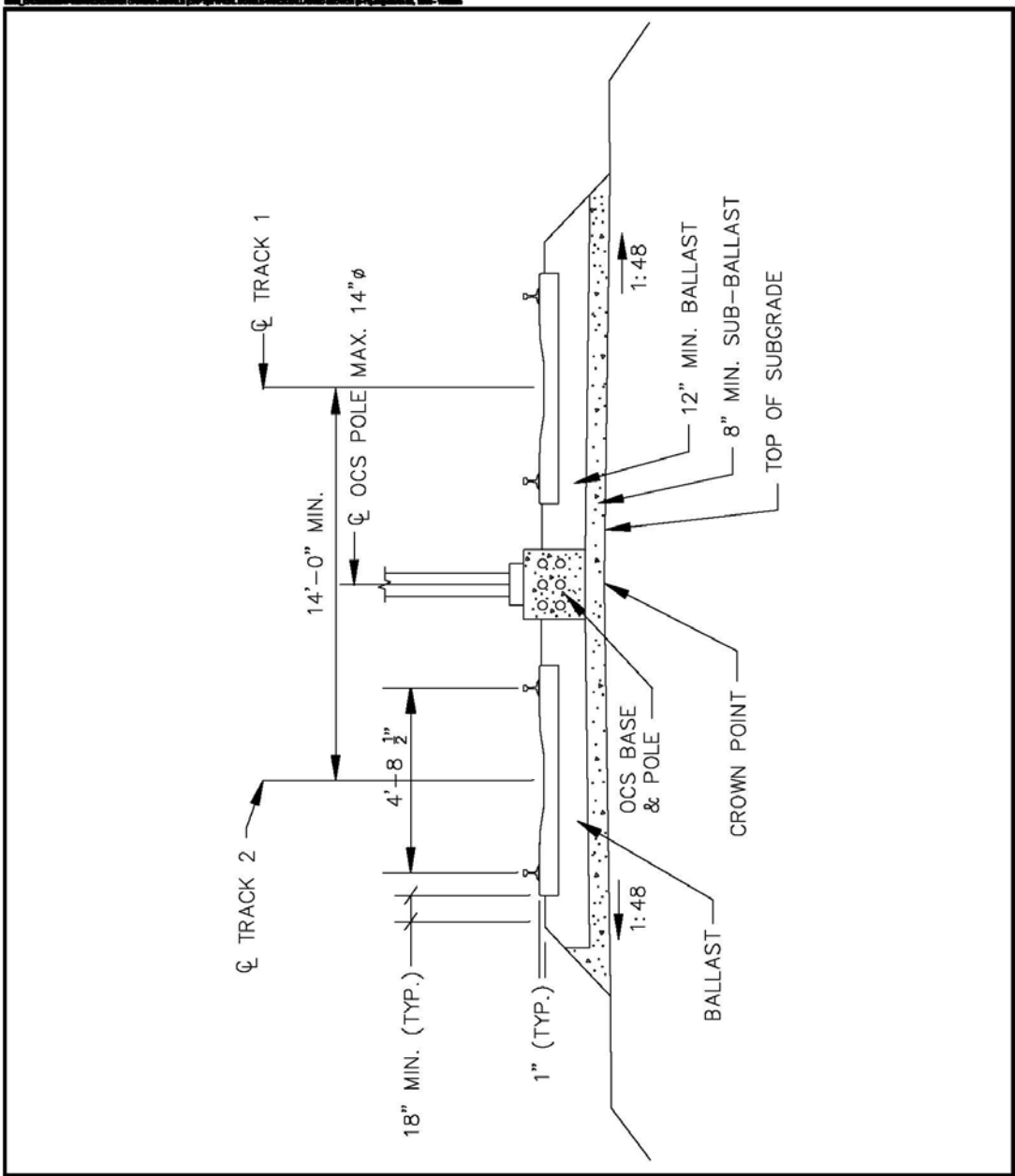

CENTRAL CORRIDOR LRT

FIGURE 3-11

DESIGN CRITERIA

**TYPICAL DOUBLE-TRACK
BALLASTED SECTION**

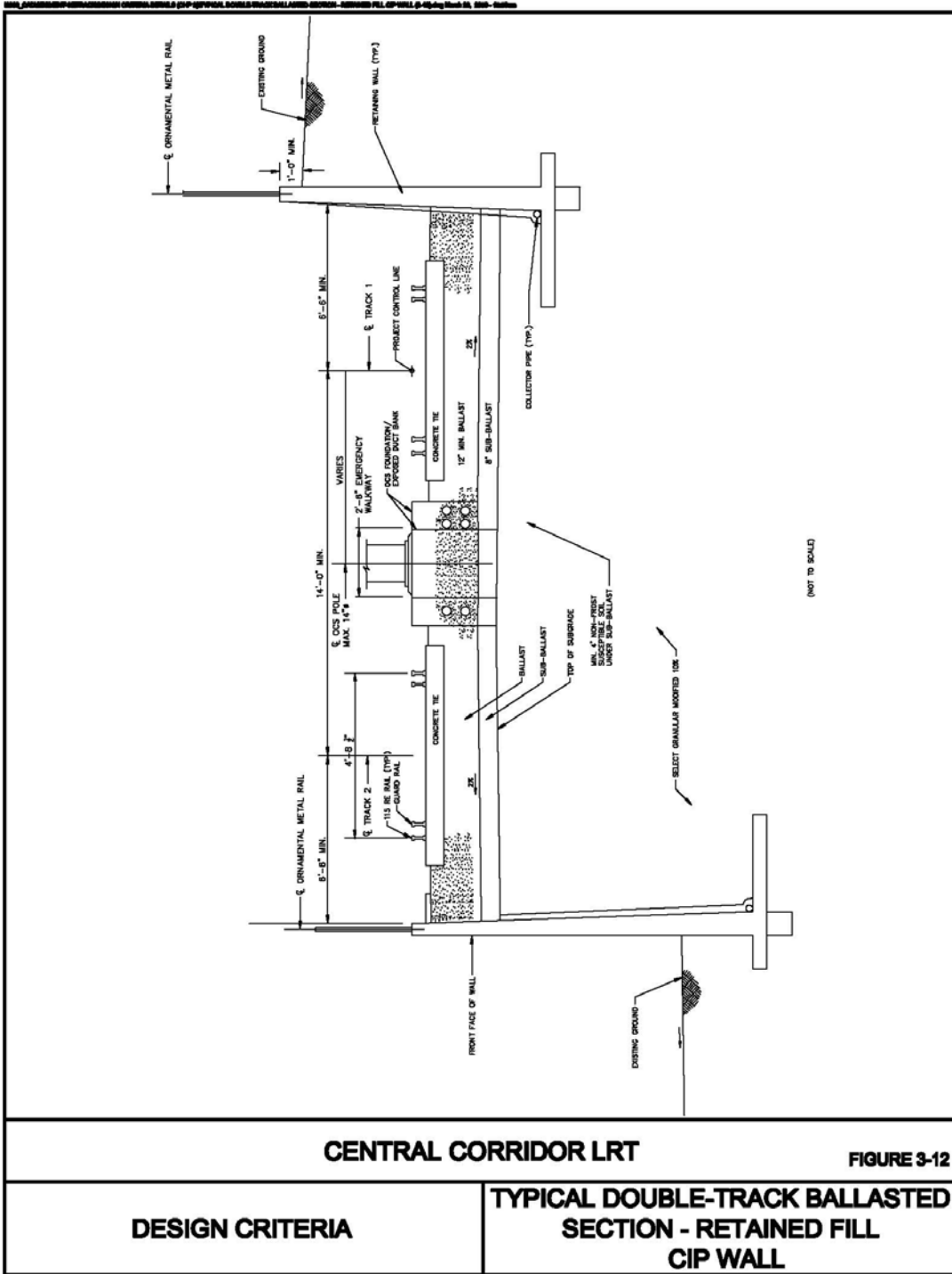

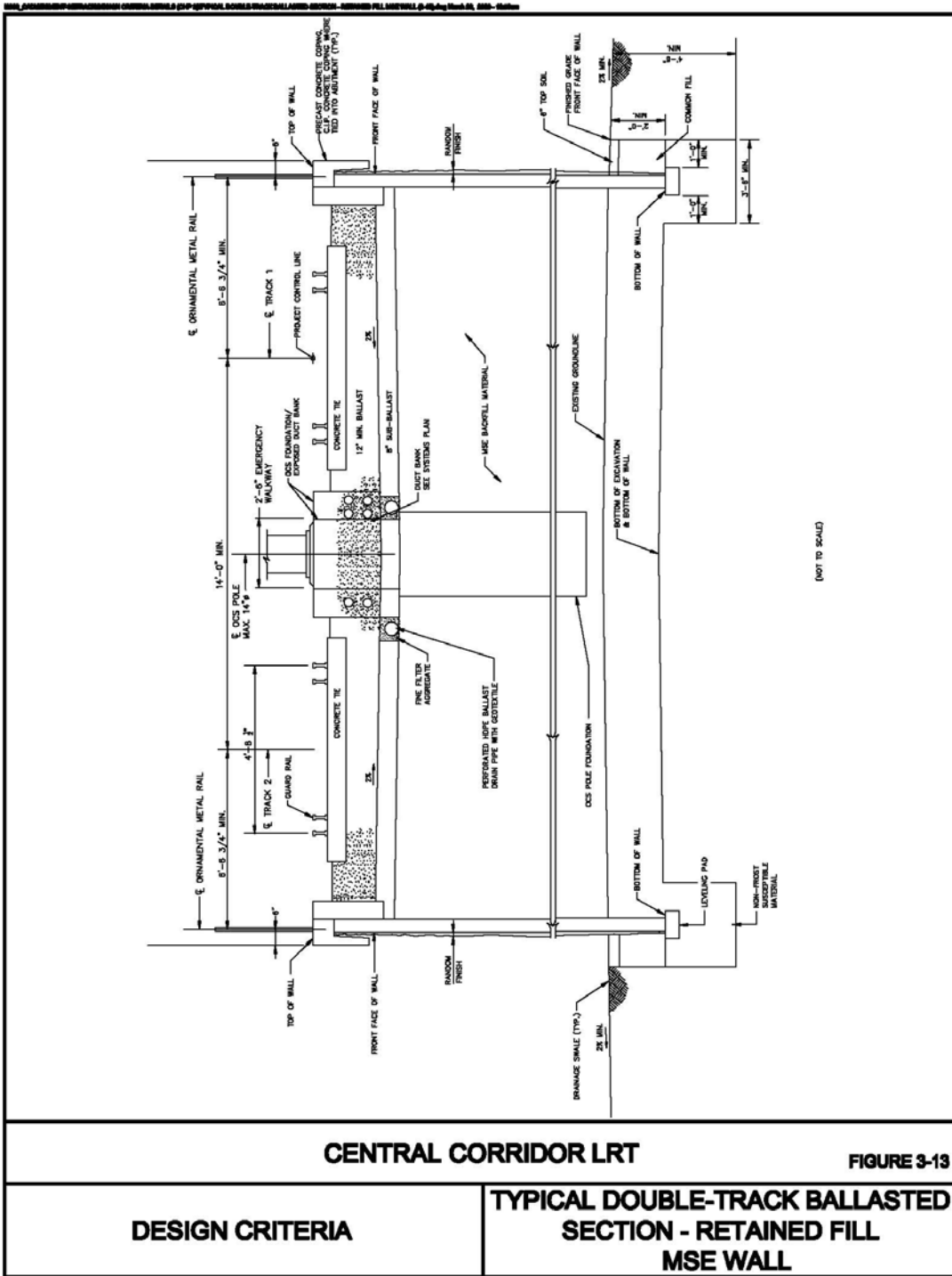

(NOT TO SCALE)

CENTRAL CORRIDOR LRT

FIGURE 3-13

DESIGN CRITERIA

TYPICAL DOUBLE-TRACK BALLASTED SECTION - RETAINED FILL MSE WALL

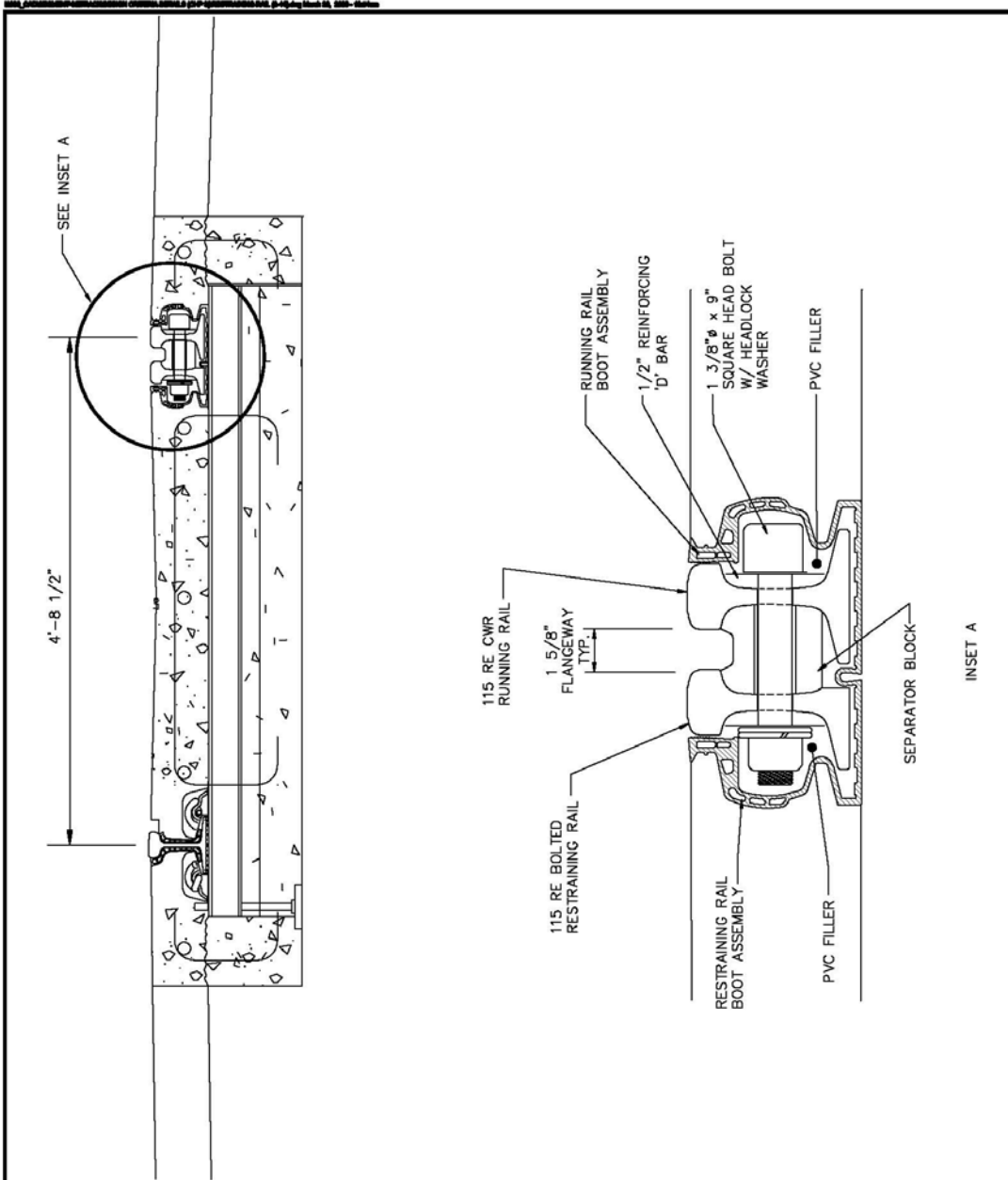

CENTRAL CORRIDOR LRT

FIGURE 3-14

DESIGN CRITERIA

**RESTRAINING RAIL
IN EMBEDDED TRACK**

4.0 UTILITIES

4.1 SCOPE

These procedures and criteria shall govern design for the relocation, adjustment, protection or other work related to existing public or private utilities, including new utilities and utility services that are required to accommodate the Central Corridor Light Rail Transit (CCLRT) System.

Due consideration shall be given to the requirements and obligations of the public and private utility owners, the service needs of adjacent properties, and the goals and objectives of the CCLRT System.

4.2 GENERAL REQUIREMENTS

4.2.1 General Design Guidelines

The following general design guidelines shall be followed for new or relocated public and private utilities. Existing utilities shall be located as required by State law and specifically those requirements of the Gopher State One-Call system and those elements of ASCE 38-02 “Standard Guideline for the Collection and Depiction of Existing Subsurface Utility Data” required by State law.

4.2.1.1 Utility Free Zone

The Utility Free Zone shall meet the definition described below for the conditions warranted. New utilities shall not be designed and constructed within the Utility Free Zone. Existing utilities within the Utility Free Zone shall be relocated outside the Utility Free Zone, unless otherwise approved by Metro Transit.

Existing utilities permitted to remain within the Utility Free Zone shall be accommodated using one of the following techniques:

- Protected and maintained in place and in operation during construction;
- Temporarily relocated and maintained in operation, then returned or replaced at its original location upon completion of LRT construction; or
- Permanently relocated to a new location beyond the limits of LRT construction.

4.2.1.1.1 Ballasted Track Section

In a Ballasted Track Section, the Utility Free Zone shall be defined as the area bounded by lines 3.0 feet below the top of rail and 10.0 feet either side of the two track centerlines (see Figure 4-1).

4.2.1.1.2 Embedded Track Section

In an Embedded Track Section, the Utility Free Zone shall be defined as the area bounded by lines 2.5 feet below the top of rail and 5.0 feet either side of the two track centerlines (see Figure 4-2).

4.2.1.2 Utility Review Zone

The Utility Review Zone shall meet the definition described below for the conditions warranted. New utilities shall not be designed and constructed within the Utility Review Zone, unless otherwise approved by Metro Transit. Existing utilities within the Utility Review Zone should be relocated outside the Utility Review Zone subject to the Utility Owner's discretion, except as described in Section 4.2.1.2.3. Utilities susceptible to the effects of stray current shall be relocated outside the Utility Review Zone, unless otherwise approved by the Utility Owner and Metro Transit.

Existing utilities permitted to remain within the Utility Review Zone shall be accommodated using one of the following techniques:

- Protected and maintained in place and in operation during construction;
- Temporarily relocated and maintained in operation, then returned or replaced at its original location upon completion of LRT construction; or
- Permanently relocated to a new location beyond the limits of LRT construction.

4.2.1.2.1 Ballasted Track Section

In a Ballasted Track Section, the Utility Review Zone shall be defined as the area bounded by lines 5.5 feet below the top of rail and 10.0 feet either side of the two track centerlines except the utility free zones describes in Section 4.2.1.1.1 (see Figure 4-1).

4.2.1.2.2 Embedded Track Section

In an Embedded Track Section, the Utility Review Zone shall be defined as the area bounded by lines 5.5 feet below the top of rail and 10.0 feet either side of the two track centerlines except the utility free zones describes in Section 4.2.1.1.2 (see Figure 4-2).

4.2.1.2.3 Utilities in Downtown Areas

In areas such as downtown St Paul and downtown Minneapolis, the sheer density of existing utilities within the Utility Review Zone would make relocation of all utilities which fall in the utility review and/or free zones impractical and cost-prohibitive. In such areas it is intended that wherever possible, utilities present within the Utility Review Zone shall be protected in place and not relocated from the Utility Review Zone, subject to the Utility Owner's discretion and Metro Transit's approval.

In many cases Utility Owners of communication lines may desire to not relocate their facilities that are located within the Utility Review Zone. To the extent that it is possible, the design should attempt to reflect that construction of the LRT trackwork and systems facilities not interfere with the existing utilities that remain in place.

4.2.1.3 Utility Crossings

Where possible, all utilities that cross beneath the LRT guideway should be oriented perpendicular to the LRT right-of-way.

Pipelines crossing the LRT guideway and conveying water, oil, gas, or other flammable, volatile, or pressurized substances should be installed within a larger casing pipe. Casing pipes shall be designed to withstand LRT loads, and shall be coated with a suitable material to provide cathodic protection (see Chapter 14). Casing pipes, where provided, should extend at least 20 feet from the nearest track centerline.

4.2.1.4 Other General Design Guidelines

Design shall provide for all utility services to adjacent properties to be maintained at all times.

Temporary or permanent replacements of any existing utilities shall be designed to provide service equivalent to that offered by the existing installations. No betterment shall be included in the design unless specifically approved by Metro Transit.

All new or relocated non-metallic utilities, pipes or casings, except those for gravity sewers, shall have tone wires that are terminated within the LRT right-of-way to aid in field-locating underground utilities.

All abandoned pipes located within the LRT right-of-way shall be plugged and filled to the standards of the local jurisdiction or removed.

Upon completion of temporary or permanent utility work, pavement, sidewalks and other affected elements shall be restored to provide service equivalent to the existing conditions. No betterment shall be included in the design unless specifically approved by Metro Transit.

4.2.2 Corrosion Protection

The guidelines for corrosion protection are provided in Chapter 14.

4.2.3 Public Utilities

All utilities (whether designed and/or constructed by Contractor or Public Utility Owner) that are to be newly installed, relocated or upgraded (betterments) shall be placed so as to minimize future pavement removal and traffic lane closures for service connections and/or maintenance work.

Newly installed or relocated communications utilities shall be placed in a single ductbank with manholes or access locations within traffic lanes.

Utility crossings at intersections shall be fully encased underneath pavement for a minimum of 20 feet outside the center of the nearest track.

4.2.4 Private Utilities

In general, private utilities will be responsible for relocating their own facilities in coordination with LRT construction. To the greatest extent possible this work is to be coordinated with the LRT construction project to provide for future utility access without impacting LRT operations or facilities. Private utility relocations shall be completed in accordance with the private utility standards and any provisions contained in applicable franchise agreements or other utility permits issued for the private utility.

Newly installed or relocated private utilities shall be placed in a single ductbank with manholes or access in a location agreed to by the local Roadway authority.

Utility crossings at intersections shall be fully encased underneath pavement for a minimum of 20 feet outside the center of the nearest track..

4.3 SPECIFIC REQUIREMENTS

4.3.1 Sewer Lines

4.3.1.1 Codes and Standards

All maintenance, relocation, restoration, and construction of sewer lines and appurtenances shall be in conformance with the current standards and specifications of the governing municipality.

4.3.1.2 General Design Guidelines

Service to adjacent properties shall be maintained during LRT construction by supporting in place, providing alternate temporary facilities, or diverting to other points.

Necessary replacements of existing sewer lines and appurtenances shall provide services equivalent to those of existing facilities. Where existing systems are to be modified or tied in to new facilities required by LRT construction, the existing system shall be cleaned and inspected prior to construction.

All sewer line design work shall be coordinated through Metro Transit and the Utility Owner. Necessary relocation, restoration, and construction of sewer lines and appurtenances shall be the responsibility of the Contractor, unless otherwise agreed to by Metro Transit and provided for in the project plans and specifications.

4.3.2 Water Lines

4.3.2.1 Codes and Standards

All maintenance, relocation, restoration, and construction of water lines and appurtenances shall be in conformance with the current standards and specifications of the governing municipality.

4.3.2.2 General Design Guidelines

Service to adjacent properties shall be maintained during LRT construction by supporting in place, providing alternate temporary facilities, or diverting to other points.

Necessary replacements of existing water lines and appurtenances shall provide services equivalent to those of existing facilities.

All water line design work shall be coordinated through Metro Transit, and the Utility Owner. Necessary relocation, restoration, and construction of water lines and appurtenances shall be the responsibility of the Contractor unless otherwise agreed to by Metro Transit and provided for in the project plans and specifications.

4.3.3 Gas Lines

4.3.3.1 Codes and Standards

All work related to gas lines shall be conducted in conformance with the applicable standards of the utility owner.

4.3.3.2 General Design Guidelines

Service to adjacent properties shall be maintained during LRT construction by either supporting in place, providing alternate temporary facilities, or diverting to other points.

Necessary replacements of existing gas lines shall provide services equivalent to those of existing facilities.

All gas line design work shall be coordinated through Metro Transit, and the Utility Owner. Necessary relocation, restoration, and construction of gas lines and appurtenances shall be the responsibility of the utility owner.

4.3.4 Electric Facilities

4.3.4.1 Codes and Standards

All work related to electric power transmission facilities (overhead and sub-surface) shall be in conformance with the applicable standards of the utility owner.

4.3.4.2 General Design Guidelines

Service to adjacent properties shall be maintained during LRT construction by either supporting in place, providing alternate temporary facilities, or diverting to other points.

Necessary replacements of existing electric power transmission facilities shall provide services equivalent to those of existing facilities.

All electric facility design work shall be coordinated through Metro Transit and the Utility Owner. Necessary relocation, restoration, and construction of electric power transmission facilities shall be the responsibility of the utility owner.

4.3.5 Communication Facilities

4.3.5.1 Codes and Standards

All work related to communication facilities (overhead and sub-surface) shall be in conformance with the specifications and standards of the utility owner.

4.3.5.2 General Design Guidelines

Service to adjacent properties shall be maintained during LRT construction by either supporting in place, providing alternate temporary facilities, or diverting to other points.

Necessary replacements of existing communication facilities shall provide services equivalent to those of existing facilities.

All communication facility work shall be coordinated through Metro Transit, and the Utility Owner. Necessary relocation, restoration, and construction of communication facilities shall be the responsibility of the utility owner.

4.3.6 Hot and Chilled Water Lines

4.3.6.1 Codes and Standards

All work related to hot and chilled water utility lines shall be in conformance with the specifications and standards of the utility owner.

4.3.6.2 General Design Guidelines

Service to adjacent properties shall be maintained during LRT construction by either supporting in place, providing alternate temporary facilities, or diverting to other points.

Necessary replacements of existing hot and chilled water facilities shall provide services equivalent to those of existing facilities.

All hot and chilled water facility work shall be coordinated through Metro Transit, and the Utility Owner. Necessary relocation, restoration, and construction of these facilities shall be the responsibility of the utility owner.

4.3.7 Vaults and Areaways

4.3.7.1 Codes and Standards

All remodeling, abandonment or other work involving sub-surface vaults and areaways extending from adjoining buildings into public right-of-way shall be in conformance with codes, standards, and practices of the governing municipality and the vault/areaway owner.

4.3.7.2 General Design Guidelines

All vault design work shall be coordinated through Metro Transit and the vault owner. Necessary work involving vaults shall be the responsibility of the Contractor and/or the vault owner.

At a minimum, the design of necessary vault work shall include the following details:

- On-site investigation and survey of all adjacent building basements;
- Portions of the vaults to be excavated;
- New walls required to permit continued use of those vault areas outside of construction limits;
- New walls required to accomplish abandonment of vaults;
- Work required to restore vaults, including delivery chutes and freight elevators;
- Emergency access to vaults during construction; and
- Area available for permanent occupancy upon completion of LRT construction.

4.3.8 LRT Utilities

4.3.8.1 Codes and Standards

All utilities specifically designed and constructed for the LRT system shall conform to the applicable standards, codes, and requirements for the applicable agency controlling the ROW.

4.3.8.2 General Design Guidelines

Preliminary and final design of LRT utilities shall be the responsibility of the Contractor or as determined by Metro Transit and the Utility Owner. Design approvals from the local jurisdictions and public utility agencies shall be coordinated through Metro Transit .

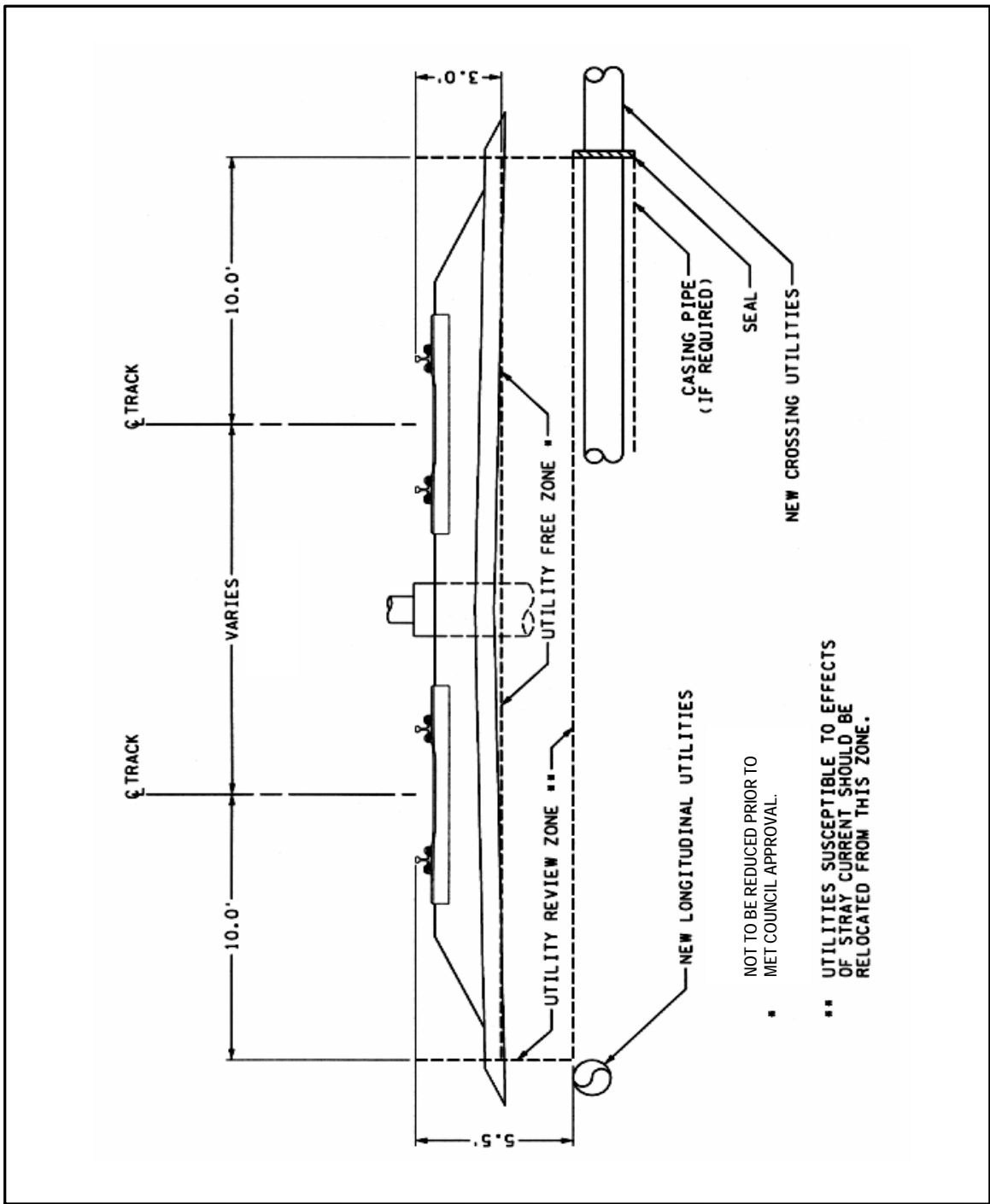

Metro Transit LRT

FIGURE 4-1

DESIGN CRITERIA

TYPICAL UTILITY LOCATIONS
BALLASTED TRACK SECTION

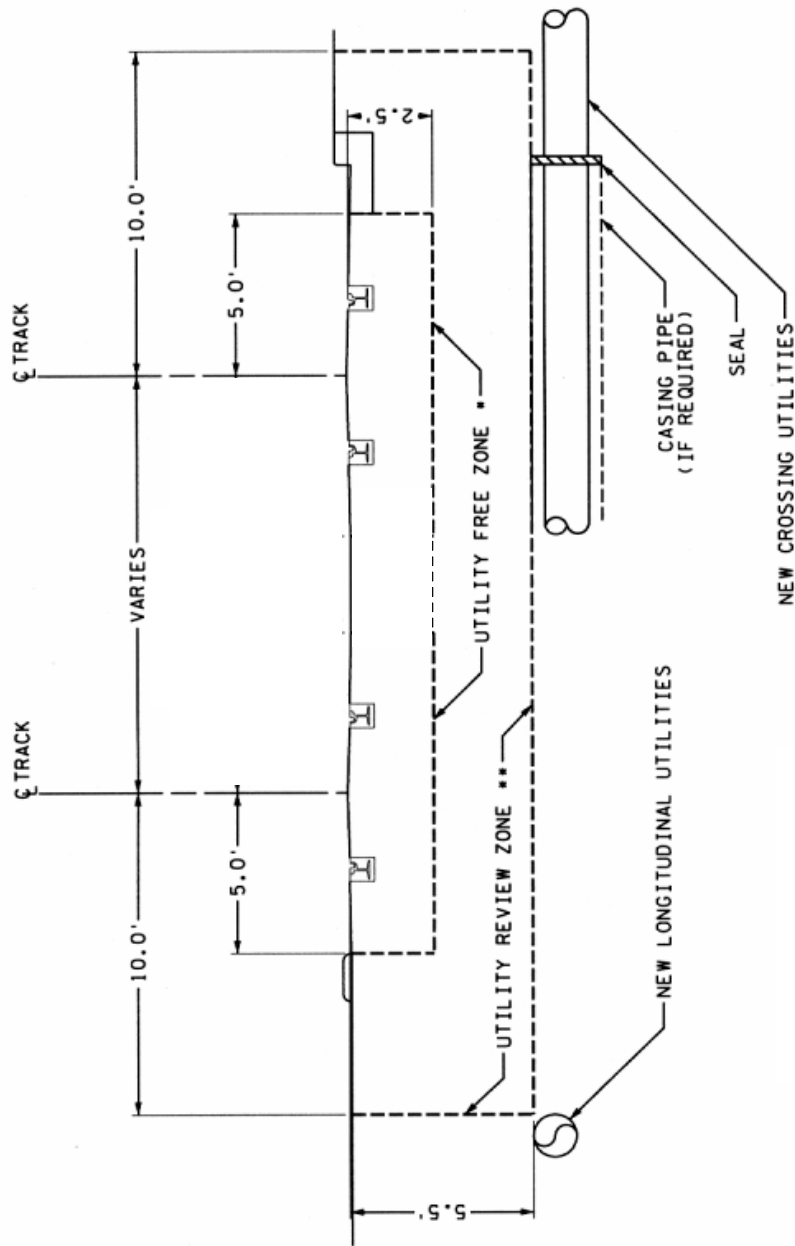

* NOT TO BE REDUCED PRIOR TO MET COUNCIL APPROVAL.

** UTILITIES SUSCEPTIBLE TO EFFECTS OF STRAY CURRENT SHOULD BE RELOCATED FROM THIS ZONE.

Metro Transit LRT

FIGURE 4-2

DESIGN CRITERIA

**TYPICAL UTILITY LOCATIONS
EMBEDDED TRACK SECTION**

5.0 LANDSCAPING & URBAN DESIGN

5.1 GENERAL

This section describes the goals and objectives and the performance requirements related to the landscape design of the station sites, platforms, yard and shop area and the trackway of the Central Corridor Light Rail Transit (CCLRT) System. The landscape designs are to be consistent with the other sections of the Criteria. Components of the landscape designs may include plant materials (trees, shrubs, groundcover, perennials, turfgrass and vines), irrigation systems, and landforms.

Central Corridor design in Saint Paul should follow principles contained within “CCLRT Design Criteria Water Quality Suggestions” and “Blooming Saint Paul” references.

5.2 OVERALL GOALS AND OBJECTIVES

- Landscape designs shall be compatible with the intended LRT operations, station architecture, and graphics;
- Landscape designs shall help to provide a safe, secure, and comfortable environment for transit patrons operators and general public;
- Landscape designs shall help to establish a cohesive visual identity for all the stations throughout the system and the trackway, as well as complement existing surroundings;
- Landscape designs shall help to reduce the impact of unattractive surroundings and to provide privacy for adjacent land uses where appropriate;
- Landscape designs shall enhance attractive views; and
- Urban Design should integrate station platform design with crosswalks and sidewalks identified in the Central Corridor Development Strategy and City of Saint Paul Area Plans.

5.3 PERFORMANCE REQUIREMENTS

5.3.1 General

- Landscape components shall comply, and design shall coordinate with local jurisdictional requirements;
- Drought, CO and salt tolerant plants and native species with ‘passive maintenance, shall be used to the maximum extent practical,
- Landscape components shall not impede proposed LRT operations or operators' views and shall not block views necessary to ensure vehicular safety;
- Landscape components shall help to control access to the station platforms and across the trackway by orienting and directing pedestrian and vehicular circulation, in conjunction with hardscape elements such as curbs and retaining walls;

-
- Landscape components shall be integrated with existing landscaping, where appropriate;
 - Landscape components, including mature plant materials, shall not obstruct visibility or views within the confines of the station sites or along the trackway, nor create areas of concealment;
 - Landscape components shall not impinge upon vehicular or pedestrian ways, nor impede circulation;
 - Landscape components shall not impede maintenance of proposed transit facilities, utilities, or existing structures;
 - Landscape components shall not be of a character that may cause injury to users or damage to facilities;
 - Landscape components shall be accessible for maintenance; and
 - Landscape components shall not interfere with installed lighting.

5.3.2 Materials

- Materials shall be of sufficient quality and substance to withstand heavy civic use.

5.3.2.1 Landforms

- Mounds and swales shall be constructed to blend in with the existing landforms and surroundings. They may be used, where appropriate, to control pedestrian movements, obscure objectionable views and reduce noise;
- Mounds shall not be higher than 6'-0" and their slopes shall not exceed 25% (1:4). Retaining walls (refer to Section 16 Civil Engineering) shall be located so as to blend adjusted slopes in excess of 25% with proposed and existing slopes and grades; and provide drainage for plant materials. They should be treated as an architectural element with consideration given to scale, color, texture, and appropriate materials to both the transit facilities and adjacent neighborhoods; and
- Mounds, steep slopes, and swales shall be covered with a groundcover, including grass, or shrubbery.

5.3.2.2 Plantings - General

- Plant materials shall conform to the requirements of the project's construction specifications related to landscaping;
- All plant materials shall conform to local codes and to the American Society of Nurserymen's standards for nursery stock and shall be nursery grown (no collected stock). In addition, the following guidelines and standards shall be referenced: Bailey's Standard Encyclopedia of Horticulture, the Mn/DOT Standard Specifications for Construction, current edition and the Inspection and Contract Administration Guidelines for Mn/DOT Landscape Projects, current edition;

-
- Plant materials shall grow well in a variety of soil and moisture conditions; be relatively free of diseases and pests; be tolerant of salt spray and salt in the soil; and produce relatively little litter;
 - Plantings within the areas encompassed by the LRT project must include material suitable for the climate and United States Department of Agriculture Hardiness Zone 4A;
 - Plant materials within the station areas shall be automatically irrigated, where appropriate;
 - Mulch shall be provided in all shrub and groundcover beds, and around individual and clustered trees;
 - Plant materials may be used in conjunction with structures (fences and walls for example) and mounds for screening; and
 - Healthy, established trees, large shrubs and shrub masses, stands of native grasses and wildflowers of appropriate species shall be preserved whenever possible.

Considerations for the selection of plant material should include the following:

- Initial cost;
- Mature height and spread;
- Growth rate;
- Seasonal form and color;
- Hardiness;
- Sun/shade preferences;
- Seed/fruit formation;
- Soil and drainage conditions;
- Tolerance to wind, pollutants, PH, and abuse (for example, salt tolerate plants are to be used near vehicular pavements);
- Transplant tolerance;
- Availability; and
- Maintenance characteristics.

5.3.2.2.1 Trees

- Trees shall be part of an existing street tree pattern, if any, or part of a street tree pattern established by the local governmental authority for adjoining areas. Where no pattern exists, an orderly pattern shall be established.
- Minimum caliper of deciduous shade trees located in paved pedestrian areas shall be 3 inches with a minimum clear-trunk height of 7'-0". Minimum caliper of deciduous trees in unpaved areas shall be 2 inches. Understory deciduous trees shall be 2 caliper inches or larger; and coniferous trees shall be 10 feet or taller.
- Whenever possible, trees shall be planted in beds (1 tree/100 cubic feet of soil mix @ 3 feet deep). Otherwise, trees may be planted with tree pits and structured soil, protected with concrete pavers in sidewalk or other paved areas.

-
- Tree species shall be approved by local agency forester to minimize effects of disease.

5.3.2.2.2 Shrubs

- Minimum shrub size shall be a 5-gallon container.

5.3.2.2.3 Groundcover and vines

- Minimum groundcover and vine size shall be a 1-gallon container;
- Groundcover may be used on slopes greater than 1:3; and
- Vines may be used selectively to landscape vertical surfaces, except masonry in conditioned buildings.

5.3.2.2.4 Turfgrass

- Turf seed mixes, as well as native prairie grasses and wildflowers, may be installed along the trackway to complement existing conditions and selectively within station areas.
- Grass shall be installed as sod and shall be maintained as a lawn within the station areas, except as noted.

5.3.2.3 Irrigation System

- Plant materials within the station areas shall be covered by an automatically controlled irrigation system. The irrigation plans shall be developed in coordination with the station area landscape and architectural plans, as well as existing surrounding conditions.
- The irrigation system shall be capable of automatic or manual operation, with the piping, valves, wires, fittings, and sprinkler heads installed below ground.
- Aboveground components, such as the control box, shall be located and installed to provide ready access for operation and maintenance, yet discourage vandalism and minimize visibility.
- The water source shall be the existing public water system (new water service connections to the existing system may be required at the stations).
- The system shall be designed to provide double coverage and to properly water various types of plant materials in zones or individually.

6.0 STATION AREA AND FACILITY REQUIREMENTS

6.1 GENERAL

This section describes the goals and objectives and performance requirements related to the design of station sites and facilities, including all circulation systems, hard surface elements, and site furnishings for the Central Corridor Light Rail Transit (CCLRT) System. They are based upon standards pertaining to vehicular and pedestrian circulation, visual aesthetics, civil and environmental engineering, and systems maintenance.

Unique site conditions and circumstances may require design adjustments. In every case, care should be taken to only incorporate changes that enhance operational efficiency and quality, to the benefit of transit patrons and operators.

6.2 OVERALL GOALS AND OBJECTIVES

- Station designs shall help to establish a readily identifiable transit system that is easy to understand and use. Elements of continuity are identified in Section 6.12.2 to promote system identity. At the same time, certain elements of the station have been identified as being variable, and potential art opportunities, to allow for a thematic design at each station in order to create a distinct character and positive image for the community.
- Station designs shall provide a safe, comfortable, and secure environment for all patrons.
- Station designs shall be aesthetically pleasing and complement the character of their surroundings. They shall be designed to take advantage of attractive, existing site features and be compatible with surrounding land uses and developmental patterns;
- Stations shall be designed to foster the enhancement of surrounding land uses and joint development.

6.3 OVERALL PERFORMANCE REQUIREMENTS

- Design requirements for the stations and facilities shall comply with the current Minnesota State Building Code and all laws, ordinances, rules, regulations and lawful orders of any public entity bearing on the performance of the work. As of December, 2007, listed below are the principal applicable fire life safety codes and standards:
 - 2007 Minnesota State Building Code including in part:
 - Chapter 1307- Elevators and Related Devices
 - Chapter 1341- Minnesota Accessibility Code
 - Chapter 4715- Minnesota Plumbing Code

And, the following codes adopted within the Minnesota State Building Code:

- 2000 International Mechanical and Fuel Gas Codes;
- 2005 National Electrical Code;

Incorporate Minnesota Sustainable Building Guidelines, Version 2.0 as appropriate for the stations and site.

Metro Transit has adopted a fire and life safety code “Light Rail Transit, Fire Life Safety Code, that is incorporated into these criteria as Section 2 and has requirements pertaining to this Section.

Comply with local jurisdictional standards and requirements.

- Station and site elements shall be durable, vandal resistant, easily maintained, and cost-effective to construct, install, and repair;
- Station and site elements shall help to control pedestrian and vehicular access to the platform and across the trackway;
- Station and site elements shall be integrated with existing landscaping, where appropriate;
- Station and site elements shall be designed and located as to enhance passive security by maintaining visibility to and within the station and station area. Avoid, or minimize, designs that create areas of concealment;
- Station and site elements shall not impede maintenance of proposed transit facilities, utilities, or existing structures.

6.4 CIRCULATION SYSTEMS

Stations may include the following circulation systems: pedestrian, bicycle, bus, automobile drop-off and pick-up, and automobile park-and-ride circulation systems. Each system will require different facilities and may serve a variety of roles depending upon the station location and program. A hierarchy shall be established for the various circulation systems that gives priority of access (including directness of route and proximity to the platforms) in the following order:

- Pedestrians;
- Bicyclists;
- Feeder Buses (Fixed Route) and shuttles;
- Taxi and Automobile drop-off and pick-up facilities, including spaces for individuals with disabilities. Parking for disabled individuals shall be located closest to the platform access points; and
- Automobile park-and-ride facilities.

6.4.1 General

- Circulation system facilities including paths, access drives, traffic lanes, automobile parking and movement and bus parking and movement areas shall be constructed according to the criteria established in Section 16: Civil Engineering.

-
- Each circulation system, including all structures and facilities, shall have a consistent system-wide, design character to provide visual and operational continuity. Site elements, including plantings and architectural components, shall be standardized and repeated whenever possible. Site layouts shall be consistent, as well;
 - Each circulation system, having unique operational requirements and characteristics, shall be designed to accommodate the operation and accessibility of other systems within and surrounding the station site;
 - Each circulation system shall be designed to discourage adverse impacts, such as noise, fumes, and traffic delays, on adjacent land uses;
 - Each circulation system shall have its own exclusive facilities and be separated from one another as much as possible. Each shall provide safe, efficient and comfortable inter-modal transfer and passage. LRT track crossings shall be avoided, when possible; and
 - Circulation system facilities including paths, access drives, and parking areas shall be constructed according to local requirements, the American Association of State Highway and Transportation Officials (AASHTO) guidelines, Mn/DOT road design manuals, and standard engineering practices.

Recommended Circulation Systems Dimensions

NOTE: Dimensions are from curb to curb

Bus Parking Area

- Single lane (one-way) 20'
- Entrance drive (two-way) 27' width
- Entrance drive (5 or more buses) 39' width
- Entrance radii @ intersection 30' min radius
- Turn-around 100' diameter
- Pullout 65' or bus length +5ft
12' deep
1:5 min. pull in taper; 1:2 min. pull out taper

Park-and-Ride Area

- Single lane (one-way) 16'
- Entrance drive (two-way) 28' width (single-lane, two-way)
40' width (single-lane, with right turn lane)
- Distribution aisles (two-way) 24' width
- Parking aisle (two-way) 24' width
- Parking space (90 degree) 9' wide x 18' to curb or as per jurisdictional guidelines
- Handicapped spaces As per Mn State Code

Drop-Off and Pick-Up Area

Entrance drive	28' width (single-lane, two-way) 40' width (single-lane, with right turn lane)
Distribution aisle	24' width
Parking aisle	24' width
(Diagonal 60 degree) parking space	9' x 20'
Curbside parking space	10' x 22'

Recommended Grades

	Longitudinal Slope			Cross Slope		
	Min.	Preferred Max.	Absolute Max.	Min.	Preferred Max.	Absolute Max.
Access road – automobiles only	1% (0.5%)*	4%	8%	0.5%	2-3%	5%
Buses and automobiles	1% (0.5%)*	3%	5%	0.5%	2-3%	5%
Approaches to access road intersection	1% (0.5%)*	3%	5%	0.5%	2-3%	5%
Parking Stalls- automobile travel lane parallel to parked vehicle	1% (0.5%)*	2%	5%	0.5%	2%	5%
ADA-accessible passenger loading			2% in any direction	----	----	----
Automobile travel lane perpendicular to parked vehicle	1% (0.5%)*	3%	5%	----	----	----
Buses	1% (0.5%)*	2%	3%	0.5%	2%	2%
Pedestrian walkways	0-1%	3%	5%	0.5%	2%	2-3%

	Longitudinal Slope			Cross Slope		
	Min.	Preferred Max.	Absolute Max.	Min.	Preferred Max.	Absolute Max.
Pedestrian ramps	----	----	8.33% with landings per Mn Code	0.5%	2%	2%
Mowed slopes	2%	33%	per geotech review	----	----	----

*Allowable minimum slopes with cross slopes of 2% or greater.

6.4.2 Pedestrian Circulation System

- Paved sidewalks and plazas, with attendant site amenities, shall be provided at each station site;
- Pedestrian paths shall connect the major off-site pedestrian origination points to the station and to the platform;
- Pedestrian paths shall connect the on-site pedestrian origination points to the platform. Origination points may include bicycle parking areas, bus stops, automobile drop-off areas, and automobile park-and-ride areas. Location and size of paths shall encourage balanced platform access and egress;
- Pedestrian paths shall be as short and direct as possible; they shall be free of obstructions, dead-ends, unnecessary turns, steps, and abrupt grade changes; and they shall allow for clear lines of sight to the platforms;
- The maximum walking distance from any parking or drop-off space to the nearest platform access point shall be 1,000 feet;
- Pedestrian paths shall be located to facilitate the safety, comfort and ease of movement for pedestrians in and around the station and station area. Avoid crossing or passing through LRT tracks, vehicular access drives, and parking areas whenever possible. Where such crossings are necessary, employ best design practices for pedestrian hazard notification and crossing design similar to concepts found in TCRP Report 17 Integration of Light Rail Transit into City Streets. Enhance refuge areas of crossings with landscape buffer and art where possible and appropriate. Refer to Section 2 Fire/Life Safety criteria for other criteria.
- LRT track crossings shall be located at least 30 feet from the end of the station platform, and railings shall be located along the access walks and ramps adjacent to the track alignment to discourage pedestrians from crossing elsewhere;
- Pedestrian paths shall be visible from on-site access drives and parking areas, as well as from adjacent streets; and

- Pedestrian paths shall be illuminated according to requirements outlined in Section 6.9.

The recommended clear width of pedestrian walkways shall be as follows:

	<u>Preferred</u>	<u>Minimum</u>
Track Crossings (pedestrian)	10 feet	8 feet
Walkways adjacent to bus stop areas	12-17 feet	6 feet
Walkways adjacent to park-and-ride facilities	----	6 feet
Walkways adjacent to drop-off and pick-up facilities	8 feet	6 feet
Crosswalks	10 feet	8 feet
Pedestrian paths	8 feet	6 feet

- Special conditions, such as near the UofM football stadium or at elevated, open cut or tunnel stations, require design for conditions uncommon to normal at-grade operations.
- Pedestrian paths, plazas, ramps, and queuing areas shall be sized in accordance with the level-of-service capacity standards contained in Pedestrian Planning and Design by J. Fruin as they relate to the projected number of patrons during peak intervals of fifteen minutes (level of service C or better). Specifically, site elements, such as fare vending facilities, and adjacent paths and plazas shall be located and sized so that queues or areas of congregation do not block pedestrian flow.

6.4.3 Vehicular Entrances and Exits

- The location of entrances and exits at each station site shall be based upon projected traffic volumes, physical site conditions, land availability, the functional classification of adjacent roadways, and the location of traffic signals;
- Direct access to and from freeways and major arterial street sites shall be avoided, if possible. Alternately, minor arterials and collector streets shall be utilized;
- Direct access to and from local residential streets shall be avoided, if possible;
- Entrance roadways shall be designed to contain sufficient traffic storage capacity to meet expected transit patronage at peak times and to prevent queues from extending onto public streets;
- Access to and from the station site onto more than one street is preferred; and
- The desirable minimum distance between any access roadway and the closest LRT track shall be based upon Mn/DOT and local jurisdictional road design guidelines.

6.4.4 Bicycle Circulation System

- Bicyclists shall be discouraged from sharing the paved sidewalks, plazas, and roadways by providing bike paths where possible; Apply appropriate Minnesota “Share the Road” principals for bicylists and motorists.
- Bicycle storage facilities of some type shall be provided at each station where there is adequate space. They shall be readily visible from the platforms, adjacent vehicular circulation areas, and pedestrian paths;
- Bicycle storage facilities shall be illuminated according to requirements specified in Section 6.9.

6.4.5 Bus Circulation System

- Bus layover and transfer facilities include bus access drives and off-street parking areas or on-street bus stops and pull-outs, as well as adjacent sidewalks and waiting areas for passengers and appropriate site amenities, such as bus shelters, benches, and litter receptacles;
- Timed-transfer buses shall have designated parking bays as close to the station platforms as possible;
- If a station site exits onto a two-way roadway, it shall have separate left-turn and right-turn exit lanes;
- Bus shelters shall be provided at a minimum ratio of one shelter per two bus bays.
- The minimum distance between any access drive entrance and other entrances or streets shall be 150 feet, whenever possible;
- Site entrances shall be located opposite existing streets and driveways, or they shall be offset at least 150 feet, whenever possible; and
- Bus parking and waiting areas shall be illuminated according to requirements outlined in Section 6.9.
- Locate bus stops as close to station entrances as feasible.

6.4.6 Automobile Circulation System

- Automobile transfer and parking facilities include automobile access drives, off-street, drop-off and pick-up areas, and park-and-ride areas, as well as waiting areas for passengers and appropriate site amenities, such as benches and litter receptacles.

6.4.6.1 Drop-Off and Pick-Up Facilities

- Vehicular circulation in the drop-off and pick-up areas shall be one-way, whenever possible, and traffic shall be allowed to re-circulate (return to the drop-off and pick-up area) within the station site;
- The location and orientation of the drop-off and pick-up areas should allow waiting drivers to clearly see the station platforms; and
- Drop-off and pick-up areas shall be illuminated in accordance with the requirements specified in Section 6.9.

6.4.6.2 Park-and-Ride Facilities

- The vehicular circulation systems within park-and-ride lots shall be designed to provide the clearest and most direct travel paths from the lot entrances to the parking spaces. In most cases this will mean that the parking facilities need to be organized into entrance drives, distribution aisles, and parking aisles;
- The entrance drives shall sort out traffic at the access points to the station sites and shall be free of any parking spaces, or connections to parking aisles;
- The distribution aisles shall channel traffic to the parking aisles and shall be free of any parking spaces;
- The parking aisles shall provide access to the parking spaces;
- The parking spaces for individuals with disabilities shall be located nearest the station platform entrance points and shall avoid crossing vehicular aisles if possible;
- The park-and-ride lots shall be designed to provide the most direct walking paths from the parking spaces to the station platforms. In most cases this will mean that the aisles are laid out perpendicularly to the station platforms so that individuals walking to the platforms can walk down the drive aisles which should lead directly to the station platforms;
- All interior parking rows shall be defined at their ends with landscaped islands, bounded by concrete curbs and gutter;
- Park-and-ride areas with more than 200 spaces shall have at least two entrances, whenever possible;
- At least one parking space shall be provided for operations and maintenance personnel near the platform except when a station is located within a street right-of-way; and
- Park-and-ride areas shall be illuminated in accordance with the requirements of Section 6.9;

6.5 HARD SURFACE ELEMENTS

This section describes the paving or hard surface treatments for the station sites. Paving associated with the station platforms is described elsewhere.

6.5.1 Automobile and Bus Area Pavement

- All vehicular driving surfaces shall include a concrete curb and gutter;
- The bus driveways and bus bays shall be concrete pavement, designed to bus axle loading standards and bus turning criteria;
- All automobile driveways and parking areas shall be bituminous pavement;
- The access driveways at the electrical substations shall be concrete pavement;
- All crosswalk and driveway and parking area surface striping and markings shall be as shown on the station site plans; and
- Provision shall be made for on-site storage of snow accumulations.

6.5.2 Sidewalk Pavement

- Sidewalks within the site shall be pre-cast concrete pavers, uncolored cast-in-place concrete, integrally colored cast-in-place concrete or other durable, low maintenance product. Surface applied color is not allowed. The surface treatment of sidewalks shall be slip resistant.
- Provision shall be made for the on-site storage of snow accumulations.
- Trees planted within the sidewalk pavement shall be installed with tree pits and structured soils.

6.6 SITE FURNISHINGS

Furnishings for station sites include all the above-ground elements which are required for station operations and security.

6.6.1 General

- Site furnishings shall complement the overall design of the station sites;
- Site furnishings shall utilize durable, easy to maintain materials, finishes, and construction methods;
- Site furnishings shall provide continuity and image consistency. Refer to Section 6.12.2 below;
- Site furnishings shall not obstruct views or create areas of concealment; and
- In addition to state and local codes, site furnishings shall comply with U.S. Homeland Security requirements for placement and design of elements within public spaces.

6.6.2 Station Platform Canopies

See Section 6.12 for canopy requirements.

6.6.3 Kiosks

- All stations shall have at least one free standing or integrated information kiosk;
- The kiosks shall be located near the station platform access points without impeding pedestrian flow to and from the platform(s). Provide adequate space surrounding the kiosks for queuing and pedestrian movement;
- Each kiosk shall include display space for station area maps, bus and LRT system maps, and transit-related information;
- Provide Metro Transit standard emergency telephone at the kiosk, or other location as approved by Metro Transit security.
- Kiosk design shall be such that one maintenance employee can change out the information alone, in harsh conditions.

-
- The kiosks shall serve as marquees for the stations and shall have internally illuminated panels displaying the station names; and
 - Kiosks shall architecturally complement the LRT platform and canopy.

6.6.4 Bus Passenger Waiting Shelters

- The bus shelters shall provide a minimum of five square feet per person during peak period use. They shall be designed to allow visual surveillance and have vertical wind and rain screens, minimum three sides; and
- Each shelter shall feature patron-activated, overhead radiant heaters.

6.6.5 Service Buildings

- Service buildings shall include a custodial room, a trash facility and an operations personnel room. Toilets may be included at selected locations; and
- Service buildings shall be located based on requirements established in the final operations plan. They may be located at stations where space permits, or in separate facilities. The location shall not interfere with station operations, but must be readily accessible to service vehicles.

6.6.5.1 Operators' Restrooms

- Where provided, Operators' toilet rooms shall provide one urinal and one toilet in the men's restroom; the women's toilet room shall have two toilets;
- Use durable, easily maintained materials on all surfaces of the toilet rooms.
- The restrooms shall be designed to meet all building and health codes; and
- The restrooms shall be constructed with the intent to provide service for bus and LRT operations personnel only and unavailable to the public.
- A Metro Transit approved electronic door locking system shall be provided.

6.6.5.2 Custodial Facility

- Room shall be a minimum of 6' x 6';
- Room shall have a keyed access door; and
- Equipment shall include one mop sink with cold and hot water, one hose bib, and a floor drain.

6.6.5.3 Operations Personnel Rooms

- Room shall be a minimum of 12' x 12', and shall be insulated and heated; and
- External glazing shall be reflective.

6.6.6 Railings

- Railings for station sites shall be designed for easy maintenance and repair;
- The railing fastening system shall be designed to allow easy repair and replacement.

6.6.7 Bicycle Storage

- Bicycle storage facilities shall be designed and located to provide a secure, sturdy and convenient system for locking up bicycles.
- The number of bicycle storage facilities shall vary by station, according to anticipated ridership and spatial constraints.
- Surfaces and materials shall be consistent with existing Metro Transit lockers.

6.6.8 Benches and Leaning Rails

- Benches and leaning rails shall be provided on the platforms, in the bus shelters, and near bus parking areas;
- Benches and leaning rails for station sites shall be specified and designed for easy maintenance and repair; and
- Benches over four feet long shall have arm rests or other impediments to discourage laying on benches. Provide back support where leaning back beyond the bench would be hazardous to the user.

6.6.9 Litter Receptacles

- Litter receptacles shall comply with U.S. Homeland Security requirements for placement and design of receptacles within public spaces.
- Receptacles for station sites shall be metal with a factory-applied, powder-coat finish, concrete, or stone and shall be designed for easy maintenance and repair;
- Receptacles are to be located at minimum 100 foot intervals along sidewalks and plazas adjacent to bus parking areas and curbside drop-off and ride facilities and on station platforms, with a minimum of 2 per station; and
- All components of the litter receptacles shall be permanently attached or locked to minimize vandalism. Receptacles shall have removable metal liners.

6.6.10 Newspaper Vending Boxes

- All station sites shall have specially designated areas, clear of circulation and queuing, for installing newspaper vending boxes. Boxes shall not be allowed elsewhere on site, including the station platforms.

-
- The newspaper vending box area shall include a system or structure for securing the newspaper vending boxes and for grouping them in one location.

6.6.11 Security Equipment

- CCTV cameras shall be provided at each station site (refer to Section 13). ;
- Coverage shall be primarily confined to station platform areas, with special attention paid to the fare vending facilities and off-platform kiosk.
- All CCTV cameras shall be visible to the public and not readily accessible.

6.7 MECHANICAL SYSTEMS

6.7.1 Water Service

- Two hose bibs, maximum 200' apart, shall be provided at each platform. Fitting shall be a quick-coupler valve in a lockable, flush-mounted box.
- Water shall be provided at all stations in minimum 1" diameter pipe.
- Hot and cold water shall be supplied to all restrooms and custodial rooms.
- Provide irrigation to any planted areas within the station platform area.

6.7.2 Heating and Ventilation

- Service buildings shall be insulated and heated with thermostatically-controlled, electronic heaters to maintain a minimum temperature of 65 degrees.
- Service buildings shall be ventilated to ensure that temperature remains below 104° F and will discharge a minimum 2 CFM/square foot of air.

6.8 SITE SIGNS AND GRAPHICS

6.8.1 General

- Signs and graphics shall be designed to clarify site and systems usage; that is, to guide patrons through the station site in the least complicated manner and to maintain patron orientation at all times, during regular operations and in emergencies;
- Signs and graphics shall comply with the Overall Goals and Objectives (refer to 6.2), ADA and AASHTO requirements, the standards described in the Minnesota Manual on Uniform Traffic Control Devices, and local jurisdictional requirements;
- Signs and graphics shall offer transit patrons uniform (system-wide) and easily understood directions, warnings, and information;
- Signs and graphics elements (materials and finishes) shall visually complement one another and the architectural design of the station;
- Signs and graphics shall employ or complement existing national and international standard designs; and

-
- Signs and graphics shall assist persons with disabilities, non-English speakers, and non-readers in the use of the LRT facilities.

6.8.2 System-wide Components

- One externally-illuminated entry sign shall be provided at each vehicular entrance to station site;
- One internally-illuminated bus bay sign shall be located adjacent to each bus bay;
- At least one internally-illuminated identification sign shall be located on each station platform canopy;
- At least one variable message sign shall be located on each station platform;
- Non-illuminated, free-standing or integrated, blade signs are to be provided as required; and
- Traffic-control signs, pavement markings, and signals are to be provided as required in Section 17, Traffic Engineering.

6.9 LIGHTING

6.9.1 General

- The design shall provide lighting that is properly selected and located to achieve the required illumination levels in each facility area for safe, reliable and continuous operation of facilities systems, as well as to promote safety and comfort for all transit patrons and LRT system employees;
- Lighting shall be consistent with the Overall Goals and Objectives (refer Section 6.2); Refer to Section 11 Electrical Systems for specific criteria
- Lighting components shall complement station architecture and surrounding systems
- The design shall provide system wide consistency of the various lamps selected for use at each station and site.;
- Lighting shall help to define usage areas, entrances and exits, level changes, and passageways.

6.9.2 Vehicular Circulation Lighting

- Lighting poles shall be located generally along the parking barriers, within parking islands and/or the parking lot perimeter. The placement of poles shall present a minimum obstruction to movement and parking of cars;
- Security lighting shall be provided for parking lots, and entrance and exit roadways. Security lighting may utilize the same fixtures as for normal lighting;
- Special care shall be taken to avoid "spill" light and objectionable glare which might affect adjacent properties and roadways; and
- Illumination shall be provided for vehicular traffic areas within the station boundary lines. A hierarchy of lighting levels shall provide a natural lead-in to the bus loading/unloading, auto drop-off, and parking areas. The

illumination on all access and egress roads shall be graduated up or down to the illumination of the "feeder" street or highway.

6.9.3 Pedestrian Circulation

- Pedestrian lighting shall be located along walkways and at crosswalks, stairs, ramps, and bicycle storage areas.
- Lighting of outdoor plazas, pedestrian walkways, and similar areas shall be accomplished by utilizing luminaries on low poles and bollards.

6.9.4 Emergency Lighting

- Emergency lighting shall be provided in all enclosed (indoor or underground) public facilities, electrical rooms and systems equipment rooms shall have emergency lighting.
- Emergency lighting for stairs and escalators shall be designed to emphasize illumination on the top and bottom steps and landings.
- All newel and comb lighting on escalator steps shall be on emergency power circuits
- Emergency lighting shall also be provided for the restrooms, electrical rooms, operations personnel rooms, and traction power substation.

The following spaces do not need provision for emergency lighting:

- Public spaces - drop-off areas and parking lots; and
- Non-public spaces - spaces such as custodial rooms, telephone closets, and trash rooms.

6.9.5 Exit Sign Lights

Station signs which indicate exits or routes to exits shall be provided. Such signs shall be internally illuminated and located to direct occupants to each required station exit.

6.9.6 Lighting Control Systems

The lighting system shall be controlled to effectively coincide with system operation.

The lighting system is expected to operate continuously and rely on both automatic and manual controls.

All parking lot, plaza, and walkway lighting shall be controlled automatically by photocell and time-clock switches. For security lighting, circuits shall be designed so that approximately 15 to 25 percent of normal parking area and roadway entrance lighting shall be controlled by photocells. The remainder of exterior lighting shall be controlled by photocells but may be turned off by time-clock switches.

6.9.7 Illumination Levels

Refer to Section 11: Electrical Systems for minimum station and site illumination levels.

6.10 ADVERTISING

Advertising, including community information, shall be permitted in station areas. Allow for areas of advertising to comply with the Overall Goals and Objectives for station sites (refer Section 6.02). Advertising shall occupy pre-determined locations which will be dimensioned according to advertising industry standards. In addition:

- Advertising shall not interfere with transit patron circulation, visibility of transit vehicles or LRT information systems;
- Advertising shall not be readily visible from the surrounding neighborhood; and
- Location of advertising, if included, shall be incorporated into the station design.
- Concessions will not be allowed on the platforms.

6.11 PUBLIC ART

Refer to Section 6.12.2 for station elements identified for possible art opportunities. If incorporated, a process for selection and procurement of art shall be prepared that includes input from local governments, art agencies and the public..

6.12 STATION FACILITIES

6.12.1 General

- Station facilities shall have a consistent, system-wide design maintaining functional similarity. This criterion allows certain elements of the station to respond to site-specific conditions, neighborhood concerns and owner preferences;
- Station facilities shall not impede patron circulation and ease of movement;
- Station facilities shall present an inviting physical and visual environment for patrons while ensuring the station materials, finishes and construction methods are durable and vandal-resistant;
- Station facilities shall use similar architectural and functional elements in a consistent manner to provide legibility and functional clarity. Economic, safety and operational considerations also dictate the use of repetitive elements for the basic components of the stations and a degree of standardization;
- Station facilities shall be designed and constructed to minimize maintenance and repair requirements and be cost-effective to install; and

- Station facilities shall conform to local codes as well as to the ADA requirements, and the National Fire Protection Association (NFPA).

6.12.2 Elements of Continuity and Variability

The following list identifies various station components as either an element of continuity or of variability. The distinction between the two is defined as follows:

Continuity: Components to be standardized within the system for the purposes of either station identity, functional consistency, operational characteristics and maintenance procedures.

Variability: Components designated to be consistent throughout a particular station and site but variable system-wide. Variability is an option, not a requirement. The nature of the variability is in terms of color, texture, materials, form and assembly. Limits of variability shall be within the parameters established throughout this criteria.

Art Opportunity: Of those elements that are variable, the identified items in the chart represent opportunities for artist participation.

<u>Component</u>	System-wide Continuity	Station-to-Station Variability	Art Opportunity
Information Devices:			
• Identification/ Gateway signs		X	X
• Kiosk/ information enclosure		X	X
• System signs, including variable message signs and kiosk/ information identity logo	X		
• System maps	X		
• Vicinity maps	X		
Platform Configuration:			
• Edge Detail	X		
• Edge Border		X	X
• Pavement Field Pattern		X	X
• Traffic edge/barrier condition		X	X
Canopies:			
• Form	X		
• Structural Elements	X		
• Materials/Finishes		X	

<u>Component</u>	<u>System-wide Continuity</u>	<u>Station-to-Station Variability</u>	<u>Art Opportunity</u>
<ul style="list-style-type: none"> • Column base cover • Length/Extent 		X X	X
Bus Stop Shelters:			
<ul style="list-style-type: none"> • Form • Materials/Finishes 	X X		
Windscreens:			
<ul style="list-style-type: none"> • Form • Transparent Materials/Finishes • Length/Extent 	X X	X	X
Stairs and Ramps			
<ul style="list-style-type: none"> • Materials/Finishes • Handrails • Guardrails 		X X X	X X
Leaning Rails			
<ul style="list-style-type: none"> • Materials/Finishes 	X		
Doors and Hardware			
<ul style="list-style-type: none"> • Keying • Finish 	X X		
Litter Receptacles			
<ul style="list-style-type: none"> • Materials/Finishes • Quantity 	X	X	
Bicycle Racks			
<ul style="list-style-type: none"> • Materials/Finish • Form • Quantity 	X	X X	X X
Bicycle Lockers			
<ul style="list-style-type: none"> • Materials/Finish • Quantity 	X	X	
Benches			
<ul style="list-style-type: none"> • Materials/Finish • Quantity • Form 	X	X X	X
Ancillary facilities, including service buildings and substations			
<ul style="list-style-type: none"> • Location • Materials/Finishes • Construction 		X X X	

<u>Component</u>	<u>System-wide Continuity</u>	<u>Station-to-Station Variability</u>	<u>Art Opportunity</u>
• Components	X		
Systems and Equipment			
• HVAC	X		
• Electrical	X		
• Fare vending	X		
• Communications	X		
• Emergency and safety equipment	X		
• Station control	X		
• Security equipment	X		
Light fixtures, public spaces			
• Lamp	X		
• Housing		X	
Light fixtures, non-public or emergency			
	X		
Retaining walls			
		X	X
Ceilings			
	X		
Acoustic treatment			
	X		
Landscaping			
	X		
Advertising			
• Location	X		
• Quantity		X	

6.12.3 Platform Configuration, Circulation and Clearances

6.12.3.1 Configuration

- Station platforms shall be low platforms. The platform edge shall be 1'-2" above the top of the adjacent LRT rails.
- Center platforms are to be accessed via ramps located at each end; side platforms may be accessed along their length, as well as via ramps located at each end; and elevated, open cut or tunnel platforms may be accessed at the ends or within the platform area via elevators, stairs and escalators.
- Level boarding is required for all station platforms. Cross slopes shall be a minimum 1% (1:100) and no more than 2% (1:50). The maximum longitudinal slope shall be 2%.
- The minimum length of the station platform shall be 270'-0". The basis for the platform length is a maximum three-car consist, each car being approximately 90' long.

- Nominal station platform widths are indicated below. The exact lengths and widths will depend on specific site constraints, LRT selection and final track alignment design.

Center	Side
20'	12'

- Only the platform edge is allowed to encroach into the LRT clearance envelope. Canopies, signs, etc., must be outside the envelope.

6.12.3.2 Edge Condition

- The platform edge strip shall be a system-wide standard.
- The platform edge strip shall be 2'-0" wide. It shall be a distinctly contrasting color and texture, in relation to adjacent pedestrian surfaces, and shall comply with provisions of the ADA.

6.12.3.3 Horizontal Circulation at Station Platforms and Access

- Horizontal queuing and required widths of circulation devices, fare equipment and platform edges are identified in this section. Required widths of general pedestrian circulation paths are also given. Clearances given for devices represent the distances required to approach and queue in front of that device. Minimum and preferred dimensions are shown in Table 6.12.3.3-A and Table 6.12.3.3-B.
- In determining the total distance required between two devices (and/or a circulation path or an obstruction) the dimensions should be added together, queuing areas shall not overlap. Similarly, circulation paths shall not overlap queuing areas.

**Table 6.12.3.3-A
Minimum and Preferred Width Requirements**

	<u>Pref.</u>	<u>Min.</u>
General Pedestrian circulation	10'	6'
Platform edge to obstruction	8'	6'-8"
Stairs	6'	5'-6"
Ramp	8'	6'

**Table 6.12.3.3-B
Minimum and Preferred Queuing Requirements**

<u>Pref.</u>	<u>Min.</u>
--------------	-------------

Stairs (1)	8'	6'
Ramps	8'	6'
Doors (2)	6'	4'
Ticket vending (3)	8'	6'

- (1) Distance measured from the end of the handrail extension.
- (2) Distance measured from the end of the door swing.
- (3) Ticket vending includes ticket validating.

6.12.3.4 Overhead Clearances

- In all public areas, including portals, the minimum overhead clearance shall be no less than 8'-6", with 9'-0" minimum preferred.
- Reduced clearances are allowed in some localized areas: i.e., isolated structural supports overhead elements (8'-0" preferred, 7'-0" absolute minimum).

6.12.3.5 Stairs

- Minimum stair tread width to be 5'-6" for public stairs, 4'-0" for emergency stairs.
- The maximum height between stair landings shall be 12'. The minimum landing length for straight run stairs shall be 4'-0";
- Risers shall not be open; and
- Tactile warning strips shall be included at the top and bottom risers.

6.12.3.6 Guardrails

- To discourage climbing of guardrails, intermediate horizontal rails are not allowed where the change in grade is greater than 6'-0";
- Guardrails shall be 3'-6", measured to the top; and
- Guardrails shall be located along the outer edge of any structure or sidewalk where the difference in the adjacent grade is 2'-6" or more.
- Guardrails shall be located along a platform edge adjacent to a roadway. The platform edge adjacent to the trackway is exempted from this requirement.

6.12.3.7 Platform Access Walkways

- Walkways shall be provided at the end of at-grade, center and side station platforms. Provide handrails on both sides of these walkways.
- Minimum walkway width to be 6'-0";
- Maximum slope to be 5%(1:20). Walkways over 5% are 'ramps' as defined in the MSBC

-
- All landings shall comply with the Minnesota Accessibility Code and ADA requirements;
 - The vertical rise between landings shall not exceed 30". The horizontal run shall not exceed 40'.

6.12.3.8 Elevators

- Elevators shall provide full accessibility to station platform(s), but not impede pedestrian flow or queuing;
- Each station that requires access via vertical circulation to the platform shall provide at least one elevator in addition to any other vertical circulation devices (stairs, ramps). Elevator cab equipment shall conform to ADA requirements. Elevator machine rooms shall be located as near as possible to hoistways, but clear of public platform walking and landing areas;
- Elevators shall be sized to allow a wheelchair to execute a 180° turn within the cab and accommodate a standard hospital rolling stretcher;
- Both elevator cab and hoistway enclosure shall be glazed to the maximum extent possible in order to enhance both actual and perceived security of the elevator and passengers;
- Refer to Section 11: Electrical Systems for Elevator Cab Illumination Levels; and
- Elevator cab interior finishes shall be stainless steel with composite backing, no wood is permitted. Provide diamond plate floor finishes.

6.12.3.9 Weather Protection

- Weather protection shall be provided at ticket vending areas.
- Overhead canopies shall be located to protect patrons while entering the LRV. The extent of canopies shall be based on ridership and available budget
- Transparent windscreens shall be used on the platform to provide areas of protection from prevailing winter wind directions while maintaining visual openness for security. Each windscreen enclosure shall be three-sided and extent to a roof (or canopy) no more than ten feet above the platform. Windscreen walls shall extend to the platform surface without gaps;
- Each windscreen enclosure shall have at least one patron-activated, overhead, radiant heater (refer to Chapter 11, Electrical Systems) , the bottom to be located at 8 to 9 ft above the platform surface elevation.
- Gutters and downspouts, if used, shall be easily accessible for maintenance and connect to a storm water system. Drainage shall be directed away from the platform edge and trackway. Provide heat tape for downspouts in elevated stations and as deemed necessary to prevent potential ice build up on traveled surfaces.

6.13 MATERIALS AND FINISHES

6.13.1 General

- The philosophy for the selection of architectural finishes is to target limited amounts of durable materials in key locations. Appropriate materials are those that do not need coatings or coverings, will survive constant use and abuse, and require minimum or no maintenance. Preference shall be given to readily available, standard items or materials;
- All stations shall be of noncombustible Type I or Type II construction per the Minnesota State Building Code.;
- Durable and cost-effective materials shall be used that have consistent wear, strength and weathering qualities. Materials shall be capable of good appearance throughout their useful life and shall be colorfast, or integrally-colored, as appropriate;
- Life-cycle maintenance costs shall be considered in the evaluation of all materials and finishes;
- Materials that do not soil or stain easily shall be used and shall have surfaces that are easily cleaned in a single operation. Minor soiling should not be apparent. Commonly used equipment and cleaning agents should be able to be utilized. Assume that surfaces and materials within a 9' high touch zone will be directly exposed to public contact;
- Materials shall be standardized as much as possible for easy repair or replacement without undue cost or disruption of LRT operation;
- Entrances, stairways, platforms edge strips, and areas around equipment shall have high nonslip properties. Floor finishes shall be nonslip even when wet.;
- Materials shall be compatible with the climate;
- Dense, hard, nonporous materials are preferred for all applications. Finish materials shall be corrosion, acid, and alkali resistant and shall be compatible with chemical compounds required for maintenance. All porous finishes subject to public contact shall be treated or finished in a manner that allows easy removal of graffiti; and
- All finish materials in underground spaces shall be selected and detailed with proper attention to waterproofing, drainage, and venting. All drainage cavities shall have provisions for clean-out.

6.13.2 Acceptable and Non-acceptable Materials

6.13.2.1 Floor Materials

All floors shall be finished to provide a slip-resistant surface.

- Acceptable: Monolithic materials
 - Concrete, integrally-colored or uncolored

Unit materials

- Concrete pavers
- Vinyl tile; in non-public areas only

- Non-acceptable: Monolithic materials
 - Synthetic resin toppings
 - Bituminous toppings

Unit materials

- Carpet
- Wood products

6.13.2.2 Platform Edge Strip

Use the approved Metro Transit platform edge strip and associated standard detailing.

6.13.2.3 Wall Materials

- Acceptable: Monolithic materials
 - Form-finished concrete
 - Unfinished concrete, in non-public areas only

Unit materials

- Pre-glazed concrete masonry units
- Glazed ceramic tile
- Unglazed ceramic mosaic tile
- Pre-cast concrete
- Glazed and unglazed brick
- Stainless Steel (Natural or Porcelain Finish)
- Porcelain enamel
- Stone
- Glass

- Non-acceptable: Monolithic materials
 - Gypsum board
 - Paint
 - Vinyl wall coverings (except in non-public restroom)
 - Synthetic plaster systems

Unit materials

- Plastics
- Wood

6.13.2.4 Canopy Materials

- Acceptable: Monolithic materials

-
- Form finished concrete
 - Exterior plaster

Unit materials

- Standing seam metal decking
- Translucent panels

- Non-acceptable: Monolithic materials
 - Sprayed acoustic materials
 - Gypsum board

Unit materials

- Acoustic tile
- Wood

6.13.2.5 Canopy Structural Elements

- Acceptable:
 - Pre-finished Metal
 - Pre-Cast concrete and unit masonry
- Non-acceptable:
 - Wood

6.13.2.6 Stairs

- Treads and risers: Solid granite or pre-cast concrete for all public stairs. Provide a textured warning strip at the top and bottom tread of all stairs.
- Handrails: stainless steel.

6.13.2.7 Guardrails

Steel with factory-applied, powder-coat finish, stainless steel, or wrought iron.

6.13.2.8 Windscreens

- Transparent materials: ½ inch tempered glass, same widths as Metro Transit standard bus shelters.
- Opaque materials: same as wall materials..

6.13.2.9 Benches and Leaning Rails

- Bench base: concrete, steel with factory-applied, powder-coat finish, or stone;
- Bench seat: steel with factory-applied, powder-coat finish; and
- Leaning rail: metal with factory-applied, powder-coat finish.

6.13.2.10 Lighting Fixtures

- Emergency and non-public luminaires: fluorescent; and

-
- Public area lamps: HID metal halide. Luminaire housings are a variable item.

6.13.2.11 Telephones

- Provide at least one emergency phone on or near the platform.
- No public telephones are to be provided.

6.14 CCTV

- A closed-circuit, television monitoring system shall be provided at all station platforms (refer to Section 11 and 13).

7.0 TUNNEL DESIGN

7.1 INTRODUCTION

This document sets forth the structural design criteria for the underground structures of the Central Corridor Light Rail Transit (CCLRT) Project. These design criteria apply to below grade elements of the station structures, the cut-and-cover tunnels, Open Roof Transition Structures, the portal structures, and the approach slabs.

7.1.1 Definitions

The following definitions apply:

Cut-and-cover tunnel: Externally waterproofed reinforced cast-in-place concrete structure below finish grade.

Below grade station structures: The reinforced concrete portion of the station shell below the finished grade.

Open Roof Transition Structure: Also called U-sections. These reinforced concrete transition structures without a roof slab convey the line and grade of the alignment from the ground surface to a tunnel portal; often referred to as “boat” sections, when the invert slab is located below the groundwater table.

Tunnel portal: The entrance or exit from a tunnel to an open roof transition structure.

Approach slab: A direct buried slab placed beneath the traveled way that transitions the stiffness of the ballasted track to the stiffness of the open roof transition structure.

7.1.2 Regulations, Codes, and Standards

The design of underground structures shall be in compliance with all laws and regulations; these designs shall also generally conform to the prevalent standards and governing codes.

7.1.2.1 State and Local Laws

The structural design shall meet all applicable portions of the general laws and regulations of the State of Minnesota as well as the respective local authorities.

7.1.2.2 Basis of Design Criteria

Unless noted, or directed otherwise, the design of structures shall generally conform to the prevalent standards, codes and guidelines as listed below.

- American Association of State Highway and Transportation Officials (AASHTO); “LRFD Bridge Design Specifications”.

-
- American Concrete Institute (ACI); “Building Code Requirements for Structural Concrete – ACI 318”.
 - American Railway Engineering and Maintenance-of-Way Association (AREMA); “Manual for Railway Engineering”.
 - American Society for Testing and Material (ASTM); “ASTM Standards in Building Codes”.
 - American Institute of Steel Construction (AISC); “Manual of Steel Construction, Load and Resistance Factor Design” or “Allowable Stress Design”.
 - American Society of Civil Engineers (ASCE); “Minimum Design Loads for Buildings and Other Structures”.
 - Minnesota Department of Transportation (MnDOT); “LRFD Bridge Design Manual”.
 - American National Standards Institute (ANSI).
 - Building Officials and Code Administrators (BOCA).
 - American Society of Mechanical Engineers (ASME).
 - American Welding Society (AWS).
 - Underwriters’ Laboratories, Inc. (UL).
 - National Fire Protection Association Standards and Guidelines (NFPA).
 - Minnesota Department of Labor and Industry (MDLI).
 - Metropolitan Council (Metro Transit).

Upon the discovery of any significant discrepancy between these structural design criteria and the prevalent standards, codes, and guidelines, the designer shall identify the discrepancy and notify the project engineer. The project engineer shall notify affected design personnel, take measures to resolve the discrepancy, and revise these design criteria, as necessary, for tracking changes.

7.1.3 Utility Relocation

There are existing utilities located within the proposed CCLRT alignment corridor. Final planning for utility relocation and/or for support of utilities will need to be resolved as information on utilities becomes available.

7.2 MATERIALS

The basic structural materials for the below grade elements of the station structures are described in this section. The materials include cast-in-place concrete, prestressed concrete, reinforcing steel, prestressing steel, and structural steel. Materials shall conform to prevalent national standards as indicated herein. Any materials not covered by standards listed herein shall be approved by Metro Transit and tested, if applicable, by an approved independent agency.

The designer may attempt to modify the material property requirements listed herein for specific applications by demonstrating, to the full satisfaction of the project engineer, the adequacy for using other materials. As part of this process, the designer shall include realistic assessments of the associated cost savings and describe in detail the risks

associated with using these other materials. Once the project engineer is satisfied with the use of these other materials, the project engineer shall seek approval from Metro-Transit and then notify appropriate design personnel whom will be affected by these changes. The project engineer shall revise these design criteria, as necessary, for tracking changes.

7.2.1 Materials used with Structural Concrete

The structural concrete used on the CCLRT project includes reinforced cast-in-place concrete; however, precast and prestressed concrete may also be used as necessary. Steel bars will be used for reinforcing the concrete; and the wires and bars indicated below will be used for prestressing the concrete as needed. Design of concrete structures subject to LRV loading shall be in accordance with the latest edition of AASHTO unless otherwise noted; Concrete structures not subject to LRV loading shall be designed, unless otherwise noted, in accordance with the requirements from the latest edition of ACI – 318.

7.2.1.1 Reinforced Cast-in-Place Concrete

Table 2.1 presents the cast-in-place reinforced concrete minimum 28-day compressive strengths.

Table 2.1 – Reinforce Concrete Application.

Application	Strength, f'_c
Structural concrete.	4,000 PSI
Station platforms and all columns.	5,000 PSI
Mud and protection slabs	3,000 PSI
Lean concrete used for filling cavities and other non-structural miscellaneous use, where future excavation is not anticipated.	1,000 PSI to
Flowable fill, where future excavation is not anticipated.	2,000 PSI

7.2.1.2 Prestressed Concrete (as needed)

The concrete for prestressed members shall have a minimum 28-day compressive strength of 5,000 psi at 28 days, and at time of initial prestress, the concrete shall have a minimum compressive strength of 3,500 psi.

7.2.1.3 Reinforced Steel Bars

All mild steel reinforcement bars shall be AASHTO M31 (ASTM A615), Grade 60 steel, $F_y = 60$ ksi, $f_s = 24$ ksi. Reinforcement shall be either black steel bars or epoxy coated steel bars based on the aggressiveness of the groundwater. The corrosive potential of the groundwater should be established by environmental testing of the groundwater.

7.2.1.3.1 Minimum Cover

The following dimensions for minimum cover shall apply:

1. Concrete cast against and permanently exposed to earth, including slurry wall construction and base slabs cast against mud slabs: 3"
2. Concrete slabs directly beneath railway surfaces: Top Reinforcement: 2 1/2"
3. Transition structure walls at rustication joints: Cover to Reinforcement at rustication Joints: 1 1/2"
4. Concrete surfaces exposed to earth or weather:
 - a. Walls and slabs (except as per Items 2 & 3): 2"
 - b. Beams and columns, stirrups, ties and spirals: 2"
5. Concrete surfaces not exposed to weather or in contact with earth:
 - a. Walls and Slabs (except as per Items 2 & 3): 1 1/2"
 - b. Beams and columns, stirrups, ties and spirals: 1 1/2"
6. All other concrete cover requirements shall be in accordance with "AASHTO Bridges" Clause 8.22.

7.2.1.3.2 Longitudinal Reinforcement Placement

Longitudinal reinforcing steel for tunnel and transition structures will be detailed as the innermost layer of reinforcing steel.

7.2.1.3.3 Spacing of Reinforcement

Main reinforcing bars shall be spaced at 6 inches, 9 inches, or 12 inches on center in the major structural elements. Exceptions to this rule include beams, columns, stairways and thin slabs. This requirement is intended to simplify design, checking of bar placement and field inspection. Spacing should also consider ease of concrete placement, space for embedded items, and crossings of reinforcement.

7.2.1.4 Prestressing Steel (as needed)

Prestressing reinforcement shall be high-strength steel wire, high strength seven wire strand, or high-strength alloy bars. High-strength steel wire shall conform to AASHTO M204 (ASTM A421). High-strength seven-wire strand shall conform to AASHTO M203 (ASTM A416) Grade 270, low relaxation. High-strength alloy bars shall conform to AASHTO M 275 (ASTM A722).

7.2.2 Structural Steel Materials

Steel frames and similar structures not subject to LRV loading and individual structural-steel elements not subject to LRV loading shall be designed, unless otherwise directed, in accordance with the requirements from the latest edition of AISC – Manual of Steel Construction; “Load and Resistance Factor Design” (LRFD) or “Allowable Stress Design”.

Provisions shall be made in structural steel frameworks of at grade structures for the temporary accommodation of fabrication and erection tolerances without introducing significant distortions in the frame.

Table 2.2 provides the appropriate references for the material requirements to be used with structural steel applications.

Table 2.2 – Structural Steel Application.

Steel Material	Reference
Structural steel	AASHTO M270 (ASTM A709 or ASTM A572), Grade 50
Steel piping	ASTM A53, Grade B (Type E or S), $F_y = 35$ ksi
Structural tubing	ASTM A500, Grade B, $F_y = 46$ ksi
High strength bolts	AASHTO M164 (ASTM A325)
Anchor bolts	ASTM A307

7.2.3 Shrinkage & Thermal Crack Control

Minimum longitudinal reinforcement requirements are established for structures based on minimizing crack widths that can occur due to early age shrinkage.

7.2.3.1 Longitudinal Shrinkage

Cut and cover structures will be designed to limit early-age thermal crack widths to a value not exceeding 0.012 inches. This is an estimated value based on ACI Committee 224, "Control of Cracking in Concrete Structures", Table 4.1 Tolerable Crack Widths, Reinforced Concrete for an exposure condition of humidity, moist air or soil.

For concrete retaining structures, reinforcement required to control early-age thermal crack widths may be calculated from the following:

$$p = \frac{f_{ct} \phi \alpha (T_1 + T_2)}{f_b 2w_c 2}$$

Where,

p = Steel ratio (total reinforcement in the face under consideration) based on the area of the surface zone at 10 inches deep maximum.

f_{ct} = Ratio of tensile strength of the concrete to the average bond strength = 0.67

f_b = Actual bending stress

\varnothing = Reinforcing bar diameter

w_c = Crack width

α = Coefficient of thermal expansion of concrete

T_1 = Temperature Difference between peak heat of hydration and ambient = 50 °F

T_2 = Seasonal temperature variation = 45 °F.

7.2.3.2 Transverse Shrinkage

Transverse shrinkage will be directly evaluated during analysis & design of the tunnel & transition structures, in accordance with AASHTO.

7.2.4 Flexural Crack Control

Flexural crack widths shall not exceed a maximum of 0.012 inches. In addition, the stress in the tension reinforcement at service load shall not exceed that given by equation 8-61 of "AASHTO Bridges", with the value of z being taken as 130 kips/in.

Minimum longitudinal reinforcement for soil supported tunnels, where significant heave and settlement may occur, shall be 1.2 times the cracking moment of the box structure in accordance with "AASHTO Bridges" Section 8.17.1.1. Elsewhere the smaller value of section 8.17.1.2 will be used.

7.2.5 Joints

7.2.5.1 Expansion Joints

Provisions for expansion shall be made in all at grade structures. Where a structural element is partially underground and partially above ground, and where an above ground element is attached to an underground element, particular care shall be taken in detailing to accommodate differential thermal movements.

Reinforcing steel shall not be continuous through the joint. Shear forces shall be transferred across the joint preferably by a key; alternatively, smooth dowels may be embedded on one side of the joint and provisions made on the other side to break the dowel bond and to provide space for dowel movement. All expansion joints in base and roof slabs and in walls against earth shall contain a nonmetallic waterstop with a minimum width of 9 inches. Thorough consideration shall be given to ensuring structural integrity and watertightness. Expansion joint locations shall be indicated in drawings.

7.2.5.2 Contraction Joints

Contraction joints shall be provided in at grade structures at intervals not greater than 32 feet. Contraction joints shall be unbonded joints and designed not to transmit the forces perpendicular to the joint that may occur under any design condition, and shall be designed according to the criteria described above for expansion joints.

7.2.5.3 Construction Joints

Construction joint locations and details shall be indicated on the drawings.

7.3 DESIGN LOADS

As a minimum, all components of underground structures shall be designed for the applicable dead loads, live loads, hydrostatic loads, and earth loads. Effects of erection and other temporary loads that might occur during construction shall also be considered.

7.3.1 Dead Load - (D)

Dead loads shall consist of the weight of the basic structures, the weight of the secondary elements that are permanently supported by the structure, and the weight of earth cover supported by the structural roof acting as a simple gravity load. These loads include miscellaneous loads of any system or facility that shall apply a permanent load on the structures and include loads from adjacent structures that impose dead load unless these adjacent structures are known to be independently supported or outside the zone of influence of the excavation.

Examples of dead loads include earth cover, permanent walls, slabs, beams, columns and other fixed structural members, trackwork, track support systems, walls, partitions, electrical equipment, service walks, parapet walls, pipes, conduits, cables, catenary power, signalization and communication equipment, poles and other utility services.

7.3.1.1 Unit Weights of Materials

To assure that dead load calculations are consistent throughout the project activities, Table 3.1 presents the unit weights for various materials.

Table 3.1 – Material Unit Weights.

Material	Unit Weight
Plain concrete	145 PCF
Reinforced concrete	150 PCF
Infill concrete	145 PCF
Steel or cast steel	490 PCF
Cast Iron	450 PCF
Aluminum Alloys	175 PCF
Glass	160 PCF

Timber		60 PCF
Ballast or crushed stone		120 PCF
*Compacted sand, gravel, earth (flotation case)	Saturated	110 PCF
	Buoyant	48 PCF
*Compacted sand, gravel, earth (all other cases)	Saturated	130 PCF
	Buoyant	68 PCF
Masonry	Brick	125 PCF
	Rock and Stone	160 PCF
Pavement		150 PCF
Groundwater		62.4 PCF

*Note: The unit weights of the soil to be used for structural design shall be refined based on information obtained from the geotechnical investigations. In the interim, the unit weights presented in Table 3.1 shall be used.

7.3.1.2 Superimposed Dead Loads

Table 3.2 presents the magnitudes for various superimposed dead loads applied to the structure after the structure has been completed.

Table 3.2 – Superimposed Dead Loads.

Dead Load Type		Load
Partition Walls		20 PSF
Epoxy terrazzo tile, 3/8 inch		5 PSF
Terrazzo (1 inch), plus 2 inch stone concrete		30 PSF
Stay in place forms		15 PSF
Ceilings	cement plaster	15 PSF(or actual)
	gypsum plaster	10 PSF(or actual)
Light fixtures		5 PSF
Electrical systems		15 PSF
Signal/communication equipment		10 PSF
Mechanical systems		15 PSF
Steel grid safety walk		85 PSF
Signs and supports		5 PSF
Rails and fasteners (no ties)		200 PLF/TRK
Electrification (third rail system and fastenings)		450 PLF/TRK
Cable splice boxes (maximum length 30 feet)		160 PLF
Acoustical barrier		350 PLF
Hand rails		10 PLF
Line utilities		20 PLF

7.3.2 Earth Loads

Earth materials have limited shear strength; therefore, earth loads have to be applied in both the vertical and horizontal direction. The structure may also be affected by differential settlement.

7.3.2.1 Vertical Earth Loads – (EV => D)

Vertical earth loads act as dead loads as mentioned previously. Except for the flotation case, the vertical earth load shall be based on the soil weight computed from the greater height of soil cover:

- The ground surface to the top of the structure roof.
- The roadway crown to the top of the structure roof.
- The top of any officially proposed street grade to the top of the structure roof.

For the flotation case, use the minimum height of soil cover shall be used.

7.3.2.2 Lateral Earth Loads – (EH)

Lateral earth loads are complex and must be developed in consultation with the geotechnical engineer. Finite element analysis will be used to refine the lateral earth pressure distribution after the material properties have been established by the geotechnical engineer. In the interim, lateral earth pressure shall be calculated using lateral earth pressure coefficients, which assign a portion of the vertical earth pressure to act in the lateral direction. Table 3.3 presents the interim lateral earth pressure coefficients to be used for rigid and flexible walls. These coefficients should also be refined by the geotechnical engineer based on the results of the geotechnical investigation and local experience at the site area.

Wall Type	Interim Lateral Earth Pressure Coefficients
Rigid	0.7 (At-Rest)
Flexible	0.35 (Active)

Table 3.3 – Interim Lateral Earth Pressure Coefficients.

Wall systems are classified as either flexible or rigid. To be considered flexible, the wall must meet the rotation requirements of AASHTO Table 5.5.2A. Examples of rigid wall systems include reinforced concrete slurry walls, soldier pile tremie concrete (SPTC), tangent or secant piles, and other similar systems. Examples of flexible wall systems include interlocking sheetpile walls, soldier pile and lagging, and other similar systems.

7.3.2.3 Differential Settlement

Differential settlement shall be considered in the longitudinal analysis of the tunnel. At a minimum, a longitudinal beam model on elastic foundation must be analyzed based on the actual ground profile.

7.3.3 Hydrostatic Pressure – (H) and Buoyancy – (B)

The effects of hydrostatic pressure and buoyancy shall be considered whenever the presence of groundwater is indicated. It shall be computed at 62.4 pounds per square foot per foot of depth below the design groundwater level for the case being analyzed. Groundwater levels to be used in design shall be refined by the geotechnical engineer as part of the geotechnical investigation. Long term variations in the groundwater level and the possibility of significant future changes in groundwater elevation shall be considered in establishing the design groundwater levels. When hydrostatic pressures are applied, lateral earth pressures shall be computed using the submerged weight of soil. When buoyancy is considered, the dead weight of the structure, without internal super imposed dead loads, shall be applied.

7.3.4 Live Loads – (L)

The live load shall consist of the weight of all non-permanent loads, including system loads from Light Rail Vehicle (LRV) loads and maintenance vehicle loads. The designer shall determine the configuration, spacing and arrangement producing the most critical conditions for axial, bending, shearing stresses, and deflections.

7.3.4.1 Light Rail Vehicle Axle Loads

The axel loads are based on the LRVs currently used by the Metro Transit in Minneapolis. The axle spacing, axle loading and vehicle spacing loads are depicted in Figure 18-1 of Section 18 of this Design Criteria. The axel loadings are approximate. Loadings from maintenance vehicles shown in Figure 18-1 shall also be taken into consideration as they are likely more severe. These vehicles are assumed to operate as single-vehicle units and as multi-vehicle units. The vehicular loads provided shall be used in the design of underground structures and used for stress and deflection calculations, as either single-vehicle units or as multi-vehicle units.

Where wheel loads are transmitted to a slab through rail mountings placed directly on the slab, longitudinally, the wheel load shall be assumed as uniformly distributed over three feet of rail, plus twice the effective depth of the slab, limited, however, by axle spacing. This load may be distributed transversely by the width of the rail fastener pad, plus the effective depth of the concrete slab section.

Where wheel loads are transmitted to a slab through ballasted sections, longitudinally, the wheel load shall be assumed as uniformly distributed over a length of three feet of rail, plus the depth of the ballast under the tie, plus twice the effective depth of the slab, limited by the axle spacing. This load may be distributed transversely over the

length of the track tie, plus the depth of the ballast and the effective depth of the concrete slab section.

7.3.4.2 Light Rail Vehicle Impact Loads

Where rail is supported by slab on grade, no vertical impact needs to be considered for a LRV. Where rail is supported by a structural element with a span, the vertical impact load shall be determined in accordance with the provisions of Article 8.2.2.3, “Impact formula” of AREMA. The impact load shall be added to the live load as a percentage of weight and distributed the same as the axle load.

7.3.4.3 Light Rail Vehicle Derailment Loads – (DR)

The vertical derailment load shall be that produced by the LRV, including 30-percent impact, placed with its longitudinal axis parallel to the track and two feet from the centerline of track at each side, or to the nearest obstruction.

The horizontal force due to derailment shall be taken as 40% of the dead load of a single fully loaded vehicle acting two feet above top of rail and normal to the barrier wall for a distance of 10 feet along the wall.

7.3.4.4 Loads from Roadways

The live load from any roadway shall be based on HL-93 Loading, including consideration of the design tandem, of the AASHTO Code as defined by AASHTO 3.6.1.2, whichever produces a more onerous design. The distribution of wheel loads through earth fills shall be as follows:

1. If depth of fill is less than 2 feet: wheel loads shall be applied as concentrated loads directly on the structure.
2. If depth of fill is greater than 2 feet: wheel live loads shall be distributed over a square area, the sides of which are equal to 1.15 times the depth of fill. When distribution areas overlap, the total load shall be uniformly distributed over an area defined by the outside limits of the individual areas.

The depth of fill shall be measured from the top of ground or pavement to the top of the underground structure. For the design of underground structures subject to roadway loading, the impact load shall conform to Table 3.4. Slab on grade shall not be subject to impact loading consideration.

Table 3.4 – Roadway Impact Loads

Height of Fill (HoF)	Impact Load
HoF < 1 ft	30 %
1 ft < HoF < 2 ft	20 %
2 ft < HoF < 3 ft	10 %
3 ft < HoF	0 %

7.3.4.5 Service Loads from Non-Vehicles

The uniformly distributed and concentrated non-vehicular service loads are presented in Table 3.5. The loads provided shall represent the minimum design loads for each load item type. Concentrated load shall be positioned so as to produce the most critical condition for axial, bending and shear stresses, and for deflections.

Table 3.5 – Non-Vehicle Service Loads

Load Item	Uniform	Conc.	*Notes
Roof	30 PSF		1
Sidewalk	600 PSF		
Service walk, Stairs, Platforms or Mezzanines	150 PSF		1, 8
Chiller room	150 PSF	15 Kips	2, 8
Air cooling unit room	150 PSF	1 Kip	2, 8
Fan area	150 PSF	5 Kips	2, 3
Control or Electrical panel rooms	150 PSF		8
Elevator machine room and Elevator pit			4, 8
Escalator machine room	150 PSF	2 Kips	2, 5
Escalator pit	150 PSF		5, 8
Ejector room	150 PSF	1 Kip	2, 8
Pump or Electrical distribution rooms	250 PSF	5 Kips	2, 8
Sump room			6, 8
Circuit breaker house	200 PSF	2 Kips	2, 8
Relay, Central instrument, or Signal tower control rooms	150 PSF	1 Kip	2, 8
Communication room	150 PSF		2, 8
Telephone compartment or Compressor rooms	150 PSF		8
Substation - transformer area	300 PSF	15 Kips	2
Substation - circuit breaker platform	300 PSF	6 Kips	2
Track lubrication or Maintenance service rooms	150 PSF		8
Various quarters	150 PSF		7, 8
Rail storage space	400 PSF		

***Notes:**

1. In designing elevated columns, use one-half of the uniformly distributed live load.
2. For one-way or two-way floor slabs or floor beams, use the uniformly distributed live load over the entire floor area, or a pattern loading, plus the concentrated live load in a location that would produce maximum stresses on the member. Pattern loading shall be applied to induce the maximum positive and negative stresses.
3. Non-vehicular loading is to be used for under platform exhaust fan rooms, fan chambers, fan work areas and other areas supporting similar size fans.
4. The design live load must be determined for each location in consultation with the mechanical design discipline. The equipment live load shall be increased to include impact. A minimum uniformly distributed live load of 150 psf shall be used on all floor areas designated as mechanical rooms or areas. Supporting structures shall be designed for the maximum reactions from any of the manufactured units.
5. Structures supporting escalators or passengers conveyors shall be designed for the maximum reactions from any of the manufactured units. Approximate design live loads are given for escalators for rises under 33 feet. For longer escalators, note 4 shall apply.
6. Design live loads must be determined on the basis of maximum hydrostatic pressure and external earth pressure, where applicable.
7. This design live load applies to quarters for personnel such as, foreman, dispatchers, trackmen, as well as tool rooms, work-shops and "light" storage rooms.
8. Hand Rails and fences shall be designed to withstand a horizontal force of 50 lb/ft, inward or outward, applied at the top of the railing and perpendicular to the plane of the railing and a vertical force of 50 lb/ft. Railings in equipment rooms and working areas shall also be designed for a concentrated load of 300 lb applied in any direction.

Additionally, the floors and supporting structural members in substations, switch rooms, electrical or mechanical plant rooms or other areas containing switch gear or machinery, shall be designed for:

1. The full live load as per Table 3.5, or the full dead load of the assembled piece of equipment at any reasonable position on the structure likely to be positioned during or after installation, plus 150 PSF on the floor area outside the equipment footprint, whichever produces the maximum stresses.
2. In addition, ancillary areas such as electrical/mechanical rooms, pump rooms, substations, etc., shall be designed for a superimposed dead load to account for attachments supported to the underside of floor slabs and beams as given in Table 3.6.

Table 3.6 – Additional Ancillary Area Loads

Floor Area (FA)	Uniform Load
FA < 100 feet ²	40 PSF
100 feet ² < FA < 300 feet ²	30 PSF
FA > 300 feet ²	20 PSF

7.3.5 Surcharge Loads

Surcharge loads are applied in both the vertical and horizontal direction in a manner similar to earth loads.

7.3.5.1 Vertical Surcharge Loads – (SV)

For tunnel roofs, minimum vertical surcharge loading of the intensity shown in Table 3.7 shall be applied to simulate conditions during future construction and other undefined miscellaneous surface loading.

Table 3.7 – Vertical Surcharge Loads

Depth	Load
< 5 FT	600 PSF
5 FT through 20 FT	600 – 40 x (Depth – 5 FT) PSF
> 20 FT	Zero Intensity

Finite element analysis will be performed to generate the distribution of vertical surcharge loading once the material properties have been established by the geotechnical engineer. In the interim, Figure 3.2 should be used to approximate the distribution of vertical loading until more elaborate finite element analyses are performed.

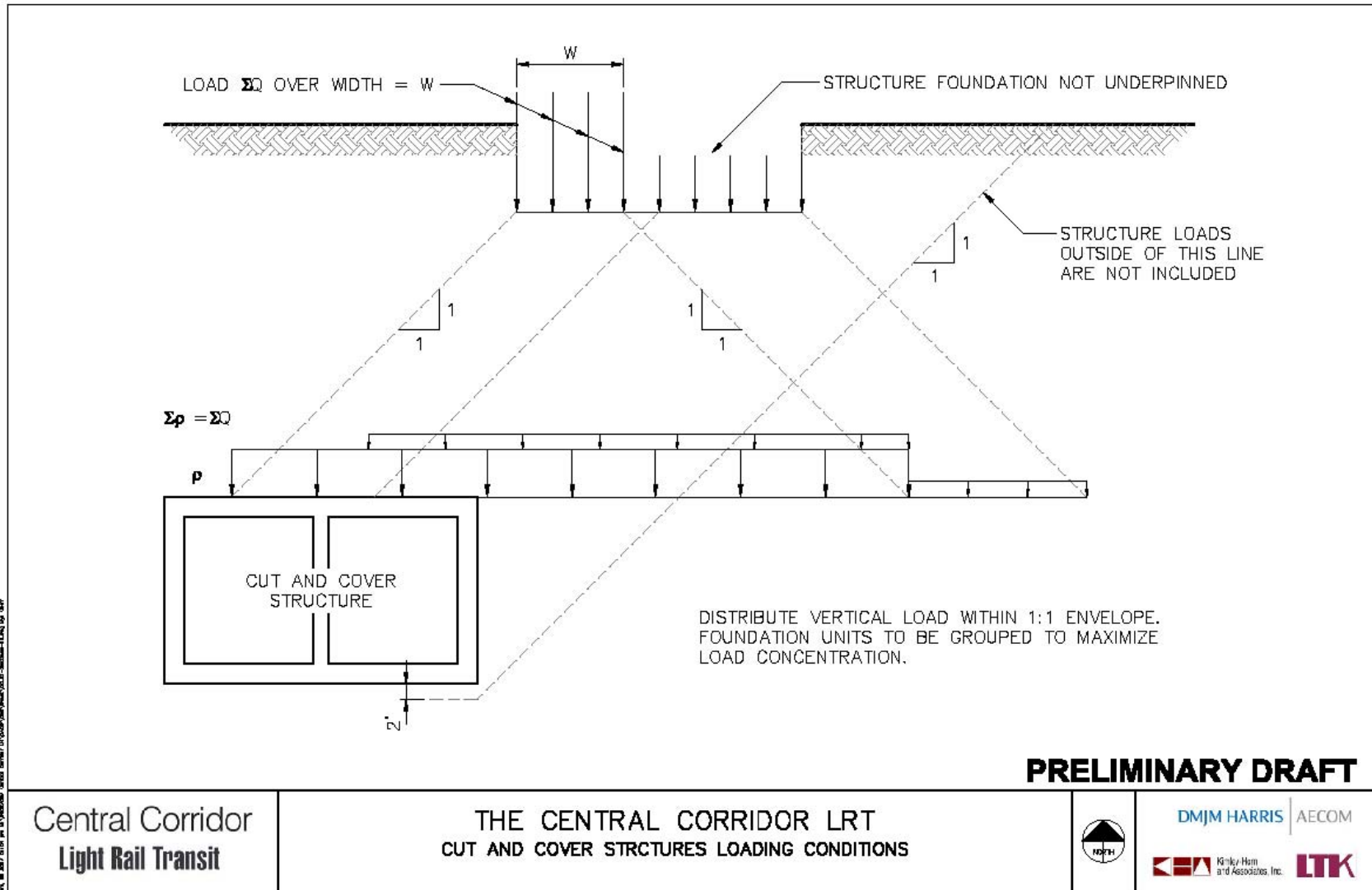
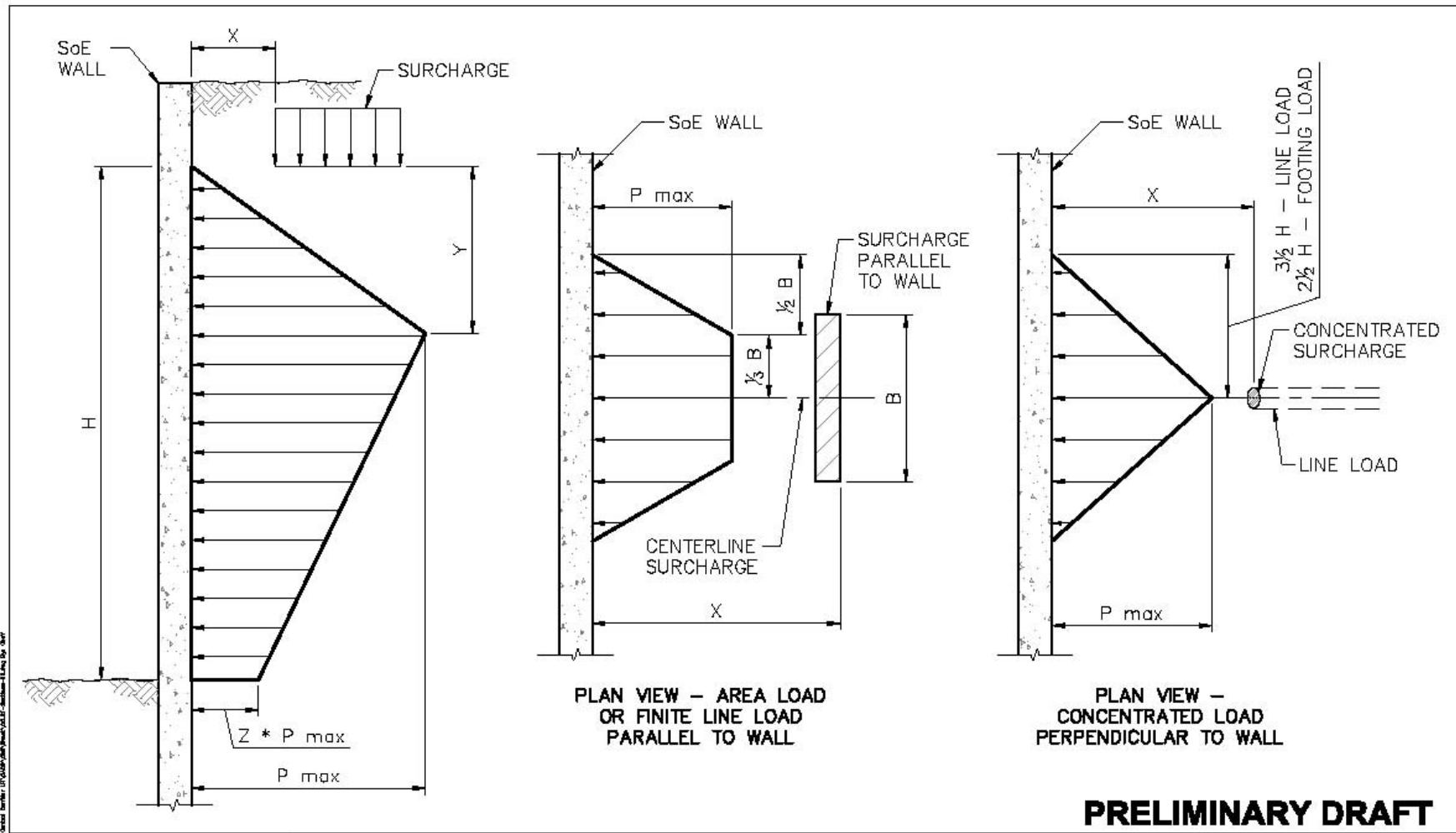

Figure 3.2 – Approximate Influence Zone from Vertical Surcharging

7.3.5.2 Horizontal Surcharge Loads – (SH)

For underground structures, finite element analysis shall be performed to generate the lateral component of surcharge pressures once the material properties have been established by the geotechnical engineer. In the interim, lateral pressure distribution will be applied as depicted in Figure 3.3 and further defined in Table 3.8.

The distributions of horizontal pressures shown in Figure 3.3 are approximately twice the values given by elastic solutions for the distribution of horizontal pressures in soil due to superimposed loads. The loads are doubled to take into account the rigidity of the box section.



Central Corridor
Light Rail Transit

THE CENTRAL CORRIDOR LRT
LATERAL PRESSURE DUE TO VERTICAL SURCHARGE



DMJM HARRIS | AECOM
Kirkley Ham and Associates, Inc. | LTK

Figure 3.3 – Lateral Component Surcharge Diagram

If building foundations are underpinned, then the transfer of building load to a lower level should be considered in evaluating resultant lateral pressure using procedures acceptable to the geotechnical engineer.

Symbols:

- B Length of area loaded parallel to wall.
- H Vertical distance between the horizontal loaded plane and bottom of excavation.
- P_{max} Calculated lateral pressure due to surcharge; for surcharge of existing buildings, use $\frac{1}{2}$ the calculated value.
- Q Vertical surcharge intensity.
- X Distance from wall to footing or parallel line load or to leading edge of area loaded or perpendicular line load.

Table 3.8 – Variables used with Lateral Component Surcharge Diagram

Load Case	y	z	P_{max}
Isolated (individual) footing considered as point load	0.6 H	0.4	$\{2.1 - 1.8 \cdot x\} \cdot Q / H^2$
Continuous footing – line load perpendicular to wall	0.6 H	0.4	$\{1.4 - 1.2 \cdot x\} \cdot Q / H^2$
Continuous footing – line load parallel to wall	0.4 H	0.25	$\{1.1 - 0.5 \cdot x\} \cdot Q / H$
Area load	0.4 H	0.25	$\{0.8 - 0.5 \cdot x\} \cdot Q / H$

7.3.5.3 Surcharge Loads from Buildings

Loads from existing buildings shall be based on actual design loads, as available, or code requirements.

Vertical and lateral loads on underground structures that result from existing structures above or adjacent to these structures shall be distributed as shown on Figures 3.2 and 3.3. This approximate procedure is intended for non-underpinned foundations.

7.3.5.4 Surcharge Loading from Future Structures

In areas where future development is anticipated, appropriate loads shall also be considered.

7.3.6 Thermal and Shrinkage Stresses and Strains – (TS)

Thermal strains will result in stresses within structural elements when movement is restrained. When calculating these thermal induced stresses and strains for expansion or contraction, the following constants shall apply:

-
1. The range of temperature variation during concrete construction, and also during normal operations shall have a baseline ambient temperature of 50° and be as follows:
Temperature rise/fall – during construction: a temperature fall of 50 °F and a temperature rise of 40 °F.
Temperature rise/fall – post construction of interior structural members: a temperature fall of 45 °F and a temperature rise of 35 °F.
Coefficient of Thermal Expansion, Concrete $6.0 \times 10^{-6} / ^\circ\text{F}$
Coefficient of Thermal Expansion, Steel $6.5 \times 10^{-6} / ^\circ\text{F}$
 2. For calculating forces induced by shrinkage and thermal effects, the effective modulus of elasticity of concrete during early age will be taken as ½ the value of E_c given in AASHTO, Section 8.7.
 3. The shrinkage coefficient will be taken as 0.00025 in/in.

Special consideration will be given to the potential for construction temperature gradients in tunnel, transition, and station reinforced concrete elements. The gradient is formed between the buried face of concrete slabs (presumed to be constant at the ground ambient temperature of 50°F), while the ambient air temperature varies with the season. This gradient induces flexural stresses, which can develop into cracking. Consider a temperature fall of 45 °F and a temperature rise of 35 °F on all members.

7.3.7 Seismic Loads (EQ)

As depicted in Figure 3.4 taken from the United States Geological Survey (USGS), Minneapolis is in Seismic Hazard Zone 0; as a result, seismic effects are not a design consideration.

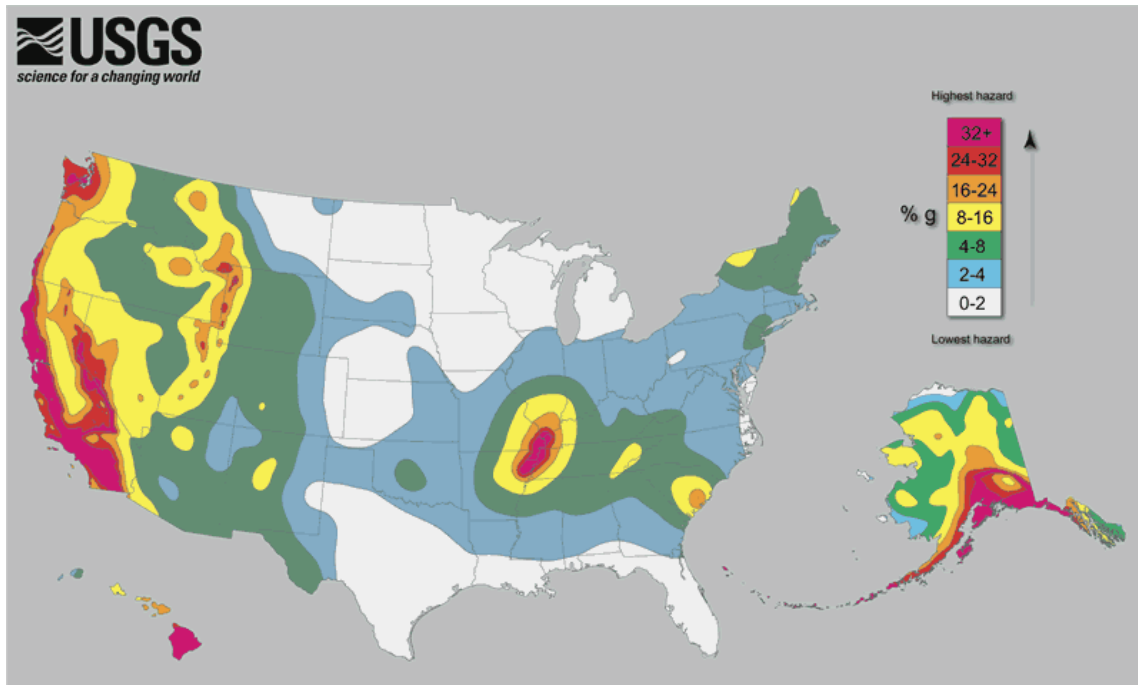

Figure 3.4 – USGS Seismic Hazard Map

7.4 GROUP FACTORS, LOAD FACTORS, AND LOAD COMBINATIONS

Design of structures shall be based on AASHTO Code except as indicated otherwise. All reinforced concrete structures shall be designed using the Ultimate Strength method; all steel structures shall be designed using Load and Resistance Factor Design. The load factors and minimum load cases are presented in this section. Additional temporary and general load cases shall be investigated as required by particular circumstances. The various load factors are presented in Table 4.1; and the minimum load combinations are presented in Table 4.2. These equations are a minimum and other load groups may be added.

Table 4.1 – Group and Load Factors

GROUP AND LOAD FACTORS											
LOAD TYPE	GROUP FACTOR □	LOAD FACTOR									
		□ _D	□ _{EV}	□ _{EH}		□ _{SV}	□ _{SH}		□ _H □ _B	□ _L	□ _{DR}
				Active	At-Rest		Active	At-Rest			
TMP1	1.2	*0.75	-	1.3	1.15	-	1.3	1.15	1	-	-
TMP2	1.2	1	1	1.3	1.15	1	1.3	1.15	-	1.67	-
GNRL1	1.3	1	1	1.3	1.15	1	1.3	1.15	1	1.67	-
GNRL2	1.3	1	1	£	£	-	£	£	1	1.67	-
GNRL3	1.3	1	1	£	£	1	£	£	1	1.67	-
GNRL4	1.3	1	1	1.3	1.15	1	1.3	1.15	1	1.67	0.8
TS1	1.25	#1									
TS2	1.25	#1									
TS3	1.25	#1									
TS4	1.25	#1									
EQ1	-										

Notes:
 *Self-weight only.
 £_{B_{EH}} = B_{SH} = 1.15 for wall that has more applied loads; 0.67 for opposite wall with less loads applied with at-rest conditions.
 = 1.3 for wall that has more applied loads; 0.67 for opposite wall with less loads applied with active conditions.
 #Superimposed loads onto general load conditions => use group factor indicated with load factors from general load conditions.

Table 4.2 – Load Combinations

	GENERALIZED LOAD EQUATIONS
TMP	$\gamma[\beta_D(D)+\beta_L(L)+\beta_{EH}(E_H)+\beta_{EV}(E_V)+\beta_{SH}(E_{SH})+\beta_{SV}(E_{SV})+\beta_H(H)+\beta_B(B)]$
GNRL	$\gamma[\beta_D(D)+\beta_L(L)+\beta_{EH}(E_H)+\beta_{EV}(E_V)+\beta_{SH}(E_{SH})+\beta_{SV}(E_{SV})+\beta_H(H)+\beta_B(B)]$
TS	$\gamma[\beta_D(D)+\beta_L(L)+\beta_{EH}(E_H)+\beta_{EV}(E_V)+\beta_{SH}(E_{SH})+\beta_{SV}(E_{SV})+\beta_H(H)+\beta_B(B)+Sh+T]$
EQ	Not Applicable for Minneapolis, Minnesota which is in Seismic Hazard Zone 0

7.4.1 Temporary Considerations

To reflect the temporary conditions that may be subjected to the structure, two temporary load cases shall be considered. Temporary construction procedures may result in conditions that are more severe than the general loading conditions. Stresses in the partially completed structure and in individual members shall be analyzed for appropriate critical conditions existing at the various stages of construction.

For such temporary conditions, the allowable stresses given for the various loading combinations may be increased by 50 percent, but without exceeding the ultimate strength capacity of the member when checked against non-factored loads. As a minimum, four load cases shall be investigated to demonstrate the adequacy of the structures to resist basic temporary loading situations.

7.4.1.1 Symmetrical Loading – Max. Horizontal Loads / Min. Vertical Loads

For the initial construction condition, the tunnel base slab, walls and roof slab will consider the full lateral earth pressure acting on the tunnel structure without earth cover over the tunnel roof to maximize the negative moment at the interface of the base-slab and side-wall.

Combine minimal vertical loads with maximal horizontal loads. Include self weight of structure for the vertical loads. Do not consider vertical loads from earth cover, live loads, and surcharge loads. Include hydrostatic pressure in vertical loading where applicable to reflect local groundwater conditions and design assumptions. Include earth pressures, hydrostatic pressures, and surcharge pressures for the horizontal loads. These combinations are depicted in Figure 4.1.

7.4.1.2 Symmetrical Loading – Max. Vertical Loads / Min. Horizontal Loads

For an intermediate construction condition, combine the maximum vertical loads with the minimal horizontal loads. For the vertical loads, include dead loads, live loads, and surcharge loads. For the horizontal loads, include active pressures from soil but do not include lateral live load, surcharge load or hydrostatic pressure. These combinations are depicted in Figure 4.2.

The designer shall consider the top slab as both restrained and unrestrained against horizontal translation in arriving at maximum shear, thrusts and moments for any underground concrete box structures that could be subject to unequal lateral pressures. However, the ratio of horizontal displacement to height of the wall need not exceed 0.0005.

7.4.2 General Considerations

To reflect the general conditions that may subjected upon the structure, four general load cases shall be considered. No increase in allowable stress may be considered.

7.4.2.1 Symmetrical Loading – Max. Vertical Loads / Max. Horizontal Loads

For the general condition, combine the maximum vertical loads with the minimal horizontal loads. For the vertical loads, include dead loads, live loads, and surcharge loads. Include earth pressures, hydrostatic pressures, and surcharge pressures for the horizontal loads. This general load combination is presented in Figure 4.3.

7.4.2.2 Asymmetrical Loading – Local Dewatering / Extended Surcharge

For the general condition, the horizontal loads are unbalanced due to local dewatering and extended surcharge. Combine the loads to produce the maximum differential horizontal loads acting on the structure. In addition to this maximum differential horizontal loading, combine the minimum vertical load. This general load combination is presented in Figure 4.4.

7.4.2.3 Asymmetrical Loading – Local Dewatering / Extended Overhead Surcharge

For the general condition, the horizontal loads are unbalanced due to local dewatering and extended overhead surcharge. Combine the loads to produce the maximum differential horizontal loads acting on the structure. In addition to this maximum differential horizontal loading, combine the maximum vertical load. This general load combination is presented in Figure 4.5.

7.4.2.4 Asymmetrical Loading – Derailment Loads

For the general derailment condition, the vertical derailment load shall be that produced by the LRV, including 30-percent impact, placed with its longitudinal axis parallel to the track and two feet from the centerline of track at each side, or to the nearest obstruction. The horizontal force due to derailment shall be taken as 40% of the deadload of a single fully loaded vehicle acting two feet above top of rail and normal to the barrier wall for a distance of 10 feet along the wall. This general load combination is presented in Figure 4.6.

7.4.3 Thermal Considerations

To reflect potential thermal and any shrinkage conditions to which the structure may be subjected, eight load cases shall be considered as a minimum. The thermal conditions shall be superimposed on the general load considerations mentioned previously with a slightly smaller group factor.

7.4.3.1 Thermal Loading – Uniform Temperature Change.

For the uniform temperature case, consider the uniform temperature change of all structural elements from the construction condition to the service condition as indicated previously in Section 3.6. Superimpose the resulting loads onto the four general loading conditions. Use the group factor and generalized load equation for temperature and shrinkage. Since the temperature is \pm , there are two load conditions to consider. These thermal load combinations are presented in Figure 4.7.

7.4.3.2 Thermal Loading – Non-Uniform Temperature Change.

For the non-uniform temperature case, consider the non-uniform temperature change for some of the structural elements from the construction condition to the service condition as indicated previously in Section 3.6. Superimpose the resulting loads onto the four general loading conditions. Use the group factor and generalized load equation for temperature and shrinkage. Since the temperature is \pm , there are two load conditions to consider. These thermal load combinations are presented in Figure 4.8.

7.4.3.3 Thermal Loading – Temperature Gradient across Structural Elements.

As mentioned previously, special consideration will be given to the potential post construction temperature gradients in tunnel, transition, and station reinforced concrete elements. The gradient is formed between the buried face of concrete slabs (presumed to be constant at the ground ambient temperature, while the ambient air temperature varies with the season.

For the temperature gradient across structural elements, consider the loads that result from temperature change across a structural element as indicated in Section 3.6. Superimpose the resulting loads onto the four general loading conditions. Use the group factor and generalized load equation for temperature and shrinkage. These thermal load combinations are presented in Figure 4.9.

7.4.3.4 Temperature Loading – Combined Uniform and Gradient Temperature.

For the combined temperature loading, consider, as indicated previously, the combined effect of a temperature gradient along one of the structural elements and also a uniform temperature change for all of the structural elements. Superimpose these loads onto the four general load conditions. Use the group factor and generalized load equation for temperature and shrinkage. These thermal load combinations are presented in Figure 4.10.

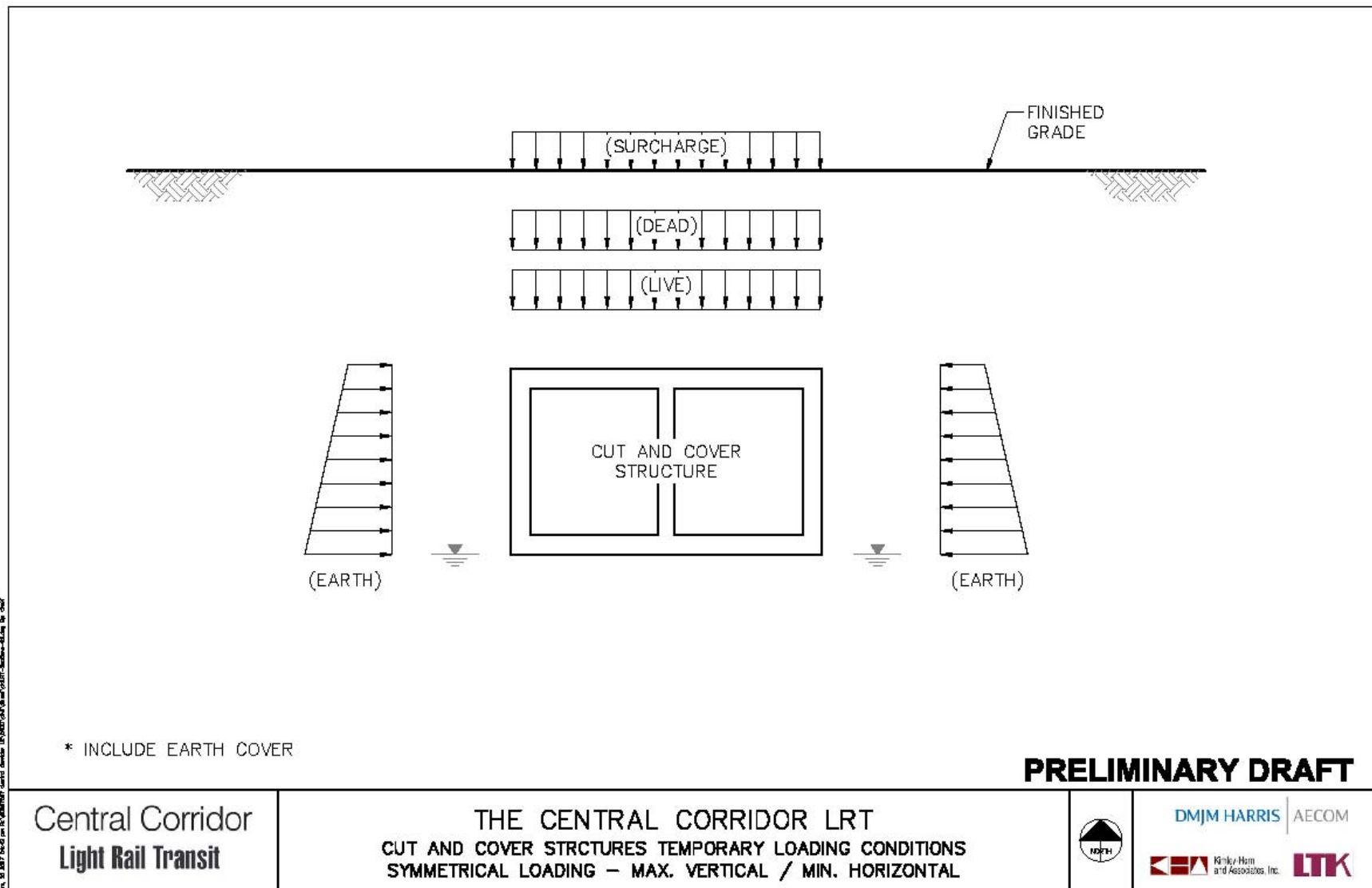

Figure 4.2 – Symmetrical Loading – Max. Vertical Loads / Min. Horizontal Loads (TMP2).

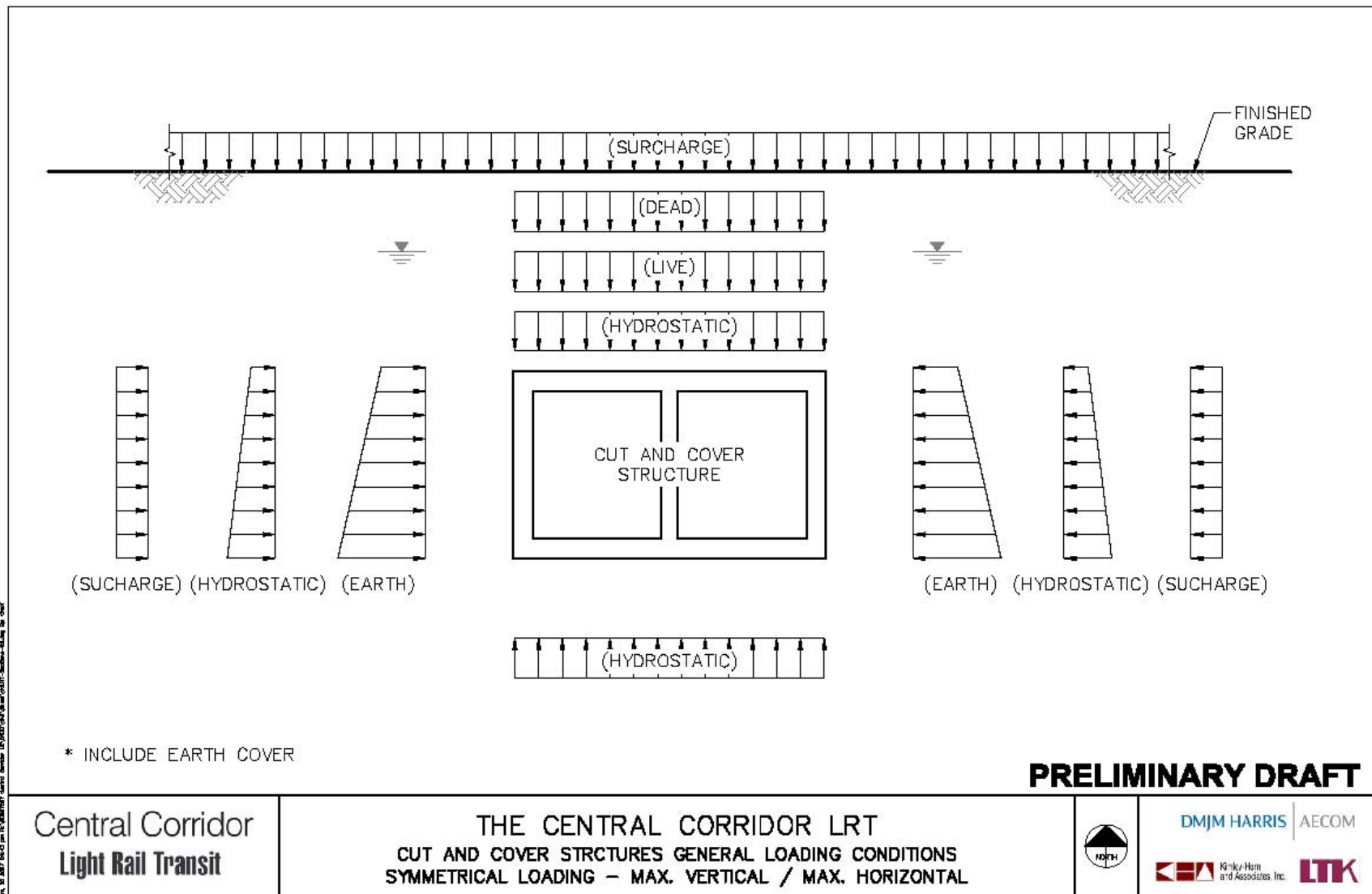

Figure 4.3 – Symmetrical Loading – Max. Vertical Loads / Max. Horizontal Loads (GNRL1).

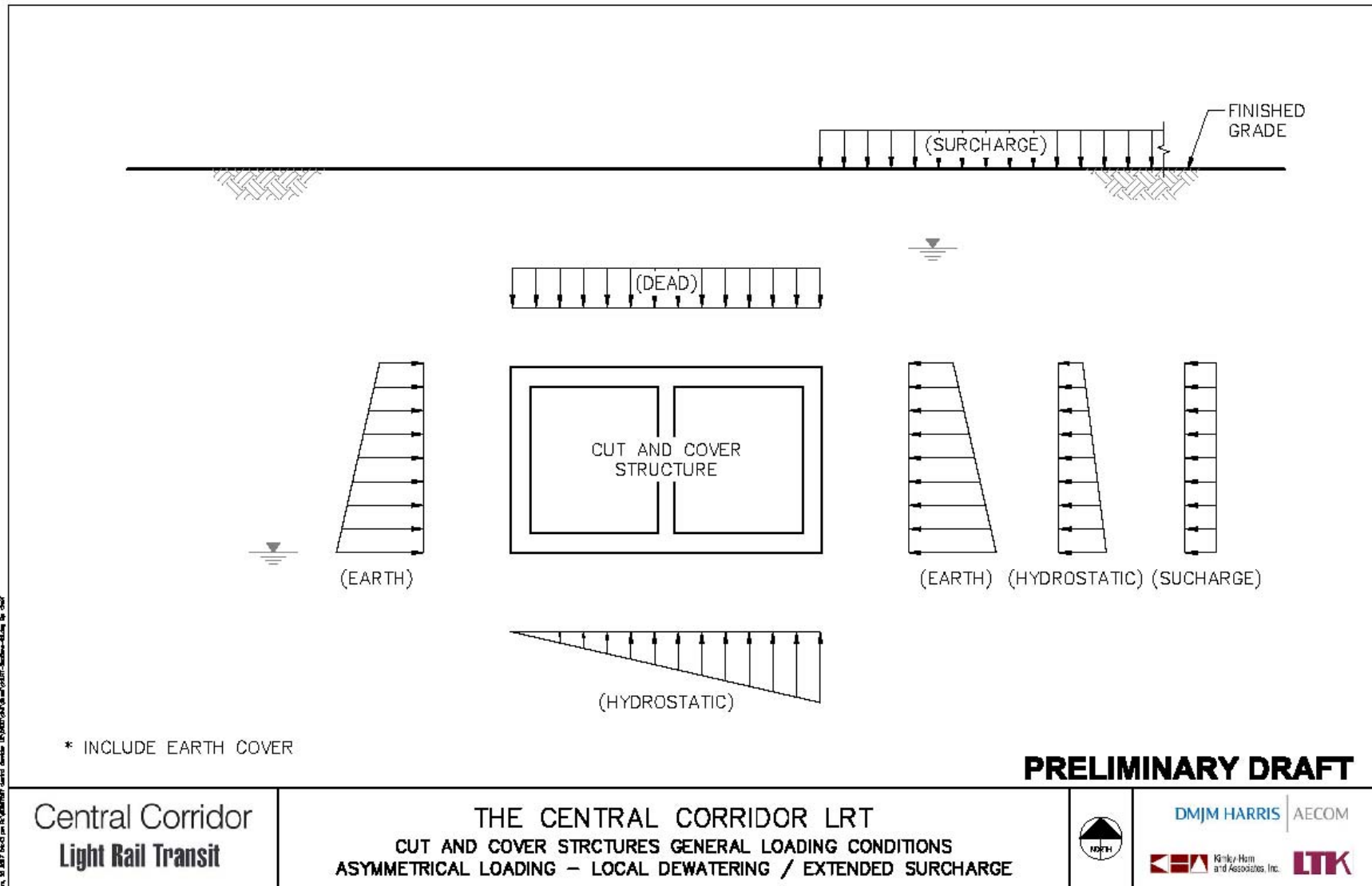

Figure 4.4 – Asymmetrical Loading – Local Dewatering / Extended Surcharge (GNRL2).

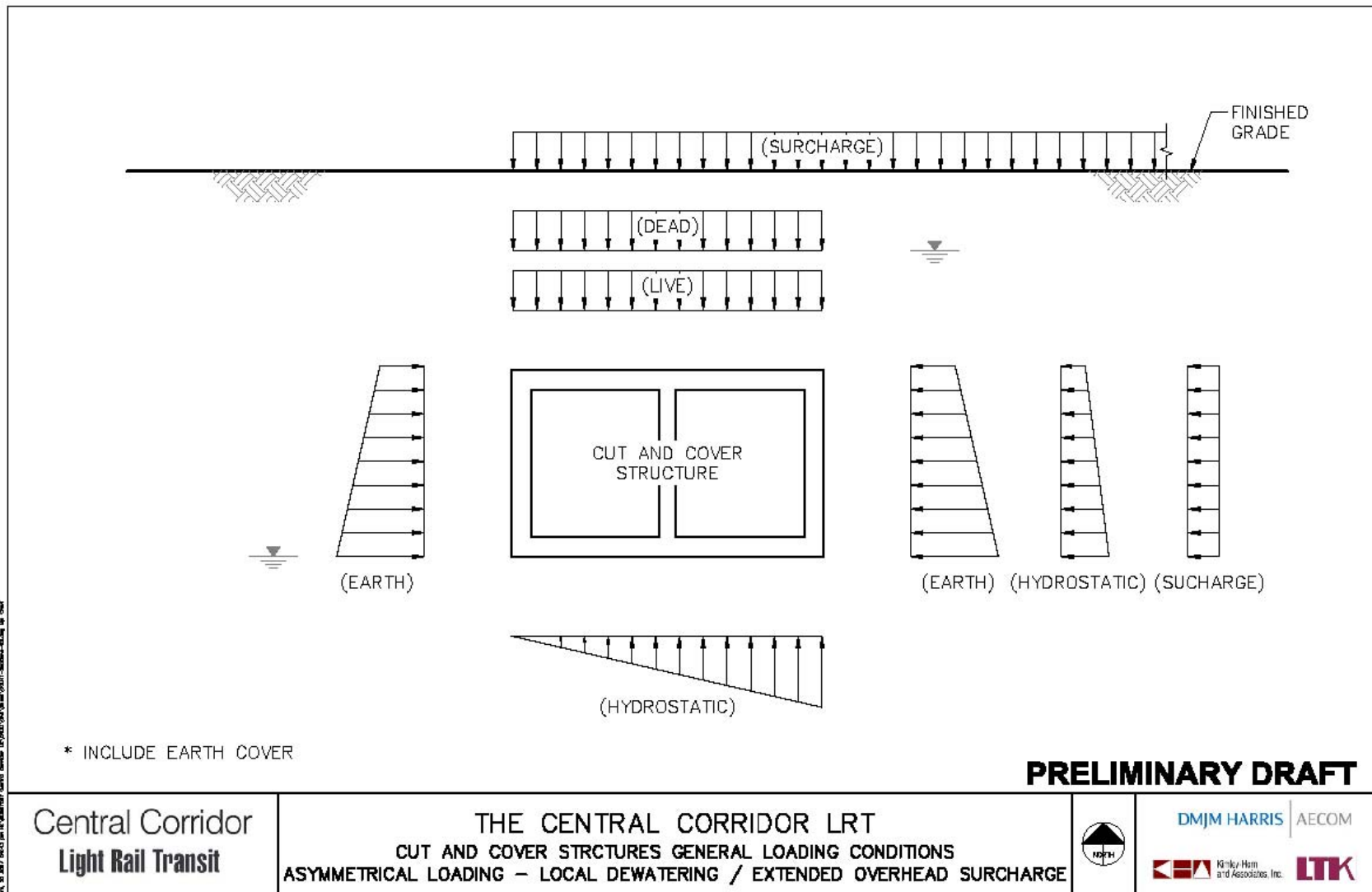

Figure 4.5 – Asymmetrical Loading – Local Dewatering / Extended Overhead Surcharge (GNRL3).

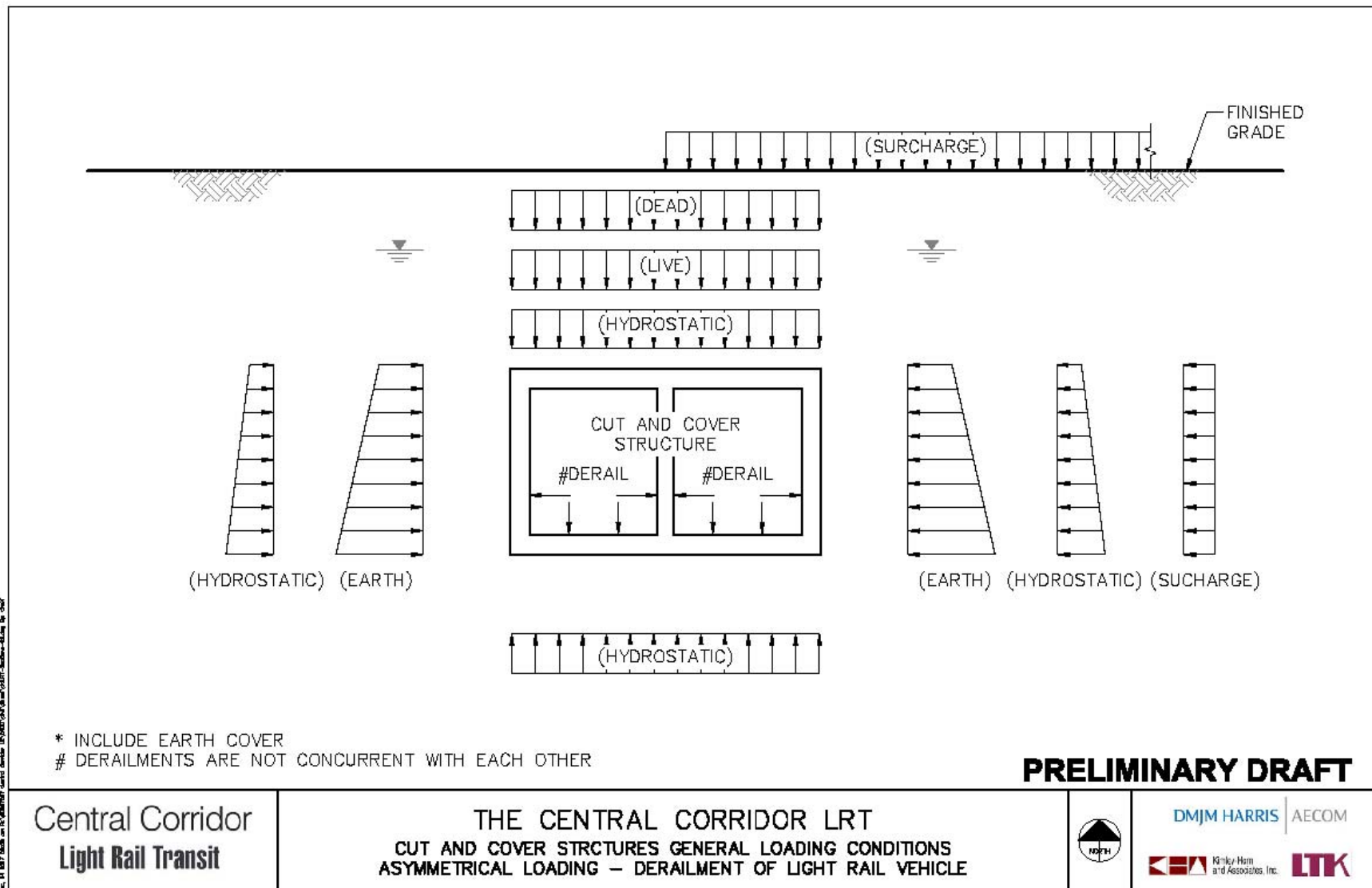

Figure 4.6 – Asymmetrical Loading – Derailment of LRV (GNRL4).

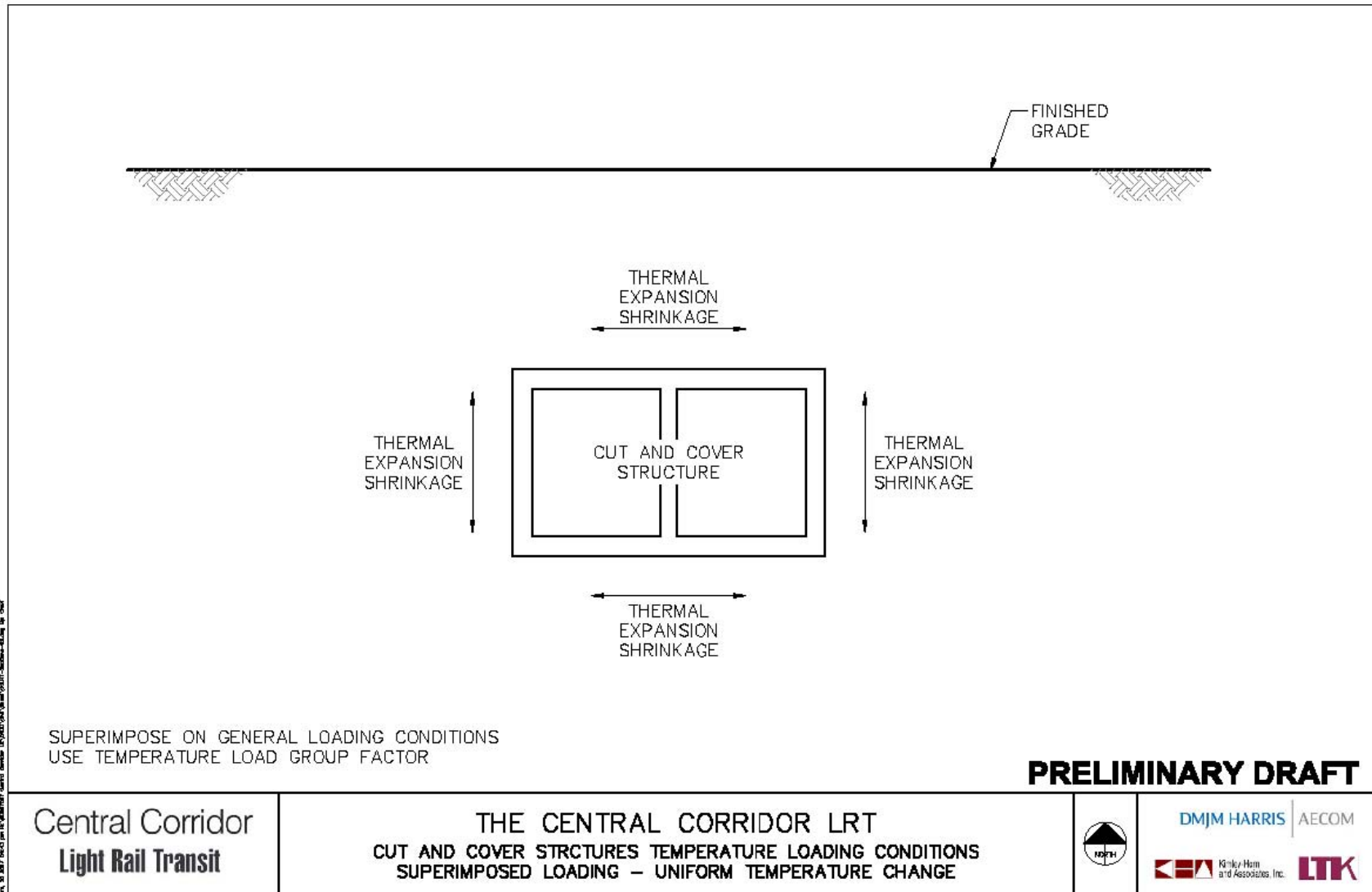

Figure 4.7 – Superimposed Loading – Uniform Temperature Change (TS1).

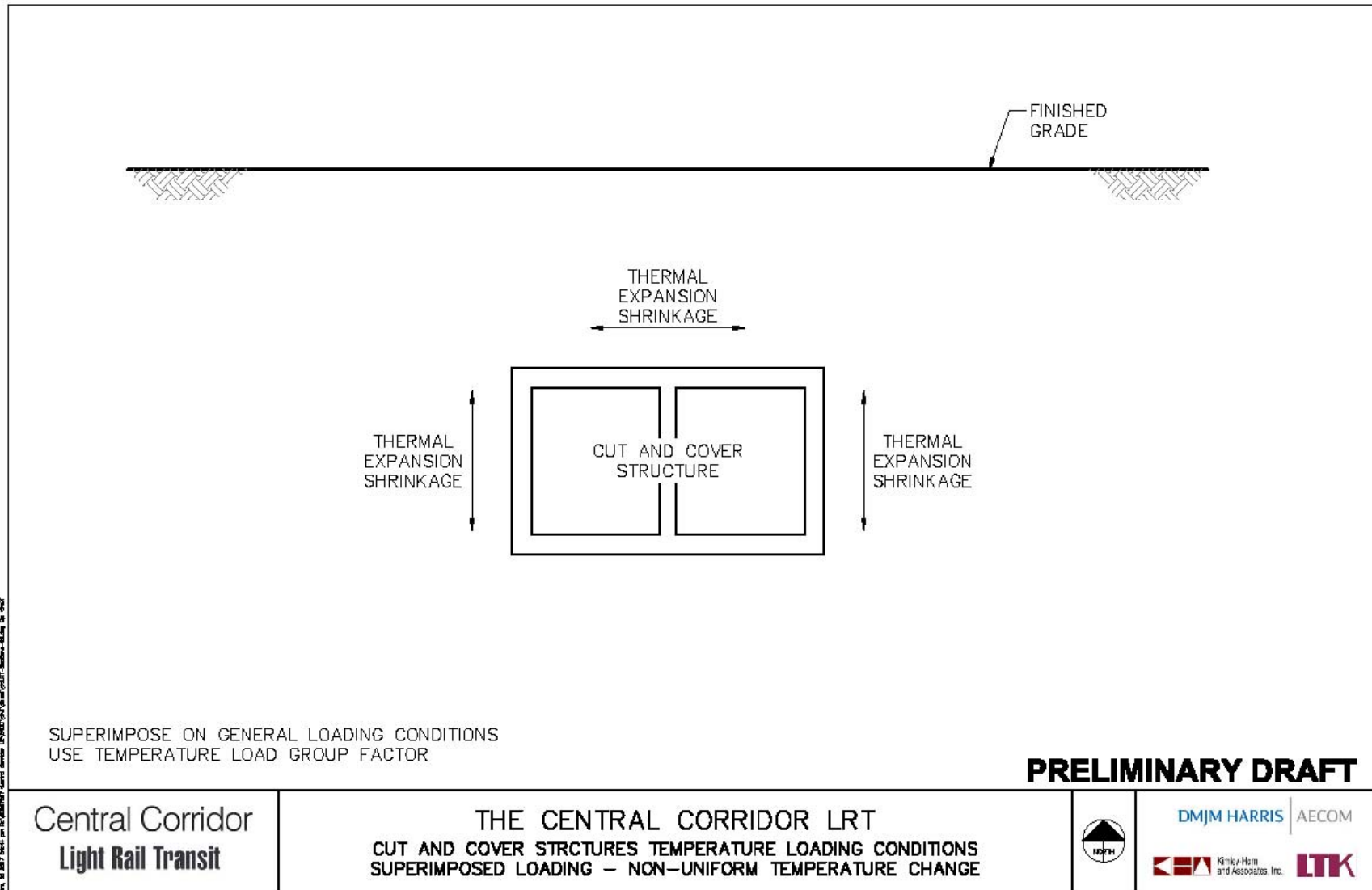

Figure 4.8 – Superimposed Loading – Non-Uniform Temperature Change (TS2).

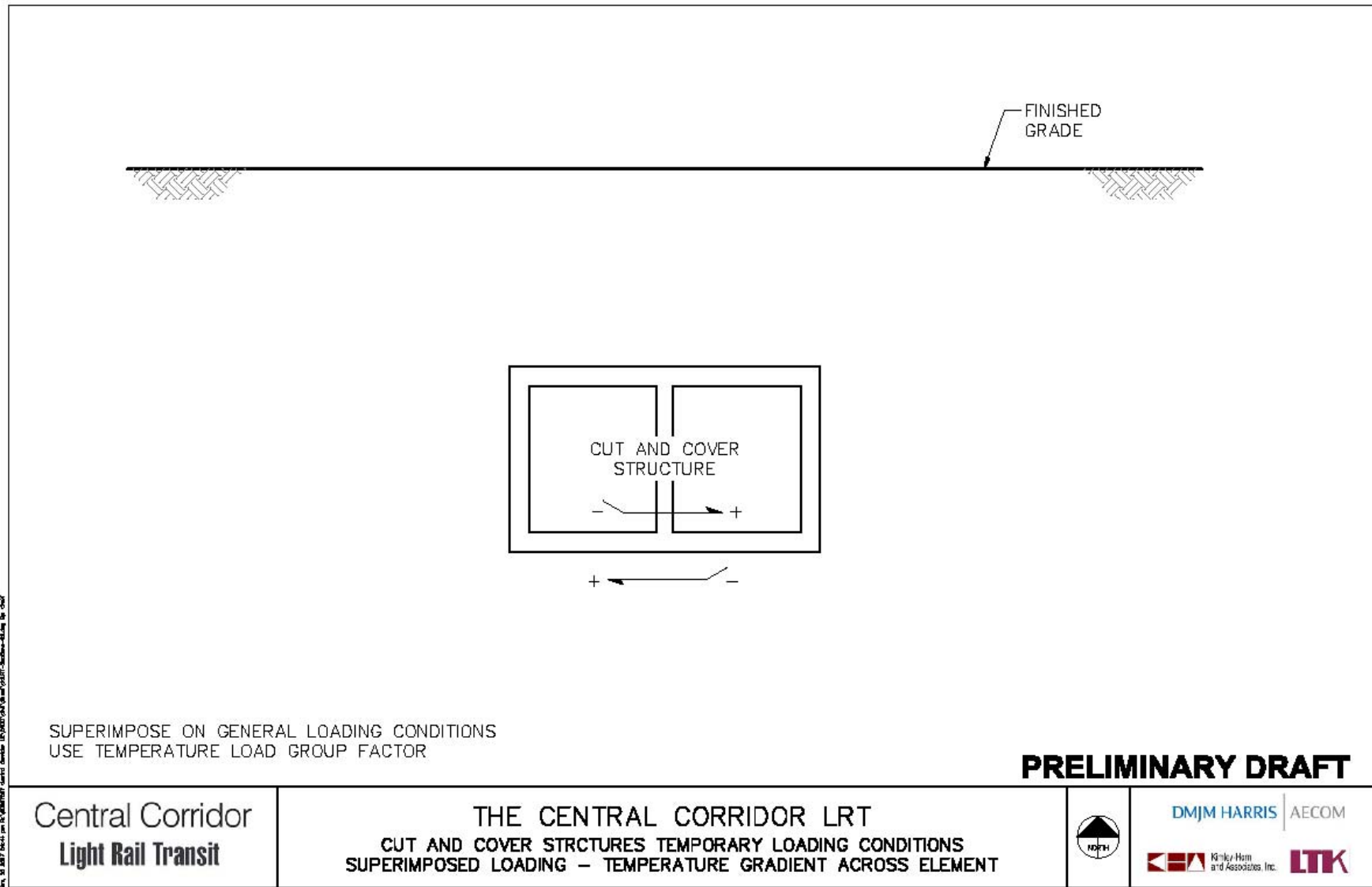

Figure 4.9 – Superimposed Loading – Temperature Gradient Across Element (TS3).

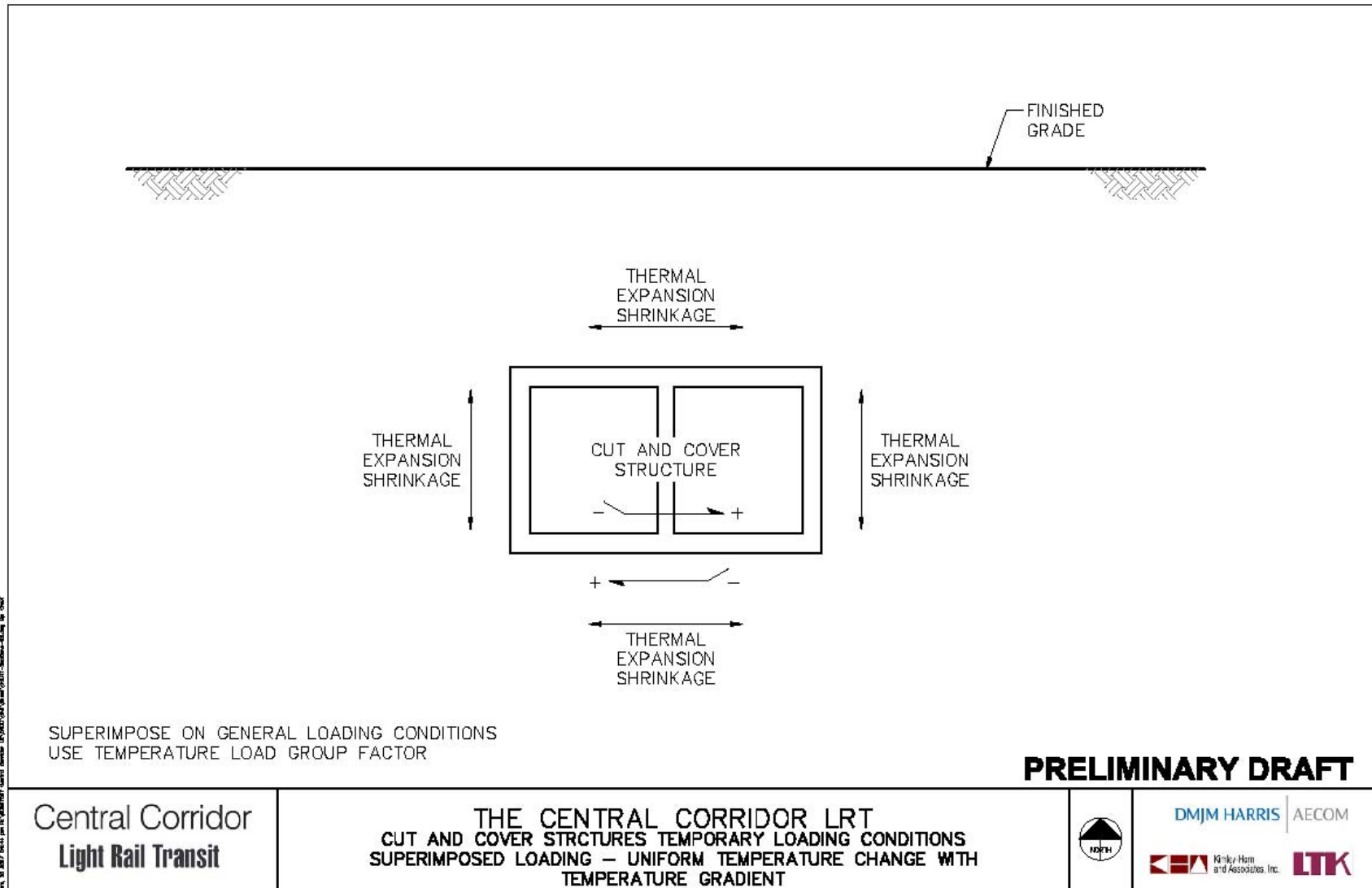

Figure 4.10 – Superimposed Loading – Uniform Temperature Change with Temperature Gradient (TS4).

7.5 ADDITIONAL CONSIDERATIONS

There are additional considerations that the designer must take into consideration. These considerations include buoyancy, bearing capacity, overturning, and sliding of the structures.

7.5.1 Buoyancy

For structures in all stages of completion, adequate resistance to flotation will be provided at all sections for full hydrostatic uplift pressure on the structure foundation based on the probable maximum elevation of the groundwater table.

7.5.1.1 Completed Structure

Resistance shall consist of the dead weight of the completed structure plus the weight of the backfill overlying the structure which is located within the vertical planes drawn through the outer edges of the structure roof and through all joints separating adjacent structural sections. Provision shall be made in the design, or a construction sequence shall be specified, to prevent buoyancy that might result from a rise in the water table before all backfill is placed.

When evaluating buoyancy loads, the weight of street pavement and live load shall be neglected for the purpose of computing the factor of safety against uplift. Sidewall soil friction effects shall be thoroughly evaluated before use in uplift calculations. The required factor of safety against uplift under these conditions shall be 1.10. The factors of safety for the completed sections shall be 1.05 for a 100 yr flood.

7.5.1.2 Partially Completed Structure

The designer shall provide a construction sequence, together with all temporary measures necessary to ensure adequate safeguards against flotation during all stages of construction. Resistance will consist of the dead weight of the completed portion of the structure plus the additional resistance ensured by the safeguards provided by the designer in the construction sequence. Sidewall soil friction effects shall be thoroughly evaluated before used in any uplift calculations. It shall also be evaluated for each application. The required factor of safety against uplift for the partially completed structure shall be 1.05.

Rotational effects due to buoyancy shall be considered where the main structure is markedly asymmetrical. Local asymmetry shall not be considered unless the section is isolated by structural joints.

7.5.2 Bearing

Structures shall be analyzed as continuous structures on elastic foundation. Base pressure shall not exceed the allowable soil bearing capacity. In order to minimize differential settlement and excessive outward tilting of walls, walls shall be

proportioned so that the base pressure on soil under the footing is as nearly uniform as practical under the long term loading.

Where the base pressure exceeds the allowable soil bearing capacity, or where the base pressure produces excessive differential settlement, walls shall be founded on piles, provided that a more economical solution cannot be obtained by changing the wall proportions.

7.5.3 Overturning

Stability against overturning shall be provided through the use of a factor of safety of 2.0. For structures resting on top of rock, a factor of safety of 1.5 shall be used.

7.5.4 Sliding

If at any segment, the opposite two walls are of unequal heights, then the factor of safety against sliding shall be a minimum of:

- a. 1.5 with no passive resistance of the soil.
- b. 2.0 with passive resistance of the soil.

7.6 WATERPROOFING AND DRAINAGE

Provisions shall be made to collect and drain water seeping through the roof, walls or floor for immediate and effective removal of water resulting from rainfall, drainage outlets, groundwater seepage or any other source.

Seepage into the excavation invert shall be estimated using numerical modeling techniques taking into consideration the boundary conditions and the soil stratigraphy. The geotechnical engineer should develop the engineering parameters for use in seepage calculations.

Ground improvement or ground stabilization may be required to minimize groundwater inflow into the construction zone and to minimize the effects of the construction on adjacent structures and facilities. Techniques such as ground freezing, permeation grouting, jet grouting, compaction grouting, spiling, micro piles, root piles and other stabilization measures shall be developed, as needed, in accordance with the any recommendations from the geotechnical engineer.

1. As far as practicable, drainage shall be by gravity flow.
2. Surface Runoff - Open Roof Transition Structure: Intercept all surface storm water runoff before and at the portal entrance to tunnel and transfer storm water to city storm drain. Drainage facilities for the open roof transition structure to be sized for the 50-year Design Storm event.

-
3. Non- Tunnel Surface Runoff: Storm water runoff from surface areas such as parking areas will be intercepted, separate from tunnel related surface drains, and conveyed to existing city storm drains.
 4. Tunnel Runoff: Inclusive of fire flows, subdrains and areaway drains will be collected and transferred to an oil water separator before discharging into the city sewer system.
 5. Minimum pipe slope – slope to provide minimum flow velocity of 2.5 feet/sec at design flow.
 6. Drain inlet requirements – 100 foot maximum spacing.
 7. Manhole requirement – 400 foot maximum spacing.
 8. Implement Best Management Practices (BMPs) inclusive of deep sumps on all inlets, scheduled sweeping and regular inspections on all drainage systems.

7.6.1 Station Structures

7.6.1.1 Roofs and Walls

Station roofs and walls shall be completely waterproofed. Waterproofing and boundary condition details at reglets and flashings shall be provided.

7.6.1.2 Floor Slabs

For station floor slabs, no special waterproofing provisions shall be made where the water can drain freely into the floor drainage system, and where such a leakage and drainage is not objectionable from an operational or visual standpoint; however, drainage shall be provided at public areas of the station floor slab.

7.6.1.3 Ancillary Structures

Differential vertical movements of the station body and its appendages, such as wings or entrances at shafts, due to ground re-expansion as a result of returning of ground water, may cause cracks at joints and other locations. Special attention shall be given to design detailing to mitigate this problem. Where such movements cannot be avoided, properly designed waterproof joints between such appendages and the station body shall be provided.

7.6.2 Line Structures

7.6.2.1 Track Box Structures

Track box structures shall be completely waterproofed. Waterproofing and boundary condition details at reglets and flashings shall be provided.

7.6.2.2 Transition Structure

For depressed transition track structures, where cast-in-place open roof transition structures and retaining walls are used, waterproofing shall be provided at the invert slabs and walls that are exposed to groundwater and shall be extended to a level above the groundwater table. Special attention shall be given to controlling shrinkage cracks in sidewalls between construction joints.

7.6.3 Electrical and Mechanical Facilities

Electrical and mechanical facilities include spaces that house train control facilities, substation facilities, switchgear, ventilation fans, pumps and other equipment.

7.6.3.1 Train Control and Auxiliary Equipment Rooms

Rooms or spaces shall be completely waterproofed, including all surfaces in contact with earth. Waterproofing and boundary condition details at reglets and flashings shall be provided.

7.6.3.2 Substations, Switchgear and Similar Equipment Rooms

Rooms shall be completely waterproofed, including all surfaces in contact with earth. Waterproofing and boundary condition details at reglets and flashings shall be provided.

7.6.3.3 Fan and Pump Rooms

Rooms shall be completely waterproofed, including all surfaces in contact with earth. Waterproofing and boundary condition details at reglets and flashings shall be provided.

7.6.4 Waterstops

Waterstops shall be used in all construction joints in exterior walls, floors and roofs.

7.6.5 Portals and Open Roof Transition Structures

The location of portals and the establishment of the limits of open roof transition structure and retaining walls shall take into consideration the need to provide protection against flooding resulting from local storm runoff.

7.7 FIRE PROTECTION

Structural elements shall be protected from excess heat. At a minimum, sprinkler and standpipe fire protection systems will be employed.

7.7.1 Sprinkler Systems

Sprinkler systems shall include a main water supply, fire department inlet connections, alarm check valve, piping from inlet connections and water supply mains to the sprinkler heads, sprinkler heads (with spares), drain lines, provisions for remote alarm devices, pipe fittings, valves, hangers, inserts, sleeves, and appurtenances. Sprinkler systems shall conform to the requirements of NFPA 13. Dry-pipe sprinkler systems shall be installed in unheated areas and where the provision of freeze protection is not practical.

Where not more than six sprinkler heads are required for any isolated hazardous area, they may be connected to the cold-water piping of the domestic water system having sufficient capacity. If the sprinkler system is designed to connect to the domestic water supply, care shall be taken so that the domestic water flow does not activate the alarm system.

7.7.2 Standpipe Systems

Standpipe systems shall include fire department inlet connections, piping from inlet connections to supply main, hose valves, fire hose cabinets, drain lines, pipe fittings, control valves, hangers, inserts, sleeves, and appurtenances. Standpipe systems shall conform to the requirements of NFPA 14 and NFPA 130.

7.8 SUPPORT AND UNDERPINNING OF EXISTING STRUCTURES

Existing structures must be protected from ground movements and subsequent settlement resulting from excavation and mining activities associated with construction of the project facilities. All existing structures that are supported by structural elements that will be removed or disturbed as part of the project activities shall be underpinned or otherwise temporarily supported while project construction is underway.

Effects of construction on the groundwater table shall be analyzed for impact on adjacent structures, facilities and environmental conditions.

7.8.1 General

The protection of existing structures should be based on the method of excavation support that is used for the structure. The protection of existing structures shall be accomplished by the use of protection walls around the excavation, underpinning the existing structure, or a combination of these two methods. When determining the appropriate method of protection, consideration shall be given to the sequence of construction and the effects of protection placement on other phases of construction and vice versa. Consideration shall also be given to the right-of-way requirements of the different protection method.

The influence of existing structures on excavation activities and the influence of excavation activities on the settlement, and/or rotation and stability of existing structures shall be analyzed and evaluated both from structural and geotechnical standpoints. Evaluations shall be made for all buildings or structures along the project alignment that encroach on or are immediately adjacent to the proposed project structures. In addition to proximity to the proposed project structures, the age, type, use and construction of the existing structures shall be considered. Based on these evaluations, design parameters shall be established for the allowable settlement, differential settlement and rotation of each building affected by excavation or tunneling activities. Also, the allowable horizontal displacement of excavation support shall be analyzed on a case by case basis.

Underpinning of a structure shall be considered only if the estimated movement of the structure, if protection walls were used, would be in excess of that which is allowable. The allowable settlement shall be determined for each structure in conjunction with the building owner. Some settlement is anticipated with most underpinning systems. These settlements shall be taken into account in assessing the effects of construction on the existing structure. Underpinning shall be considered where applicable and required and could include, among others, the following methods:

- Pit piers
- Jacked piles
- Micro Piles
- Column pick-up
- Foundation grouting

In final design, the Contractor shall be responsible for restoration, which shall be defined as the correction by repair or replacement, of structures damaged or altered as a result of construction operations. Restoration shall be required to a condition equivalent to that existing prior to the start of the work.

General requirements for initial appraisal of the need for underpinning are shown on Figure 2.1. As shown in the figure, the area of influence of the construction excavation is divided into three zones designated A, B, and C. In general, structures within Zone A shall require underpinning and all underpinning must develop capacity with the required factor of safety within Zone C. Where building foundations located immediately outside of Zone A carry a load heavy enough to expand the active zone, (Zone A), underpinning shall generally also be required. Foundations of lighter structures that are located within Zone A adjacent to the excavation may not need to be underpinned if the protection wall is designed to carry the loads and movement can be limited to tolerable amounts. Foundations within Zone B generally do not need to be underpinned. In all cases in which foundations falling within Zones A and B are not underpinned, the project structure shall be designed to resist vertical and horizontal pressures resulting from the presence of the foundations.

All heavy structures that encroach on or are immediately adjacent to the project structures shall be underpinned in advance of excavation for the project structures unless the foundations for the existing structures extend below the excavation subgrade and derive supporting capacity below this level. If underpinning is required, foundation loads will be transferred to Zone C through the use of walls or drilled piers, or by various types of driven, jacked or drilled piles. All underpinning members shall be completely independent of the rail structure free standing and isolated from the rail structure in such a manner that transfer of train vibrations to the supported structures shall be minimal.

Lighter structures may be temporarily supported at selected points along the foundation by jacks that can be used to compensate for movement of the structure. When it appears to be economically feasible in the case of minor structures or portions of larger structures, consideration shall also be given to the removal and replacement or subsequent repair of structures in lieu of underpinning or constructing temporary support structures.

7.8.2 Loads and Forces

The loads of each facility to be underpinned shall be calculated by the underpinning designer. If original structural analyses are available, they shall be used as guides in determining the current actual loads and forces to be carried.

7.8.3 Project Conditions

7.8.3.1 Maintenance of Operations

The underpinning activities will be scheduled to avoid impacts to rail operations as much as possible. All impacts on rail operations will be identified clearly during the initial development of the design.

7.8.3.2 Maintenance of Utilities

The need for maintenance of each utility shall be addressed in the design. Where it is determined that a service disruption during construction is desirable, the utility owner shall be consulted and disruption constraints shall be defined.

7.8.4 Monitoring During Load Transfer

Fixed reference points shall be identified prior to initiating load transfer activities. The points shall not be part of the underpinned structure.

8.0 LOW-FLOOR LIGHT RAIL VEHICLE

8.1 GENERAL DESCRIPTION

8.1.1 Car Type

The carbodies shall be low-alloy, high-tensile (LAHT) steel, with selected structural elements of stainless steel, and the cars shall be articulated. The cars shall be of the partial (approximately 70%) low floor type. A minimum of eight passenger doorways, four per side directly across from one another, shall be provided, all in the low floor Section. Each end of the car shall have a fully equipped operator's position. Cars shall be capable of multiple unit operation in consists of up to three cars with emergency operation up to six cars. The anticipated service life of the car is 30 years.

8.1.2 Seating Arrangement

Each car shall have a minimum of 66 seats.

8.1.3 Elderly and Handicapped Accessibility

Space shall be provided in each car to accommodate a minimum of four wheelchairs. The cars shall, in conjunction with coordinated platform configuration, comply with the Americans with Disabilities Act (ADA).

8.1.4 Car Major Equipment Configuration

The car shall have the following major equipment configuration:

- There shall be three trucks per car, a powered truck at each end and a trailer truck under the center body section;
- Propulsion shall use asynchronous three-phase alternating current (AC) traction motors, two per powered truck with parallel drive. There shall be two independent inverter drive systems, one per powered truck. Dynamic braking (rheostatic and regenerative) shall be provided;
- Friction braking shall consist of electro-hydraulic disc braking on all trucks, with an independent friction brake controller for each truck; and
- HVAC shall consist of floor heat, overhead heat, and overhead air cooling. Two independent overhead HVAC units shall be provided, powered from three-phase AC produced by dedicated variable voltage variable frequency auxiliary inverters.

8.2 CRITICAL CAR DIMENSIONS

8.2.1 Carbody Dimensions

Length of car over coupler faces	90 to 94 ft
Length of car over anticlimbers	88 to 92 ft

Width of car at widest point (excluding mirrors)	8.7 to 8.8 ft
Floor height above top-of-rail (AW0)	
• High floor section (maximum)	39 in.
• Low floor section	14 in.
Minimum interior ceiling height, finished floor to finished ceiling, on vehicle centerline	6.7 ft
Side door minimum clear opening width with doors fully opened	48 in.
Minimum clear side door height from finished floor	6.5 ft
Maximum door panel excursion during opening	2.25 in.
Minimum aisle width	25 in.
Maximum roof-mounted equipment height, including roof shrouds, exclusive of pantograph, above Top of Rail (TOR) with new wheels and car at AW0	12.4 ft
Coupler vertical centerline height above TOR, car at AW0, with new wheels	18.5 to 26.6 in.
Top of anticlimber height over TOR, car at AW0, with new wheels	Same as top of high floor
Minimum depth of interior step treads	11 in.
Maximum height of interior step riser	9.85 in.
Maximum low floor height variation above top of rail at doorways, with loads from AW0 to AW4 (sum of air suspension tolerances, car body and truck tolerances, and deflection)	± 0.375 in.

8.2.2 Pantograph Dimensions

Maximum height above TOR of the highest point on the pantograph in the lockdown position, new wheels and car at AW0	12.7 ft
Pantograph operating height, dynamic conditions any car weight AW0 to AW4, and with new to fully worn wheels	Max. 22.3 ft Min. 13.0 ft
Collector head width	16"
Collector head length over horns	78 in.
Distance between carbon shoes	13"-14"
Minimum collector head carbon shoe length	47 in.
Maximum longitudinal distance from truck pivot to center of pantograph shoe, locked down	46 in.
Static pantograph uplift pressure	Max. 25 lbf.

8.2.3 Wheel Dimensions

Profile: The wheel profile shall be as shown on Figure 8-1.

Diameter, motor truck:

New, nominal	26 in. to 28 in.
Minimum allowable wheel diameter wear	2 in.

Diameter, trailer truck:

New, nominal	24 in. to 26 in.
Minimum allowable wheel diameter wear	2 in.

Back-to-Back Dimension 53.80 in.

8.2.4 Truck Dimensions

Truck Spacing, centerline-to-centerline: Sufficient to comply with dynamic envelope.

Truck wheelbase, motor truck	71 in. to 75 in.
Truck wheel base, trailer truck	67 in. to 75 in.

8.3 WEIGHT AND PASSENGER LOADING

The weight of each car, including passengers, where appropriate, at 154 lbs. each, shall be defined as follows:

AW0	Maximum empty car operating weight:	105,000 lbs.
AW1	Full seated load at 67 persons minimum (66 passengers plus operator), plus AW0:	115,300 lbs.
AW2	Standees at 4 persons per m ² suitable standing space per passenger, 120 persons minimum, plus AW1:	133,800 lbs.
AW3	Standees at 6 persons per m ² of suitable standing space per passenger, 180 persons minimum, plus AW1:	143,000 lbs.
AW4	Standees at 8 person per m ² suitable standing space per passenger, 240 persons minimum, plus AW1:	152,300 lbs.

The car weight supported at the center truck at AW0 to AW2 shall be within the range of 25% to 40% of the total car weight.

The difference in supported car weight between the A-End and B-End trucks shall not exceed 2000 lbs, AW0 to AW3.

The lateral imbalance shall not exceed 25,000 in-lbs, AW0 to AW3.

The structural loading requirements of the car shall be as shown in the Structural Loading Diagram, Figure 8-2.

The carbody structure must be designed to withstand a longitudinal load of 2g or as determined by crashworthiness analysis applied at the centerline of the anticlimber without yield.

8.4 CURVES AND GRADES

The car shall operate over:

- Minimum horizontal curve radius 82 ft
- Minimum vertical curve radius, crest 820 ft
- Minimum vertical curve radius, sag 1150 ft
- Maximum gradient 7%

8.5 DYNAMIC ENVELOPE

8.5.1 General

Maximum dynamic roll angle, failed suspension: 3 degrees.

8.5.2 Tangent Track

The dynamic envelope of the car on tangent track at any speed up to 55 mph shall be limited to that shown on Figure 8-3.

8.5.3 Curves

The maximum dynamic offset in curves shall be as shown in Figure 8-4 for details. Refer to Section 2.03.

8.5.4 Undercar Clearances

Vertical undercar clearance is defined from TOR with the maximum suspension deflection and carbody roll, minimum vertical curve radius, and fully worn wheels. Minimum vertical clearance shall be 2 in.

With the above conditions and with any radius horizontal curve down to the minimum, clearances between truck components and the carbody shall be no less than 1.5 in. For trucks that do not swivel under a center carbody section, this clearance may be reduced to 0.5 in.

8.5.5 Station Platform Interface

The station platform interface shall be as described in Sections 2.03.3.3 and 6.03.

8.6 PROPULSION/BRAKING PERFORMANCE

8.6.1 Acceleration

The following acceleration requirements shall be met at car loads from AW0 to AW2. At loads above AW2, the maximum rate may be reduced proportionally by the ratio of AW2 to the actual car weight.

- Maximum acceleration rate 3.0 mphps +5%

Maximum acceleration shall be available from 0 to 20 mph for line voltages 750 Vdc and above. For line voltages between 525 Vdc and 750 Vdc the maximum acceleration shall be available from 0 mph to a speed decreased proportional to line voltage.

- Time to reach 25 mph, AW0 to AW2 (750 Vdc and above) ≤ 10 s
- Time to reach 50 mph, AW0 to AW2 (750 Vdc and above) ≤ 35 s

8.6.2 Service Brake Requirements

The following deceleration requirements shall be met at car loads from AW0 to AW3. At loads above AW3, the maximum rate may be reduced proportionally by the ratio of AW3 to the actual car weight.

Full service brake rate, for speeds from 59 mph Tapered from 2.0 mphps at 59 to 45 mph:

mph to 3.0 mphps at 45 mph

Full service brake rate, for speeds from 45 mph to stop: 3.0 mphps \pm 5%

Braking shall be provided by a combination of dynamic and disc braking. The dynamic brake shall be regenerative and rheostatic.

Dynamic brake fade shall not occur above 6 mph.

In the event of dynamic brake failure, maximum train speed shall be automatically limited to 30 mph $+3/-0$ mph. The disc brake shall be capable of providing the specified rate, with a +15% tolerance, without damage to any equipment or brake pads, for a complete round trip on the LRT line.

8.6.3 Emergency Braking Requirements

For brake entry speeds equal to or greater than 30 mph, the minimum emergency brake rate, at all weights up to AW3, shall meet or exceed the values calculated by the following equation:

$$RAV \text{ [mphps]} = -0.02v \text{ [mph]} + 5.6$$

Where RAV is the average emergency braking rate in mphps and v is the brake entry speed in mph. The maximum emergency braking rate shall not exceed the minimum rates by more than 30%.

For brake entry speeds greater than 15 mph and less than 30 mph, the average emergency brake rate shall be a minimum of 5.0 mphps and shall not exceed this rate by more than 30%.

For brake entry speeds of less than 15 mph, the instantaneous emergency brake rate after the rate has built up shall be a minimum of 5.0 mphps and the maximum rate shall follow the characteristics of the magnetic track brake.

8.6.4 Parking Brake

The parking brake system shall be capable of holding a car to AW4 on a 7% grade indefinitely.

8.6.5 Continuous and Balancing Speed

Minimum balancing speed: provide minimum residual
(AW0 to AW2, level tangent track.) of 0.5 mphps at 55 mph

Balancing speed on a 5% uphill grade: 40 mph
(AW0 to AW2, tangent track)

Minimum safe operating speed: 65 mph
(fully worn wheels)

The car shall be capable of operating at speeds of 5 mph or less for 20 minutes at AW2 without overheating or damage to any components..

8.6.6 Mode Change Dead Times

Mode change dead time shall not exceed the following:

- Power to Brake 200 ms
- Power to Coast 200 ms
- Coast to Brake 200 ms
- Coast to Power 200 ms
- Brake to Power - below 3 mph 200 ms
- Brake to Power - above 3 mph 400 ms

8.6.7 Jerk Limits

In response to a step input command signal, the average rate of change of acceleration or deceleration in full service brake or maximum propulsion mode shall be the following:

- Minimum 2.5 mphps²
- Maximum 3.0 mphps²

Emergency brake applications shall not be jerk limited.

8.6.8 Spin/Slide Correction

A system shall be provided to detect and correct wheel spin and slide on each car whether random or synchronous on an individual truck basis both in acceleration and braking.

The spin/slide system shall detect slides or spins by evaluation of axle or wheel speed differences and acceleration/deceleration rate levels. A separate safety timing function shall be provided to trip and override friction brake release on each truck after 3 s from slide detection if the braking effort on the truck remains below 25% of the commanded value for more than that time period.

Efficiency shall be at least 90% in acceleration and in braking.

8.6.9 No-Motion Detection

Apparatus shall be provided to detect, in a vital manner, all vehicle motions down to and including 2 mph.

8.6.10 Duty Cycle Rating

The car shall be capable of continuous operation on the light rail line without exceeding the continuous rating of any equipment, under the following conditions:

- A constant AW2 load;
- dwell time of 8 s at each stop;

-
- Acceleration and braking at maximum service rates;
 - Operation to maximum track speeds; and
 - A 30 s layover at each end of the line.

In addition, one train with an AW3 load shall be capable of pushing or towing another train of equal length with an AW3 load from the point of failure to the next station, where passengers would be unloaded, and then continue with both trains at AW0 load to the end of the line, at reduced performance, without damage or reduction in equipment life. The point of failure shall be considered to be at the farthest location on the line from either end of the line such that the worst load is imposed on the equipment. The train will be dispatched to the nearest end of the line. The train operating in this condition would be operated as a special equipment movement with no passenger station stops after the first and would slow down only as normally required by other traffic, signals, and civil requirements. In this scenario, maximum speed is reduced to 30 +3/-0 mph.

8.6.11 Compensation for Car Load

Acceleration and braking tractive effort shall be adjusted to compensate for car load to provide the acceleration and braking rates specified in the prior parts of Section 8.0 to be maintained constant as the car load varies. The failure mode will be to indicate AW0 car weight. The specified rate shall be provided when the car is operating on level, tangent track; there shall be no compensation for grade or curve resistance. Schemes that use rate feedback shall not be allowed.

8.6.12 Load Leveling

An active secondary suspension shall be provided which shall maintain a constant floor height above top-of-rail for all car loads AW0 to AW4.

8.7 SYSTEM OPERATIONS

8.7.1 Line Voltage

The car shall be designed for the following line (overhead contact system) voltage conditions:

- Nominal: 750 Vdc;
- Maximum sustained: 900 Vdc;
- Minimum sustained: 525 Vdc; and
- DC derived from 12 pulse rectification

The equipment shall operate over the range of 525 Vdc to 925 Vdc without damage, failure to function as specified, or reduced service life. All equipment shall be impervious to damage on any continuous voltage from 0 to 950 Vdc. Low voltage cut-out of any system shall be at or below 525 Vdc. High voltage cut-out shall be at or above 925 Vdc.

8.7.2 On-Board Voltages

Low Voltage Power System: 28.5 or 37.5 Vdc

AC power supplies: 208/120 Vac rms, 3 phase, 4 wire, 60 Hz., and variable voltage variable frequency 3 phase, 3 wire for specific motor loads with Metro Transit approval.

8.7.3 Electromagnetic Interference

8.7.3.1 Radiated Emission Limits

From 0.01 MHz to 30 MHz, the maximum permissible interference limit shall not exceed 20 dB above the limit of Figure 22 (RE05) of MIL-STD-461A.

From 30 MHz to 88 MHz, the maximum permissible interference limit shall be 58 dB above one $\mu\text{V}/\text{m}/\text{MHz}$ bandwidth.

From 88 MHz to 3000 MHz, the maximum permissible interference limit shall be 68 dB above one $\mu\text{V}/\text{m}/\text{MHz}$ bandwidth.

8.7.3.2 Conductive Emission Limits

The following may be modified depending on signal system requirements:

- From 0 Hz to 40 Hz, 10 A maximum.
- From 40 Hz to 120 Hz, 1 A maximum.
- From 120 Hz to 320 Hz, 10 A maximum.
- Above 320 Hz, the emissions limit then follows a smooth curve through 10 A at 320 Hz, 0.08 A at 2 kHz, 0.016 A at 4 kHz and 0.0046 A at 7 kHz.

8.7.3.3 Inductive Emission Limits

The following may be modified depending on signal system requirements:

- The inductive emissions shall be limited to a maximum of 20 millivolts (mV), rms, rail-to-rail, at all frequencies between 20 Hz and 20 kHz.

8.7.4 Audible Noise

Interior noise shall not exceed the following:

Car stationary:	72 dBA
Car operating on tangent track (any speed):	78 dBA

Exterior noise, measured 50 ft from the centerline of the track, 5 ft the above ground, shall not exceed the following:

Car stationary:	68 dBA
Car operating on tangent track (any speed):	75 dBA

8.7.5 Shock and Vibration

Vibrations anywhere on the car floor, walls, ceiling panels and seat frames shall not exceed the following:

Below 1.4 Hz: Maximum deflection (peak to peak):	0.10 in.
1.4 Hz to 20 Hz: Peak acceleration :	0.01 g.
Above 20 Hz: Peak velocity	0.03 in./s

All vehicle equipment shall operate without damage or degradation of performance when subjected to vibration and impact encountered during normal service, and shall be compliant with and tested per IEC 61373 standard, including all functional and durability requirements.

8.7.6 Ride Quality

The rms acceleration values shall not exceed the "4-hour, reduced comfort level (vertical)" and "2.5 hr, reduced comfort level (horizontal)" boundaries derived from Figure 2a (vertical) and Figure 3a (horizontal) of ISO 2631 over the range of 1 Hz to 80 Hz, for all load conditions AW0 to AW3.

8.7.7 Flammability and Smoke Emission

All materials used in the construction of the car shall meet the requirements of the U.S. Department of Transportation's "Recommended Fire Safety Practices for Rail Passenger Car Materials Selection - January 1989".

The floor structural assembly shall meet a 30 minute minimum endurance rating if tested in accordance with ASTM E 119. The ceiling structural assembly shall meet a 15 minute minimum endurance rating if tested in accordance with ASTM E 119.

Total BTU content shall be no more than 90,000,000 BTUs per car. Heat release rate shall be no more than 45,000,000 BTUs/hr per car.

8.8 RELIABILITY

The Mean Distance Between Train Delays (MDBTD) of the car, defined as total accumulated miles divided by total number of relevant failures, shall be:

Car MDBTD \geq 25,000 miles

Individual systems shall meet the following Mean Distance Between Component Failures (MDBCFC) reliability requirements:

System	MDBCFC (miles)
Traction Equipment & Controls	50,000
Friction Braking	50,000
Communications	75,000

Side Doors & Controls	85,000
Lighting	350,000
Auxiliary Electrical Apparatus	100,000
HVAC	100,000
Couplers & Draft Gear	100,000
Trucks & Suspension	170,000
Train-to-Wayside Communications	170,000

8.9 MAINTAINABILITY

The car shall be designed to minimize Mean Time To Repair (MTTR). The quantitative maintainability goal for the car shall result in an overall MTTR of 1.8 hours. This shall be the average of the MTTR of the key system elements as listed below. Diagnostic time shall be included in MTTR.

System Element	MTTR (hours)
Traction Equipment & Controls	1.8
Friction Braking	2.0
Communications	1.0
Side Doors & Controls	0.8
Lighting	0.5
Auxiliary Electrical Apparatus	1.5
HVAC	2.1
Couplers & Draft Gear	2.6
Trucks & Suspension	1.6
Automatic Train Stop	1.0
Train To Wayside Communication	1.0
Carbody and Appointments	2.1

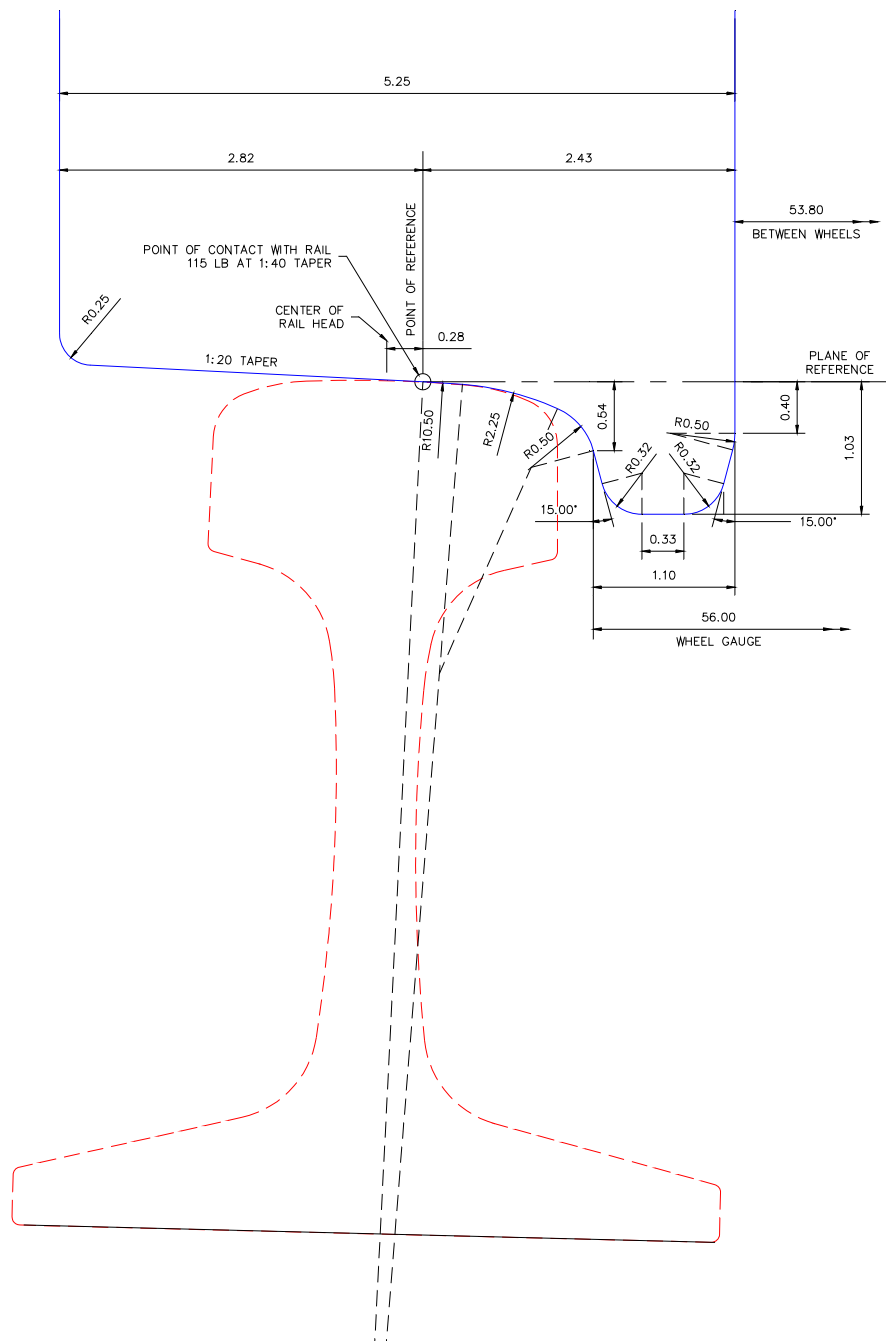

Central Corridor Light Rail Transit

Figure 8-1

Design Criteria

WHEEL PROFILE

NOTE:
 VERTICAL LOADS WOULD BE APPLIED AT
 CENTER OF EACH TRUCK AS SHOWN
 BELOW FOR AWO & AW4 LOAD & DISTRIBUTION.

		LOCATION	% DISTRIBUTION	WEIGHT (lb)
AWO WEIGHT (105,000 lbs)	W ₁	MOTOR TRUCK	30% - 38%	31,500 - 39,900
	W ₂	CENTER TRUCK	25% - 40%	26,250 - 42,000
	W ₃	MOTOR TRUCK	30% - 38%	31,500 - 39,900
AW4 WEIGHT (152,300 lbs)	W ₄	MOTOR TRUCK	30% - 38%	45,690 - 57,874
	W ₅	CENTER TRUCK	25% - 40%	38,075 - 60,920
	W ₆	MOTOR TRUCK	30% - 38%	45,690 - 57,874

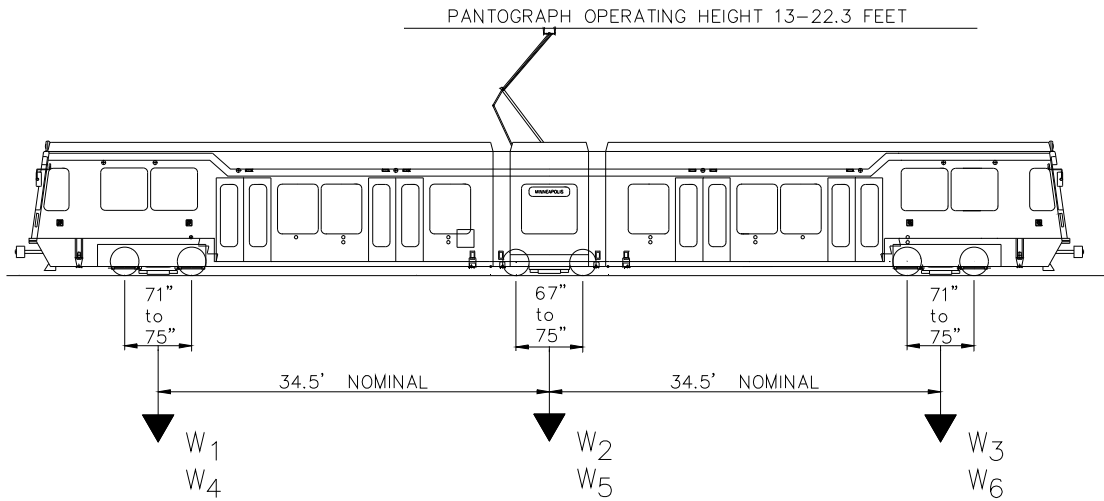

Central Corridor Light Rail Transit

Figure 8-2

Design Criteria

**STRUCTURAL LOADING
 DIAGRAM**

CONDITIONS:

1. MAXIMUM ROLL, FAILED SUSPENSION
2. WORST CASE VEHICLE CONSTRUCTION TOLERANCES
3. WORST CASE COMBINATION OF END TRUCK AND CENTER TRUCK SUSPENSION, CAR BODY, AND TRUCK MOTIONS
4. LEVEL TANGENT TRACK
5. NEW WHEELS AND RAILS
6. NOMINAL RAIL GAUGE
7. PANTOGRAPH LOCKED DOWN
8. LATERAL MOTION COMPRISED OF:

WHEEL GAUGE	.08 IN
NOMINAL SIDE PLAY	.40 IN
LATERAL SUSPENSION	1.33 IN
TOTAL:	1.81 IN

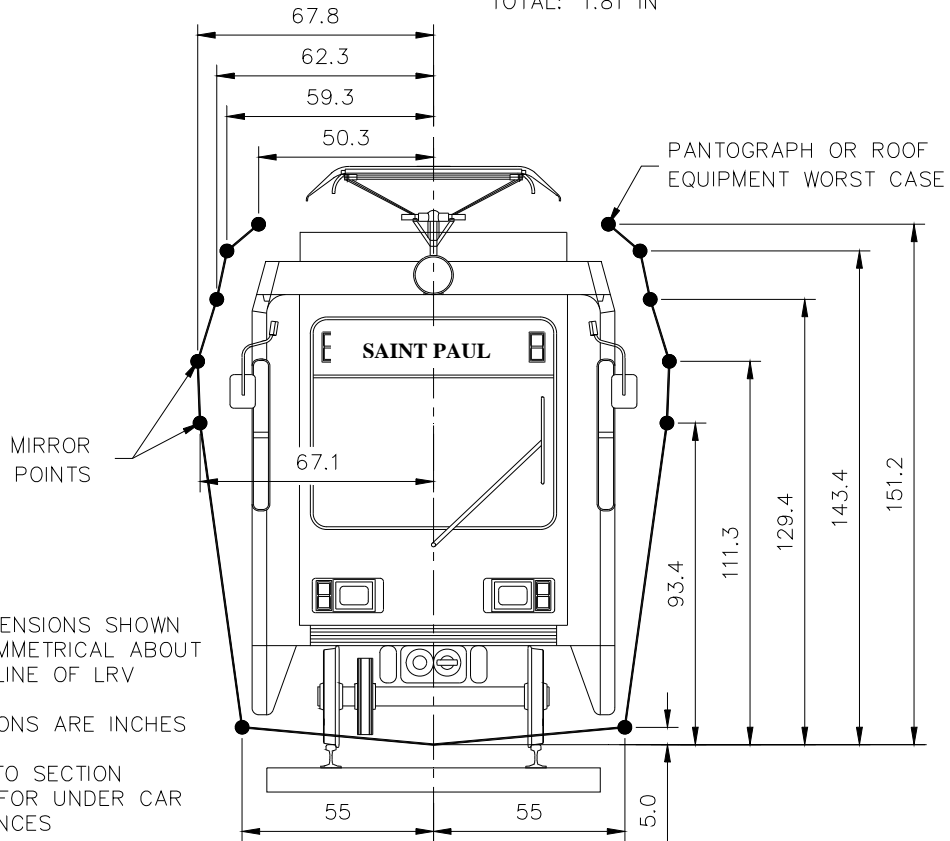

NOTES:

1. ALL DIMENSIONS SHOWN ARE SYMMETRICAL ABOUT CENTERLINE OF LRV
2. DIMENSIONS ARE INCHES
3. REFER TO SECTION 2.3.5.1 FOR UNDER CAR CLEARANCES
4. OFFSETS SHOWN ARE CAR RELATED ONLY FOR CIVIL & WAYSIDE RELATED OFFSETS, REFER TO THE CLEARANCE TABLES LOCATED IN THE APPENDICES

Central Corridor Light Rail Transit

Figure 8-3

Design Criteria

CAR DYNAMIC ENVELOPE

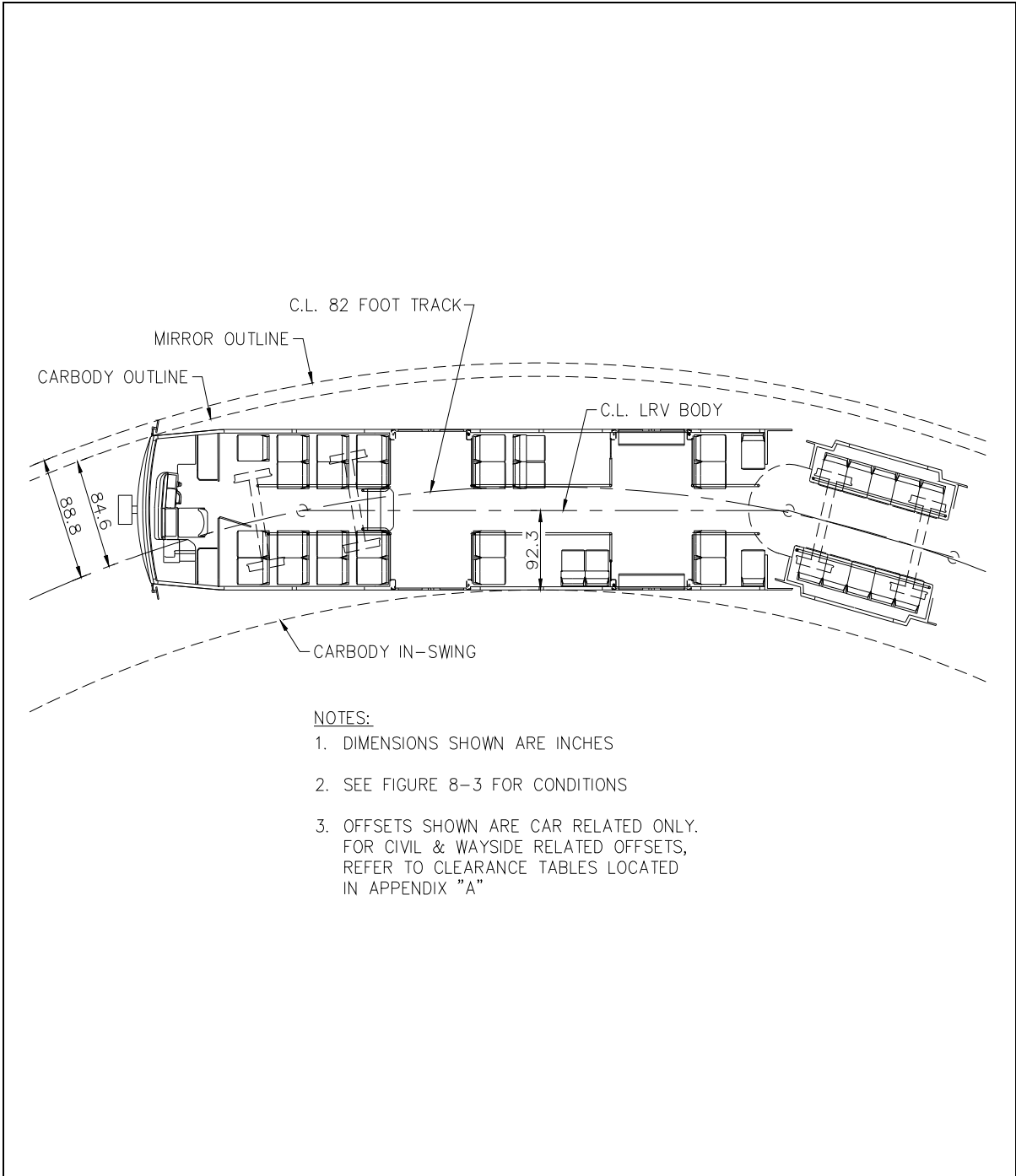

Central Corridor Light Rail Transit		Figure 8-4
Design Criteria	MAXIMUM CURVE OFFSETS	

9.0 OPERATIONS AND MAINTENANCE FACILITY

9.1 DESIGN REQUIREMENTS AND GUIDELINES

9.1.1 Design Codes and Standards

Design requirements for the shop and yard shall comply with the current Minnesota State Building Code and all laws, ordinances, rules, regulations and lawful orders of any public entity bearing on the performance of the work. As of December, 2007, listed below are the principal applicable codes:

2007 Minnesota State Building Code including in part:

Chapter 1307- Elevators and Related Devices
Chapter 1341- Minnesota Accessibility Code
Chapter 4715- Minnesota Plumbing Code

And, the following codes adopted within the Minnesota State Building Code:

- 2000 International Mechanical and Fuel Gas Codes;
- 2005 National Electrical Code;

Metro Transit has adopted a fire and life safety code “Light Rail Transit, Fire Life Safety Code, that is incorporated into these criteria as Section 2 and has requirements pertaining to this Section.

9.1.2 Design Goals

The goals for the design of the Operations and Maintenance Facility(ies) will be established based on an Operational review of the existing transit system and the proposed system and the establishment of a specific program for this facility.

A facility program will be approved by Metro Transit after this review, hereafter referred to as the GUIDE.

The following criteria are generalized for a stand alone, complete Operations and Maintenance facility. Of the functions that are identified, all may not be required.

9.1.3 Exterior Materials

The exterior materials to be used on the facility are to be selected based on durability and appearance. Metro Transit desires a facility that will provide low maintenance over the years, but also provide a pleasing appearance to fit in to the existing area. Materials such as brick, concrete block, pre-cast concrete, and metal siding shall be used.

Glazing shall be double or triple pane insulating glass. Where exposed to direct sun, energy efficient (low “e”) glass shall be used. Exterior wall and roof areas are to be insulated to meet current energy codes. Roof materials

shall be selected based on long-term durability and appearance. Flashings are to be either stainless steel or galvanized. Door and window frames are to be painted metal or aluminum.

9.1.4 Interior Materials

The emphasis on material selection for the interior of the facility is on durability and low maintenance. The shop areas shall be designed for industrial use.

Finishes should be as follows:

Sealed concrete floors in shop areas;

Wall areas in shops to have a minimum 8 ft. high concrete or concrete block wainscoting;

Finished Hallways to be constructed of burnished block or other approved finish with maintenance and durability as a primary design consideration.

Office areas to be metal stud and 5/8 in. gypsum-board construction. Floor and ceiling materials appropriate with use. Sound insulation shall be provided between adjacent office spaces;

Toilet/shower areas to have ceramic tile floor and wall finishes from floor to ceiling; and

Bath and shower facilities to have ceiling grids constructed and installed without painted surfaces, designed with maintenance and corrosion protection in mind.

9.1.5 Structural

The following structural criteria shall be followed:

- Seismic Zone 0;
- Roof load in accordance with Minnesota State Building Code. Snow loading conditions for the County in which the facility is located must be included;
- Floor Loads: 50 psf uniform load at office areas, 125–250 psf uniform load at structured shop storage; Establish concentrated load based on the specific equipment or use; no less than the code minimum.
- Slab on grade: HS-20 Highway loading;
- Wind loads: 80 mph; and
- Soil bearing pressure to be verified with geotechnical report.

The building structure shall be of concrete or steel, Type I or II, fire resistant construction. Use of wood should be avoided.

9.1.6 Lighting

- General light levels shall be as follows:

-
- Shop Areas 50 fc
 - Roof Access Platforms 50 fc
 - Pit Area 100 fc
 - Storage Areas 25 fc
 - Office Areas 25 fc ambient with additional task lighting

- Lighting for specific task areas to be located and designed to meet task requirements;
- This criterion will not limit the proposal and use of new technology, nor is it meant to prescribe outdated and inefficient technology. The lighting design will consider economy, durable and adequate traditional and modern lighting technologies to achieve industry best lighting for the shops, offices or pits.
- Energy-saving lighting systems and fixtures to be used where possible;
- Natural light from windows and clerestory windows shall be maximized to reduce dependence on light fixtures during daylight hours; and
- Pits shall have lights along both sides aimed upward for undercar lighting with a second lens on the bottom for floor lighting.

9.1.7 Corrosion Control and Safety Grounding

The maintenance facility shall have an equipotential grounding system for all conductive surfaces exposed to human contact. This shall be accomplished through use of a building perimeter ground. The perimeter ground shall be bonded to intermittent ground rods and bonded to the metal structure of the building and reinforcement bars of the concrete. The reinforcing steel of the main shop floor shall be bonded into a grid pattern and all shop conductive surfaces shall be bonded to the grid. The shop trackwork shall be continuous and bonded to the grid. The shop grid and perimeter ground shall be bonded to the shop substation ground mat. Insulated rail joints shall be located in the ends of the concrete aprons, which will define the extent of the shop grounding system.

DC stray currents are prevalent in the yard and shop area. Accordingly, ferrous pipe shall be coated with an electrical insulating material and tested prior to burial. Some underground services (such as natural gas) may be better served by use of plastic pipe where the code allows. Joints in piping will require bonding in some locations and insulated joints in others. Refer to the Chapter 14 of these Criteria.

9.1.8 Acoustics

In planning the new facility, noise-generating equipment such as air compressors, wheel truing machine and pumps shall be located away from office areas and/or acoustically isolated. HVAC mechanical units shall be located and specified so that noise and vibration transmission is minimized.

In addition, walls, ceilings and floors in these spaces shall be insulated to further reduce noise transmission to other parts of the facility.

9.1.9 Maintenance

In planning the new facility, Metro Transit's proposed maintenance procedures shall be reviewed and staff Operations personnel shall be consulted to ensure that the new facility provides an efficient work environment. Janitorial closets and other maintenance rooms shall be located on each floor and in locations convenient for users. Floor drains, hose bibs, etc. shall be located for convenience of use.

9.1.10 Mechanical and Plumbing Systems

Shop areas shall be heated with a gas-supplied, radiant heat system. The heating system shall be designed in zones. Maintenance pits shall have a section of wall-mounted hot water radiant heat. Pit areas shall have exhaust air ducts at side walls. Shop compressed air shall be available in all pits, roof access platforms and other maintenance locations at convenient intervals to operate tools.

Provide heating for the LRV Storage Building to maintain an average temperature of approximately 50 degrees F in the building during winter months, with all overhead and man doors closed.

Provide pre-formed trench drains at interior of maintenance shop building and LRV Storage Building located in front of all exterior doors with connection piping between all drains. on each side of building (north and south walls).

Control systems for environmental installations will be designed to offer "zones" to heat or cool logical shop areas efficiently and comfortably. The environmental Control systems will be non-proprietary and accessible as part of the overall Metro transit systems control and monitoring scheme.

Control systems for Elevators will be non-proprietary and accessible as part of the overall Metro transit systems control and monitoring scheme.

Office and administration areas shall have forced air heating, ventilating, and air conditioning systems. The HVAC system shall be designed in zones appropriate for use and exposure to heating and cooling loads and demands. The signals equipment room, shop substation, electrical rooms and the Central Control equipment room shall be air conditioned to handle heat loads generated by the equipment.

Control systems will be non-proprietary and must be compatible with all Metro Transit systems.

9.1.11 Access for the Mobility Impaired

The facility shall be designed to meet applicable federal, state and local codes for accommodating access for the mobility impaired in effect at the time of facility design.

9.2 FUNCTIONAL REQUIREMENTS

The Maintenance and Operations Facility may house the following functions:

- Light Rail Vehicle (LRV) storage;
- Train make-up and yard dispatch;
- LRV adds and drops;
- Train operator report area;
- Fare inspection offices and report area;
- Operator and maintenance training;
- LRV service and inspection;
- LRV interior and exterior cleaning;
- LRV air-conditioning, current collector and resistor unit repair;
- Component repair and rebuild;
- TES overhead service and inspection;
- Rail-bound equipment storage;
- LRT parts storage;
- Rail transportation administration;
- Rail maintenance administration;
- Rail operations planning;
- Rail maintenance engineering;
- Central Control;
- LRT training ;
- LRV body shop;
- LRV paint shop;
- Machine & sheet metal shops;
- Wheel truing;
- Wheel & axle pressing;
- LRV truck maintenance, repair & overhaul;
- Electronic component repair;
- Fare collection equipment component repair;
- Communications equipment component repair; and
- Fire/Life/Safety.

If required, the Maintenance-of-Way Facility may house the following functions:

- Signal system service and inspection;
- Traction electrification system (TES) service and inspection;
- Light Rail Transit (LRT) track maintenance;

-
- Station cleaning;
 - Facilities maintenance;
 - LRV re-railing ;
 - Signal relay inspection & calibration; and
 - Covered and open storage of LRT maintenance-of-way (MOW) materials.

9.3 SITE PLANNING

9.3.1 Facilities

The operations facility layout may include:

- Yard:
 - Covered LRV storage area;
 - LRV run around track with full looping capability;
 - LRV cleaning area;
 - Parking, service and access roads;
 - Outside storage area for MOW, traction power and signal equipment;
 - Fire protection system;
 - Yard lighting;
 - Security;
 - Refuse/recycling collection locations;
 - Landscaping; and
 - Fencing;
- LRV main shop;
- LRV exterior wash and dry facility;
- LRV interior cleaning facility;
- Traction power substation; and
- Maintenance-of-way maintenance and storage building.

For track, traction power, OCS, and signals criteria, see separate chapters.

9.4 YARD

9.4.1 LRV Storage Area

Sufficient storage tracks shall be provided to accommodate the fleet as identified in the Operational analysis.. The storage yard shall be arranged to provide space for all LRVs to be stored on level tangent track in two car trains. Area around train storage should be level to facilitate safety of workers moving around trains. The yard storage area shall accommodate a fully enclosed insulated, lighted, ventilated storage building to accommodate storage of the entire fleet.

Alternate tracks in the LRV storage yard (building) shall be provided with paved access aisles between the tracks. Accordingly, track centers shall be

14'-0" where no aisle is required, and 19'-0" where a paved access aisle is required. OCS for the yard shall be supported from the storage building structure inside the building and from OCS poles outside the building structure. Yard lighting shall be provided using a combination of lighting poles and building mounted fixtures.

The layout of the storage yard shall enable movement of LRVs to and from the shop, other yard facilities, and the mainline with the smallest possible number of reverse movements and crossovers, consistent with site space and budget limitations. This shall be accomplished by avoiding the use of stub-end tracks and by proper relationship of yard track orientation to the mainline.

9.4.2 LRV Run Around Loop

A run-around track shall be provided. This track shall provide unimpeded circulation around the yard (outside the storage building), enable LRVs to enter the storage tracks from either end, enable LRVs to enter either end of the shop, allow an alternate exit/entrance from and to the main line, and allow LRVs to reach or bypass cleaning and inspection areas.

9.4.3 Parking

Parking or provisions for future parking shall be provided for visitors and employees to a level adequate to accommodate the parking needs of the two largest shift changes. Access for truck delivery, including trucks with semi-trailers, shall be provided.

Service roads shall be provided around the shop, between selected LRV tracks, and to outdoor storage areas within the yard.

9.4.4 MOW Maintenance and Storage Building

Maintenance, repairs and inside storage for track, signals, traction electrification and buildings and grounds (station components) will be provided. Accommodations will be made for service and repair of large components such as shelter parts, benches, railings, trackwork components, etc. The building will be self sufficient providing for MOW employee needs such as lockers, lunch room, rest rooms, etc.

9.4.5 Outside Storage Areas

Outside storage space shall be provided for the storage of the following types of equipment and structures: OCS poles and OCS hardware, signal equipment, lighting poles, rail, ties, special trackwork (such as switches, switch stands, frogs, etc.), other track materials (such as tie plates, spikes, joint bars, insulated joints, etc.), ballast, and reels of wire. Locations of these types of storage areas are not generally critical and can be fit in, as the track layout is refined. Storage areas shall meet local criteria for land use.

9.4.6 Fire Protection System

Fire protection utilities such as hydrants, sprinklers in the building, and extinguishers shall be provided in accordance with local Fire & Rescue requirements in effect at the time of construction of the facility. The hydrants shall be located so as not to block the movement of LRVs when fire hoses are being used.

9.4.7 Yard Lighting

The yard outside of the storage building shall be illuminated to provide a safe working environment for ultimate 24-hour operation of the facility. The lights shall be automatically controlled by a photoelectric cell. Yard lighting shall be provided to a level of 22 LUX average, 4:1 average to minimum, and 9:1 maximum to minimum for the entire site. Lighting shall be shielded so as not to spill on to neighboring properties. Some illuminated signage shall be required for yard entrance, building entrance and track numbers at building doorways, etc.

9.4.8 Security

Operations facility security shall be achieved by fencing the periphery of the yard and by lighting. The fences shall be in accordance with zoning and permitting limits between 6 and 10 ft in height and of the chain-link type. Gates shall be provided at all yard track and road accesses and shall provide for minimum interference to LRV movement. Sliding gates shall be used. Security lighting shall be placed as necessary to supplement the normal area outside work lighting. A security system, compatible with the Metro Transit Central Control System, shall be installed.

9.4.9 Refuse/Recycling Collection

Refuse collection and recycle bins, dumpsters, etc. shall be provided at several locations convenient to work areas as well as to collection vehicles. Space allocation limitations associated with the shop and yard storage building may require the transfer of waste materials from local collection points to a central location.

Certain containers shall be designated for recycling purposes, such as those used for metal waste, and for office waste paper, cardboard, glass, etc.

The central location will include a waste compactor sized to accommodate the anticipated need of the waste collection activity.

9.4.10 Landscaping

Landscaping shall be minimal, but meet local Land Use requirements. The amount and type shall be consistent with the local development requirements

for the site and the harsh Minneapolis winters. Low maintenance ground cover material (gravel, barkdust, etc.) shall be provided on areas of the site not used for structures, track, or access roads and walkways.

9.5 LRV MAIN SHOP

9.5.1 LRV Shop Functional Requirements

The following general LRV maintenance functional requirements are potential functions for the shop. The final determination of functions shall dictate the types of service and repair facilities to be provided:

- Service, remove & replace car pantograph assemblies, and brake resistors;
- Service, remove & replace car air-conditioning units;
- Exchange of trucks;
- Exchange of defective components with new or rebuilt parts;
- LRV modifications;
- Repair of miscellaneous system equipment and components;
- Running repair;
- Periodic maintenance;
- Air-conditioning unit secondary maintenance and overhaul;
- Safety inspections;
- Interior and exterior cleaning;
- Sand box filling;
- Loading/off-loading equipment to/from rail bound equipment;
- Truck rebuild;
- Wheel truing;
- Body repairs;
- Painting of LRVs;
- Component rebuild;
- Sheet Metal Work;
- Machine Work; and
- Wheel and Component replacement on axles.

9.5.2 LRV Shop Layout

The shop layout shall follow certain design guidelines as closely as funds and site configuration permit. These guidelines relate to the relative location of spaces to each other within the shop, areas of the spaces for the type of activity or function, utility requirements, etc.:

- Proximity to mainline and storage yard will minimize switching movements and facilitate emergency repairs;
- Run-through tracks in the shop area to provide for efficient flow of LRVs and will allow entry and exit from either end of the building;

-
- A maximum of 2 linear car positions in the shop to preclude entrapment of an LRV between others when maintenance and repairs are being performed;
 - Grouping related maintenance and servicing activities to simplify supervision and work-flow, and to help minimize the floor space needed for circulation to and from the various interrelated spaces;
 - Proximity of support activities and proper industrial engineering shall be incorporated to maximize circulation efficiency
 - Fixed and portable jacks shall be provided for lifting entire LRVs. A bridge crane shall be provided with adequate capacity to lift the heaviest LRV component, an assembled motor truck. The bridge crane shall be so located as to allow a highway flatbed tractor/trailer to position itself under the crane and allow motor trucks and trailer trucks to be loaded for shipment.
 - Turntables and transfer tracks shall be provided for exchange and movement of trucks;
 - The daily/routine maintenance pits will be a single-level design;
 - Services in the pit areas shall include; compressed air outlets at each support column, a 120 VAC duplex receptacle at each column, welder receptacles, floor drains for pit wash down, oil drain for disposing of used gearbox oil, conduits to connect all pits for future addition of other services, radiant heating, exhaust ventilation, provisions for addition of grating, approved railings or chains, stairway access, and provisions for vertical movement of tools and components between the shop floor level and the pit level, as well as platform level. In addition to providing service at this level, the material lift shall also service the pit and maintenance floor;
 - Interlocks shall be provided to assure exclusive operation of the bridge crane or the OCS, but not both for each car position. Operation of the crane shall be allowed in a zone over the unit repair area; and
 - Platforms with an interlocking gate system shall be provided so that rooftop equipment can be serviced by maintenance personnel without requiring tie off and harness. This interlock on the gate system shall prevent cars from pulling out of the maintenance bay without the gates being secured open. Services on the platforms shall include compressed air outlets, welder receptacles, 120 VAC duplex receptacles and auxiliary power stations (APS). Each car position shall have one APS for providing auxiliary power to the LRV when the OCS is not energized. APS shall be interlocked with the OCS to assure mutually exclusive operation.

Ancillary work areas that may be included are listed below:

- Yard Operations and Central Control;
- Facility Maintenance and Storage
- Communications Equipment;

-
- Training;
 - Janitor;
 - Women's Locker Room;
 - Men's Locker Room;
 - Men's Room(s);
 - Women's Room(s);
 - Electrical Rooms(s);
 - Boiler & Mechanical;
 - Lunch Room/Ready Room;
 - Conference Rooms;
 - Administration;
 - Storage Rooms;
 - Component Repair/Rebuild Areas;
 - Shop Substation;
 - Telephone Equipment;
 - Signal Equipment Room;
 - Compressor Room;
 - Foreman's Office;
 - Inspection Pit;
 - Rooftop Level Maintenance Platforms;
 - Maintenance Areas & Offices;
 - Shipping/Receiving;
 - Fare Collection Equipment Repair;
 - Employee Exercise Room;
 - Stairs/Halls/Lobby/Elevators;
 - Body Shop;
 - Paint Shop;
 - Wheel/Axle Shop; and
 - Wheel Truing Bay.

9.5.3 Shop Functional Areas

- A small tool and parts storage room shall be provided for issuance of small specialized hand tools and frequently used consumable parts. This room shall be located in proximity to the inspection and maintenance area;
- A bridge crane with adequate capacity to lift motor trucks shall be provided in the air-conditioning current collector and brake resistor shop area. This shall be interlocked for safety with the OCS;
- A monorail crane will be provided at each car position with roof access platforms. The monorail cranes will be used to remove and replace the smaller roof top components;
- An area for secondary repair of LRV heating, ventilating and air conditioning equipment shall be provided. The HVAC component repair will be provided with coverage by the bridge crane;

-
- A parts cleaning area with suitable special ventilation and electrical service shall be provided;
 - Part of the storage area shall be designated for storage of pre-dried sand, purchased in plastic-lined bags; and
 - A fire sprinkler system shall be provided throughout the building in compliance with jurisdictional requirements. The system shall be of the dry type in areas prone to freezing and a wet system elsewhere. Chemical fire protection shall be provided for areas such as electrical rooms, and flammable storage, etc., depending on local interpretation and enforcement of code requirements. A clean agent system shall be provided for the Control Room and associated Server Room. The systems shall be held tight to the beams to avoid clearance problems with fork lifts.

9.5.4 Support Areas for Shops

The following support facilities shall be provided:

- Locker rooms, showers and rest rooms facilities for men and women;
- Employee lunch room, conference room, and training areas;
- Foreman's office, storeroom facilities, general work areas and receiving and shipping areas. Receiving and shipping areas shall be designed with docks for loading and unloading materials for the maintenance shops;
- Spare parts storage, in conjunction with the store's office and loading dock; and
- An interior inventory storage area for wheels, trucks and other large parts.

9.5.5 Maintenance, Operations and Administrative Areas

Space shall be provided for the management of the maintenance shops and operations facilities. Space must be provided for the Maintenance and Transportation Managers, unit supervisors, general clerical, and store-room supervisors.

9.5.6 Exterior Wash Facility

An interior (heated) automatic LRV wash and drying facility shall be provided. This facility will be located in the main building. The washer shall operate automatically upon the operator initiating the wash cycle. The wash facility shall accommodate coupled LRVs and will operate on the drive-through principle.

Provisions shall be made for the delivery and storage of cleaning agents at or near the washer. Facilities shall be provided to recycle wash water and special drainage and freeze protection provisions shall be included. An auxiliary equipment room shall be provided for pumps, tanks and hydraulic equipment.

The LRV wash shall provide only for exterior wash of the sides and ends of the LRV. If roof washing is necessary, a platform that allows roof access in an area where there is no overhead wire shall be provided.

9.5.7 Interior Cleaning Area

Vehicle interior cleaning will be accomplished in the covered LRV storage area. Provisions shall be made for storage of Cushman type utility vehicles for access to the LRV's, and cleaning supplies. Electric power will be necessary for powering cleaning equipment and water will be required for cleaning.

9.5.8 Electrical Supplies

A separate substation shall be provided for the shop with shop trackage electrically isolated from the yard trackage. Overhead wire in the yard and in the shop shall be sectionalized to allow the shutdown of power to individual car positions in the shop and tracks in the yard without affecting the remainder of the yard or shop. Individual lockable disconnects shall be provided for each shop car position to remove traction power when required for maintenance. The shop substation will be solidly grounded to the building ground network for safety purposes. A separate yard substation will be provided, with yard trackage electrically isolated from mainline trackage.

Electrical services other than traction power shall be provided by a separate panelboard

10.0 TRACTION ELECTRIFICATION SYSTEM

10.1 INTRODUCTION

The Traction Electrification System (TES) provides electrical power to the Light Rail Vehicles (LRV's) by the means of the traction power supply system and the traction power distribution system.

The traction power supply system consists of traction power substations located along the system route connected to the distribution circuits of the local power utility company and the DC feeder cables in underground ductbanks connecting to the overhead distribution system. The substations include all the equipment necessary to transform and rectify the utility AC three-phase voltage to DC electrification voltage.

The traction power overhead distribution system consists of simple catenary and single contact wire style overhead contact systems (OCS). At-grade mainline tracks shall use the simple catenary wiring style that consists of a messenger wire and a contact wire. In designated city streets a single contact wire with feeders is required, while at the Operations Facility, a single contact wire without feeders may be sufficient. The at-grade sections of the mainline shall be auto-tensioned by the means of balance weights, while the underground section, the yard, and the shop systems shall use fixed terminations.

The traction power supply system configuration shall be of the multiple-feed type with electrical continuity between substations. The transit vehicles will collect power from the contact wire by means of pantographs and will return the power to the substations via running rails. The mainline and yard tracks will be insulated from ground, while the shop tracks will be grounded.

10.2 FUNCTIONAL REQUIREMENTS

The traction power supply system shall maintain the distribution system voltage above the minimum allowable value. The maximum conductor temperature shall be below the limit recommended by the conductor manufacturer. The overhead contact system shall be designed to allow the trains to operate with all pantographs in contact with the conductors at up to the maximum allowable speed without excessive oscillations of the system. The design shall permit full current collection without pantograph bouncing or arcing.

All traction power and distribution system equipment shall be designed taking into account the effects of the harmonic content of the traction load, the highly fluctuating pattern of traction current, and system faults. The TES shall be designed for a minimum functional life expectancy of 30 years.

10.3 STANDARDS AND CODES

All design work and material selection shall conform to or exceed the requirements of the latest editions of standards and codes issued by the following organizations and codes:

- Association of American Railroads (AAR);
- American Railway Engineering and Maintenance of Way Association (AREMA);
- American National Standards Institute (ANSI);
- American Society for Testing & Materials (ASTM);
- Institute of Electrical & Electronics Engineers (IEEE);
- National Electrical Manufacturers Association (NEMA);
- Insulated Cable Engineers Association (ICEA);
- American Society of Mechanical Engineers (ASME);
- Underwriters Laboratories (UL);
- National Fire Protection Association (NFPA);
- National Electrical Testing Association (NETA);
- International Building Code (IBC) where applicable;
- National Electrical Code (NEC), where applicable;
- Applicable State, Local, and County Codes; and
- National Electrical Safety Code (NESC).

10.4 SYSTEM LOAD FLOW STUDY

The design of the TES shall be based on a computer-aided load flow simulation. Three car trains shall be simulated to operate for two hours on the system at headways equivalent to the existing Hiawatha schedule under normal and individual substation outage conditions with the vehicles loaded to AW2. Additional simulations will be made to model cars with a maximum current limit of 1000 amps and special case scenarios. Worst case voltages shall be identified due to simultaneous train acceleration from passenger stations. Under these operating conditions the TES design shall be shown to operate successfully within required design parameters, and voltages at trains shall not fall below 525 Vdc.

The input data shall include track gradients, track speed limits, passenger loading, passenger station locations, TPSS locations, and station dwell times, as well as the electrical and mechanical characteristics of the trains. Further, the input data shall represent the electrical characteristics of the utility electrical system, the traction power substations, the distribution system, and the power return system.

The output data shall include train operational data such as speed, distance traveled, and energy consumption for each run. For each substation, the results shall include average power, energy consumption, rectifier current, and feeder breaker current for each run. Calculations for maximum substation bus current, feeder cable size and temperature rating shall be performed. For each substation to substation section of the distribution system, the results shall include train voltage profiles and current flow in each section of the OCS. Calculations for maximum OCS conductor temperature shall be performed.

10.5 TRACTION POWER SUPPLY SYSTEM

10.5.1 System Description

The traction power supply system shall consist of all equipment between the interface points with the power utility, the distribution system, and negative return impedance bonds, direct negative return bonding or rails. The equipment includes AC cables, AC switchgear assemblies, transformer/rectifier units, DC switchgear assemblies, busbars, positive and negative cables, negative return and drainage assemblies, substation buildings, foundations, grounding systems, protective systems, auxiliary power supply systems, ventilation systems, batteries and chargers, fire detection and intrusion systems, lightning arresters, annunciation and control systems, metering equipment, and provision for supervisory control equipment.

The electrical equipment will be housed in metal prefabricated buildings constructed off site. Figure 10-1 shows a typical substation floor plan and equipment arrangement. Each substation shall be provided with heating, ventilation, lighting and AC distribution.

10.5.2 Substation Spacing and Location

Traction power substation spacing and location will be determined as the result of the Load Flow Study as well as a study resolving the needs of the system with available ROW and coordinated location design. The locations are based upon the preliminary load flow study. The substations shall be located so that the distribution system voltage does not drop below the minimum level required, the temperature of the distribution system conductors does not exceed the maximum allowable value, and the rail voltages do not exceed the maximum permissible values.

10.5.3 Substation Types

Each substation shall have one transformer-rectifier unit. Substations on the above ground sections shall have two DC feeder breakers. Substations located at the tunnel portals shall have three DC feeder breakers, substations located in the tunnel shall have four DC feeder breakers.

10.5.4 Substation Equipment Rating

The continuous rating of the substation equipment such as the traction transformer, rectifier, circuit breakers and cables shall be based on the system load flow study, but the ratings shall in no case shall be less than 1 Megawatt, 750 Vdc nominal.

Each mainline substation shall be capable of supplying the following load cycle in accordance with NEMA and ANSI standards:

- Constant temperature of all equipment shall be reached following operation at 100% rated power for a minimum of 2 hours;
- Equipment shall then be able to sustain a 150% overload for 2 hours with five evenly spaced periods of one minute each at 300% of rated load and one 15 second period at 450% of rated load, followed by a maximum short circuit current with duration equal to substation protective device clearing time. Refer to Figure 10-2; and
- Equipment shall be capable of sustaining such an overload twice a day, once in AM peak and once in the PM peak periods.

10.5.5 Substation Incoming Service

Incoming primary AC power to the Traction Power Substations shall be supplied by Xcel Energy (or equivalent) at a nominal 13.8 kV, three phase, three wire, 60 Hz. The substations shall be connected by overhead lines or underground cables to the utility three-phase distribution network. Xcel Energy (or equivalent) will provide redundant circuits to substations as required in special situations (substation spacing, tunnel sections) with this additional cost borne by the project.

The AC service and AC protection scheme will be coordinated with Xcel Energy (or equivalent).

The incoming substation service shall be by underground cables. Cable ductbanks, conduits, raceways and manholes inside the substation property line shall be designed from the point of utility interface to the traction substation. The design shall be fully coordinated with Xcel Energy (or equivalent) requirements and interfaced with the utility overhead or underground facilities. The feeder rating shall permit the substations to supply the specified load cycle and short circuits without exceeding the allowable equipment temperatures.

The incoming service will be accompanied by an exterior receptacle for an emergency power input (Generator) and manual internal transfer switch as part of the Substation equipment package to allow for emergency power during a utility power loss.

10.5.6 AC Switchgear

The AC switchgear assembly shall provide the means to deliver, control and measure the substation power requirements. The assembly shall be housed in dead-front enclosures containing AC drawout vacuum circuit breakers, relaying, metering equipment.

The equipment shall conform to ANSI C37.20.2 “IEEE Standard for Metal Clad and Station Type Cubicle Switchgear”, and shall be UL listed and labeled, or certified by a independent testing laboratory to meet ANSI and UL standards. Working space shall be provided to access components from the front or the rear of the switchgear.

10.5.6.1 Protective Devices and Relays

Based on the magnitude of load, equipment ratings, and available short circuit currents, a comprehensive coordination and protective device study scheme shall be performed for the design of the apparatus to protect the AC switchgear and downstream substation equipment.

All protective relays shall be high quality utility-type draw-out devices enclosed in rustproof, dust-proof, high-impact cases with integral test switches. The protective relays shall be self-reset and shall have seal-in, hand-reset targets indicating relay operation. The relays shall be arranged to be visible, accessible for maintenance and logically grouped, with devices of related functions located in proximity to each other.

10.5.6.2 Power Monitor

A power monitor shall be provided which shall have a digital readout which shall monitor and display amperes per phase, AC volts line to line and line to ground, and kW. The output of the monitor shall be suitable for connection to Supervisory Control and Data Acquisition (SCADA) using an appropriate interface.

10.5.7 Rectifier Transformer

The rectifier transformer shall be dry-type, self-cooled, with primary voltage to be consistent with utility supply, and equipped with appropriate taps. The transformer/rectifier shall be designed to provide the following:

- Maximum voltage at 1% load shall not exceed 800 Vdc.
- Minimum voltage at 100% load shall not fall below 705 Vdc
- Minimum voltage at 450% load shall not fall below 565Vdc.
- Regeneration voltage will be limited to 900 VDC.

10.5.8 DC Switchgear

The DC switchgear assembly consists of the positive switch, negative switch, rectifier, buswork, controls, and DC circuit breakers. It shall form a lineup of dead-front metal enclosed switchgear built to ANSI C37.20.2 “IEEE Standard for Metal Clad and Station Type Cubicle Switchgear”, except that the positive and negative switch and rectifier cubicles may alternately be constructed to ANSI C37.20.3 “IEEE Standard for Metal Enclosed Switchgear”.

10.5.8.1 Circuit Breakers

The DC circuit breakers shall be high speed, stored energy, draw-out, single-pole units and shall have bottom feeder cable entry.

10.5.8.2 Protective Devices and Relays

The DC protective devices and relays shall protect the overhead distribution system and feeder cables, as well as provide back-up for the transit vehicle protective devices.

The protection scheme shall employ protection against instantaneous overcurrent, low resistance frame fault, incomplete sequence, reverse current, and rail-to-earth potential.

A “rate of rise” relay shall be provided to protect the DC system from faults.

A “transfer trip” shall be provided to trip feeder circuit breakers adjacent to the section where a DC fault is detected. An auto-reclose circuit will sense whether the fault is cleared or remains. The circuit will command the circuit breakers reclose if the fault is removed within a preset number of tries. Otherwise, the circuit breakers shall remain open and lock themselves out.

Rail-to-earth tripping shall be by a dedicated relay, either PLC or Microprocessor based, featuring adjustable voltage level and adjustable time delay, and a 4-1/2 digit panel mounted display.

10.5.8.3 Positive Disconnect Cubicle

The positive disconnect switch shall be motor operated, single pole, bolted pressure type with a solid copper blade and silver-plated contacts, and operated by the DC control voltage. The switch shall be interlocked with the AC switchgear and DC feeder breakers to insure no-load opening. DC feeder breakers shall reclose after the positive switch is open in order to isolate the transformer-rectifier unit in the case of an internal fault while allowing continuity of the DC distribution system. The positive disconnect switch shall be key interlocked with the negative disconnect switch such that the negative switch cannot be opened unless the positive switch is opened.

10.5.8.4 Negative Cubicle

The negative cubicle shall include the negative disconnect switch, negative busbar, terminations for negative return cables, and other associated equipment. All equipment and bus insulation shall be rated at the system maximum rated voltage.

10.5.8.5 Rectifier Cubicle

The rectifier shall be silicon diode type, natural convection-cooled. The rectifier shall be a complete operative assembly consisting of the diodes, heat sinks, internal buses, connections, diode fuses, and all other necessary components and accessories. It shall consist of full-wave bridges providing 12-pulse rectification.

10.5.9 Substation Alarm Panel (SAP)

The Substation Alarm Panel shall be built to ANSI C37.21 "Standard for Control Switchboards", and shall contain the substation annunciator, transformer supervisory alarm panel, and SCADA system capable of an IP connection or a direct serial interface, as is required by the equipment capabilities.

This SCADA system will be capable of providing discrete IO if the design and equipment require this function to enable all necessary controls and indications

10.5.9.1 Annunciation

The substations shall be equipped with an internal annunciation system and provision for a remote annunciation system through SCADA. The annunciation shall be of modular design, convection-cooled, solid-state and programmable. The annunciator shall consist of LED indicating lamps, audible alarm, test, silence, acknowledge and reset switches, as well as other associated equipment.

An electrical alarm "points list" shall be developed which indicates electrical alarms to be annunciated. These alarms are shown on the substation single line drawings and consist in part of breaker trip, transformer over-temperature, rectifier over-temperature, and other alarms. These alarms will be annunciated locally, and an annunciator relay contact shall provide interface with the SCADA system.

In addition to the electrical alarm functions described above, an intrusion alarm will be generated upon unauthorized entry, and fire and smoke alarms generated in the event of detection. Fire and intrusion alarms will be sent to Central Control via SCADA.

10.5.9.2 SCADA Provisions

Each substation shall be equipped with a SCADA system capable of accepting serial data, IP data or discrete inputs as needed to interconnect the SCADA system with each alarm condition shown on the annunciation panel.

A SCADA points list will be developed with Metro Transit staff that includes alarms, status and supervisory control functions. Alarms will consist of all locally annunciated alarm points discussed in 10.5.9.1. Status points will consist of breaker position, and other necessary points selected to give information about the condition of the remote station to central control. Supervisory Control Lock-out (local) shall be provided.

Equipment must be specified to accommodate SCADA functions desired. Supervisory control of the DC feeder breakers shall be provided. The supervisory control will permit remote opening from Central Control. All electrically operated circuit breakers will be specified to accommodate SCADA control.

10.5.10 Substation Low Voltage Auxiliary Power

The voltage requirement for auxiliary equipment varies with location: 120/240V, 1-phase or 208Y/120V, 3-phase, as appropriate.

Low voltage auxiliary AC components shall include the auxiliary power transformer and AC panelboards (Panel P1 and PD1) for the traction power battery charger, and substation auxiliary AC equipment including, lighting, convenience receptacles, and HVAC. Panel P1 will be a main breaker branch circuit panelboard dedicated to feeding substation loads exclusively. Panel PD1 will be a distribution panel adequately sized to power non-substation “hotel” loads. PD1 shall feed other panelboards or large feeder loads, and not feed branch circuits, either inside or outside of the substation (example: sprinkler controllers or traffic signals).

Substation AC auxiliary power shall be used for large “hotel” loads, which may include signal systems, communications systems, station platforms, transit facilities, parking lot lighting, or other branch circuit panelboards which feed external loads, where appropriate.

Each substation shall be furnished a DC control voltage distribution panelboard. The DC panelboard shall supply all substation control power loads at 125 VDC.

10.5.11 Busbars and Bus Connectors

This section applies to all TES equipment including connecting buses between switchgear and transformers, AC switchgear, and DC switchgear including rectifier.

The busbars and bus connections shall be designed to withstand, without damage to the bus or enclosure, the thermal and mechanical stresses occurring during the specified load cycle and the rated short circuit currents.

Busbars shall be made of rigid high electrical conductivity copper and shall be adequately insulated and braced with high strength insulators. Bus connections shall be bolted and furnished with silver-plated surfaces. Each joint shall have conductivity at least equal to that of the busbar.

Bus bars for Metal Clad switchgear shall be insulated per ANSI C37.20.2.

10.5.12 Equipment Arrangement

Substations shall have adequate area to accommodate all the electrical equipment and ancillary components. Relative spacing and positioning of each item of equipment shall permit maintenance, removal and replacement of any unit without the necessity of moving other units. The arrangements of the equipment shall permit doors to be opened, panels to be removed, and switchgear to be withdrawn without interference to other units. Ceiling heights and structural openings shall permit entry and removal of the largest components installed in the housing.

Wall space for future growth will be provided. Working clearances will be provided that meet or exceed NEC requirements. A minimum of 6 ft of space in front of high voltage AC and 750 Vdc DC switchgear shall be provided. Two exit doors with panic hardware, one from each end of the switchgear, shall be provided.

10.5.13 Grounding

Each traction power substation shall be provided with a ground mat. The ground mat shall be constructed of bare copper or "Copperweld" conductors and ground rods exothermically welded together.

Grounding connections shall carry the rated short circuit current.

Ground mat conductors shall be totally encased in native soil. A layer of coarse, clean, crushed gravel, free of fines, shall be placed over the soil. A layer of filter fabric shall be placed between the soil and gravel to prevent contamination of the gravel from the soil. A surface layer over the gravel may be asphalt, masonry, or concrete.

The ground mat shall be designed to protect personnel from step and touch potentials which may arise under substation fault conditions, and to meet the requirements of the IEEE Standard 80. The mat shall be used to solidly ground traction power transformer enclosures, auxiliary power transformer neutrals, building and doorframes, ac switchgear enclosure and low voltage

panels. The ground mat shall extend 5 feet beyond equipment enclosures and/or metallic fences if provided.

10.5.14 DC Underground Distribution Feeders

The underground distribution feeder cables shall be insulated to 2 kV and sized according to the calculations conducted during the System Load Flow Study.

10.5.15 Traction Power Substation Packaged Buildings

10.5.15.1 Minimum Inside Dimensions

- Length 38.0 ft.;
- Width 15.0 ft.; and
- Height 9.5 ft.

The 9.5 ft height shall be clear, unobstructed from floor to ceiling, and dedicated for conduit, cable trays and interconnecting wiring only. Ductwork, structural members, lighting or any other equipment or appurtenances are not permitted in this dedicated space.

One 3 ft wide man door, and the double doors, shall have a clear height of 8.5 ft to allow one section of switchgear to clear the opening and permit installation or removal of equipment.

Full height double doors shall be provided for access and maintenance of the medium voltage AC switchgear from the rear. The doors shall be hinged, gasketed, rain tight, latched and pad lockable from the outside. Hardware shall be stainless steel.

10.5.15.2 NEC Working Clearances

Working Clearances will be according to the National Electrical Code for all conditions encountered to provide adequate working spaces according to the code without excessive wasted spaces.

10.5.15.3 Insulation and Moisture Barrier

Provide insulation sufficient to prevent condensation, especially from the roof. Insulation may be fiberglass batt in the walls and solid insulation on the roof.

Provide a permanent moisture barrier under the concrete to prevent the wicking of moisture from soil beneath the concrete slab.

10.5.15.4 Framing Channel

Framing channel, Unistrut or equal, shall be provided every 4 ft on ceiling for the support of lighting and equipment to be installed in the TES Contract.

10.5.15.5 Insulated Floor

The substation building floor shall be coated with a dielectric epoxy material to insulate and electrically isolate the DC switchgear from any grounded objects. The coating shall be applied to the floor, and the inside of the trench. The surface of the floor shall be non-slip.

10.5.15.6 Heating, Ventilation, Air Conditioning (HVAC)

Staged ventilation shall be provided. Heating shall be provided by an electric unit heater, forced air, and thermostat, ceiling or wall mounted.

The substations may be either air-conditioned or ventilated, provided the following minimum criteria are met:

- Maximum Design Outside Air Temperature 92°F;
- Minimum Design Outside Air Temperature -12°F;
- Substation Equipment Heat Load 35kW;
- Minimum permissible inside temperature (Eqpt Off) 40°F; and
- Maximum permissible inside temperature 104°F.

During extremely hot weather, the substation temperature may rise above 104°F, and this shall be addressed by the HVAC designer. The following calculations shall be provided to verify the HVAC design:

- Calculated fan HP and CFM; and
- Calculated maximum substation inside air temperature given outside ambient temperatures of: 95°F, 100°F, and 105°F.

Ventilation thermostats shall be two-stage and set so that the first stage turns on at 85°F, and off at 80°F. The second stage of ventilation will turn on at 95°F. The heating should turn on at 40°F and off at 45°F unless manually overridden.

Thermostats should be continuously adjustable "manual-on-off" to allow for maintaining comfortable temperatures when maintenance personnel are working within the substation.

Filters and louvers will be provided to filter outside air. Filters shall be of the disposable type, and sized to be replaced no more than once per month.

Two adjustable air dampers shall be provided within ductwork to adjust the flow of air over the transformers and heat generating electrical equipment. Duct openings shall be positioned for maximum cooling of the transformer and rectifier. All ventilation ductwork and fans shall be located above the dedicated 9.5 ft ceiling space.

10.5.15.7 Electrical Lighting and Receptacles

Substation lighting will be 4-lamp, open industrial fluorescent luminaires using F40T12 lamps with 41K color temperature. Other configurations that meet the lighting levels and other criteria may be accepted upon engineers review. Lighting shall be surface mounted directly to the Unistrut framing provided with the building. Lighting levels shall be designed for 35 to 50 foot-candles, average.

Emergency lighting shall be by wall-mounted emergency lighting units with integral battery suitable for 90 minutes minimum operation at rated lamp output. Emergency lighting will be for egress only, and not sized for illumination sufficient for maintenance of equipment. Emergency lighting shall turn on upon loss of power, regardless of whether the substation is manned. This is to provide for illumination in the event of an accident within the substation that trips the auxiliary power.

Exterior lighting will be controlled by a photocell control switch. Exterior lighting will be on its own circuit, and wired back to the AC panelboard.

Lighting and receptacles shall be furnished and installed with the substation building. Receptacles will be installed flush, located near the doors. Interior lighting, and interior convenience receptacles will have a separate circuit wired back to the AC panelboard P1.

Branch circuits that feed loads not related to the substation loads, such as sprinkler controllers, are not permitted within the substation.

10.5.15.8 Conduits, Cable Tray, and Trench

All wire and cable shall be installed in conduit or cable tray. Large power cables, or multi conductor control cables shall be in cable tray. Wireways are not permitted.

Type EMT or GRS conduits may be used in dry locations, inside the substation only, and may be exposed or concealed in the walls.

PVC/GRS conduit or epoxy-coated GRS may be run in earth, or embedded in concrete.

PVC conduit shall not be used except when concrete encased.

A dedicated 18 in. by 18 in. concrete trench or cable tray shall be provided under the substation building floor, in the foundation crawl space area to allow for installation of both DC and high-voltage AC conductors. The AC and DC portions shall be separated by a partition. Trench covers shall be provided over trench spaces dedicated for future sections of switchgear.

10.5.15.9 Utility Monitoring Enclosure, TES Emergency Shutdown and Metering

Each substation shall be equipped with traction electrification emergency shutdown buttons. One button shall be flush mounted in a NEMA 4X stainless steel enclosure mounted in an exterior wall, and accessible by key only. The other enclosure shall be located inside by a door. Actuation of the button will trip and lock out the 13.8 kV AC and DC breakers of the substation, and transfer trip and lock out the DC breakers at the adjacent substation for the line sections, thus completely isolating the sections.

Each substation shall be equipped with a utility monitoring enclosure, which is provided to the utilities for the purpose of monitoring stray currents. The enclosure shall be a NEMA 3R stainless steel enclosure. A removable stainless back panel will be provided for the mounting of terminal blocks and a 120 volt duplex receptacle installed for chart recorder power from Panel P1. Conduits shall be provided for the power for the 120 volt duplex receptacle, and a conduit provided for ground conductors run from the negative cubicle, and connection to the negative shunt.

A meter socket shall be semi-flush mounted in substation outside wall, and be in accordance with Xcel Energy requirements. The center of the socket shall be at 72 in. above grade. A 1.5 in. conduit shall be run to the metering compartment of the 13.8 kV switchgear. The meter, CT's, PT's and metering conductors will be provided by Xcel Energy at the time of service.

10.6 OVERHEAD CONTACT SYSTEM

10.6.1 System Description

The traction power overhead contact system (OCS) consists of all equipment between the interface with the DC traction power supply equipment and the vehicle pantograph. The equipment shall include foundations, poles, cantilevers, bridge arms, system conductors, feeders, hangers, jumpers, terminations, tensioning devices, sectioning equipment, disconnect switches and all other necessary equipment.

The OCS shall be designed visually unobtrusive. Within the mechanical and structural design constraints, the system structures and associated equipment shall be lightweight and shall use visually unobtrusive fittings. The messenger and contact wires shall be double-insulated with each level of insulation compatible with the system insulation class.

Clearances for overhead conductors can be found on Figures 10-5 and 10-6.

10.6.2 Operating Condition and Non-Operating Condition

The design of the overhead contact system shall include consideration of the effects of the following combinations of climatic conditions:

- Operating Condition is defined as either 1. the presence of no ice with a 55 miles per hour wind, or 2. the presence of a maximum of a 40 miles per hour wind with $\frac{1}{4}$ inch of radial ice on contact wire and $\frac{1}{2}$ inch of radial ice on messenger wire: whichever is more onerous.
- Non-Operating Condition is defined either 1. the presence of a 90 miles per hour wind without the presence of ice, or 2. the presence of $\frac{1}{2}$ inch of radial ice on contact wire and $\frac{1}{2}$ inch of radial ice on messenger wire.

Operating Condition is to be included in engineering analysis relating to the normal operation of trains. Non-Operating Condition is to be included in engineering analysis of the structural adequacy of the designed Overhead Contact System.

10.6.3 Distribution System Design Study

The design of the OCS for the mainline shall be based on an engineering study. The study shall include calculations of the distribution system design parameters and shall take into account all factors that contribute to displacement of the contact wire with respect to the pantograph, including:

- Climatic condition;
- Conductor data;
- Pantograph security;
- Conductor stagger;
- Pole deflection due to loads imposed;
- Erection tolerances;
- Vehicle roll and lateral displacement;
- Sway of pantograph; and
- Track maintenance tolerances.

The result of this study shall include:

- Maximum structure spacing as a function of track curvature;
- Conductor blow-off, stagger effect and allowable static offset;
- Conductor rise and fall over the range of climatic conditions;
- Conductor along-track movement, stagger variation and wire elongation;

-
- Conductor tensions, sags and factors of safety under various climatic conditions;
 - Contact wire stagger variation due to movement of hinged cantilevers;
 - Conductor profile, hanger lengths and spacing;
 - Equipment vertical, wind and radial loads

10.6.4 Sectioning

The system sectioning shall be designed to enable the electrical protective devices to isolate faulted sections of the distribution system, perform planned maintenance, and achieve flexible operation during system emergencies.

Sectioning at substations and elsewhere shall be performed by means of insulated overlaps where possible. Where overlaps cannot be used for sectioning of mainlines and revenue service crossovers, high speed bridging section insulators shall be used.

The primary connection and isolation of the system sections shall be performed by the substation DC feeder circuit breakers. At locations along the route, connections and isolation of the system sections shall be accomplished by disconnect switches.

10.6.5 System Types

Four distinct types or styles of OCS shall be used: a) auto-tensioned simple catenary system, b) auto-tensioned single contact wire system, c) fixed termination single contact wire system, and d) fixed termination simple catenary system.

A simple catenary system shall consist of a messenger wire supporting a contact wire by the means of hangers.

Auto-tensioning shall be accomplished by means of balanceweights, which shall be mounted on anchor poles located at the ends of each tension length. As the conductors contract and expand with temperature variation and long term creep, the balanceweights will rise and fall and thus maintain a constant conductor tension throughout the specified temperature range. Suitable anchor arrangements shall be used in the center of each tension length to prevent along-track movement of the OCS at that point.

An auto-tensioned single contact wire system shall be used in streets where the environmental impact of simple catenary construction is not acceptable.

A fixed termination contact wire system shall be used in the yard and shop. In a fixed terminated system the conductor tension will vary with temperature variation due to the fixed conductor terminations.

A fixed termination simple catenary system shall be used in sections of the tunnel.

In street, the single contact wire system shall be supplemented by along-track paralleling feeders. The feeders shall be insulated cables installed in raceways and shall be connected to the contact wire at approximately equal intervals.

Simple catenary shall be supported and registered by means of hinged cantilevers attached to steel poles located between the tracks wherever possible. At special locations, such as track crossovers and turnouts, the OCS may be supported by cantilevers mounted on poles located on the outer sides of the track or attached to cross-span wire arrangements. The contact and messenger wires shall be staggered at registration points to achieve even wear of pantograph carbon collectors.

The system in the streets shall be supported and registered by means of cantilevers and cross-span wires. The contact wire shall be staggered at registration points.

10.6.6 Structure Spacing

Structure spacing for the OCS shall be as long as possible and shall be based on the distribution system design study results. The structure spacing shall be optimized so that the contact wire will remain within the pantograph collector head and achieve the specified pantograph security.

10.6.7 Tension Length Design

The OCS shall consist of a number of tension length sections. Each tension length shall be designed as long as possible considering the mechanical constraints of the system design, such as displacement of contact wire due to swinging cantilevers, tension loss along the system, balanceweight travel and manufacturing limits of conductor length. Further, the tension length design shall take into account the sectioning requirements.

Tension lengths shall be terminated at each end by auto-tensioning devices or fixed terminations, as applicable. Half tension lengths, where one end of the length utilizes a fixed termination and the other end a balanceweight, shall be permissible where sections are not divisible into complete tension lengths or on steeply graded sections of track exceeding 4%. For location where one end of the half tension length is at a higher elevation than the other end the fixed termination shall be placed at the higher elevation where possible.

10.6.8 Overlaps, Crossovers and Turnouts

Overlaps shall be used between adjacent tension lengths to provide mechanical continuity of the overhead system and to permit passage of the vehicle pantograph from one tension length to another. Crossover and turnout

arrangements shall be used at track special work locations where trains change tracks and where they leave or enter the mainline.

The overlap, crossover and turnout arrangements shall be designed considering the electrical and mechanical properties of the overhead system. The designs shall enable a uniform uplift of the contact wires of each system with no hard spots. A smooth pantograph passage and good current collection without arcing shall be achieved under all operating conditions.

Sufficient electrical and mechanical clearances shall be maintained between adjacent cantilevers and between the cantilever frames and adjacent conductors. This shall be particularly important for the auto-tensioned system where the cantilevers of adjacent tension lengths move in opposite directions as the temperature changes and can cause misalignment of the system.

The overlap, crossover and turnout arrangements shall be designed using single poles with twin cantilevers. Only where this arrangement is not possible, two poles with one cantilever each may be used. In areas where center poles are used, the overlaps shall be staggered along the track to reduce pole loading.

10.6.9 Foundations

The design of foundations for supporting structures and guy anchors shall be based on the structure loading calculations and soil data. The supporting structure foundations shall be designed to accept bolted base poles and shall have provision for feeder conduits and structure grounding.

10.6.10 Poles and Supporting Hardware

All poles shall be designed as free standing except for termination poles. All poles shall have a base plate drilled to fit the foundation bolt pattern and shall have provision for grounding or bonding conductors.

Base plate and foundation bolt dimensions shall be dimensioned such the poles of a given strength class cannot be installed on a foundation with inferior capacity. Preference shall be given to pole designs that are interchangeable with functionally similar pole types already existing in the light rail system.

For open track the poles shall be 8 in. to 14 in. wide flange beams mounted between the tracks except where special conditions require side poles. For operations in paved track where aesthetics are important, tapered tubular steel poles, side-mounted, ranging from 9 in. to 17 in. in diameter depending on the application will be used.

Structures shall be designed so that the normal operating across-track live load deflection of any structure shall not exceed 2 in., i.e., 1 in. in either direction laterally, at contact wire height.

10.6.11 Cantilevers

The cantilevers shall be designed for a range of loads, pole to center-of-track distances, and for a range of system heights considering the system installation tolerances. The cantilever members shall be designed for easy installation and field adjustment.

10.6.12 Bridge Supports

Bridge supports shall be used where sufficient clearance to accommodate a cantilever-type assembly is not available. The supports shall be designed to restrict the uplift of the contact wire when subjected to pantograph pressure and shall be capable of providing vertical and across-track adjustment. The restrictive feature shall be field adjustable. The bridge supports shall permit the longitudinal movement of contact wire, and messenger wire where appropriate.

10.6.13 Insulators

Insulators shall be specified to provide electrical insulation in accordance with the system insulation class and shall have the mechanical safety factors specified.

The insulators shall have resistance against deterioration from exposure to sunlight and airborne chemical pollution. The life expectancy shall be compatible with that of the rest of the equipment.

10.6.14 Conductors and Associated Items

Contact wire shall be solid, grooved, hard-drawn copper conductor. The messenger wire shall be stranded, hard-drawn copper conductor. All feeder, connecting, and jumper cables shall be insulated, stranded copper conductors with sufficient flexibility to prevent fatigue failure of the cable due to vibration of the overhead conductors.

All conductor connections, attachments, hangers and clamps shall be copper or bronze fittings and shall be designed for ease of replacement and maintenance.

Continuity and equalizing jumpers shall be flexible stranded copper conductors. The spacing of the jumpers shall be determined based on the required current conductivity. However, a minimum of one equalizing jumper per span shall be used.

10.6.15 Terminations and Midpoint Anchors

Strain-type termination assemblies shall be of light weight and aesthetically pleasing appearance. Wire wrap, straight line, cone, or wedge type designs are acceptable. Turnbuckles shall be included as appropriate and shall have adequate adjustable length.

A mid-point anchor arrangement shall be used at or near the mid-point of each tension length of auto-tensioned equipment to restrict movement of the conductors at that point.

10.6.16 Tensioning Devices

The auto-tensioned system conductors shall be tensioned using cast iron or steel balanceweights. At wide flange beam poles, the balanceweights shall be positioned in the pole web to be as unobtrusive as possible. In areas frequented by passengers or pedestrians, the balanceweights shall be provided with a protective shield. At tubular poles, the balanceweights shall be inside the poles. The tensioning devices shall accommodate conductor expansion and contraction and shall be provided with broken wire arrangements. All operating cables shall be of flexible stainless steel wire.

Spring or hydraulic tensioning devices may be used for short tension lengths such as at crossovers.

10.6.17 Sectioning Equipment

No load break disconnect switches shall be used to electrically connect and disconnect line sections. The disconnect switches shall be rated to withstand the system worst-case overload and short circuit conditions without overheating. The switches shall be capable of breaking the maximum load current under emergency conditions. The switches shall also be configured to allow remote sensing to the Rail Control Center (RCC).

10.6.18 Other Materials

Over-voltage protection for the overhead system shall be provided by surge arresters. The arresters shall be rated to withstand the maximum system voltage and anticipated voltages induced from any paralleling high-voltage transmission lines onto the system conductors. The surge arresters shall be capable of equalizing and/or discharging the energy resulting from lightning strikes to the system.

At a minimum, surge arresters shall be located adjacent to each substation feed point, between feed points, and in all areas of reduced clearances, such as at overhead bridges and at tunnel portals.

10.6.19 Protective Screening

When the LRT is constructed below bridge, building, and structure, screening and fencing shall be erected on the structures and adjacent stairs to isolate the OCS wires from human contact where appropriate. The design of the overpass screening and/or fencing shall be compatible with the local architecture and landscape.

10.7 DESIGN PARAMETERS

- a) System Voltages
 - Substation DC 1% Full Load Voltage: 795 Vdc
 - Maximum Re-generation Voltage: 900 Vdc
 - Substation Voltage at Rated Power: 750 Vdc
 - Regulation: 6%

- b) Distribution System DC Voltages:
 - Normal Minimum: 600 Vdc
 - Emergency Minimum: 525 Vdc

- c) Distribution and Return System
 - Contact Wire Wear for Electrical Load Flow Study: 30%
 - Running Rail Weight: 115 lbs per yard

- d) Maximum Rail-to-Ground Voltages
 - Normal Operation: 50 V
 - Emergency Operation: 90 V

- e) Climatic Conditions
 - Maximum Ambient Temperature: 120°F
 - Minimum Ambient Temperature: -40°F
 - Radial Ice Loading: 0.5 in.
 - Maximum Wind Speed: 90 mph

- f) Auto Tensioning Limits
 - Lower Limit Temperature: -20°F
 - Upper Limit Temperature: 120°F

- g) Conductor Sizes and Material
 - Messenger Wire: 500 kcmil
19 strand
 - Contact Wire: 350 kcmil HD
Copper
 - In Span Jumper Wire: 250 kcmil
 - Insulated Underground parallel feeder (downtown): 500 kcmil

-
- h) Factors of Safety -- Conductors and Wires
 - Operating: 2.0
 - Non-operating: 1.6
 - Contact Wire Wear for Mechanical Design: 30%

 - i) Factors of Safety -- Hardware
 - Strain Insulators – Operating Condition: 4.0
 - Operating: 2.5
 - Non-operating: 2.0

 - j) Minimum Electrical Clearances
 - Static Clearance: 4 in.
 - Passing Clearance: 3 in.

 - k) Minimum Contact Wire Height Above Top-of-Rail
 - Exclusive Right-of Way, At-Grade: 13'-10"
 - In-Street System: 18'-6"
 - Road and Street Grade Crossings: 18'-0"
 - Tunnel: 13'-10"

 - l) Contact Wire Gradients
 - Wire gradient shall be designed for a slope of 1 in 300 unless other criteria prevail.
 - The following shall be considered as maximum gradients for design.
 - Column A shows constant gradients; Column B is for change of gradient.

Maximum Gradients for Design		
	A	B
Where possible, all speeds, Max gradients:	1 in 300	1 in 600
up to 30 mph	1 in 150	1 in 300
up to 35 mph	1 in 165	1 in 330
up to 40 mph	1 in 195	1 in 390
up to 45 mph	1 in 225	1 in 450
up to 50 mph	1 in 240	1 in 480
up to 55 mph	1 in 270	1 in 540

- m) Pantograph Security
 - Minimum Pantograph Security: 3 in

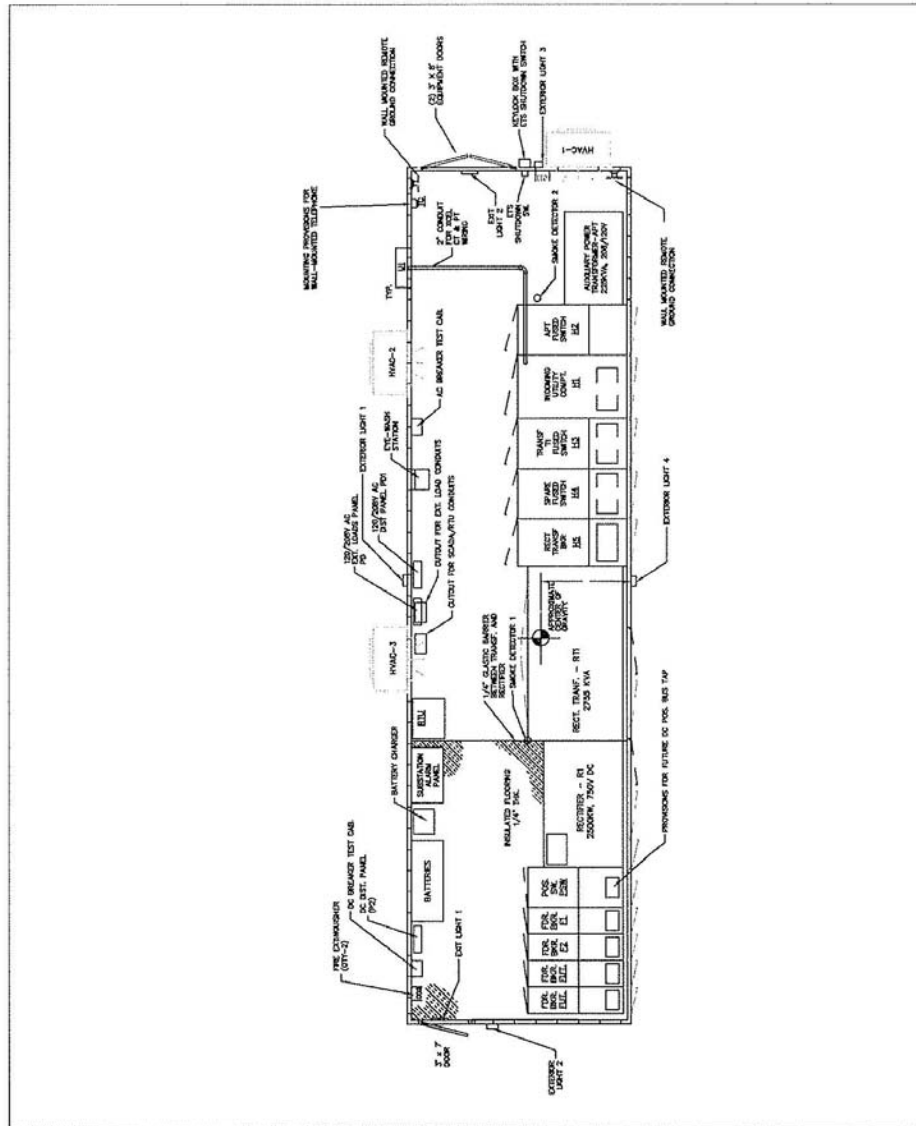

Central Corridor Light Rail Transit

Figure 10-1

Design Criteria

**TYPICAL SUBSTATION
PLAN LAYOUT**

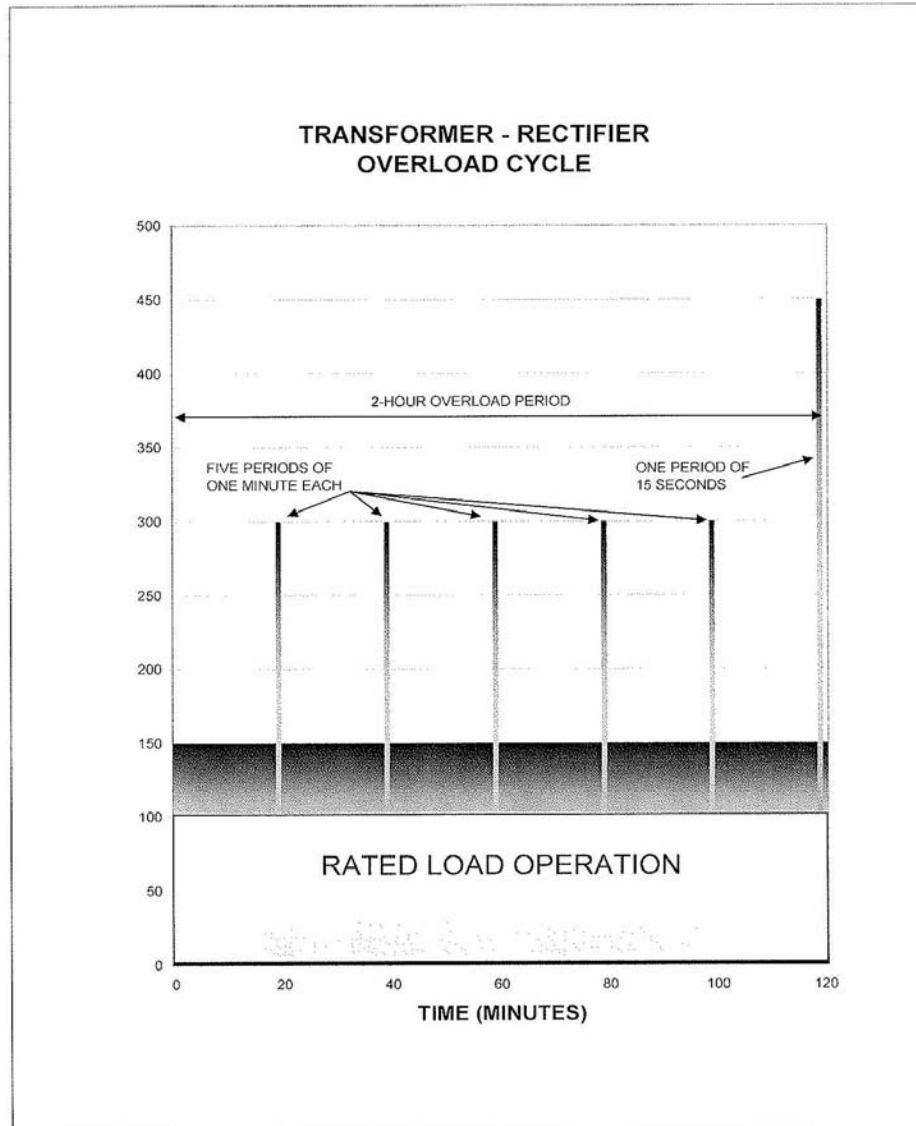

Central Corridor Light Rail Transit

Figure 10-2

Design Criteria

**TRANSFORMER – RECTIFIER
OVERLOAD CYCLE**

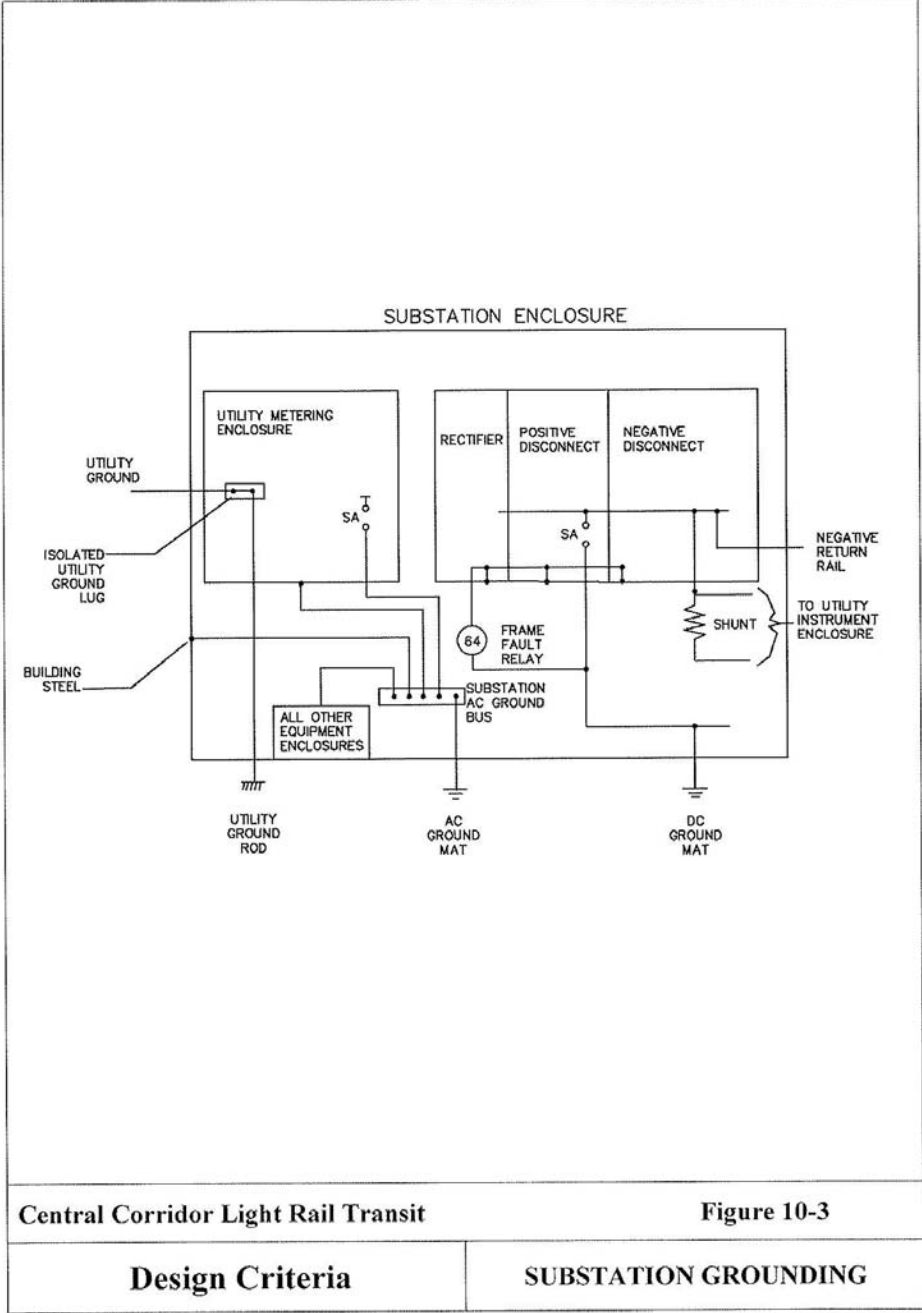

Central Corridor Light Rail Transit

Figure 10-3

Design Criteria

SUBSTATION GROUNDING

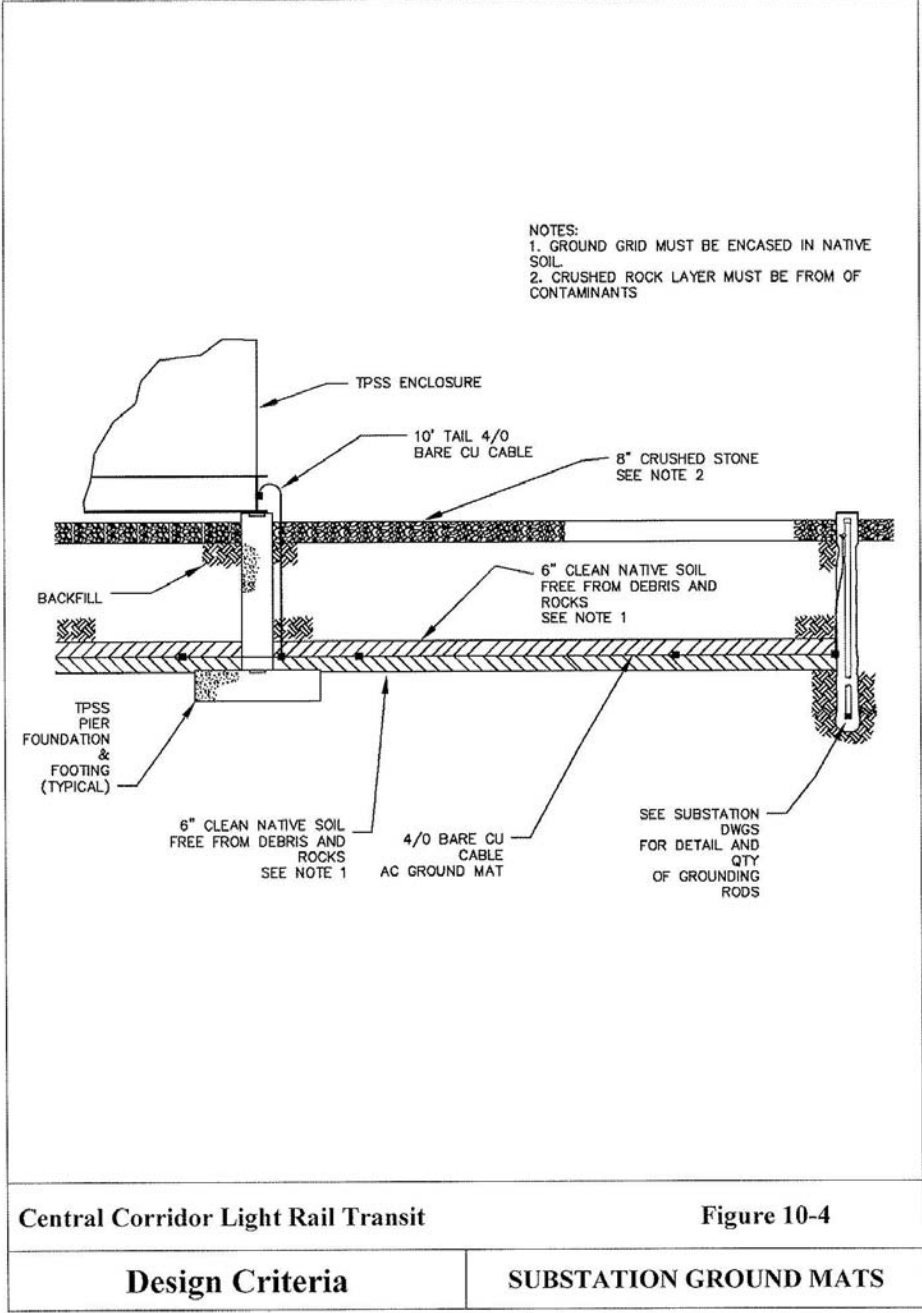

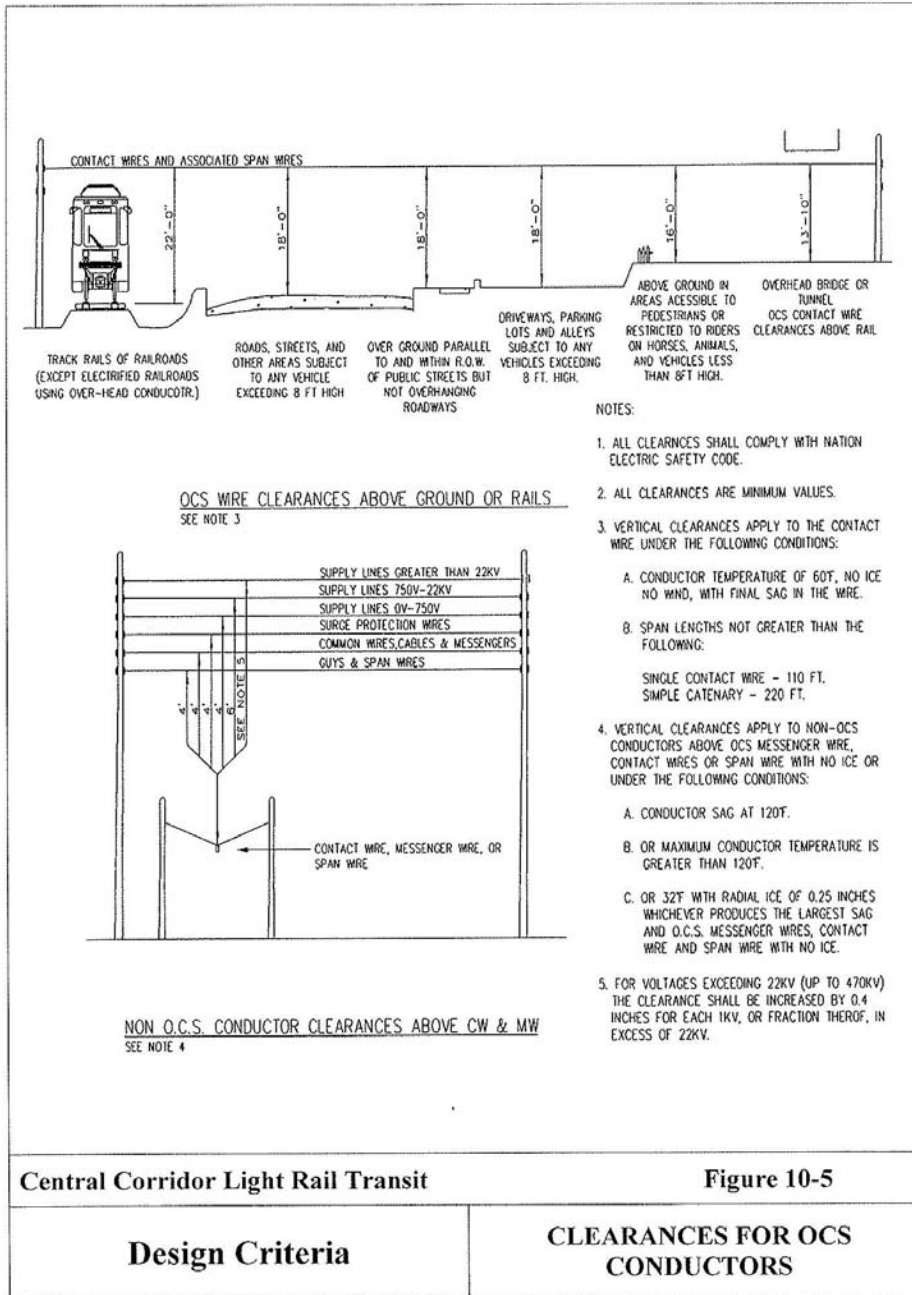

Central Corridor Light Rail Transit

Figure 10-5

Design Criteria

CLEARANCES FOR OCS CONDUCTORS

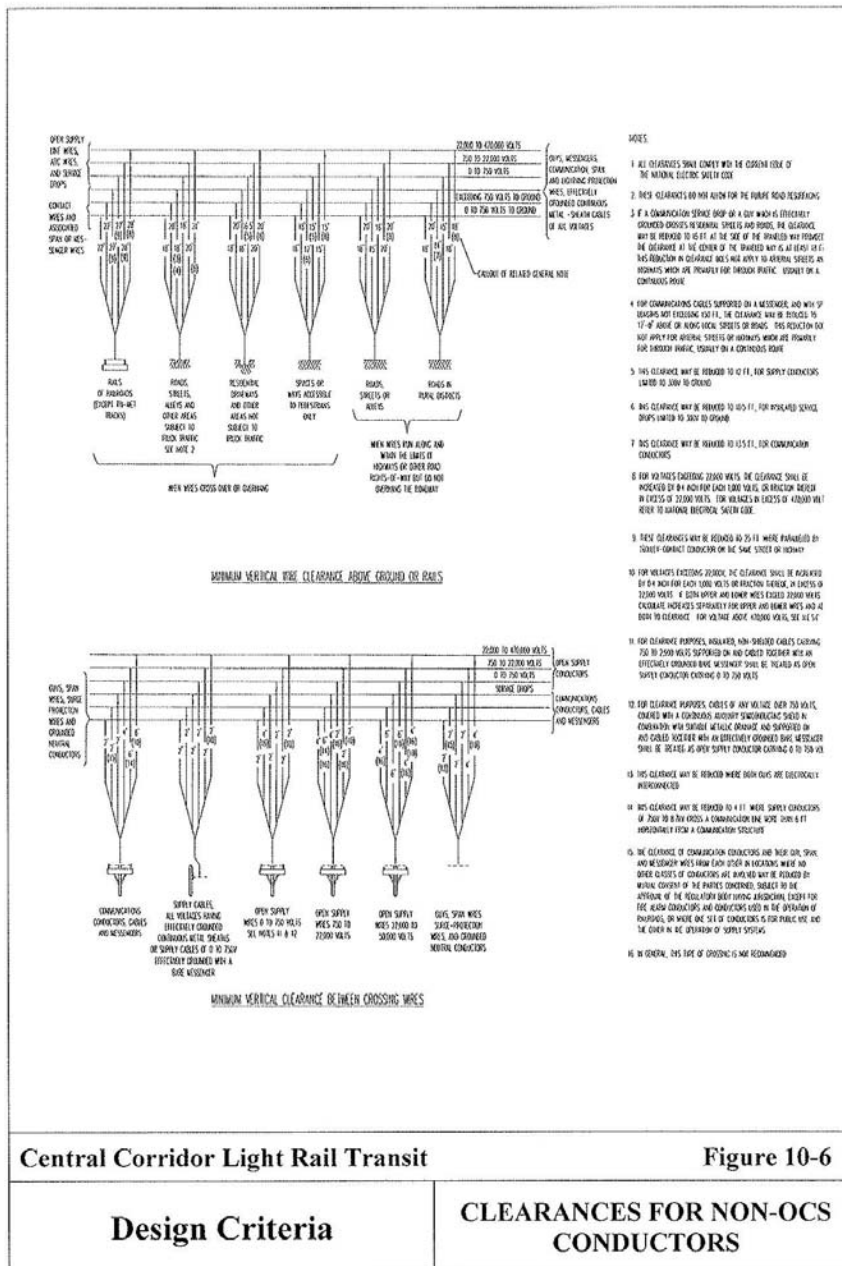

Central Corridor Light Rail Transit

Figure 10-6

Design Criteria

CLEARANCES FOR NON-OCS CONDUCTORS

11.0 ELECTRICAL SYSTEMS

11.1 INTRODUCTION

This section establishes the design criteria for various electrical facilities including passenger stations, park and ride stations, traction power and signals/communications built-in-place buildings, operations and maintenance facilities, where applicable, and concrete encased ductbanks. These criteria include requirements for the function and design of AC electrical systems only. Refer to Section 10 - Traction Electrification System for electrical requirements specific to the DC traction power supply and distribution system. The electrical and mechanical equipment requiring power includes the following:

- Lighting;
- Heating, Ventilation and Air Conditioning (HVAC) Equipment;
- Fare Collection Equipment;
- Communications and Video Surveillance;
- Emergency Lighting and Power Systems; and
- Transit Signal Equipment.

11.1.1 Standards and Codes

- Design requirements for AC electrical systems shall comply with the current Minnesota State Building Code and all laws, ordinances, rules, regulations and lawful orders of any public entity bearing on the performance of the work. Lighting, equipment and products installed for the project which will be maintained by an agency or jurisdiction other than Metro Transit shall meet that agency's design and equipment standards.
- Standard detail plates and specifications from local jurisdictions having authority over portions of the work shall be incorporated into the design of that work.
- As of December, 2007, listed below are the principal applicable fire life safety codes and standards:
 - 2007 Minnesota State Building Code including in part:
 - Chapter 1307- Elevators and Related Devices
 - Chapter 1341- Minnesota Accessibility Code
 - Chapter 4715- Minnesota Plumbing Code

And, the following codes adopted within the Minnesota State Building Code:

- 2000 International Mechanical and Fuel Gas Codes;
- 2005 National Electrical Code;

Metro Transit has adopted a fire and life safety code “Light Rail Transit, Fire Life Safety Code, that is incorporated into these criteria as Section 2 and has requirements pertaining to this Section.

11.1.2 Products

Equipment used shall in all cases be listed and labeled by Underwriters Laboratories or another nationally recognized electrical testing laboratory acceptable to the inspection authority.

11.2 ELECTRICAL REQUIREMENTS

These criteria establish the basic design requirements for low voltage AC power systems in the following facilities, if provided:

- Passenger Stations;
- Concession Buildings;
- Traction Power and Signal/Communications Buildings;
- Operations and Maintenance Facilities; and
- Other Ancillary Facilities.

11.2.1 System Voltages

- Service Voltage

All facilities shall have as a minimum, either a 120/240V, single-phase or 120/208V, three-phase electrical service.

Facilities operating multiple three phase motor loads in excess of 5HP each, or with resistive loads drawing high current capacities, shall be designed so that the main electrical service distribution shall be 277/480V, three phase. 120/208V, three phase and/or 120/240V single phase dry-type step down transformers shall be provided to service smaller rated single phase and three phase loads. Step down transformers shall be sized to maximize the total secondary loads within the local area taking into account for voltage drop considerations. Shop areas may require minimum 75 kVA transformers to account for loads associated with special equipment.

- Utilization Voltages

Lighting:

Fluorescent	120V., 1 Phase
	277V., 1 Phase

High Intensity Discharge	120V., 1 Phase
	277V., 1 Phase
	480V., 1 Phase

Mechanical Equipment & Motors	
Motors, 1HP and above	240V., 1 Phase 208V., 3 Phase 480V., 3 Phase
Motors, less than 1HP	120V., 1 Phase
Controls	120V., 1 Phase
Fare Collection Equipment	208V., 1 Phase
Communication and Video Equipment	120 V 1 Phase
Other loads	Equipment nameplate voltage

Where single phase power is taken from a 3-phase source, the loads shall be balanced among the three distribution phases.

11.2.2 System Capacity

Power shall normally be supplied from a single power distribution panel mounted in the building or on the Station platform. The power distribution panel shall be of sufficient capacity to power all loads.

- Demand Factors

In calculating system capacity, follow the NEC when calculating the Demand Factor for facility loads by design. Lighting (normal), Lighting (emergency), Heating (optional), Ventilation (optional), Air Conditioning (optional), Fare Collection Equipment, Communications and CCTV, and all other loads identified with various duty cycle and code requirements.

Maximum load for convenience receptacles on a circuit shall be 80% of circuit capacity based on a demand load of 180 VA per outlet.

- Transformer Sizing

Transformer size selection shall be based upon the connected load and demand factors listed above with the transformer independently powering the entire system electrical load. The transformer shall provide rated kVA plus a 20% allowance for load growth with no more than 115°C rise above 40°C ambient.

11.2.3 Power Distribution Method

The distribution system shall be designed so that failure of any one feeder or branch overcurrent device, conductor, or raceway will not result in total disruption of electrical services required for normal and safe operation of the facility. All branch circuit and main overcurrent protective devices for

external loads served from a Traction Power Substation shall be located outside of the Substation building.

- Load Distribution

Loads shall be locally fed from power distribution panels. Each major distribution element shall be fed from a separate feeder circuit breaker, feeder taps shall not be permitted.

11.2.4 Equipment

- General

Distribution equipment shall be based upon electrical load flow analysis. Sizing of equipment shall include:

- Overcurrent protection size requirements (circuit breakers and fuses);
- Wire, cable and raceway sizing;
- Surge protection for service entrance equipment, and distribution panelboards (if required); and
- Transformer capacities.

- Low Voltage Distribution Switchboards and/or Panelboards

- Low voltage distribution switchboards shall have a main circuit breaker and distribution circuit breakers for each feeder circuit;
- Low voltage panelboards shall have a main circuit breaker and distribution branch circuit breakers for each branch circuit;
- Circuit breakers for feeders shall have provisions for pad-locking in the OPEN position; and
- Circuit breakers shall electrically and mechanically trip free.

- Instrumentation and Metering

- Electrical service metering shall conform to the requirements of the utility company, Xcel Energy.

- Overload Coordination

- Phase overcurrent and ground fault devices shall be coordinated such that ground faults, short circuits, or overloads will trip only the immediate upstream protective device from the point where the fault or overload occurs.

11.2.5 Wiring

- Raceways, ducts, boxes, cabinets, and equipment enclosures shall be designed with respect to their specific applications and in accordance with NFPA 70.
- All insulation shall conform to Article 310 of NFPA 70;
- For tunnel installations, the design and specification for raceways, ducts, boxes, cabinets, cables and wiring and equipment enclosures shall be capable of withstanding temperatures to 932°F and shall not support combustion;
- All insulation shall conform to Article 310 of NFPA 70;
- Wire and cable construction for power circuits to emergency fans shall conform to NFPA 130;
- All conductors shall be enclosed in raceways; and
- Conductors for emergency lighting, communications, and other systems required during emergency operations shall be protected from physical damage from transit vehicles or other normal transit system operations and from fires. Emergency circuits shall not be installed in raceways or ductbanks as circuits powering “normal” loads.

11.3 TRACTION POWER SUBSTATIONS

For requirements for Traction Power Substation Buildings, refer to Section 10.5.

11.4 EMERGENCY POWER SYSTEMS

Emergency power systems shall be designed to provide power to selected systems (at a minimum, to life safety systems) in the event of outage of normal power sources as hereinafter classified:

11.4.1 Emergency Lighting and Requirements

Emergency power and lighting shall be provided at the following locations:

- Enclosed (Indoor or Underground) Public Facilities: Emergency illumination shall be maintained at no less than 0.25 foot-candle at floor level for all egress pathways;
- Exit Signs in Enclosed Public Facilities: All exit signs shall be self-illuminating with battery pack/charger;
- Electrical and Systems Equipment Rooms: Provide minimum 1.0 foot-candle emergency illumination at floor level; and
- Special Systems: Fire detection and other critical systems that require low voltage DC for normal operation shall utilize internal battery DC power supplies.

11.4.2 Emergency Power Sources

For transit and related facilities, emergency power sources shall be selected on the basis of reliability and lowest life-cycle cost. Possible sources may include standby (stationary or portable) generators at transit control centers, maintenance facilities or locations where elevators are present, battery-powered emergency lighting units with remote heads, a central battery system such as an Uninterruptible Power Supply (UPS), and/or redundant isolated power company utility services.

Battery-powered emergency light units shall be employed as required to meet the performance requirements below. Batteries shall be sealed lead-acid type with calcium-alloy grid or other suitable maintenance-free type. Units shall be connected to the branch supply circuit, using direct-wired connections. Attachment plugs and receptacles shall not be used. The branch circuit overcurrent device shall be employed as the disconnecting means.

Battery-powered emergency light units shall employ halogen-type lamps or other modern technology, and shall be capable of maintaining rated illumination for not less than 1½ hours. The chosen lighting will be economical and efficient to operate and maintain. Units shall employ solid state pulse-type charging circuits, which shall recharge battery to fully charged state not more than 12 hours after full-discharge duty cycle.

A solid state switching circuit shall energize the lamps upon sensing AC power loss, and shall de-energize lamps upon either power restoration or when battery voltage reaches a minimum value recommended for extended service life.

11.5 LIGHTING

The lighting criteria contained herein are intended to provide the functional and aesthetic guidelines necessary to design lighting for site areas, passenger stations and appropriate trackway sections. Conformance with these criteria is necessary to insure adequate lighting levels for the system facilities, and provide intended quality, convenience, safety, and efficiency for the LRT system.

11.5.1 Design Objectives

General objectives for station lighting are as follow:

- Promote safety by identifying and properly illuminating areas and elements of potential hazard;
- Enhance the system's visual and functional clarity by differentiating between site circulation networks, station entrances, fare validation areas, and platforms; and
- Reinforce the presentation of graphic messages.

11.5.2 Standard Equipment

All luminaires and lamp types shall be standardized system wide as much as practical to provide design and perceptual unity and simplify maintenance requirements. Lighting installed for the project which will be maintained by an agency or jurisdiction other than Metro Transit shall meet that agency's design standards.

11.5.3 Illumination Levels

Illumination levels shall define and differentiate between task areas, decision and transition points, and areas of potential hazard. In addition to quantity of light, it is essential that illumination be designed to minimize glare and provide uniform distribution. Luminaires shall be selected, located, and/or aimed to accomplish their primary purpose while producing a minimum of objectionable glare and/or interference with task accuracy, vehicular traffic, and neighboring areas.

Lighting design shall consider that which is installed for the project as well as existing or proposed lighting levels from adjacent uses

Recommended illumination levels are shown below:

(Unless otherwise indicated, use a uniformity ratio of 3:1)

<u>Interior Locations</u>	<u>Illuminance Average Horizontal Footcandles</u>
Station Platforms	40
Concessions	40
Staff Rooms	40
Stairs, Elevators, Escalators	25
Mechanical Rooms, Toilets	20
Storage/Custodial Rooms	10
<u>Exterior Locations</u>	
Station Platforms, Covered	7
Station Platforms, Uncovered	4*
Fare Vending Area	10
Parking Lots & Access ways	2
Entrance and Exit Roads	3
Load-Unload, Kiss and Ride, Bicycle Stands	5
Pedestrian Walkways	2
Minor Pedestrian Walkways	2
Outdoor Plazas	5
Bus-Loading Zones	7
Outdoor Entrances to Escalators & Stairways	10
Bus Roadways	3

* Maintain minimum illumination of 2.0 fc at platform edge.

Trackway: The following illumination criterion applies only where supplemental trackway illumination is determined necessary per criteria in Section 11.05.11.

Commercial districts

Average Luminance, 0.8 candela per square foot
Average Illuminance, 12 lux (1.1 footcandle)
Average to Minimum Ratio, 3:1
Maximum to Minimum Ratio, 5:1
Veiling Luminance Ratio, 0.4:1

Intermediate districts (Mixed commercial and residential)

Average Luminance, 0.6 candela per square foot
Average Illuminance, 9 lux (0.8 footcandle)
Average to Minimum Ratio, 3.5:1
Maximum to Minimum Ratio, 6:1
Veiling Luminance Ratio, 0.4:1

At-grade Intersection with Roadway: Average luminance at intersection shall be greater or equal to 1.5 times average luminance of roadway and ratio of average to minimum at intersection shall be less than or equal to 2.5. Roadway lighting is recommended per IES Standards according to Table 2 and shall have a minimum luminance of 0.8 candelas per square meter or an illuminance of 8 lux (.7 fc) for an area extending 100 ft. on both sides of the tracks.

At-grade intersections shall have a minimum vertical illuminance of 1.0 fc at a distance 5 ft. from the centerline of the tracks. The illuminated plane shall encompass the full width of the crossing plus 5 ft. on each side of the roadway and be 15 ft. in height.

Pedestrian Crossing: The lighting design shall provide 1.5 times trackway illumination for 100 ft. before and after crossing, or a minimum of 1.2 fc or 1.7 fc depending on location.

11.5.4 Station Site Lighting

Station site lighting includes internal site circulation and access to the station. The placement of luminaires shall not obstruct the movement of vehicles. Luminaire placement shall be coordinated with the landscape and site plan to protect light standards which are located adjacent to roadways, and to ensure that plantings will not obscure the lighting distribution pattern. See Section 6: Station Area and Facility Requirements for additional information.

11.5.5 Vehicular Access Lighting

Vehicular access lighting shall provide a natural lead-in to the bus areas and Kiss and Rides. The illumination on all access and egress roads shall be graduated up or down to the illumination level of the adjacent street or highway.

11.5.6 Pedestrian Access Lighting

Pedestrian access lighting shall define pedestrian walkways, crosswalks, ramps, stairs and bridges.

11.5.7 Station Platform Lighting

Platform area lighting shall be in Waiting and Loading areas. The lighting elements shall extend the entire length of the platform and shall demarcate the platform and emphasize the platform edge, vertical vehicle surfaces, and landings associated with elevators and stairs. Care shall be taken to avoid "blinding" LRT operators or other vehicle drivers with excessive or misdirected lighting.

11.5.8 Emergency Lighting

Emergency lighting in enclosed indoor and underground transit facilities shall be supplied by a percentage of normally burning luminaires to provide adequate lighting for the orderly egress of patrons and employees during power failure. These luminaires and all exit, egress, and essential directional signage, shall be powered by an emergency power source as described in Section 11.4.1.

Emergency lighting for stairs shall be designed to emphasize the top and bottom steps or landings.

11.5.9 Control of Lighting Systems

Lighting controls installed for the project which will be maintained by an agency or jurisdiction other than Metro Transit shall meet that agency's design standards.

Lighting control shall be designed to use energy efficiently. Automatic and manual control arrangements shall ensure efficient utilization of energy and maintenance procedures. Interior, non-public low usage areas shall be controlled by motion sensing devices.

All exterior site areas shall be illuminated when the ambient daylight drops below 30 fc and all but security site lighting shall be turned off a half hour after revenue service stops. All lighting shall be turned on half hour prior to revenue service commences when ambient daylight is below 30 fc and

automatically turned off when ambient daylight exceeds 30 fc. Provision shall be made for photocell with time clock and manual override. Ancillary areas shall be individually switched.

11.5.10 Trackway Illumination

Trackway illumination is required:

- At all at-grade roadway crossing locations, per IES recommendations; and
- Where safe vehicle stopping distance (emergency braking condition) exceeds night visibility for operating speed using appropriate vehicle lighting (low beam, high beam or train spotlight operation). Note that appropriate vehicle lighting is determined by trackway environment, a function of adjacent roadway, direction of vehicle travel on adjacent roadway, etc. See Section 12.10 for safe LRT vehicle stopping distances. Intrusion mitigation measures may be substituted for supplemental illumination in areas of exclusive right-of-way.

Shielding or other method of glare reduction is recommended:

- Where veiling luminance to average luminance ratio (measuring disability glare) exceeds 0.4 to 1 for trackway section.

Trackway illumination is recommended:

- At all designated at-grade pedestrian crossing locations (e.g., Z crossing configuration);
- Where nighttime pedestrian activity is high adjacent to the tracks and pedestrian crossing locations are not defined; and
- Beneath underpasses to minimize operator discomfort.

11.6 SYSTEMWIDE GROUNDING

11.6.1 General Requirements

Project elements will be grounded as described in this Section. IEEE Standard 142 “Grounding of Industrial and Commercial Power Systems” and IEEE Standard 80 shall be used as a design basis.

11.6.2 Platforms

Grounding for passenger stations shall consist of a ground system termed a “perimeter ground ring”, and shall be provided for each station platform. The ring will be constructed under each facility in native earth and be comprised of buried exothermically welded grid-and-rod system similar to the substation ground mat, which encircles the perimeter of the platform. All metal

components of transit facilities within 15 ft. of centerline of track including shelters, fences, poles (includes OCS poles), guardrails, handrails, ticket vending machines, and bollards that are susceptible to contact by patrons and/or operating and maintenance personnel shall be electrically bonded to the perimeter ground ring with a dedicated “pigtail” exothermically-welded to the ground ring.

Connection to metallic objects on the platforms shall be above ground and visible, and exothermically-welded, except that connections to sheet metal electrical equipment enclosures such as ticket vending machines, may be bolted. Connecting “pig tails” shall have large enough diameter to withstand physical damage. Minimum conductor size for connection to platform equipment shall be 2/0 AWG.

The ground grid shall be designed per IEEE 80 to limit touch potentials and step potentials to safe values in the event of a fault in the vehicle electrical systems, or broken or dropped OCS conductor.

The resistance to remote earth shall not exceed 5 ohms.

The grounding of all electrical raceways, fittings, and equipment shall meet or exceed the requirements of the National Electrical Code and ANSI/IEEE C2, which specifies additional, application specific requirements not covered in the NEC.

11.6.3 Fences

Conductive fencing within 15 ft of the centerline of the track shall be grounded. Where the fence is interrupted by gates, the fence shall be grounded at each side of the gate and a flexible ground strap used to bond the gate to the fence. Fences shall also be grounded at or near the location of a supply line or lines crossing them, and additional, at distances not exceeding 150 ft on either side.

Fences within 10 ft of the substation ground mat shall be non-metallic.

11.6.4 Metallic Objects within ROW

Metallic objects within 15 ft of the centerline of track, including guardrails on bridges, shall be grounded.

Grounding connections shall not be made on mechanical and utility pipes (including water) on the service side of dielectric couplings used to provide an electrical termination point for corrosion control systems.

11.6.5 Ground Mats

The main AC ground mat will be used for grounding the building, conduits, equipment, and for safety grounding.

Ground mats require special consideration for landscaping. The design of the mat assumes that the mat itself is covered with 6 in. of native soil. In addition, the top 6 in. over the mat and to 3 ft beyond horizontally must be covered with clean gravel. Ideally, the gravel produces an insulating layer, which protects people against electrical shock if there is an electrical fault (short circuit) on the system. The gravel limits the electrical voltage for either a "touch potential" or "step potential," and is necessary for conformance with IEEE 80, the design criteria for this and other substation projects. Landscape architects should be careful to comply with this requirement. In addition, care should be exercised not to contaminate the gravel from shrubs or other plantings. The use of a fabric to isolate the earth from the gravel is encouraged.

Where paving covers the mat, care should be taken to cover the mat first with 6 in. of compacted gravel, $\frac{3}{4}$ in. minus or equivalent. This will provide the isolation required.

Refer to Section 10 for further requirements on ground mat construction.

11.6.6 Ground Tests

Fall of potential ground resistance tests per IEEE 81 "IEEE Guide for Measuring Earth Resistivity..." shall be made on station platform ground rings, and substation ground mats, before the mats are covered. The following tests are required:

- Substation Ground Mats:
 - Resistance to remote earth of AC mat per IEEE 81 Fall of Potential Method;
 - Resistance to remote earth of DC mat per IEEE 81 Fall of Potential Method;
 - Resistance between AC and DC mat – IEEE 81 Two Point Resistance Test; and
 - Resistance between Substation Utility Ground Rod and Electric Utility
 - Grounding System – IEEE 81 Two Point Resistance Test;
- Station Platform Ground Rings:

Resistance to remote earth of ground ring per IEEE 81 Fall of Potential method

Test reports shall be furnished.

11.7 CONDUIT AND DUCTBANKS

11.7.1 Scope

This section applies to all raceways and underground ductbanks for traction power, signals, communications, low voltage and high voltage (15kV) AC including station platforms, systems buildings and Park and Ride stations.

11.7.2 General Requirements

All wire and cable shall be protected by raceway, except for low voltage signal or communication wiring where protected from physical damage by any means.

Traffic signal interconnects and communications shall be run in separate conduits, isolated from LRT control systems and run to dedicated handholds at each signalized intersection.

Raceways shall be galvanized rigid steel conduit unless indicated otherwise in the following paragraphs. Raceways below grade shall be galvanized rigid steel conduit provided with suitable corrosion protection. Acceptable corrosion protective coatings may be either coal-tar epoxy or factory-applied PVC (PVC-GRS), continuous for the entire embedded or buried portion plus a minimum of 12 in. on each end.

EMT conduit may be used inside, in dry locations, where not subject to physical damage such as in substation building, or signal and communications buildings.

PVC Schedule 40 conduit may be used only in underground concrete encased ductbanks or where otherwise indicated. PVC conduit, type EB may be used only in straight sections of concrete-encased ductbanks. Installation of PVC conduit is subject to bending radius limitations as follows:

- All conduit bends 30 degrees or more shall be PVC/GRS except bends in ductbanks with radius greater than 6 ft may be PVC, Schedule 40. PVC Schedule 40 bends shall be factory-made or field-made using an approved hot-bending appliance; and
- Bends in concrete encased ductbanks greater than 100 ft radius may be made by sweeping either schedule 40 PVC or type EB. Type EB conduit shall not be hot-bent.
- All conduits shall pass a mandrel test for minimum size as described by the NEC for that given conduit dimension.

Where large cables are to be installed in raceway, the bending radius of the raceway shall be no less than 12 times the cable diameter. Minimum bend

radius for raceways a nominal 2 in. and larger installed below grade shall be as follows:

Nominal Conduit Size (inches)	Conduit Bending Radius (inches)
2	24
2½	27
3	30
3½	33
4	36
5	42
6	48

Raceways shall be limited to a maximum of 270 degrees of bend between manholes, handholes, junction boxes, or termination points.

A minimum 20% spare raceways shall be provided, except where determined that spare capacity is either not necessary, or that undue expense would be incurred.

11.7.3 Concrete Encased Ductbanks

Ductbanks are constructed of raceways, usually type PVC conduit, concrete encased, with reinforcing steel at grade crossings and elevation changes. The exact dimensions vary with the number and size of raceways, but in most cases consist of a central core of raceways assembled with manufacturer's standard spacers to allow a minimum 1½ in. of space between raceways for signal/communications ductbanks and 3 in. for power. The outside envelope consists of a minimum of 3 in. of concrete on all four sides.

The ductbanks are set on a prepared and compacted bed of compactable gravel or sand, usually 3 or more inches in depth. The concrete for the ductbanks will be of strength and quality to withstand the load at any specific depth or configuration necessary. A maximum of 16 raceways will be permitted in any one ductbank where terminated in a single handhole or manhole.

Except in special cases, systems ductbanks will be located longitudinally along the length of the track and between the tracks. Where special conditions require, ductbanks may be located along the outside of the tracks, or in any adjacent area as required by the special circumstances.

Lateral crossings underneath the tracks are permitted, but should be minimized. Where necessary, the ductbank may be located directly under the

tracks longitudinally, but in no case may a manhole or handhole be located between the rails.

Where obstacles such as pole bases are encountered, the ductbank will be gradually offset around the structure, and at all times retain the minimum dimensions of the envelope and structural integrity.

System ductbanks will be located generally in plan and profile. Ductbanks will be sloped to drain to manholes or handholes, and located to avoid interference by existing utilities, and will provide cover in accordance with the appropriate NEC guidelines, and at the same time not require excessive manhole or handhole depths.

Manholes and handholes shall be of the pre-cast type, complete with cable supports, and pulling irons. Where manholes or handholes are installed, a ground rod shall be driven, and all metallic parts grounded. Where installed in streets or traveled roadways, Manholes and handholes shall be equipped with a traffic-rated cast iron cover with grade ring, cast polymer covers or combination as needed to achieve H20 load rating for any specific installation, Manholes and handholes will be necessarily adjustable to meet the final grade at any given site. In other locations, covers may be welded steel, cast concrete or cast iron as needed.

11.7.4 High Voltage AC Conduits and Ductbanks

If high voltage (greater than 600V) AC feeders are used, they shall be run in galvanized steel or PVC conduits, and the conductors separated from other systems.

If required because of electromagnetic interference (EMI), high voltage AC conductors shall be run in galvanized rigid steel conduit, or other means taken to mitigate the effects of EMI.

High voltage AC conduits shall have a bending radius no smaller than 36 in.

11.7.5 Station Platforms

For station platforms, raceways shall be PVC/GRS embedded in fill 3 in. minimum below the platform slab. Junction and pull boxes shall consist of concrete handholes set in the rough concrete slab and matching cast iron sidewalk topping boxes with bronze covers set flush with the finished platform surface. All conduit penetrations into the concrete handhole shall be horizontal and provided with insulated bonding bushings and bonding jumpers. The topping box shall be bonded to the raceway system with #6 AWG minimum bare stranded copper jumper cable.

11.7.6 Park and Ride Lighting and Street Lighting

For Park and Ride lot lighting and street lighting, raceways shall be PVC, Schedule 80, and direct buried 36 in. below grade. PVC to GRS shall be used where raceways transition for all bends. Shallower depths may be allowed, refer to, and incorporate, local jurisdictional requirements for exceptions.

11.8 PLATFORM HEATING

11.8.1 Platform Radiant Electric Heat

Platform electric heat shall be rated either 208, 240 or 480 VAC, and suitable for outdoor, damp environments. Heaters shall be corrosion resistant and fabricated from either aluminum alloy or stainless steel. Heaters shall be equipped with an integral or remote mounted thermostat, and the elements guarded to protect the public from inadvertent contact. Heaters shall be mounted a minimum of 8 ft above the finished platform, but be placed as high as practical and functional.

Heater control circuits shall not exceed maximum of 2 heaters.

12.0 SIGNAL SYSTEM

12.1 GENERAL DESCRIPTION

Railway signaling equipment shall be applied at various LRT locations to enhance safety in the movement of trains and to improve the overall efficiency of train operations. These functions include the protection and control of track switches; the protection for following trains operating with the normal current of traffic; and roadway grade crossing warning.

The need for signaling, and the type of signaling provided, shall be determined by the specific requirements of each line segment. In general, the Signal system configuration shall allow the entire system a full-featured bidirectional operation on both main tracks.

The wayside signals governing entrance to interlockings are absolute, semi-automatic stick signals.

Continuous Track Circuits will be used in open track areas where maximum allowable speeds are above thirty miles and hour, or where LRV track segments are governed exclusively by Train Signals. An electrical circuit which uses the track rails as the conductors between transmit and receive devices, the limits of which are commonly defined by the location of insulated joints. The primary purpose of the track circuit is to detect an occupancy or interruption. It may also be used to convey information.

NOTE: Upon successful completion of a safety and reliability study, track circuit overlay equipment utilizing wheel counters may be used to provide train detection on roadway crossing islands and other block indication tasks.

At stations and interlocking entrances system wide will use Train to Wayside Communications (TWC) systems to provide non-vital signal requests and other non-vital information to the Rail Control Center. Specific functions provided by the TWCs will include:

1. Automatically calls the “Automatic Route” through interlockings; the same interface can cancel and recall routes and alternate routes at any home interlocking signal;
2. Cancel and re-request Gated crossing equipment activation to reduce the impact of train movements and delays in street intersections;
3. Update the Rail Control Center (RCC) computer system for train locations, train numbers, car numbers, and destinations for any/every trains automatically; and
4. Provide train location to traffic controllers for priority and preemption of roadway traffic intersections.

12.2 AUTOMATIC TRAIN PROTECTION

Automatic Block Signaling (ABS) shall be installed at certain locations along the LRT right-of-way to permit higher operating speeds than would be possible by relying on line-of-sight operation without signals. The ABS signals shall provide information to train operators concerning the condition and occupancy of the track ahead.

High signals with 8-3/8" lenses, snow hoods, and backgrounds shall be used on mainlines in open track territory and other locations where prescribed. Signals located in yards, tunnels, at station platforms, or in urban embedded track environments where mounting space is a concern shall be 6-3/8" transit-type signals. Signals may have one or two heads, as appropriate. At locations where more than one alternate route is available, signals may have a track number indicator, as appropriate.

All signals shall be controlled by continuous track circuits extending throughout the block. All signals shall be controlled, in regard to any track switch in the block to display a red aspect when:

- The switch points are not in position for safe train movement;
- A hand-operated switch is not in the normal position;
- A switch-and-lock movement is not fully locked;
- An electric switch-locking movement is not fully normal; and
- The selector lever of a dual-control switch-and-lock movement is not in the "MOTOR" position.

No signal shall display an aspect less restrictive than approach, when the next signal, in advance, displays an aspect requiring a stop. Three-aspect, non-interlocked signals shall display a "proceed" aspect when the next signal, in advance, displays an approach aspect.

12.3 INTERLOCKINGS

Interlockings shall be provided for all power switches and movable-point frogs used on the mainline. Interlocking signals shall be provided to govern train movements into and through interlocking limits.

Detector, time, route, traffic, and indication locking shall be provided at all interlockings. Detector locking shall not be released until five seconds after the appropriate track relays have closed their front contacts.

All non-interfering train movements, through interlockings, shall be permitted simultaneously.

12.4 ROADWAY GRADE CROSSING WARNING

Warning devices for roadway grade crossings shall be installed at certain locations. Each such crossing shall include automatic gates, flashing lights, bells,

signs, approach and island track circuits, emergency batteries and associated circuitry, cabling and cases.

The design of each crossing shall be specific to that site and shall provide a minimum of 20 seconds warning time, from the time that the lights first begin to flash until the time that a train traveling at track speed enters the crossing. The design of the crossing circuitry shall avoid unnecessary delays to motorists. Where necessary, the grade crossing warning system shall preempt adjacent traffic lights to avoid automobiles forming a queue across the tracks.

Roadway grade crossing warning devices shall be installed consistent with Mn/DOT standards as shown on Figures 12-1 through 12-4.

12.5 TRAIN-TO-WAYSIDE COMMUNICATIONS (TWC) SYSTEM

Metro Transit's LRT cars shall be equipped with a Train-to-Wayside Communication (TWC) system. The car-carried portion of the TWC system consists of two transponders (one for each end of each LRV) and two car control units (one for each cab). The wayside portion consists of an antenna and a wayside transceiver. The wayside transceiver, through the wayside antenna, will constantly transmit a message asking that any car-carried TWC transponder in the immediate area identify itself. A car-carried TWC transponder receiving this message will respond by transmitting a message, identifying the car number, the train number, route number (destination), and other information. Thumb-wheel switches and push buttons in each cab are provided to Train Operators to enter the route number and train number of there consist and other requests such as switch call and preempt call.

A compatible TWC system shall be installed at all interlockings, at all passenger stations adjacent to roadway crossings, and at selected power switches in the yard to allow Train Operators to enter switch call requests. Use of the TWC system shall be the primary method of entering route and switch requests at those locations and the TWC shall be used to provide to SCADA route, train, and car information for a train consist to the control system and the Supervisory System.

12.6 STANDARDS AND CODES

The signal system shall be designed, constructed and tested to the latest revision at the time of award of contract of the following codes and standards:

- U.S. Code of Federal Regulations (CFR), Title 49, Part 236;
- Association of Railway Engineering and Maintenance-of-Way (Formerly AAR);
- Signal Manual of Recommended Practice:
 - American Railway Signaling Principles and Practice;
 - Communication Manual of Recommended Practice; and
 - Typical Circuits Representing Current Practice for Railway Signaling;
- Rules and Regulations of the Minnesota Department of Transportation;

-
- American Railway Engineering and Maintenance of Way Association (AREMA);
 - National Electrical Code (NEC);
 - National Electrical Safety Code (NESC);
 - Institute of Electrical and Electronic Engineers (IEEE);
 - Insulated Cable Engineers Association (ICEA);
 - U.S. Department of Transportation, Federal Highway Administration, Manual on Uniform Traffic Control Devices; and
 - National Fire Protection Association (NFPA) 130.

12.7 SAFETY DESIGN

Train safety shall be the prime consideration in the design of the signal system and in the selection of its components, including relays and other devices with moving parts, insulated wire, wire terminals, binding posts, housings, conduits, resistors, capacitors, transformers, inductors and other similar items. The entire signal system shall meet the requirements of this section.

Circuit design shall conform to the "American Railway Signaling Principles and Practices" of the AREMA AAR Communication and Signal Section.

In this section the terms "restrictive" and "permissive" are used in connection with the binary outputs of two-position components or subsystems and denote such alternatives as: stop and proceed, a lower speed and a higher speed, deceleration and acceleration, brakes applied and brakes released, actuation of alarm and no actuation of alarm, respectively.

The following requirements shall govern the design of the portions of the system or a subsystem which affect train safety:

- Only components which have high reliability and predictable failure modes and rates and which have been proven in conditions similar to the projected service shall be utilized;
- Components shall be combined in a manner that ensures that a restrictive rather than a permissive condition will result from component failure;
- All circuits which are not confined to one housing and which affect safety shall be double-wire, double-break, except signal and switch indicator light circuits.
- The design shall be based on closed circuit principles;
- Component or system failures shall cause a more restrictive signal indication than that permitted with no failure;
- System safety design shall be such that any single independent component or subsystem failure will result in a safe condition. Failures that are not independent (those failures which in turn always cause others) shall be considered in combination as a single failure and will not cause an unsafe condition;

-
- Electronic circuit design shall insure that the following types of component failures have a restrictive rather than a permissive effect:
 - Two terminal devices: open, short, partial open or short; and
 - Multi-terminal devices: combination of opens, shorts, partial opens and/or partial shorts; and
 - Redundant design by itself shall not be considered an acceptable method of achieving design safety.

12.8 HEADWAYS AND BLOCK LAYOUT

A minimum of a three-aspect signal is required to provide information about the aspect displayed by the next signal ahead so as to avoid the necessity for always approaching it prepared to stop. Full and complete signal aspect and configurations are shown in the table in Part 12.13.3 of this document.

Wherever it is displayed, a stop indication shall be an absolute signal, requiring that train operators bring their trains to a full stop and call the LRT dispatcher for authorization to pass the signal at restricted speed (i.e., prepared to stop short any train or obstruction).

Where governed by signal territory as delineated by the full installation of continuous track circuits, this signal system design will provide for practical operational line headway of 5.0 minutes assuming the most restrictive of the vehicle design criteria for the existing LRV fleet. The calculations will assume a 20 second station dwell time for intermediate stations and the car performance described in the “LRV Design criteria” as well as to match the performance of the existing fleet.

12.9 SAFE BRAKING DISTANCE

Safe braking distances shall be calculated using a two second vehicle reaction time, a minimum adhesion which would allow a deceleration rate on level tangent track of 1.95 mphps, and a 35% (distance) safety margin. The assumed deceleration rate shall be reduced on downhill grades to compensate for the effects of gravity. In addition, all safe braking distance calculations in open-track territory shall assume a 59 mph LRV entry speed.

12.10 ENVIRONMENTAL CONSIDERATIONS

All equipment shall be designed to operate from a minimum temperature of -40°C (ambient) to a maximum temperature resulting from a combination of an ambient temperature, maximum sun loading, and maximum normal internal heat generation, of 60°C.

12.11 SERVICE PROVEN EQUIPMENT AND DESIGN

All signal equipment shall be proven in similar North American railroad or transit service. The signal system shall have an expected service life of 40 years at the specified level of service. Achievement of this useful life shall be through the use

of off-the-shelf proven hardware. Each major component shall incorporate provisions to allow for functional and physical interchangeability of replacement spare parts.

12.12 TRAIN DETECTION

Train detection in the ABS line sections and at interlockings in open track and paved track sections shall be by Single-rail, shunt-type 60 or 100 Hz AC track circuits track circuits in conjunction with Insulated rail joints, traction power impedance bonds proper and adequate rail signal and traction bonding as shown in the approved drawings. As an alternate configuration, audio frequency mainline track circuits or electronic coded AC track circuits maybe used in open track areas where insulated joint designs are undesirable.

Single-rail, shunt-type 60 or 100 Hz AC track circuits shall be used to detect train presence on and near powered track switches in the storage yard and within interlocking limits.

Any track circuit listed in this specification that uses known fail-safe equipment, logic or techniques may be used, in the appropriate combination, for train detection in the control of roadway grade crossing warning equipment.

Slow pick-up track repeating relays shall be installed for all track circuits and track relay contacts shall not be used in circuits affecting safety.

The design of the LRV propulsion and traction systems and selection of track circuit frequencies and modulation schemes shall be coordinated to preclude interference between the LRV and the signal system. The impact of Electromagnetic Interference from commercial power lines will also be considered in the selection of track circuit frequencies and modulation schemes.

A shunt with a resistance of 0.25 ohm at any point between the two rails of any track circuit shall cause the track circuit to indicate train occupancy. Shunt fouling shall not be allowed, and multiple track relays shall be used for all turnouts, with the exception of the two (or four) turnouts used in crossovers between mainline tracks. Voltage regulating transformers in the feed to the track may be used or additional track circuits may be installed, if necessary, to provide this shunting capability; however, special (tuned) impedance bonds shall not be used.

For Non vital applications in rail segments where shunting problems are anticipated, such as embedded rail or roadway crossing panels, systems that use wheel sensing and axle counting technologies are acceptable to Metro Transit. These specific instances will replace the traditional “traffic loops” and be used for the purpose of roadway traffic priority requests and train location for intersection traffic control systems.

12.13 SIGNALS & SWITCH INDICATORS

12.13.1 Color Light Signals

With the exception of those signals noted below and one-aspect interlocking signals, standard railway color light, high signals, including backgrounds, ladders, and maintenance platforms, shall be provided for ABS sections and interlockings in open-track sections. Signals at station platforms, which do not have to be viewed from a distance, shall be transit-type, color light signals on pedestal bases. Transit-type color light signals shall be wall mounted in tunnel sections.

12.13.2 Switch Indicators





Railway-type, color-light interlocking signals shall be provided at all mainline switches in ABS rail sections. Available aspects will conform to the operating procedures rule book and the indication and aspect table shown in Segment 12.13.3.



Railway-type, color-light position indicators will be provided at yard powered switches. Each switch indicator shall display a green indication if that particular switch is lined and locked normal and yellow if the switch is lined and locked reverse.

12.13.3 Signal Aspects

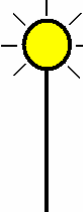
All color light signal controls will be compatible with the aspect and indication chart shown below:

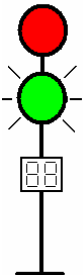
12.13.3.1 SIGNAL ASPECTS AND INDICATIONS, COLOR LIGHT & BAR SIGNALS

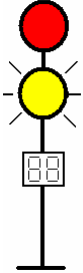
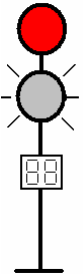
<u>Name & Rule No.</u>	<u>Aspect</u>	<u>Aspect</u>	<u>Indication</u>
Stop	Red		Stop.
Approach	Yellow		Proceed prepared to stop at next signal / Entering dark territory.
Approach Diverging	Flashing Yellow		Proceed to next signal, prepared to enter diverging route at prescribed speed.
Clear	Green		Proceed. (Next signal is permissive.)
Diverging Clear	Red over Flashing Green		Proceed on diverging route at prescribed speed through turnout. (The next signal is permissive.) Track Number Indicator, where provided, will indicate destination. (See Note 1)

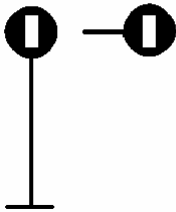
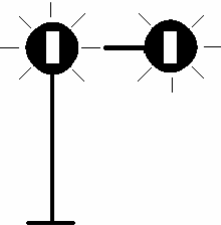
Diverging Approach	Red over Flashing Yellow		<p>Proceed on diverging route at prescribed speed through turnout. Be prepared to stop at next signal / enter dark territory.</p> <p>Track Number Indicator, where provided, will indicate destination. (See Note 1)</p>
Diverging Restricting	Red over Flashing Lunar		<p>Proceed at restricted speed on diverging route at prescribed speed through turnout, entering either an occupied block or yard limits.</p> <p>Track Number Indicator, where provided, will indicate destination. (See Note 1)</p>
Restricting	Lunar		<p>Proceed at restricted speed into an occupied block, or within yard limits.</p>
Vertical Bar	White Vertical Bar		<p>Proceed through roadway intersection.</p>
Flashing Bar	White Flashing Vertical Bar		<p>Proceed prepared to stop.</p>

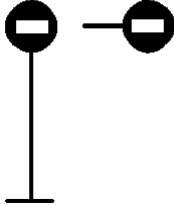
Horizontal Bar	White Horizontal Bar		Stop.
<p>NOTE 1: Signals capable of displaying diverging aspects with more than one possible alternate route shall be equipped with LED track number indicators, displaying to the train operator which track they are lined to. (e.g. 1, 2, or Y for Yard)</p>			

12.13.4 Light-Out Protection

Light Out Protection shall be provided on all wayside signals to prevent a dark or improperly displayed aspect due to a failed lamp or broken wire. Any signal whose aspect is downgraded to a Stop or dark indication shall break the “D” to the signal to the rear, so an Approach is displayed prior to the Red or Dark signal.

12.13.5 Signal Locations

In open track and dedicated ROW, signals shall be located to the left of the track segment governed without exception.

Where center running rail in the median of an operating street, Side by Side signals are acceptable where the overall dimensions do not exceed 90 inches above TOR or 27.5 inches in overall assemble width, in accordance with the clearance needs of the specific application.

In locations where only a single Signal is necessary, a “Double Signal” will be create with a Blank plate to eliminate the possibility that an Operator might misinterpret which track is to be governed by that signal.

12.13.6 Signal Height

All signals governing normal movements shall be as close to the Train Operator's eye level as practicable.

12.13.7 Signal Lighting

Signal lighting shall be DC, continuously-lit, LED heads from an industry recognized manufacturer.

Under special circumstances, approach lighting may be used and signal lights may be extinguished when there are no trains in position to view the signal. Otherwise, it is expected that all vital train signals will be lighted continuously.

12.13.8 Bar-type Signals

Bar-type signals shall be used in paved-track areas and other low speed areas, as specified, for intersection traffic operation only, not used as wayside signals as part of ABS or Interlockings.

Bar Signals are not allowed as the sole or primary LRV operating indication in any circumstance where mainline speeds are greater than 35 MPH

12.13.9 Signal Numbering

All LRT signals shall have number plates attached to facilitate identification and simplify record keeping.

To accommodate a system with multiple operating lines, an alpha numeric numbering system will be required for signal numbering that is simple and direct.

Signals may be temporarily removed from service only as prescribed by the Metro Transit Light Rail Rule Book.

12.13.10 Signal Operational Signage

All ABS track segments, where ABS is in use, will include 'BEGIN ABS' and 'END ABS' signs and shall be installed at the beginning and end of ABS limits.

All interlocking track segments will include 'BEGIN INTERLOCKING LIMITS' and 'END INTERLOCKING LIMITS' signs and shall be installed at the entrance to and exits from each interlocking.

'BEGIN BI-DIRECTIONAL LIMITS' and 'END BI-DIRECTIONAL LIMITS' signs shall be installed in areas where signalized bidirectional operation is possible. All new design will, by default, be designed to accommodate full bidirectional operation unless impractical or otherwise accepted as unnecessary do to a local condition or constraint, such as "single track" operation.

The above signs shall be Yellow Scotchlite[®] with black borders and block, capital letters.

12.14 MAINLINE TRACK SWITCHES

12.14.1 Track Switches in Open-Track

12.14.1.1 Manual Track Switches

Signal logic and Track circuit configuration will be designed to support a “Quick release” function at points of electric locked hand throw switches. This function and logic will allow an LRV stopped at the switch points to release the electric lock, and allow the switch throw, without running the necessary time locking required to assure that any train that may have entered this block under a clear signal will have time to clear or react to this new condition.

The switch lock will be released without running time if opposing approaches are clear, all entrances to that track segment are at Red and no trains are in approach to those signals that have been slotted to red. This additional functionality will allow more flexible emergency operations while maintaining safe signal and operational practices.

12.14.1.2 Powered Track Switches

Switches shall be powered by dual control (motor driven/manual) switch machines on open trackwork. Power for the dual control switch machines shall be from commercial 120 VAC power source with rectifiers and 110 VDC batteries. Switch machines shall be equipped with operating rods, lock rods and point detectors.

12.14.1.3 Switch Heaters

Switch heaters shall be provided at all mainline switch locations in open track, all yard powered switch locations, and at all powered switches in paved track.

Switch heaters will be capable of creating an ice free environment for all conditions possible in Minnesota. Switch point heaters and crib heaters will be required. Heating elements will be installed in either 400 watts per foot or as necessary to create an ice free environment in ballasted, direct fixation or embedded track areas according to location specific conditions.

For any switch heater installation, the design must allow replacement of the heating elements without disruption to the civil or track work around the switch.

Switch heaters will be typically powered from the OCS power located near that crossover. Remote RCC control will be available as well as local disconnect and local control through the local devices.

12.14.2 Track Switches in Paved Track

12.14.2.1 Manual Track Switches

Manual track switches shall be equipped with toggle type switch movements. Facing-point switches in signaled territory shall be equipped with switch circuit controllers.

12.14.2.2 Powered Track Switches

Powered track switches shall be equipped with operating solenoids and switch circuit controllers. Modern, reliable component based Motor/Hydraulic switch machines may be used.

12.14.3 Powered Yard Switches

Powered yard switch operating mechanisms shall be dual-control (hand and motor), electrically operated, trailable devices. Two direction switch indicators shall be provided, either integral to the machine or on a separate mast.

12.15 CONTROL CIRCUITRY

All circuits affecting train safety shall be controlled by vital relays in compliance with Section 6.2 of the AREMA (AAR) Signal Manual. Non-vital logic circuits shall be controlled by non-vital relays in compliance with Section 6.3 of the Signal Manual.

All relays shall plug into separate relay bases. All non-vital relays shall be identical. All relays shall be furnished with at least one spare independent front-back contact.

The use of diodes, capacitors, or resistors to change a relay's timing characteristics shall not be allowed. All such timing characteristics shall be accomplished magnetically.

Vital microprocessor interlocking equipment may be used.

12.16 SIGNAL POWER

12.16.1 Power Line

Delete original section

12.16.2 Frequency Converters

Delete original section

12.16.3 Batteries

All signal and grade crossing warning equipment shall be supplied with emergency batteries. Nickel Cadmium batteries shall be provided. Solid-state transit-type inverters shall be provided to supply power to AC loads such as track circuits during power failure.

All wayside signal system equipment will be provided with battery backup sufficient to provide normal revenue operations for a minimum period of eight hours. Power distribution schemes utilizing two “independent” utility feeds are not acceptable for signal equipment.

For AC track circuits and any other components for which DC backup is not possible, an inverter would be provided for emergency power supply off the DC battery bank, with the design of the battery system to accommodate this additional load. Switch machines will have their own B110 bank.

For extended outages, a generator receptacle and appropriate change-over switches should be provided on each location where vital signal equipment operates.

12.17 LOCAL CONTROL PANELS

Local control panels shall be installed at all interlockings, either as a hardwired Panel or an electronic Man-Machine Interface as proposed. Either device can be provided with a serial interface or with discrete I/O as necessary to accommodate the equipment chosen for vital and non-vital applications..

The panels shall be rack-mounted and include a track model with lighted graphic indications for each track circuit, switch, signal and unique condition, such as “gate activation” or “switch heat” indication, etc, according to location. These lights shall include track occupancy (detector, approach, and leaving circuits), switch condition (normal, reverse and locking), signal aspects, and route requests stored.

The panels shall also possess the capability to generate and cancel any request for signals, to position switches for a movement that can be generated from other locations in the associated interlocking, and the capability to operate each power switch or crossover individually. Panels shall contain a key-locked switch or password protected interface that must be unlocked before control is transferred from the TWC system and Rail Control Center to the panel.

12.18 EVENT RECORDERS

Solid state event recorders shall be installed in each signal equipment room, either as part of the solid state vital controller or as a separate device that is approved by the Metro Transit Rail as well as compatible with the Metro Transit SCADA archive and reporting systems. This device will demonstrate a successful history and be currently in use in the US Rail transportation industry. These event

recorders shall record the status of each track circuit (occupied or not), each signal (all aspects), each switch or crossover (normal, reverse, or not in correspondence), and each route request (requested or not).

Additional data can and will be added to event recorder records to accommodate the needs of maintenance, security and rail operations as noted in the specifications.

12.19 SCADA INTERFACE TERMINAL BLOCK

Each signal equipment room and each signal equipment case shall be equipped with a SCADA interface and associated terminal block. The SCADA terminal block shall be provided to interconnect the SCADA system with the status of the interlocking, tracks, switches, signals and the TWC route request, etc.

The SCADA system will be capable of providing any necessary binary or serial data connection between and two signal locations , the RCC, or any other terminal on the Data Backbone.

12.20 LIGHTNING AND TRANSIENT PROTECTION

Track circuits shall be protected from lightning per AREMA (AAR) Signal Manual Part 11.2.1. Grounding electrodes shall be provided and installed in the signal rooms. Ground rods shall also be installed at all signal cases. Connections between arresters, other signal equipment, and grounding electrodes shall be per Signal Manual Part 11.1.1, except that all connections to grounding electrodes shall be by exothermic welding.

Primary, Secondary, and Tertiary protection shall be provided, especially as it relates to electronic equipment. All electronic and solid state devices shall have effective internal and separate external surge protection. High-voltage lightning arresters shall be applied to commercial power connections.

12.21 WIRE AND CABLE

Station to station and signal room or house to field equipment signal wires in the signaled areas shall not be combined in the same cable or conduit with signal power or communication circuits. In general, conduit located in an underground duct bank shall be provided.

Station to station and signal room or house to field equipment signal conductors shall be insulated #14 AWG or larger conductors. Multiple conductor cables shall have an outer jacket.

Case wiring shall be insulated #16 AWG or larger.

Wire, cable and its installation shall comply with the applicable requirements of the AREMA (AAR) Signal Manual. A minimum of 10%, but not less than two spare conductors, shall be required in each cable.

12.22 LOCATION OF SIGNAL EQUIPMENT

Signal system equipment shall be located in wayside houses. Wayside cases shall be used for signal and communication equipment where environmental control is not a consideration for the equipment housed therein..

A ventilated signal/communication room will be provided only in the tunnels as required by applicable codes..

All signal equipment, including signals, switch machines, switch indicators, cases, and houses shall clear the LRV Clearance Envelope as calculated for any specific installation. Exceptions to this may be allowed where right-of-way is restricted and vehicle speeds are minimal.

Doors of signal equipment cases and houses shall be restrained from opening to a position less than 6 in. from the LRV dynamic outline.

Equipment houses or cases shall be located in such a way as to not obstruct the train operators' or motorists' (insofar as grade crossing warning equipment is concerned) view of the governing signal.

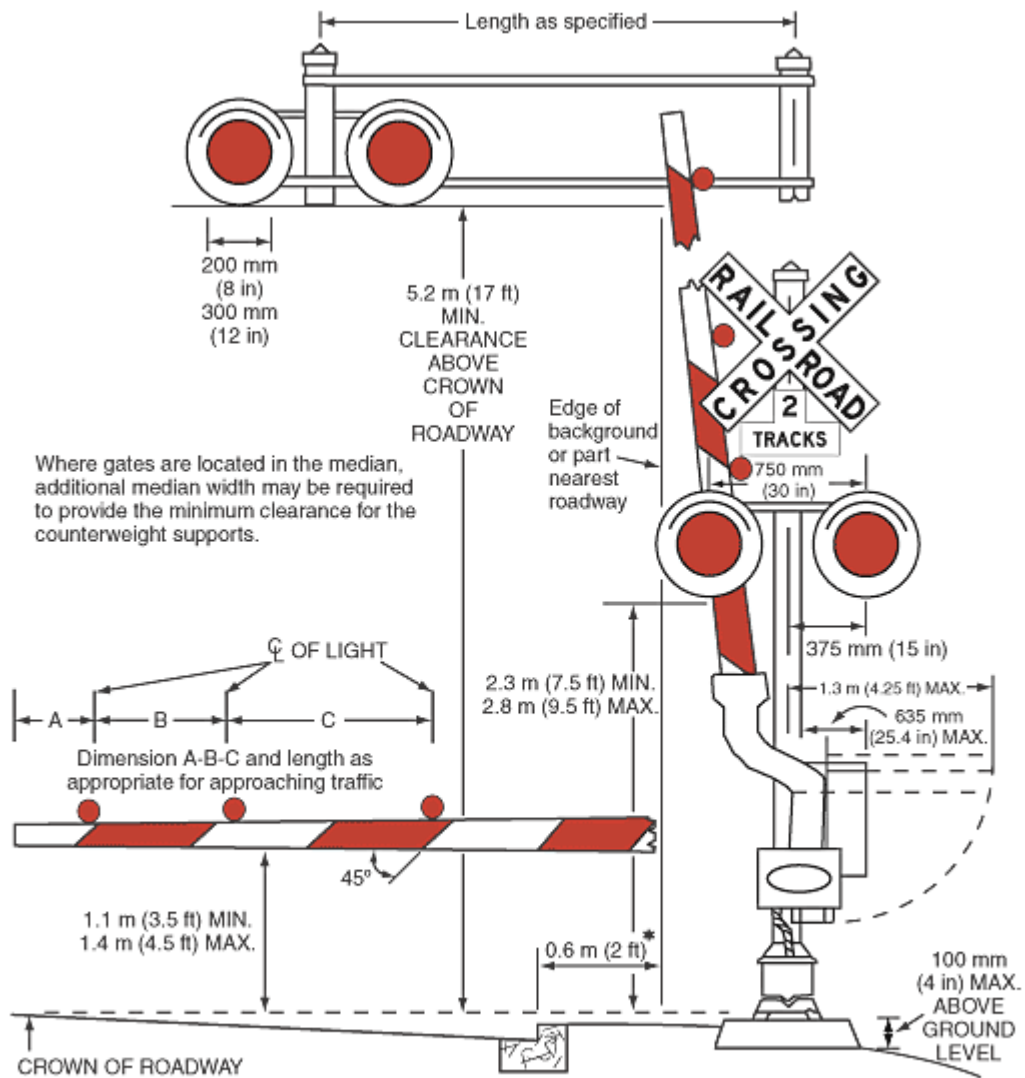

* For locating this reference line at other than curb section installation, see Section 8D.01.

Central Corridor Light Rail Transit

Figure 12-1

Design Criteria

CANTILEVERED FLASHING LIGHT SIGNAL





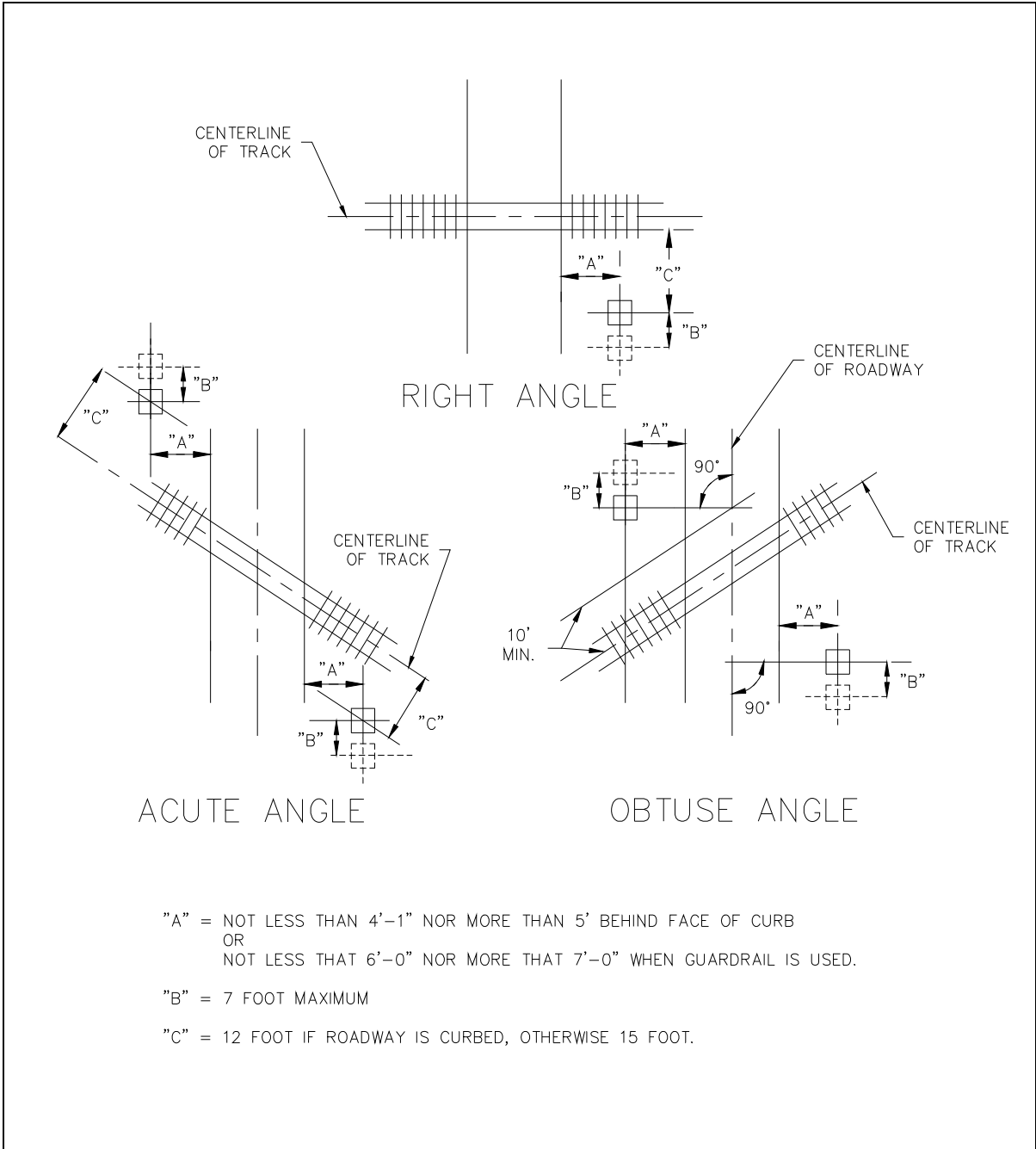

Central Corridor Light Rail Transit	Figure 12-2
Design Criteria	EXAMPLE LOCATION PLAN FOR SIGNALS

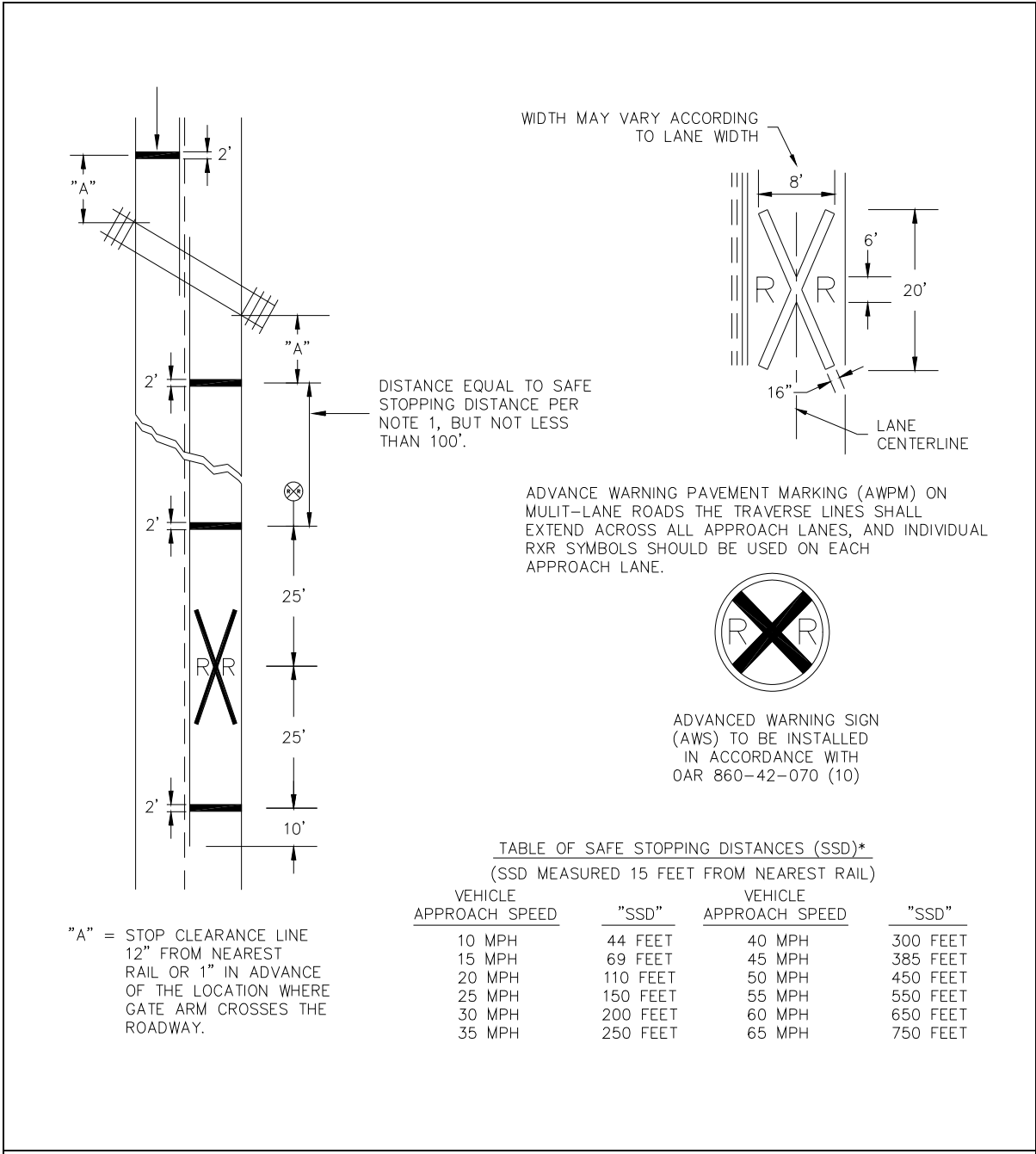

Central Corridor Light Rail Transit

Figure 12-3

Design Criteria

SIGNAGE

13.0 COMMUNICATIONS & CENTRAL CONTROL

13.1 GENERAL

The Communications System includes a variety of communications subsystems and human interface systems to facilitate control and monitoring of train traffic, track conditions, traction power substations, station facilities and tunnel support facilities. The scope includes:

- A Central Control System (CCS) with supervisory control and communications equipment, to allow Metro Transit LRT Operations personnel to remotely monitor and control Metro Transit trains, stations, traction power substations, fare collection equipment, passenger elevators, and other LRT systems;
- A Supervisory Control and Data Acquisition (SCADA) System interconnecting Metro Transit's Rail Control Center (RCC) with all passenger stations, signal equipment rooms and cases, communications equipment rooms and cases, passenger elevators, traction power substations, the LRV storage and maintenance yards, and tunnel facilities;
- Radio consoles and control equipment to be used at the RCC;
- A Closed Circuit Television (CCTV) system to allow Metro Transit personnel at the RCC to monitor the following areas: Yard, station platforms, Tunnel, Bridge Access, and critical LRT approaches and/or segments.;
- A digital fiber-optic-based Cable Transmission System (CTS), to carry Metro Transit voice and data along the length of the LRT system;
- A fiber-optic-based Cable Transmission System (CTS) to carry Metro Transit video along the length of the LRT system, connecting selected LRT facilities with the RCC;
- Tunnel Radio System to facilitate radio communications with Metro Transit trains, Metro Transit personnel, and emergency personnel within underground stations and tunnels;
- Public Address (PA) Systems at all passenger stations;
- Readerboards and interface equipment at all passenger stations to allow the visual, text, display of passenger information;
- An emergency phone system, which shall cause a visual and audible alarm at the RCC;
- A Local Area Network carrying Metro Transit's Information System computer network shall be distributed to certain stations, facilities, TPS and all signal and communication equipment system wide.
- Panels at the Tunnel Command Post to provide access to tunnel ventilation systems, overhead catenary control, fire management information, track occupancy, emergency and PBX telephones, and PA and readerboards;

-
- A Local Area Network distributed to all passenger stations, providing a data connection between the control center and each stations' fare collection equipment data network;
 - Data circuits between each Train-to-Wayside Communication (TWC) unit and the CCS equipment; and
 - A PBX telephone system for employee use at station platforms, equipment rooms, operations rooms, and at certain facilities. Emergency telephones shall be a part of this system, with emergency telephones at tunnel and other locations. This telephone system shall be integrated with the existing Metro Council telephone system.

13.2 STANDARDS AND CODES

The Communications System shall be designed and implemented to the latest revision, at the time of award of contract, of the following codes and standards:

- American National Standards Institute (ANSI);
- Electronic Industries Association (EIA);
- Federal Communication Commission (FCC);
- AREMA (American Railway Engineering and Maintenance of Way Association)
- Institute of Electrical and Electronics Engineers (IEEE);
- International Organization for Standardization (ISO);
- Consultative Committee for International Telephone and Telegraph (CCITT);
- National Fire Protection Association (NFPA); and
- Building Industry Consulting Service International (BICSI).

13.3 CONTROL CENTER

The control center shall be composed of two main rooms, the RCC and the Central Control Equipment Room (CCER). Equipment to be located in the RCC includes: control consoles with console-based color-graphics terminals, keyboard and mouse input devices, CCTV system monitors, voice radio equipment, telephone, PA audio communications equipment, and overview display board. CCER equipment includes: data communications equipment, CCS servers and database management systems, an audio playback system to store and access prerecorded PA messages, system manager console equipment, digital access and cross connect system, channel banks, and interconnect equipment.

For future equipment and functionality improvements, it is expected that modern, functional equipment will be installed to enhance or replace the existing systems. Any new Control Center Equipment will be fully compatible with existing systems or those new systems will be installed to replace the previous functionality provided and in revenue service operation.

13.3.1 RCC Layout

The RCC shall be designed to be a comfortable, quiet, and uncluttered working area. To be most effective, the staff positions within the RCC shall be within sight of one another to allow use of visual signals to supplement voice.

The requirements of the overview display shall strongly influence the size and layout of the RCC. The overview display shall be positioned so that the entire track alignment can be viewed comfortably by the LRT Controllers, at their consoles, with a horizontal angular range not exceeding 70 degrees and vertical angular range not exceeding 30 degrees. Each console shall be close enough to the overview display to easily discern the display legends and symbols.

13.3.2 Overview Display

The overview display shall display a dynamic summary of the Metro Transit LRT system, in sufficient detail to allow the Controllers the ability to integrate information regarding train locations, track status, traction power system status, and critical alarm conditions. The following design requirements shall pertain to the overview display:

- Display legends shall be easily read from the Controller consoles. Abbreviations shall be permitted in legends;
- Display colors and flashing indications shall be chosen to draw attention to exceptional conditions;
- Flashing indications shall be used to indicate a discrepancy between a requested condition and sensed condition;
- Overview display intensity and room lighting levels shall be consistent with easy visibility over long periods; and
- Failed overview display equipment shall be replaceable within a 2-hour period and with minimal disruption to operations.

13.3.3 Consoles

Controllers shall utilize consoles to supervise LRT system activities. Each console within the RCC shall contain the communications, reporting, controls, and monitoring equipment necessary to carry out their assigned functions. Consoles of the same type shall be identical and shall be physically divided into three functional areas:

- Operations;
- Communications; and
- Administration.

All consoles shall have the following design requirements:

- Like equipment and procedures shall be used for like functions and like functions shall be in the same general physical location in each console;
- Frequently used equipment shall be located most accessibly. Most-frequently used procedures shall require the fewest, least-extended motions possible;
- The amount of equipment and variety of procedures at a console shall be minimized, consistent with requirements for modular and expandable design;
- Voice communication interfaces shall be integrated such that Controllers need not switch between more than two devices to interact with the several parties with whom they may need to maintain contact. Audio outputs shall have volume and tone controls;
- Console physical dimensions shall be consistent with ergonomic limits;
- Console components shall be modular to allow replacement of a failed unit within 30 minutes, and replacement shall not require shutdown of the functioning portion of the console;
- Writing and documentation storage space shall be provided;
- Terminals shall be low emission, high resolution, and low flicker. Color capabilities shall be consistent with information requirements. Terminals shall be of minimum size consistent with information requirements, density, and viewing distance to minimize emission exposure. Terminals shall have easily accessible intensity and color controls;
- Single purpose function buttons and switches shall be used for, but limited to, functions, which are frequently used or require rapid activation; and
- Keyboard(s) and mouse shall be provided at each console. Choice of other command entry devices shall consider the impact upon RCC staff and of other activities.

13.3.4 Environmental Considerations

The following site requirements shall apply at the control center:

- The RCC shall meet all applicable fire safety requirements, including NFPA 130. A fire alarm and suppression system shall be provided for the RCC and CCER;
- Raised flooring with removable tiles shall be provided for the RCC and CCER. The raised floor framing shall be grounded;
- Wide door access shall be provided at the RCC and CCER to accommodate the movement and placement of equipment;

-
- The RCC shall be fully enclosed to create a secure environment and to minimize noise. The CCER shall also be a secure area;
 - The lighting within the RCC shall be generally uniform, and at a level of at least 50 foot candles, adjustable from 10 to 100 foot-candles. Consoles shall have additional, locally controlled, adjustable task lighting;
 - Reflected glare on terminal screens, overview display, and console work surfaces shall be minimized;
 - Noise within the RCC shall be minimized. There shall be acoustic treatment of the RCC, including ceilings, floors and walls, to absorb noise;
 - The RCC and CCER shall be provided with air conditioning. There shall be independent temperature controls for the RCC and CCER. The temperature in each area shall be adjustable to be within the comfort zone for humans for interior spaces. The air distribution shall minimize temperature gradient and drafts;
 - Electrostatic control shall be provided for in the RCC and CCER. Flooring and carpeting shall not allow static build up. The CCER shall be provided with a ground grid;
 - CCS and human interface equipment within the RCC, including consoles, communications and computers, shall be connected to an Uninterruptible Power Supply (UPS). Other equipment to be connected to the UPS includes all RCC emergency systems; and
 - The communications system equipment shall utilize two independent grounding systems. One grounding system shall be for equipment grounding and the other for electronic signal grounding. The grounding systems shall interface to connection points in the CCER and the RCC.

13.4 CCS/SCADA

13.4.1 Safety Constraints on CCS/SCADA

The CCS/SCADA shall be such that no action or lack of action by the users or any malfunction of the CCS/SCADA equipment can cause an unsafe condition. Should the CCS/SCADA become completely inoperative, for any reason, the Metro Transit LRT System shall continue to operate normally and safely.

13.4.2 System Operation

CCS/SCADA shall normally function without intervention except for routine service of hard copy and external magnetic storage peripherals. CCS/SCADA shall have the capability for performing orderly system start-up and shutdown as commanded by an user.

Remote SCADA equipment shall operate in an unattended mode. The CCS equipment shall continue operation in the event of a failure of station SCADA equipment, and upon return to service of failed equipment, automatically resume normal monitoring and management of that equipment.

13.4.3 Response Times

- The elapsed time from the first possible detection by the SCADA terminal equipment of an alarm or device change of state until display at the RCC shall not exceed 3.0 seconds;
- When a user enters a command for any individual device control, the SCADA terminal equipment shall generate the associated output signal, in the field, in no more than 3.0 seconds; and
- When a user requests a display, the completed display shall appear on the screen in not more than 2.0 seconds.

13.4.4 Accuracy of Information

Display of train position shall be accurate to within a track circuit for signaled territory.

All displayed data shall be consistent as a set. The skew or time difference between measured data points shall be accounted for in the display of those data points so as to preserve their actual timing relationship.

13.4.5 Availability

CCS/SCADA is intended to operate 24 hours a day, seven days a week. The CCS system availability shall be at least 99.8% for all operating functions.

CCS shall be designed such that no single point of failure shall cause any interruption to operation of the CCS with full availability and accessibility of the CCS database and any other database.

Any console shall be capable of fully backing-up a failed console. Back-up shall take the form of assuming the full geographic and functional responsibilities of the failed console.

Backup power shall be provided for all communications equipment installations and sized to carry the load for all communications equipment for a minimum of 8 hours, assuming the lowest allowable environmentally controlled temperature. Provisions for generator power shall be provided including standard plugs and generator transfer switch. When co-located with signal equipment, a combined battery backup design is acceptable when it accomplishes the goals of the signal and the communications equipment reliability design(s).

13.4.6 Displays

Displays at the RCC shall be graphic and text displays. Graphic displays shall be provided at both the overview display and at the console displays. The overview display and console graphics displays shall provide a semi-geographic representation of the Metro Transit LRT System and its major subsystems. Information displayed shall be kept up-to-date, and shall be displayed in the correct logical sequence. For all graphic displays the following guidelines shall be followed:

- Distinct colors and display attributes (e.g., flashing) shall be used to draw attention to alarm or abnormal conditions; and
- There shall be consistent use of colors, geographic orientation, labels, display attributes, and object symbols.

13.4.7 Software

Software design and implementation of CCS/SCADA shall:

- Follow guidelines for software design and documentation as defined in IEEE STD 1016;
- Conduct a software quality assurance program for software development consistent with practices as defined in IEEE STD 730; and
- For safety-critical software, include activities equivalent to those in Task 301 of MIL-STD-882.

The software shall be defined in easily modifiable database elements so that: a) the overview display and console display contents can change as track, stations, and devices are added; and b) console display devices can be changed.

Application software shall be written in an industry-standard high level language. It shall be built on a commercially prevalent or industry-standard operating system and be portable to higher capacity computer system configurations running that standard operating system. Networking system software shall satisfy the Open System Interconnect (OSI) requirements and/or utilize industry-standard physical level and link level communication protocols.

All CCS/SCADA software shall be completely tested before it is used for train operations.

13.4.8 CCS Equipment

The CCS equipment shall:

-
- Utilize commercially available computer equipment and peripheral devices. Custom equipment shall be limited to special functions and interfaces;
 - Normally operate unattended. Consoles and computers shall be capable of automatic re-booting on failures;
 - Have sufficient redundant equipment to permit automatic switchover so that no single failure shall cause any interruption to operation of the CCS, with full availability and accessibility of the CCS database and any other database;
 - Automatically detect equipment failures and provide corresponding failure indications;
 - Where feasible, provide for on-line replacement of failed components, console devices, computers, peripheral devices, and data communications interface equipment while CCS continues to operate;
 - Be sized to handle the defined system configuration under worst case loading conditions and have provision for future expansion by adding subsystem modules.
 - Be physically located and configured in such a way so as to provide for easy maintenance access; and
 - Derive power from an UPS, with a minimum capacity of 60 minutes and an engine generator that shall be provided to furnish power during outage of the normal power source.

13.4.9 Remote Terminals

Remote Terminal Units (RTUs) form the field portion of SCADA and shall:

- Be solid-state, microprocessor based with logic elements and auxiliary components configured on easily replaceable plug-in modules;
- To provide interchangeability of modules, all RTUs shall be of a common design;
- Be capable of continued operations with the loss of communication to RCC as a result of either communication equipment failures or RCC failures;
- Operate normally unattended. Remote SCADA equipment logic and configuration data shall reside in non-volatile memory;
- Perform self-tests upon power up and on command from local test equipment and from RCC. Self-tests shall also be performed by input/output subsystems and input/output cards;
- Provide for maintenance of input/output circuits (including disabling power to output circuits) and safe replacement of input/output cards while power is applied to the remote SCADA equipment;
- Be capable of continued operation between 0°C and +60°C with 0 to 95% humidity (non-condensing);

-
- Operate within a power supply range of plus or minus 5% of its nominal value and a frequency range of 3% of its nominal value;
 - Be capable of continued operation in the electromagnetic environment where they shall be located, such as traction power sub-stations, signal cases, and communications equipment rooms;
 - Support local initialization and troubleshooting with either a local control panel or portable test equipment;
 - Be modular in design to provide expansion of performance and capacity by adding subsystem modules. This shall include the ability to add 20% more input/output subsystem modules;
 - Be supplied with hardware and software tools and documentation for reconfiguration and expansion; and
 - Be capable of internal battery replacement with no loss of memory or rebooting of the affected equipment.

Remote SCADA equipment shall support digital inputs and outputs via relay contact closures (or optically isolated solid state equivalents). All digital inputs to SCADA shall be of the same type. All digital outputs by SCADA shall be of the same type. The following SCADA input and output requirements shall be met:

- Digital inputs to SCADA shall be from Form C relay contacts. The sensing voltage DC power supply shall be in the SCADA domain;
- Input and output signals shall be electrically isolated from SCADA equipment;
- SCADA shall generate outputs via relay contacts. Relays and transient suppression circuits shall be provided by the Communications Contractor. SCADA interface relays and relay contacts shall have an MTBF, at rated loads, of 5,000,000 cycles or more;
- SCADA outputs shall be momentary contact closures with a time duration that is stable and adjustable; and
- The remote SCADA equipment shall prevent unintended action such as energizing output circuits upon power-up and power-restore.

The serial digital data interface may be used between SCADA and processor based devices.

Signals between SCADA and signal rooms shall terminate at one centralized location.

Signals between SCADA and traction power sites shall terminate at one centralized location.

Environmental control system signals between SCADA and a tunnel site shall terminate at one concentrated location.

SCADA terminations shall include test points and rapid disconnect.

Remote SCADA equipment shall be equipped for protection from electromagnetic interference levels consistent with their locations. Bus bars shall be provided for grounding in all termination cabinets.

Remote SCADA equipment shall utilize an Ethernet connection to the CTS for communication with the CCS. The SCADA Ethernet shall be compliant with the latest applicable version of IEEE 802.3. The SCADA Ethernet shall be functionally contiguous among all SCADA remote units and the CCS when linked via the CTS. Error correction and detection schemes shall be used utilizing an industry standard (such as CCITT RCC-16) and, at a minimum shall: 1) detect all errors of up to 16 contiguous bits and 2) detect at least 99% of all error bursts greater than or equal to 16 bits.

13.4.10 Training Simulator

A CCS training simulator shall be provided. The simulator shall allow training of users, CCS validation and testing.

The simulator shall model the physical plant so as to present accurate representations of train movement, interlocking response, and traction power system response for the above purposes. The simulator shall model all discrete state indications which are normally presented to SCADA. The simulator shall be selectively stochastic or deterministic. The simulator shall be capable of simulating normal and abnormal equipment operation.

The user interface to the simulator shall normally be located at the training room console; however, any other console may be configured for training/simulator use with no disruption of system performance. The simulator shall use the standard commands and displays which normally support active operations, supplemented by simulator-specific commands.

The simulator shall model the entire physical plant including the traction power system. The simulator shall be capable of modeling train control or traction power separately or their combination simultaneously.

13.4.11 SCADA Review Station

A workstation capable of providing graphical SCADA information, or a SCADA Review Station, will be placed in the RCC and will allow for the replay of events stored in history for any recorded SCADA point on the same graphical interface as used for system operation. This Workstation will be functionally equipped with a clock indication for time being reviewed, standard playback controls, and the ability to go to a specific time and view specified events.

SCADA system shall be capable of online retrieval of a minimum of thirty (30) days of activity and archive retrieval of all archived activity.

13.5 RADIO SYSTEM

A two-way radio system shall provide voice communication between:

- Metro Transit trains and Controllers;
- Metro Transit trains and LRT Supervisors;
- Metro Transit LRT Supervisors and Controllers;
- Metro Transit non-revenue vehicles and Controllers;
- Metro Transit MOW personnel and Controllers;
- Metro Transit trains and maintenance personnel;
- Metro Transit Controllers and other Metro Transit and emergency response personnel along the ROW;
- Metro Transit trains and emergency response teams; and
- Metro Transit LRT Supervisors and emergency response teams.

All Metro Transit LRV's and transportation and MOW non-revenue vehicles shall be equipped with mobile radio transceivers, with radio frequency output power consistent with the requirements of the Metro Council Regional 800 MHz trunked radio system license. A sufficient number of hand-held portable radios shall be furnished to allow every Metro Transit employee along the LRT right-of-way to carry a portable transceiver.

The radio system shall operate over Metro Council Regional 800 MHz trunked radio system. LRV's shall be equipped with compatible 800 MHz radios. Operational priority equal to that provided to police and fire departments shall be provided for LRT operations for coordination of emergency responses within the tunnel.

In the Airport Tunnel and underground station areas, and in the Minnehaha Tunnel, the radio system shall repeat all channels of the Metro Council Regional 800 MHz trunked radio system. This permits Metro Transit and local emergency personnel (fire, police, and medical) to communicate with their command structure and among themselves in the event of an emergency in the tunnels and/or underground station areas.

In the Airport Tunnel and underground station areas, the VHF and UHF channels used by the Metropolitan Airport Commission (MAC) shall be repeated as well.

13.6 TELEPHONE SYSTEM

13.6.1 PBX Telephone Switch

Digital PBX telephone switches shall be installed at the LRT Operations and Maintenance Facility and at other locations as required. These PBX telephone switches and required telephone sets and interface equipment shall provide communications for employees, and emergency communications at stations and other facilities on the LRT route.

Party lines or other communications schemes that do not offer point-to-point telecommunication from any system node to any other node will not be accepted.

13.6.2 Emergency Telephones

Digital IP capable emergency telephones shall be installed along the alignment on station platforms, in crew offices, control rooms, elevators, and other locations on the LRT system. Each phone shall be equipped with an activation button, a light to indicate "Call Received", volume control, tactile lettering, and Braille equivalents. The activation button and volume control shall meet all applicable ADA requirements.

Digital IP capable blue light emergency telephones shall be installed at tunnel blue light stations, typically in each tunnel bore at each cross passage, and at each traction power substation. Each phone shall be equipped with an activation button, a light to indicate "Call Received", volume control, tactile lettering, and Braille equivalents. The activation button and volume control shall meet all applicable ADA requirements.

Blue light and other Digital IP capable emergency telephones located within the Airport tunnel area shall be routed to the Tunnel Command Post (TCP) whenever the TCP is staffed and directly to the RCC at all other times.

Each emergency telephone shall be equipped with loop supervision to provide a SCADA alarm to the RCC in the event of a data failure or open circuit between the telephone set and its cable termination.

The Communication Console Units at RCC shall have a display window showing a queue of incoming emergency calls along with the status of Controller's response. Actuation of any emergency phone shall cause a visual and audible alarm on the Communications Console Units unless the TCP has been activated. All emergency phone calls shall result in a CCS log record listing time and phone identification.

13.7 CCTV SURVEILLANCE SYSTEM

All Metro Transit stations shall be equipped with color CCTV cameras for remote surveillance from the RCC. Cameras shall be all solid-state, Charge Couple

Device (CCD) units in weatherproof, vandal resistant enclosures. Cameras shall be capable of operating within an ambient temperature range of -20°C to +50°C.

CCTV coverage of the stations shall be primarily confined to station platform areas, with special attention being paid to the fare collection machines. Multi-level stations shall have additional CCTV coverage for elevator cabs and vestibules, and escalators. The station areas shall be monitored using a combination of stationary cameras with fixed lenses as well as cameras equipped to utilize pan, tilt, or zoom features. Security requirements will dictate the need for consistent coverage at the platform edge, TVM machines and Emergency telephones.

Parking lots directly associated with stations shall be covered using color cameras with pan and tilt mountings and zoom lenses. PTZ equipped cameras will allow an authorized user to modify the view, and the system will automatically return to the default “home” view after a prescribed time, according to design.

Tunnel portals, where necessary, shall be covered using stationary color cameras with fixed lenses.

All video images received at the RCC shall be recorded for future playback in a way that is consistent and fully compatible with the existing system as required by the Operator, Metro Transit. CCTV monitoring consoles at the RCC shall allow any camera or any combination of cameras, up to the maximum number of terminals on a single console, to be viewed from any console. Future camera installations must be 100% compatible with the playback and record facilities currently in place at the LRT Maintenance Facility.

In addition to being displayed at the RCC, all Airport tunnel-related camera views shall be transported to the Airport CCTV system, which shall have its own monitors and switching equipment.

Upon execution of the appropriate interagency agreements, CCTV data and functions will be available for use by other agencies according to the terms of that agreement. This might include SPFD, SPPD, MPD, MFD, MnDOT or any other agency that might negotiate access to the Security and supervision system at Metro Transit.

13.8 PUBLIC ADDRESS SYSTEM

All Metro Transit stations shall be equipped with Public Address equipment that is remotely controlled from RCC and locally controlled from the station’s Station Communications Panel (SCP). At the Airport Station, PA announcements can also be made from the Airport Communications Center.

Public address equipment shall consist of amplifiers, automatic volume control circuitry, and loudspeakers. The Public Address system shall be designed in a

redundant manner, so failure of individual components shall not result in complete system failure.

Public Address announcements shall be coordinated with readerboard announcements, providing visual text displays for compliance with ADA requirements.

Provisions for automated announcement and messaging will be required in the design, with separate messages and announcements required for each platform in each direction. The system will determine the route and create an announcement specifically tailored to the direction and operating line for that train i.e.- this system will know a Hiawatha train from a Central train from a Southwest train where they operate on shared tracks.

Each station shall be equipped for local PA and Readerboard access via a SCP, located in a lockbox on the station platform. The SCP also contains a PBX telephone.

13.9 CABLE TRANSMISSION SYSTEM

A fiber-optic Cable Transmission System (CTS) shall be installed along the LRT right-of-way to connect the various field voice, data and CCTV signals between the field and the RCC. CTS shall accommodate both digital and analog signals as follows:

- Each Passenger Station, equipment location and Rail Facility will be required to provide a data stream access point capable of satisfying all data transmission needs, including <patron advisement>, secure DATA for TVM, security and emergency, cameras and SCADA and all other DATA transmission needs listed in this document.
- The CTS network shall be configured to maximize reliability and will feature redundancy in the event of equipment or fiber failure;
- The CTS shall be equipped with rectifier/charger power supplies. All CTS nodes shall include a standard Rail system type battery plant, sized for eight-hour service. The battery plant will provide for all power needs at each facility as designated as vital to continuous and safe system operation, including power for telephone sets and switches, and SCADA, TVM and other systems related to Safety and security.
- The CTS shall be capable of operating within an ambient temperature range of 0°C to +50°C; and
- The CTS and its associated conduit system shall be sized to accommodate future anticipated growth.

13.10 IS (INFORMATION SYSTEM) LAN

Metro Transit's Information System LAN shall be transported to certain locations on the LRT line, to provide employee access at operations rooms and the Tunnel

Command Post. The LAN shall be a minimum of 100 Mbps Ethernet LAN and shall be transported on the CTS. LAN drops at each CTS node shall be functionally contiguous. This equipment will be compatible with existing systems and equipment used in the system.

13.11 TICKET VENDING MACHINE LAN

Metro Transit's Ticket Vending Machine (TVM) LAN sites shall be transported to each station on the LRT line, to interconnect the TVM data network at each station with the TVM server located at the Control Center. The LAN shall be a 10 Mbps Ethernet LAN and shall be transported on the CTS. LAN drops at each CTS node shall be functionally contiguous.

13.12 TWC DATA CIRCUITS

Each Train-to-Wayside Communication (TWC) unit shall be connected with the CCS by means of individual data circuits carried on the CTS or by individual connection to remote SCADA equipment.

Alternately, TWC data circuits may be networked on their own Ethernet LAN and transported on the CTS. LAN drops at each CTS node shall be functionally contiguous.

13.13 TUNNEL COMMAND POST

For any new tunnel, a Tunnel Command Post (TCP) must be provided to meet the requirements of NFPA 130. The TCP shall be provided which takes the form of an Emergency Management Panel (EMP) that shall be installed at an accessible and logical location.

Panels shall be installed in the EMP to provide control of tunnel ventilation systems and overhead catenary power. Fire management information and track occupancy information is presented in the EMP. Also, emergency telephone answering capability, PBX telephones, and inter-agency hotline telephones shall be provided.

Emergency telephone service shall consist of the capability to answer calls from blue light stations within the tunnel area whenever the TCP is staffed. At other times, emergency telephone calls shall be routed to the RCC.

A CTS drop for Metro Transit's management information system LAN shall be provided. Public address and readerboard message origination capability for the tunnel station shall be provided at the TCP.

13.14 LOCATION OF COMMUNICATION EQUIPMENT

CTS nodes and station communications equipment shall be located in communication equipment rooms, which may be in wayside bungalows or a part of other structures. Communication equipment rooms must be climate-controlled to meet equipment operating range requirements and to permit equipment

maintenance. A ventilated communication equipment room shall be provided at the Airport Station.

To the maximum extent possible, all communication equipment shall be located in communication equipment rooms or in environmentally controlled equipment cases.

13.14.1 Clearances

All communications equipment devices and enclosures, including bungalows, cases, radiating cable, antennas, platform and tunnel communication devices, and repeater housings shall clear the LRV dynamic clearance envelope by a minimum of 6 inches. This requirement includes clearance for enclosure doors in any open, intermediate, or closed position.

Equipment housings of all sorts shall be located so as not to obstruct train operators, motorist's, or pedestrian's view of signals and train approaches.

13.14.2 Environmental Considerations

Equipment housings and external devices shall be subject to temperatures ranging from -40°C (ambient) to 60°C (ambient). Housings must be designed to provide an environment suitable for communications equipment operation, taking into account the added effects of sun loading and normal internal heat generation.

The system designer must perform a thermodynamic analysis and provide housings that are properly equipped with auxiliary ventilation, heating and cooling devices so internal equipment is subject to temperatures only within its design limits.

13.15 SECURITY SYSTEMS INTRUSION DETECTION

Intrusion detection for tunnel portals and bridge entrances shall be of the scanning type with sufficient resolution and logic so as to alarm only with intruders and not with trains or small animals. These systems require on-site annunciation consisting of flashing lights and audible warnings.

This system shall provide for a timed bypass via local panel and RCC control for maintenance bypass. Intrusion system shall perform system health checks and provide alarm to the RCC if not functioning.

The intrusion detection system will monitor every door at each signal and communication equipment location including all wayside cases, Sig/Comm houses, TPS as well as sensitive areas such as tunnels and entrances to bridges. The Security system will provide access control for right of way buildings.

13.16 SPECIAL REQUIREMENTS

On all communication systems, all wires and cables shall be labeled using a logically consistent labeling convention matching the convention required by the Metro Transit design engineers. For all communications systems, all conduits, cables, wires, and terminations shall be permanently labeled using a logically consistent labeling convention. Interfaces between the communications and signal systems shall maintain the signal naming conventions to provide for uniform labeling of interconnections or passed logical bits or states between the signal and communications systems.

13.17 LIGHTNING, TRANSIENT PROTECTION, AND GROUNDING

Installations shall be designed and installed to comply with AREMA Section 19 Electrical Protection. Emphasis should be placed on providing primary protection on incoming AC and protection of devices connected to equipment outside of communications enclosures. Lightning damage is a regional issue and all efforts will be made to decrease the susceptibility of the installed to Readerboard and CCTV equipment to the surges, related to lightning or power.

14.0 STRAY CURRENT/CORROSION CONTROL

14.1 PURPOSE

This section describes the design criteria necessary to provide corrosion control measures. Corrosion control measures are required to prevent premature corrosion failures on transit system fixed facilities and other underground structures. Such measures will also minimize stray current levels and their effects on underground and above grade structures. Corrosion control systems should be economical to install, operate, and maintain.

14.1.1 Scope

Corrosion control design criteria encompass all engineering disciplines applied to the project. The criteria are separated into three areas; soil corrosion, stray current corrosion, and atmospheric corrosion. The design criteria for each of these categories, and their implementation, shall meet the following objectives:

- Realize the design life of system facilities by avoiding premature failure caused by corrosion;
- Minimize annual operating and maintenance costs associated with material deterioration;
- Provide continuity of operations by reducing or eliminating corrosion related failures of systems and subsystems; and
- Minimize detrimental effects to facilities belonging to others as may be caused by stray earth currents from transit operations.

14.1.2 System Interfaces

Corrosion control engineering shall be coordinated with the other disciplines, including mechanical, utility, electrical, civil, structural, trackwork, electrification, signalling and communications designs.

14.1.3 Codes and Standards

All design relating to implementation of the corrosion control requirements shall conform to or exceed the requirements of the latest versions of codes and standards identified in these criteria.

14.1.4 Requirements

Soil Corrosion Control. Criteria in this category apply to systems or measures installed to mitigate corrosion caused by soil/rock and groundwater.

Soil/rock samples and ground water samples should be obtained in conjunction with geotechnical testing in areas of extensive below grade construction. The soil/rock samples should be analyzed for resistivity (or

conductivity), moisture content, pH, chloride and sulfate ion concentrations and for the presence of sulfides.

Structures shall be protected against environmental conditions by the use of coatings, insulation, cathodic protection, electrical continuity, or a combination of the preceding, as appropriate.

Stray Current Corrosion Control. Criteria in this category apply to measures installed with the traction power system and trackwork to assure that stray earth traction currents do not exceed maximum acceptable levels. These levels are based on system characteristics and the characteristics of underground structures.

These criteria also apply to measures installed with fixed facilities, and to facilities belonging to others. They are based on anticipated stray earth traction current levels and the characteristics of fixed facilities and other buried structures.

Atmospheric Corrosion Control. Criteria in this category apply to systems or measures installed to mitigate corrosion caused by local climatological conditions and air pollutants.

14.2 SOIL CORROSION CONTROL

This section provides criteria for the design of systems and measures to prevent corrosion of transit system fixed facilities due to contact with area soil/rock and groundwater. Designs shall be based on achieving a minimum 50-year design life for buried structures, with exception of a 100-year design life for the Tunnel and stations, through consideration of the factors given below.

14.2.1 Materials of Construction

All pressure and non-pressure piping and conduit shall be non-metallic, unless metallic materials are required for specific engineering purposes.

Aluminum and aluminum alloys shall not be used in direct burial applications.

If non-native fill is to be used for backfilling concrete or ferrous structures, then it shall meet the following criteria:

- pH 6 to 8;
- Maximum chloride ion concentration of 250 parts per million (ppm); and
- Maximum sulfate ion concentration of 200 ppm.

Use of fill material, which does not meet one or any of the preceding criterion, may be acceptable after review and classification by geotechnical engineers as acceptable for use in the specified application..

14.2.2 Location

Metallic piping and conduits in tunnels shall be routed through vent shafts, inside the structure, and embedded in the invert in lieu of burial. Where this is not practical, buried metallic pressure piping shall include provisions for cathodic protection, and non-pressure piping shall include corrosion control provisions.

14.2.3 Safety and Continuity of Operations

Corrosion control protection shall be required for those facilities where failure of such facilities caused by corrosion may affect the safety, or interrupt the continuity of operations.

14.2.4 Accessibility of Installations

Permanent test facilities installed with certain corrosion control provisions shall be accessible after installation, allowing for periodic maintenance and monitoring.

14.2.5 Special Considerations

Installation of corrosion control measures for facilities owned by others, but designed as part of the transit project, shall be coordinated through the Central Corridor Project Office or its representative. This coordination shall resolve design and construction conflicts to minimize the impact on other system elements.

14.2.6 Materials and Methods

The following paragraphs establish the materials and methods to be used for soil corrosion control.

14.2.6.1 Coatings

Coatings specified for corrosion control of buried metallic or concrete facilities shall satisfy the following criteria:

- Minimum volume resistivity of 109 ohm-centimeters;
- Minimum thickness as recommended for the specific system, but not less than 15 mils;
- A chemical or mechanical bond to the metal or concrete surface. Pressure-sensitive systems are not acceptable; non-bonding systems may be used in special instances, after review by the Corrosion Engineer to be deemed as practical and appropriate;
- Minimum 5-year performance record for the intended service;
- Mill application wherever possible, with field application of a compatible paint or tape system; and

-
- Mechanical characteristics capable of withstanding reasonable abuse during handling and earth pressure after installation for the design life of the system.
 - Generic coating systems include but are not limited to the following:
 - Extruded polyethylene/butyl based system;
 - Coal-tar epoxies (two component systems);
 - Polyethylene-backed butyl mastic tapes (cold applied); and
 - Bituminous mastics (airless spray).

14.2.6.2 Electrical Insulation of Piping

Devices used for electrical insulators for corrosion control shall include nonmetallic inserts, insulating flanges, couplings, unions, and/or concentric support spacers. Devices shall meet the following criteria:

- A minimum resistance of 10 megohms prior to installation;
- Sufficient electrical resistance after insertion into the operating piping system such that no more than 2 percent of a test current applied across the device flows through the insulator, including flow through conductive fluids if present;
- Mechanical and temperature ratings equivalent to the structure in which they are installed;
- Internal coating (except complete non-metallic units) with a polyamide epoxy for a distance on each side of the insulator equal to two times the diameter of the pipe in which they are used. Where conductive fluids with a resistivity of less than 2,000 ohm-centimeters are present, internal coating requirements shall be based on separate evaluation;
- Devices (except non-metallic units) buried in soils shall be encased in a protective coating;
- Devices (except non-metallic units) installed in chambers or otherwise exposed to partial immersion or high humidity shall have a protective coating applied over all components;
- Inaccessible insulating devices, such as buried or elevated insulators, shall be equipped with accessible permanent test facilities; and
- A minimum clearance of 12 in shall be provided between new and existing metallic structures. When conditions do not allow a 12 inch(es) clearance, the design shall include special provisions to prevent electrical contact with existing structure(s).

14.2.6.3 Electrical Continuity of Piping

Electrical continuity shall be provided for all non-welded metallic pipe joints and shall meet the following criteria:

- Use direct burial, insulated, stranded, copper wire with the minimum length necessary to span the joint being bonded.

-
- Wire size shall be based on electrical characteristics of the structure and resulting electrical network to minimize attenuation and allow for cathodic protection.
 - Use a minimum of two wires per joint for redundancy.

14.2.6.4 Cathodic Protection

Cathodic protection shall be accomplished by sacrificial galvanic anodes to minimize corrosion interaction with other underground utilities. Impressed current systems shall be used only when the use of sacrificial systems is not technically and/or economically feasible. Cathodic protection schemes that require connection to the transit system negative return system, in lieu of using a separate isolated anode groundbed, shall not be permitted.

Cathodic protection system design shall be based on theoretical calculations that include the following parameters:

- Estimated percentage of bare surface area (minimum 1 percent);
- Cathodic protection current density (minimum of 1.0 mA/ft² of bare surface area);
- Estimated current output per anode;
- Estimated total number of anodes, size, and spacing;
- Minimum anode life of 25 years (minimum 50 percent efficiency); and
- Estimated anode groundbed resistance.

Impressed current rectifier systems shall be designed using variable voltage and current output rectifiers. Rectifiers shall be rated at a minimum of 50 percent above calculated operating levels to overcome a higher-than-anticipated anode groundbed resistance, lower-than-anticipated coating resistance, or presence of interference mitigation bonds. Other conditions which may result in increased voltage and current requirements shall be considered.

Test facilities consisting of a minimum of two structure connections, one reference electrode connection, conduits and termination boxes shall be designed to permit initial and periodic testing of cathodic protection levels, interference currents, and system components (anodes, insulating devices, and continuity bonds). The designer shall specify the locations and types of test facilities for each cathodic protection system.

14.2.7 Structures and Facilities

The following paragraphs establish the protective measures to be considered for utilities and buried structures.

14.2.7.1 Ferrous Pressure Piping

All new buried cast iron, ductile iron, and steel pressure piping shall be cathodically protected. System design shall satisfy the following minimum criteria:

- Application of a protective coating to the external surface of the pipe (see Section 14.2.6.1);
- Electrical insulation of pipe from interconnecting pipe, other structures and segregation into discrete electrically isolated sections depending upon the total length of piping (see Section 14.2.6.2);
- Electrical continuity through the installation of copper wires across all mechanical pipe joints other than intended insulators (see Section 14.2.6.3);
- Permanent test/access facilities to allow for verification of electrical continuity, electrical effectiveness of insulators and coating, and evaluation of cathodic protection levels, installed at all insulated connections. Additional test/access facilities shall be installed at intermediate locations, either at intervals not greater than 200 feet, or at greater intervals determined on an individual structure basis; and
- Number and location of anodes and size of rectifier (if required) shall be determined on an individual structure basis.

14.2.7.2 Copper Piping

Buried copper pipe shall be electrically isolated from non-buried piping, such as that contained in a station structure, through use of an accessible insulating union installed where the piping enters through a wall or floor. Pipe penetrations through the walls and floors shall be electrically isolated from building structural elements. The insulator should be located inside the structure and not buried.

This buried copper piping shall include provisions for cathodic protection, and any protective, non-pressure piping shall include corrosion control provisions.

14.2.7.3 Gravity Flow Piping (Non-Pressured)

Corrugated steel piping shall be internally and externally coated with a sacrificial metallic coating and a protective organic coating.

Cast or ductile iron piping shall be designed and fabricated to include the following provisions:

- An internal mortar lining with a bituminous coating on ductile iron pipe only (not required for cast iron soil pipe);

-
- A bonded protective coating or unbonded dielectric encasement on the external surfaces in contact with soils (AWWA Standard C105); and
 - A bituminous mastic coating on the external surfaces of pipe 6 inch(es) on each side of a concrete/soil interface.

Reinforced concrete non-pressure piping shall include the following provisions:

- Water/cement ratios meeting the minimum provisions of AWWA;
- Maximum 250 ppm chloride concentration in the total concrete mix (mixing water, cement, admixture and aggregates); and
- Use Type I cement, except as noted in Table 14-1.

14.2.7.4 Electrical Conduits

Buried metallic conduits shall include the following provisions:

- Galvanized steel with PVC or other coating acceptable for direct burial, including couplings and fittings. The PVC coating is not required when conduits are installed in concrete; and
- Electrical continuity through use of standard threaded joints or bond wires installed across non-threaded joints.

14.2.7.5 Hydraulic Elevator Cylinders

Steel hydraulic elevator cylinders shall be designed, fabricated and installed to meet the following criteria:

- External protective coating (see Section 14.3.2.1) resistant to deterioration by petroleum products (hydraulic fluid);
- Outer concentric fiber reinforced plastic (FRP) casing. Casing thickness, diameter and resistivity shall be designed to prevent moisture intrusion (including the bottom) and to maximize electrical insulation between the cylinder and earth;
- Sand fill between the cylinder and FRP casing with a minimum resistivity of 25,000 ohm-centimeters, a pH of between 6 and 8 and a maximum chloride content of 250 ppm;
- Cathodic protection through the use of sacrificial anodes installed in the sand fill;
- Permanent test facilities installed on the cylinder, anodes and earth reference to permit evaluation, activation, and periodic retesting of the protection system; and
- Removable moisture-proof sealing lid installed on the top of the casing prior to installation of the cylinder. The top of the casing shall be permanently sealed against moisture intrusion after installation of the cylinder.

14.2.7.6 Buried Concrete/Reinforced Concrete Structures

The design of cast-in-place concrete structures shall be based on the following provisions.

- Use Type I cement, except as noted in Table 14-1. Use of a concrete mix with a cement type not specifically listed in Table 14-1 must be reviewed by the by the Corrosion Engineer to be deemed as practical and appropriate. ASTM C 452-75 and American Concrete Institute (ACI) Publication SP-77 "Sulfate Resistance of Concrete" should be used as guidelines for evaluating the sulfate resistance of concrete mixes with non-standard cement types;
- Water/cement ratio and air entrainment admixture in accordance with specifications presented in the structural criteria to establish a dense, low permeability concrete. Refer to applicable sections of ACI 201.2R "Guide to Durable Concrete";
- Maximum chloride concentration of 250 ppm in the total mix (mixing water, aggregate, cement, and admixtures). The concrete mix should be such that the water soluble and acid soluble chloride concentrations, at the concrete/ reinforcing steel interface, do not exceed 0.15 and 0.2 percent by weight of cement, respectively, over the life of the structure. Refer to applicable sections of ACI 222R "Corrosion of Metals in Concrete";
- Concrete cover over reinforcing steel shall comply with ACI codes and provide a minimum of 2 inches of cover on the soil/rock side of reinforcement when pouring within a form and a minimum of 3 in of cover when pouring directly against soil/rock; and
- The need for additional measures, as a result of localized special conditions, shall be determined on an individual basis. Additional measures may include application of protective coating to concrete, reinforcing steel, or both.

Precast standardized facilities, such as vaults and manholes, must be reviewed on an individual basis to determine alternative criteria when they cannot be practically modified to meet some or all of the provisions specified herein.

Precast segmented concrete ring construction shall meet the requirements of this Section or be reviewed on an individual basis to determine alternative criteria when they cannot be practically modified to meet some or all of the provisions specified.

14.2.7.7 Support Pilings

The following is applicable only to support piling systems which are to provide permanent support. Pilings used for temporary support do not require corrosion control provisions.

Designs based on the use of metallic supports exposed to the environment, such as H or soldier piles, shall include the use of a barrier coating. The need for special measures, such as cathodic protection, shall be determined on an individual basis, based on type of structure, analysis of soil borings for corrosive characteristics and the degree of anticipated structural deterioration caused by corrosion.

Reinforced concrete piling, including fabrications with prestressed members, shall be designed to meet the following minimum criteria:

- Water/cement ratio and cement types in accordance with Section 14.2.7.6;
- Chloride restrictions for concrete with non-prestressed members shall be in accordance with Section 14.2.7.6;
- Chloride restrictions for concrete with prestressed members shall be in accordance with Section 14.2.7.6, with exception that the concrete mix should be such that the water soluble and acid soluble chloride concentrations, at the concrete/prestressed steel interface, do not exceed 0.06 and 0.08 percent by weight of cement, respectively, over the life of the structure. Refer to ACI 222R "Corrosion of Metals in Concrete";
- A minimum of 3 inches of concrete cover over the outermost reinforcing steel, including prestressing wires, if present; and
- Concrete-filled steel cylinder columns, where the steel is an integral part of the load bearing characteristics of the support structure, shall be designed considering the need for special measures, such as increased cylinder wall thickness, external coating system, and/or cathodic protection. The design shall be determined on an individual basis, based on type of structure, analysis of soil borings for corrosive characteristics and the degree of anticipated structural deterioration caused by corrosion. Chloride restrictions shall be in accordance with Section 14.2.7.6.

14.2.7.8 Reinforced Concrete Retaining Walls

Cast-in-place concrete retaining walls shall be in accordance with the requirements in Section 14.2.7.6.

Modular-type retaining walls shall meet the requirements in Section 14.2.7.6 and the following or be reviewed on an individual basis to determine alternative criteria when they cannot be practically modified to meet some or all of the provisions specified below.

- Embedded and buried steel reinforcing members of the modules should be constructed without special provisions for establishing electrical continuity;
- Steel reinforcing strips of adjacent modules should not be electrically interconnected. The reinforcing strips should be coated with a fluidized bed epoxy resin system or coal tar epoxy system;

-
- Tie-strips should be coated with a fluidized bed epoxy resin system or coal tar epoxy system prior to module construction;
 - The tie-strips should not make electrical contact to the reinforcement steel in each module. A minimum 1 in separation should be maintained; and
 - Longitudinal reinforcing steel within precast concrete parapets and cast-in-place junction slabs should not be made electrically continuous.

14.3 STRAY CURRENT CORROSION CONTROL

This section provides criteria for designs to minimize the corrosive effect of stray earth traction currents from transit operations on transit structures and adjacent structures owned by others.

Stray current control shall reduce or limit the level of stray currents at the source, under normal operating conditions, rather than trying to mitigate the corresponding effects (possibly detrimental) which may otherwise occur on transit facilities and other underground structures. The basic requirements for stray current control are as follows:

- Operate the mainline system with no direct or indirect electrical connections between the positive and negative traction power distribution circuits and ground; and
- Design the traction power system and trackwork to minimize stray earth currents during normal revenue operations.

14.3.1 Traction Power System

Traction power supply system shall be designed as a dedicated system, providing power solely to the light rail line. Joint use of traction power facilities, except for common civil structures, is not permitted. The traction power supply system for the light rail line shall be designed with three electrically isolated, independent subsystems for mainline, yard, and shop.

14.3.1.1 Traction Power Substations (Mainline)

Traction power substations shall be spaced at intervals such that maximum track-to-earth potentials do not exceed 50 volts during normal operations.

The substation shall include a separate dc traction ground mat. The dc traction power ground mat shall be electrically isolated from other grounding facilities in the substation.

Substations shall be provided with access to the dc negative bus for stray current monitoring. Access shall be provided either inside, through use of dedicated wall space if available, or outside through the use of a weathertight

enclosure with an open conduit (minimum 1 inch(es) diameter PVC) between the enclosure and the dc negative bus.

Provisions shall be included to monitor track-to-earth potentials on a continuous basis at traction power substations and at intermediate locations, such as passenger stations.

14.3.1.2 Positive Distribution System

Positive distribution system shall be normally operated as an electrically continuous bus, with no breaks, except during emergency or fault conditions. Intentional electrical segregation of mainline, yard, and shop positive distribution systems is the only type of segregation permitted.

Overhead contact systems (OCS), consisting primarily of support poles, the contact wire and, where applicable, the messenger wire, shall be designed to meet the following minimum requirements and include the following minimum provisions:

- A maximum leakage current to ground of 2.5 milliamperes per mile of single track OCS with 2,500 volts dc applied between the OCS and ground;
- Discrete grounding of individual at-grade support poles, in lieu of interconnecting poles to each other or to a common ground electrode system. Establish electrical continuity of reinforcing steel in OCS support poles as described in Section 14.3.2.3 and electrically connect support poles to the foundation reinforcing steel; and
- Common grounding of support poles on aerial structures through electrical connection to either bonded (welded) reinforcing steel in the deck or to each other and a common ground electrode system, when present. Establish electrical connections as described in Section 14.3.2.3 for OCS poles on aerial structure.

14.3.1.3 Mainline Negative Return System

Running Rails. The mainline and yard track, including special trackwork, and grade crossings shall be designed to have a minimum, uniformly distributed, in-service resistance to earth per 1,000 feet of track (four rails) as determined by the following:

- A computerized simulation shall be used to determine the level of stray current to be permitted and the required track to earth resistances;
- Soil layer resistivity (ASTM G-57) along the entire right of way at a maximum spacing of 500 feet between measurement locations and at depths of 2.5, 5.0, 7.5, 10.0, and 15.0 feet shall be used in the above simulation to determine anticipated earth potential gradients; and

-
- Under no circumstances shall the allowable track to earth resistances be less than:

Direct fixation track:	250 ohms/1000 ft
Embedded track:	100 ohms/1000 ft
Tie & ballast track:	100 ohms/1000 ft

The criteria shall be met through the use of appropriately designed insulating track fastening devices, such as insulated tie plates, insulated rail clips, direct fixation fasteners, rail boots or other approved methods.

Ballasted track construction shall meet the following minimum provisions:

- Use of a hard rock, non-porous, well drained ballast material;
- A minimum 1 inch(es) clearance between the ballast material and all metallic surfaces of the rail and metallic track components in electrical contact with the rail;
- Mainline track shall be electrically insulated from the yard track and the yard track shall be electrically insulated from the shop tracks by use of insulated rail joints in both rails of each track. Location of the insulated joints shall be chosen to reduce the possibility of a car or train bridging the insulator for a time period longer than that required to move into or out of the yard or shop; and
- Mainline track shall be electrically insulated from foreign railroad connections (sidings) by use of insulating rail joints. Location of the insulating joints shall be chosen to reduce the possibility of a vehicle bridging the insulator(s) for a time period larger than required to move onto or off of mainline.

The track slab for embedded track shall employ electrical continuity, electrical isolation, test stations, and electrical sectioning for mitigation and monitoring of stray current activity. The following minimum requirements shall be met:

- Provide electrical continuity of the top layer of reinforcing steel in the track slab by welding all longitudinal lap splices;
- Electrically interconnect all top layer reinforcement steel by welding to transverse collector bars installed at breaks in the longitudinal reinforcing steel, such as at expansion joints, hinges, and at abutments. Install additional transverse collector bars at intermediate locations not to exceed 500 feet;
- Install test stations at each location of longitudinal electrical discontinuity and at intermediate locations, for future electrical continuity and stray current testing. Test station spacing shall not exceed 500 feet. Test stations shall be located outside of the car dynamic envelope to facilitate access and testing;

-
- Provide locations for electrical sectioning of the track slab top layer longitudinal reinforcement to provide a maximum length of electrically continuous reinforcement layer of 1,000 feet. These sectioning locations shall require test stations, as above; and
 - In addition to the primary track isolation arrangement and materials, an insulating material completely surrounding the track slab and terminating at grade level may be considered as a means of achieving allowable track to earth resistance.

Track to earth resistance shall be monitored periodically during construction to detect variations or decrease in resistance. Investigations shall be initiated as soon as a low resistance reading is obtained and the cause of the low reading repaired immediately.

Ancillary Systems. Switch machines, signaling devices, train to wayside communication systems, and other devices or systems attached to the rails shall be electrically isolated from the rails. The criteria shall be met through the use of dielectric materials electrically separating the devices/systems from the rails, such that the criterion given in Section 14.3.1.3 is met.

Electrical Continuity. The running rails shall be constructed as an electrically continuous traction power return circuit through use of either rail joint bonds, impedance bonds, continuously welded rail, or a combination of the three, except for the use of insulated rail joints at the locations noted in Section 14.3.1.3.

14.3.1.4 Maintenance Shop

Shop traction power shall be provided by a separate dedicated dc power supply electrically segregated in both the positive and negative dc power circuits from the yard traction power system and the mainline system as described in Section 14.3.1.3.

Shop track shall be electrically connected to the shop building grounding system.

Other electrically grounded track, such as blowdown pit tracks, and car wash tracks shall be electrically insulated from the yard tracks and powered from the shop traction power supply.

14.3.1.5 Water Drainage

Below grade sections shall be designed to prevent water from dropping or running onto the negative rails and rail appurtenances and shall be designed to prevent the accumulation of freestanding water.

Water drainage systems for sections exposed to the environment shall be designed to prevent water accumulation from contacting the rails and rail appurtenances.

14.3.2 Transit Fixed Facilities

14.3.2.1 Underground Trackway Structures

Reinforcing steel in underground trackway structure inverts shall be made electrically continuous. Minimum requirements for the reinforcing steel from the top of rail down shall include the following:

- Welding of all longitudinal lap splices in the top layer of first pour reinforcing steel;
- Welding of all longitudinal members to a transverse (collector) member at intervals not exceeding 500 feet and at electrical (physical) breaks in the longitudinal reinforcing steel, such as at expansion joints;
- Electrical interconnection of first pour reinforcing steel to second pour reinforcing steel at all collector bars through use of insulated copper cables or steel straps. Longitudinal steel in the second pour shall be made electrically continuous by tack welding all lap splices; and
- Test facilities shall be installed at each end of the structure and at every collector bar. Facilities shall consist of insulated copper wires, conduits, and enclosures terminated at an accessible location.

Precast segmented concrete ring tunnel construction shall meet the requirements in Section 14.2.7.6 and the following or be reviewed on an individual basis to determine alternative criteria when they cannot be practically modified to meet the provisions specified below:

- Embedded steel reinforcing members should be constructed without special provisions for establishing electrical continuity;
- Connecting hardware between adjacent rings and ring segments should be constructed without provisions for establishing electrical continuity between segments;
- Any metallic components which will be exposed to the soils/groundwaters should be coated with a fluidized bed epoxy resin system or coal tar epoxy system; and
- Application of a coal tar epoxy coating system to the external surfaces of each precast panel.

Steel liner tunnel construction must be reviewed on an individual basis to determine the need for special measures, such as increased liner thickness, external coating system, and/or cathodic protection.

14.3.2.2 Aerial Trackway Structures

Column and Bearing Assemblies, Direct Fixation. This section applies to aerial structures and bridges that use a column and bearing assembly that can be electrically insulated from deck or girder reinforcing steel and will have insulated trackwork construction.

- Provide a fusion bonded epoxy coating to all reinforcing steel and provide a wire mesh current collector mat or provide electrical continuity of top layer reinforcing steel in the deck/girder by welding all longitudinal lap splices;
- If the top layer of reinforcing steel is made electrically continuous, electrically interconnect all top layer longitudinal reinforcing steel by welding to transverse collector bars installed at breaks in longitudinal reinforcing steel, such as at expansion joints, hinges, and at abutments. Connect collector bars installed on each side of a break with a minimum of two cables;
- If the top layer of reinforcing steel is made electrically continuous provide additional transverse collector bars at intermediate locations to maintain a maximum spacing of 500 feet between collector bars;
- Provide a ground electrode system at each end of the structure and at intermediate locations to maintain a maximum spacing between ground electrode systems of 1,500 ft. The number, location, and earth resistance of the ground electrode system must be determined on an individual structure basis;
- Provide test facilities at each end of the structure and at intermediate locations to maintain a maximum spacing of 500 feet between test points. The facilities will house test wires from the collector bars and ground electrode system, if present; and
- Provide electrical isolation of reinforcing steel in deck/girders from columns, abutments, and other grounded elements. Isolation can be established through the use of insulating elastomeric bearing pads, dielectric sleeves and washers for anchor bolts and dielectric coatings on selected components.

Column and Bearing Assemblies, Tie and Ballast. This section covers the same type of aerial structures covered above, but with tie and ballast track construction. Welding of reinforcing steel in the deck is not required for this configuration.

- Provide a waterproof, electrically insulating membrane (with protection board on top of the membrane) over the entire surface of the deck that will be in contact with the ballast. The membrane system shall have a minimum volume resistivity of 1×10^{12} ohm-cm.; and
- Provide electrical isolation of reinforcing steel in deck/girders from columns, abutments, and other grounded elements. Isolation can be

established through the use of insulating elastomeric bearing pads, dielectric sleeves and washers for anchor bolts and dielectric coatings on selected components.

Bents and Girders, Direct Fixation. This section applies to aerial structures that use bent type supports with reinforcing steel extending into the deck/girders. Girders can

Provide electrical continuity of top layer reinforcing steel in the deck/girder by welding all longitudinal lap splices.

Electrically interconnect all top layer longitudinal reinforcing steel by welding to transverse collector bars installed at bents and on each side of breaks in longitudinal reinforcing steel, such as at expansion joints, hinges and at abutments (deck side only). Connect collector bars installed on each side of a break with a minimum of two cables.

- Provide electrical continuity of all column/bent steel by welding appropriate reinforcing to at least two vertical column bars. Make these connections to each of the two vertical bars at the top and bottom of the column/bent;
- Electrically interconnect column/bent steel to deck/girder steel by welding at least two vertical column bars to collector bars installed at bents;
- Electrically interconnect column/bent steel to footing steel when column/bent steel penetrates the footing. Weld at least two vertical column/bent bars to footing reinforcing steel;
- Electrically interconnect pre or post tensioned cables to continuous longitudinal reinforcing steel by welding a cable between each anchor plate and the longitudinal reinforcing steel; and
- Provide test facilities at each hinge and expansion joint and at every other column/bent, starting with the first column/bent from an abutment. Test facilities at hinges and expansion joints will house bonding cables from adjacent collector bars on each side of the hinge/joint. Facilities at columns/bents will house two wires from vertical column/bent steel and from the collector bar at the top of the bent.

If electrical continuity of the reinforcing steel is not provided, other methods of stray current control may be employed such as the use of epoxy coated reinforcing steel and stray current collector mats with test facilities.

Bents and Girders, Tie and Ballast. This section covers the same type of aerial structures covered above, but with tie and ballast track construction.

- Provide the same features as described in the bullet points above for direct fixation and the following additional item; and

-
- Provide a waterproof, electrically insulating membrane (with protection board on top of the membrane) over the entire surface of the deck that will be in contact with the ballast. The membrane system shall have a minimum volume resistivity of 1×10^{12} ohm-cm.

Concrete Deck/Exposed Steel, Direct Fixation. This section applies to bridge structures that use a reinforced concrete deck with exposed steel superstructure and will have insulated trackwork construction. This type of construction precludes the electrical insulation of deck reinforcing steel from superstructure steel.

- Provide electrical continuity of top layer reinforcing steel in the deck/girder by welding all longitudinal lap splices;
- Electrically interconnect all top layer longitudinal reinforcing steel by welding to transverse collector bars installed at breaks in longitudinal reinforcing steel, such as at expansion joints, hinges, and abutments. Connect collector bars installed on each side of a break with a minimum of two cables;;
- Provide additional transverse collector bars at intermediate locations to maintain a maximum spacing of 500 feet between collector bars;
- If the total structure length exceeds 250 ft, provide a ground electrode system at each end of the structure and at intermediate locations to maintain a maximum spacing between ground electrode systems of 1,500 ft. The number, location and earth resistance of the ground electrode system must be determined on an individual structure basis;
- Provide test facilities at each end of the structure and at intermediate locations to maintain a maximum spacing of 500 feet between test points. The facilities will house test wires from the collector bars and ground electrode system, if present;
- Provide electrical isolation of reinforcing steel in the deck and superstructure steel from columns, abutments and other grounded elements. Isolation can be established through the use of insulating elastomeric bearing pads, dielectric sleeves and washers for anchor bolts and dielectric coatings on selected components; and
- If electrical isolation of reinforcing steel in the deck and superstructure steel from columns, abutments and other grounded elements cannot be obtained, then electrical continuity of metallic components within these later elements must be established by appropriate welding and bonding procedures.

If electrical continuity of the reinforcing steel is not provided, other methods of stray current control may be employed such as the use of epoxy coated reinforcing steel and stray current collector mats with test facilities.

Concrete Deck/Exposed Steel, Tie and Ballast. This section covers the same type of aerial structures covered above, but with tie and ballast track construction. Welding of reinforcing steel in the deck is not required for this configuration.

- Provide a waterproof, electrically insulating membrane (with protection board on top of the membrane) over the entire surface of the deck that will be in contact with the ballast. The membrane system shall have a minimum volume resistivity of 1×10^{12} ohm-cm;
- Provide electrical isolation of reinforcing steel in the deck and superstructure steel from columns, abutments and other grounded elements. Isolation can be established through the use of insulating elastomeric bearing pads, dielectric sleeves and washers for anchor bolts and dielectric coatings on selected components; and
- If electrical isolation of reinforcing steel in the deck and superstructure steel from columns, abutments, and other grounded elements cannot be obtained, then electrical continuity of metallic components within these latter elements must be established by appropriate welding and bonding procedures.

Retaining Walls. All longitudinal bars overlaps in both faces of the wall, including the top and bottom bars in the footing, shall be tackwelded to insure electrical continuity. Longitudinal bars in the footing shall be made electrically continuous to the longitudinal bars of the walls. Collectors bars, bonding cables and test facilities shall be installed as stated in 14.3.2.1.

14.3.2.3 Overhead Contact System (OCS) Pole Foundation Grounding

All metallic components, inclusive of the pole baseplate, that will be partially embedded or come in contact with concrete surfaces shall be coated with a sacrificial or barrier coating. The sacrificial coating shall be applied to the entire component. The barrier coating shall extend a minimum of 6 in into the concrete and a minimum of 1/2 inch(es) above the surface of the concrete.

At-Grade OCS Support Poles

Electrical continuity of reinforcing steel within support pole foundations shall be established to provide an adequate means for dissipating any leakage current from the contact wire and, where applicable, the messenger wire. The following minimum provisions shall be included with design:

- The outermost layer of vertical reinforcing steel within the concrete foundation shall be tack welded at all intermediate vertical lap joints and to reinforcing bar collector rings (two) installed at the top and bottom of the reinforcing bar cage;
- A copper cable shall be connected between the base of the catenary support pole and the foundation reinforcing steel. The cable shall be

Exothermic welded or brazed to the support pole and routed in such a manner that it will not be susceptible to damage during construction or after installation is complete. The connection to the pole shall be coated with a zinc-rich weather resistant coating material;

- The copper cable shall be sized based upon anticipated fault current and fault clearing time; and
- Different electrical continuity requirements, may be necessary depending on the actual reinforcing configuration for the support pole foundations.

OCS Poles on Aerial Structures. OCS poles located on aerial structures shall include either of the following minimum set of provisions, depending on the type of aerial structure.

- Where the aerial structure includes welded deck reinforcing steel connected to a ground electrode system, electrically interconnect the OCS support poles on the structure and connect these poles to the ground electrode system. Connection to the pole shall be as above;
- Cabling used to interconnect the poles and the ground electrode system shall be sized based upon anticipated fault current and fault clearing time;
- The cabling shall be routed in conduit and terminated in junction boxes or test cabinets that also house wires from the deck reinforcing steel and the ground electrode system;
- Cabling shall be designed to allow for connection of interconnected OCS poles along the aerial structure to all ground electrode systems installed with a particular aerial structure;
- Where the aerial structure has welded deck reinforcing steel but does not include a ground electrode system, electrically connect the OCS support poles to the welded deck reinforcing steel. Connection to the poles shall be as above;
- Provide a copper cable from each OCS support pole to the deck reinforcing steel. The copper cable shall be sized based upon anticipated fault current and fault clearing time;
- Exothermic weld or braze the cable to the OCS support pole and preferably to the nearest transverse collector bar installed in the aerial structure deck; and
- Where it is not practical to connect an OCS pole directly to a transverse collector bar, because of excessive distance or other factors, connect the pole to a local transverse reinforcing bar using a copper cable and weld the transverse reinforcing bar to at least three upper layer longitudinal reinforcing bars in the deck.

14.3.2.4 Utility Structures

All piping and conduit shall be non-metallic, unless metallic facilities are required for specific engineering purposes. There are no special provisions required if nonmetallic materials are used.

Metallic Facilities (Systemwide)

- Pressure or non-pressure piping exposed within tunnels or crawl spaces or embedded in concrete inverts shall not require special provisions;
- Pressure piping that penetrates tunnel, foundation, or station walls shall be electrically insulated from the external piping to which it connects and from watertight wall sleeves. Electrical insulation of interior piping from external piping shall be made on the inside of the tunnel or station; and
- All buried pressurized piping external to tunnels, crawl spaces, and station structures shall meet the criteria specified in Section 14.3.3.

14.3.3 Facilities Owned by Others

14.3.3.1 Replacement/Relocated Facilities

Corrosion control requirements for buried utilities installed by the owner/operator as part of transit construction shall be the responsibility of the individual utility owner/operator. Minimum stray current corrosion control criteria, when guidance is requested by the utility owner/operator, shall be in accordance with Section 14.3.3.2.

Relocated or replaced utilities, installed by transit contractors as part of contractual agreement between the transit agency and the utility, shall be installed in accordance with the utility owner specifications and shall include the following minimum provisions. These provisions are applicable to ferrous and reinforced concrete pressure piping. Other materials and structures will require individual review.

- Electrical continuity through the installation of insulated copper wires across all mechanical joints for which electrical continuity cannot be assured (see Section 14.2.7.3);
- Electrical access to the utility structure via test facilities installed in accordance with Section 14.2.7.1; and
- The need for additional measures, such as electrical isolation, application of a protective coating system, installation of cathodic protection, or any combination of the preceding, shall be based on the characteristics of the specific structure and to not adversely effect the existing performance within the environment.

14.3.3.2 Existing Utility Structures

The need for stray current monitoring facilities shall be jointly determined by Mn/DOT and the utility operators. If utilities require assistance, the following minimum provisions shall be suggested.

Test facilities may be installed at select locations for the purpose of evaluating stray earth current effects during start-up and revenue operations. Guidelines for location of test facilities shall be as follows:

- At all utility crossings with the system, and on structures that are within 300 feet and parallel to the system right-of-way; and
- At locations on specific utility structures that are within 300 feet of the system traction power substations.

14.3.3.3 Existing Bridge Structures

Stray current corrosion control for existing bridge structures shall be addressed by limiting earth current levels at the source (running rails). Meeting the criteria established in Sections 14.3.1.1, 14.3.1.2, 14.3.1.3, and 14.3.2.2 will provide the primary stray current control for these facilities.

14.4 CORROSION CONTROL COATINGS

Coatings shall have established performance records for the intended service and be compatible with the base metal to which they are applied.

Coatings shall be able to demonstrate satisfactory gloss retention, color retention, and resistance to chalking over their minimum life expectancies.

Coatings shall have minimum life expectancies, defined as the time prior to major maintenance or reapplication, of 15 to 20 years.

14.4.1 Metallic-Sacrificial Coatings

Acceptable coatings for carbon and alloy steels for use in tunnels, crawlspaces, vaults, or above grade are as follows:

- Zinc (hot-dip galvanizing [2 oz per sq ft] or flame sprayed);
- Aluminum (hot-dip galvanizing [2 mil thickness] or flame sprayed);
- Aluminum-zinc; and
- Inorganic zinc (as a primer).

14.4.2 Organic Coatings

Organic coating systems shall consist of a wash primer (for galvanized and aluminum substrates only), a primer, intermediate coat(s), and a finish coat. Acceptable organic coatings, for exposure to the atmosphere, are as follows:

-
- Aliphatic polyurethanes;
 - Vinyl copolymers;
 - Fusion-bonded epoxy polyesters, polyethylenes, and nylons;
 - Acrylics, where not exposed to direct sunlight;
 - Alkyds, where not exposed to direct sunlight; and
 - Epoxy as a primer where exposed to the atmosphere or as the complete system where sheltered from sunlight.

14.4.3 Conversion Coatings

Conversion coatings, such as phosphate and chromate coatings, shall be used as pretreatments only for further application of organic coatings.

14.4.4 Ceramic-Metallic Coatings (Cermets)

This hybrid-type coating system is acceptable for use on metal panels and fastening hardware.

14.4.5 Sealants

Seal all crevices with a polysulphide, polyurethane or silicone sealant.

14.4.6 Barrier Coating System

Use one of the following barrier coating systems where corrosion protection is needed but appearance is not a primary concern:

- Near white blast surface according to SSPC-SP 10. Follow with a three coat epoxy system;
- Commercial blast surface according to SSPC-SP 6. Follow with a two coat inorganic zinc and high build epoxy system;
- Near white blast surface according to SSPC-SP 10. Follow with a three coat epoxy zinc, high build epoxy system; and
- Apply all coatings according to manufacturer's specifications.

Use one of the following barrier coating systems where corrosion protection and good appearance are needed.

- Near white blast surface according to SSPC-SP 10. Follow with a three coat inorganic zinc, high build epoxy, polyester urethane system;
- Near white blast surface according to SSPC-SP 10. Follow with a three coat vinyl system;
- Commercial blast surface according to SSPC-SP 6. Follow with a three coat epoxy zinc, high build epoxy and polyester urethane system;
- Commercial blast surface according to SSPC-SP 6. Follow with a three coat epoxy zinc, high build epoxy and acrylic urethane system; and
- Apply all coating according to manufacturer's specifications.

14.5 GROUNDING COORDINATION

Coordination shall be undertaken to insure that grounding design and corrosion control measures do not conflict so as to render either system ineffective.

TABLE 14-1
ACCEPTABLE CEMENT-TYPE BASED ON SULFATE CONCENTRATIONS
OF SOILS AND GROUNDWATERS

Acceptable Cement Type	Percent Water Soluble Sulfate (as SO ₄) in Soil Samples (%)	ppm Sulfate (as SO ₄) in Groundwater (ppm)
Type I	0 to 0.10	0 to 150
Type II	0.10 to 0.20	150 to 1,000
Type V	Over 0.20	Over 1,000

15.0 FARE COLLECTION SYSTEM

15.1 GENERAL

It is anticipated the design for the fare collection system will consist of three major subsystems: Ticket Vending Machines (TVMs), Stand-Alone Ticket Validators (SATVs), and a Centralized Data Collection and Information System (CDCIS). The TVMs will communicate with the CDCIS via the fiber optic communications network being designed by the station designer. In addition, it is anticipated that the fare collection system shall utilize the SCADA system to indicate maintenance needs and security alarms.

15.2 INFRASTRUCTURE NEEDS

The LRT Systems design shall provide physical, electrical, and communications infrastructure to meet the needs of the fare collection system. Metro Transit will provide Fare Collection Equipment foot prints along with necessary conduits and anchorage details to assure a coordinated design.

15.2.1 Physical Infrastructure

The Designer shall anticipate station platforms made of concrete or other approved materials of sufficient strength and thickness to securely anchor and support the fare collection equipment. Where TVMs and SATVs are to be installed on grade-level platforms, the concrete shall be no less than 8 inches thick to provide for ample depth of anchor bolts (to be installed by the Fare Collection Contractor). The design of elevated platforms shall allow for the necessary anchor bolts to be installed in the field in such manner to securely anchor the fare collection equipment.

15.2.2 Electrical Infrastructure

15.2.2.1 Conduits

The Designer shall also design and install all conduits needed by the fare collection system. The conduits shall be dedicated to the fare collection system; no other wires shall be assigned to or installed in these conduits by the Designer. For each TVM location identified (initial and future), separate power and data communications conduits shall be installed. These conduits shall be as per NEC, with a 1 inch minimum for exterior systems and ¾ inch for interior.

Power conduits shall terminate at the power distribution point for the station. Data communications conduits shall terminate in each station's communications enclosure.

Final routing of all fare collection conduits shall be subject to approval by the agency.

15.2.2.2 Junction Boxes

Power and data conduits for each TVM shall terminate at the TVM location in water-tight junction boxes. The junction boxes shall be 6 to 8 inches square and 6 to 8 inches deep, and shall be suitable for embedded installation in public concrete walkways. Power and data conduits for SATVs shall be stubbed flush with the platform finished surface and plugged; these conduit stubs shall be no more than 2 inches apart.

15.2.2.3 Power Requirements

All fare collection equipment at the stations will operate at 120 VAC. The Contract installer shall supply and install 20-amp circuit breakers for each TVM in the electrical panel at which the fare collection power conduits terminate. Each circuit breaker designated for fare collection use shall be clearly marked on the electrical panel schematic. No additional power circuits will be required for SATVs.

15.2.2.4 Wiring

Installation, termination, and connection of all power wiring between the circuit breaker panel and the fare collection equipment shall be the responsibility of the Fare Collection Contractor. Similarly, installation, termination, and connection of all data communications wiring between the communications enclosure and the fare collection equipment shall be the responsibility of the Fare Collection Contractor. The Fare Collection Contractor will also make all necessary connections of power and data wiring within the fare collection equipment.

15.2.3 Communications Infrastructure

All TVMs will communicate with a Fare Collection Network Controller (FCNC) central computer system via the fiber optic communications system; this computer is the core of the CDCIS. The Designer shall provide a communications system that supports the needs of the fare collection system.

15.2.3.1 Communications Interfaces

The fare collection system will employ standard communications interfaces and protocols between the station equipment and the central computer system. The Designer shall provide each station with an Ethernet communications port providing no less than 10/100 megabits per second (mpbs) throughput. The Ethernet port shall be supplied with an RJ-45 jack suitable for use in 10/100-base-T applications. The Fare Collection Contractor will be responsible for supplying any hubs and routers necessary to connect the station equipment to the Ethernet port.

15.2.3.2 SCADA Interface

All fare collection equipment at each station will be monitored by SCADA. Two distinct SCADA inputs at each station shall be allocated by the Designer for the fare collection system.

15.2.3.3 Communications Enclosure

Within each station's communications enclosure, the Designer will provide space within the rack equipment for the data networking equipment to be supplied by the Fare Collection Contractor. At least 18 inches of vertical rack space shall be allocated to the fare collection equipment inside each station's communications enclosure.

The communications enclosure shall also include a single 15-amp 120 VAC circuit for fare collection data communications equipment.

In addition, the communications enclosure shall provide terminal blocks with lightning protection for the incoming fare collection data wiring. Protected terminal blocks shall be provided for at least six 10/100 base-T Ethernet connections. The Designer shall provide an RJ-45 jack for each of the protected Ethernet lines. These jacks shall be installed adjacent to the rack location designated for the fare collection equipment in the communications enclosure.

Protected terminal blocks shall also be provided and clearly labeled for the two incoming SCADA lines designated for fare collection. The Designer shall connect these protected terminals to the appropriate points on each communication enclosure's SCADA panel.

15.2.3.4 Central Control Communications

At the central control facility where the FCNC (Fare Collection Network Controller) computer will reside, the Designer shall provide the necessary data communications interfaces to connect the Ethernet connections from the stations to the FCNC. The Fare Collection Contractor will be responsible for supplying any hubs and routers necessary to connect the station Ethernet ports to the FCNC.

The Designer shall install and designate two 24-inch equipment racks in the central control facility for the fare collection computer system and communications equipment. These racks shall be supplied with four 15-amp 120 VAC circuits. These circuits shall be battery-supported by the central control facility's uninterruptible power supply.

Appropriate indications for each station's two SCADA inputs shall be provided by the Designer to be consistent with other LRT system status alarms.

15.2.3.5 Fare Collection System Remote Workstations

It is anticipated that maintenance and administration of the fare collection system will require the agency to use remote computer workstations at an equipment maintenance facility (location unknown) and at the agency's headquarters. The Designer shall provide a communications system able to support 10/100 mbps Ethernet/TCP-IP communications between the FCNC and these locations over the fiber optic network or other suitable means.

15.3 SCHEDULE SUPPORT

The Fare Collection Contractor will require access to at least one finished station no less than three months prior to the start of revenue service to conduct a Pilot Station Test. In addition to a finished station, this test will also require a working data communications system between that station and the central control facility. The Designer shall identify the station at which the Fare Collection Pilot Station test is to be conducted no less than 6 months prior to the start of revenue service. The Designer shall also provide all necessary infrastructure at that station and the central control facility to support this test.

All other stations shall be finished and ready for installation of fare collection equipment no less than six weeks prior to the start of revenue service. All stations shall have working data communications and SCADA to support post-installation testing and security monitoring of the fare collection equipment at the time of fare collection equipment installation.

The Designer shall work with the station electrical/installation contractor to coordinate installation and testing schedules with the Fare Collection Contractor.

16.0 CIVIL ENGINEERING

16.1 GENERAL

These performance and design criteria establish minimum standards to be used in the design of civil engineering elements of the Central Corridor Light Rail Transit (CCLRT) System.

16.2 CONTROL SURVEY

16.2.1 Horizontal Control

The Horizontal Control for all elements and facilities shall be referenced to the survey baseline control points established for this project. The coordinates for control points, mapping, and construction stakeout will be based on the NAD 83-96 ADJ Hennepin County coordinate system in English Units. All supplemental surveys are to be conducted in accordance with 3rd order standards as specified by Mn/DOT Surveying & Mapping Manual (2-4.05 Supplemental Horizontal Control Surveys).

16.2.2 Vertical Control

The Vertical Control for all elements and facilities shall be referenced to MN/DOT 2nd order vertical control points, North American Vertical Datum 1988 (NAVD 88) in English Units. All supplemental surveys are to be conducted in accordance with 3rd order standards as specified by MN/DOT Surveying and Mapping Manual (2-5.05 Supplemental Vertical Control Surveys).

16.3 CLEARANCES

16.3.1 General

The criteria developed in this section apply to the design of the entire system. All designs shall provide not less than the minimum clearances as specified in this Section.

Assurance of adequate and appropriate clearance for the passage of light rail vehicles throughout the mainline trackage, switches and special trackwork, stations, storage yards and operations facilities is one of the most fundamental concerns inherent in the design process and must be rigorously monitored during the final design and construction phases. Design criteria for clearances are complex and are based on numerous assumptions and interfaces.

It is in the development of clearance requirements that the build-up of concurrent, multiple tolerances must be scrutinized and balanced with the practicality of available space and other functional requirements. The clearance requirements in this Section seek to make that balance.

16.3.2 Clearance Envelope

The clearance envelope (CE) is defined as the space occupied by the vehicle dynamic envelope (VDE) plus the effects of other wayside factors (OWF) including construction, fabrication, and maintenance tolerances for certain track and facilities plus running clearances (RC). Simplistically this relationship can be expressed as follows:

- $CE = VDE + OWF + RC.$

Generally speaking, the clearance envelope represents the space in or into which, other than the light rail vehicle, no physical part of the system may be placed or constructed or may protrude. The clearance envelope is normally referenced from, or represented by its relationship to, the theoretical centerline of track at top of rail (TOR), including the effects of superelevation.

For horizontal curves with spirals, the tangent clearance envelope shall end 50' before the point of tangent-to-spiral (TS) and 50' after the point of spiral-to-tangent (ST). The full curvature clearance envelope shall begin 25' prior to the point of spiral-to-curve (SC) and end 25' beyond the point of curve-to-spiral (CS). The horizontal component of the vehicle dynamic envelope between these two offset points (i.e., 50' before TS and 25' before SC) shall be considered to vary linearly with the distance between the two points. Horizontal offsets at intermediate locations shall be calculated with straight line interpolation. For horizontal curves that do not include spiral transition curves, the full curvature clearance envelope shall begin 50' prior to the point of curvature (PC) and extend to 50' beyond the point of tangency (PT). More detailed computer analysis with more precise geometry may be used, subject to Metro Transit approval, to define the clearance envelope in place of these 25' and 50' locations and straight line interpolations.

The clearance envelope through turnouts shall be calculated based on the turnout centerline radius.

16.3.2.1 Vehicle Dynamic Envelope

In addition to the car static dimensions, the VDE includes all possible vehicle movements, vehicle tolerances, and certain closely-related rail/track tolerances. More specifically, the VDE is based upon the following certain criteria:

- Static geometry of the vehicle;
- Roll angle of $\pm 4^\circ$;
- Suspension lateral travel (per side) of 1.340";
- Wheel gauge construction tolerance (per side) of 0.031";
- Lateral wheel wear (per side) of 0.300";
- Radial wheel wear of 1.000";

-
- Rail gauge construction tolerance (per side) of 0.125”;
 - Lateral rail wear (per side) of 0.500”;
 - Wheel-to-rail sideplay (per side) of 0.375”.

Appendix A provides further explanation of these certain criteria plus the calculated VDE dimensions in tabular form for 28 representative locations on the light rail vehicle cross-section as a function of radius of curve (82’ to tangent), amount of superelevation (0” to 6”), and amount of cross level track variation (0.5” or 1.0”). For intermediate curve radii (e.g. 275’) or intermediate superelevation values (e.g. 3.5”) not listed in these tables, straight line interpolation between adjacent values shall be used.

It is critical that these VDE tables be used correctly in development of the clearance envelope for any given condition.

Figure 8-3 in Chapter 8 provides a simplified outline of the dynamic envelope of the light rail vehicle. However, this outline is based on nominal track conditions and does not include the effects of other OWF. Figure 8-3 is for carbuilder use only and shall not be used to calculate the CE.

16.3.2.2 Other Wayside Factors

The clearance envelope can be determined by adding other wayside factors (OWF) for certain construction and maintenance tolerances plus running clearance to the vehicle dynamic envelope. Other wayside factors is the sum of certain construction tolerances (CT) plus certain maintenance tolerances (MT) plus a chorded wall construction factor (CW) to account for the effects of certain wall construction, all where applicable.

$$\text{OWF} = \text{CT} + \text{MT} + \text{CW}$$

The following define the other wayside factors and are applicable to and included in the horizontal component of the CE.

CT = Construction tolerances (allowable deviation from design position) track = 0.5” open, paved, and direct fixation plus:

- poles or signals equipment = 1.0”;
- walls = 1.0”;
- tunnel lining = 3.0”;
- tunnel walkway = 0.5”.

MT = Maintenance tolerances (allowable deviation from design condition):

- track = 2.0” open track; or
- track = 0.5” paved and Direct Fixation track.

CW = Additional width for chorded construction of walls to be added only for outside of curves. (See Figure 16-1 and 16-2).

16.3.2.3 Running Clearances

In addition to the vehicle dynamic envelope and the other wayside factors, the clearance envelope includes an allowance for running clearances (RC). Running clearances can be considered as a clearance contingency after the inclusion of all factors purporting to define the vehicle, the vehicle tolerances, the ROW construction tolerances, and the ROW maintenance tolerances. Running clearances are specific to the ROW conditions encountered and shall include one of the following in any direction:

- 2" for traction power poles, conduit, signals, signs, and other non-structural members; or
- 2" for tunnel walkway edge; or
- 3" for pantograph electrical clearance; or
- 6" for structural members; or
- 0" for adjacent LRVs.

A clearance contingency for passing LRVs is not considered necessary.

16.3.3 Special Clearance Situations

In addition to the more routine clearance envelope determinations above, there are several special clearance situations warranting further attention and definition. These special situations include undercar clearances, pantograph clearances in tunnel sections, vehicle interface at station platforms and at safety/maintenance walkways in tunnel sections, and general walkway areas along the ROW where applicable.

16.3.3.1 Undercar Clearances

As discussed in Section 8.5.4, vertical undercar clearance is defined from TOR with the maximum suspension deflection and car body roll, minimum vertical curve radius, and fully worn wheels. The minimum vertical clearance envelope shall be 2" except in paved track areas between the rails where a crown for drainage may extend not more than 0.75" above TOR, thus reducing the vertical clearance at worst case to 1.25".

The horizontal component of the 2" vertical clearance envelope shall be defined by VDE Table in Appendix A.

16.3.3.2 Pantograph Clearances in Tunnels

Special attention must be paid to determination of appropriate pantograph clearances in tunnels due to the constrained, rounded upper corners of typical tunnel cross sections.

Appendix B provides a detailed list of assumptions and requirements relative to these proper pantograph clearances. For clearance purposes, the wire height and modified clearance points (i.e., P4in, P5in, P4out, and P5out) which incorporate a 4" passing electrical clearance (RC) from Appendix B shall be used for defining the pantograph clearance envelope in tunnels.

16.3.3.3 Station Platform Interface

The relationship of the vehicle at rest and the station platform is one of the most fundamental interfaces in any rail transit system. Horizontal and vertical static clearances or gaps (between platform edge and vehicle step) determine the ease of boarding/alighting for passengers, and platform edges often must be placed within the strict confines of clearance envelopes so as to permit safe and practical passenger movement.

The station platform interface shall be as described in Chapter 6. Platform edge shall be located 53.5" from track centerline on tangent track. Top of platform shall be 14.0" above the plane of top of rails. Tolerances shall satisfy ADA requirements.

16.3.3.4 Walkway in Tunnels

An emergency/maintenance walkway shall be provided in each tunnel bore.

16.3.3.5 Walkway Area Other Than in Tunnel

In addition to the clearance envelope requirements per Section 16.3.2, it is desirable that space be provided for maintenance walkways adjacent to the trackway. The walkway envelope shall extend at least 2'-6" from the edge of the clearance envelope and shall extend to 6'-6" above the walkway. Unless otherwise approved by Metro Transit, walkways shall be provided either on both sides of the trackway or in the median between tracks, and shall permit unobstructed passage to a ground-level location from which passengers can be evacuated. For walkway clearance calculations only, traction power poles shall not be considered a permanent obstruction.

This requirement is not applicable to embedded track sections.

16.3.3.6 Track Centers With Center Poles

For open track with center traction power poles, the track centers shall be calculated based on the appropriate clearance envelopes, a design width for the traction power poles of 12", and lateral deflection due to loading of 0.75" below 12' from TOR and 1.0" above 12' from TOR.

16.4 STREET DESIGN

16.4.1 General

Unless otherwise specified, all road and street design shall be in accordance with the current specifications and design guidelines of the involved local jurisdictions. For those cases where the local jurisdictions have no design guidelines, Minnesota Road Design and State Aid Manuals shall be used.

16.4.2 Horizontal Geometry

Horizontal alignment of public streets shall conform to the current specifications and standards of the involved local jurisdictions. In a case where the local jurisdictions have no codes or standards, Minnesota Road Design and State Aid Standards shall be used.

16.4.3 Vertical Geometry

Vertical geometry of public streets shall conform to the current specifications and standards of the involved local jurisdictions. In a case where the local jurisdictions have no codes or standards, Minnesota Road Design and State Aid Standards shall be used.

16.4.4 Superelevation and Cross Slope

The roadway cross section of public streets shall conform to the current specifications and standards of the involved local jurisdictions. In a case where the local jurisdictions have no codes or standards, Minnesota Road Design and State Aid Standards shall be used.

16.4.5 Clearance to LRT Facilities

The design of public streets adjacent to LRT facilities shall accommodate the construction of LRT stations as discussed in Chapter 6 and the operation of light rail vehicles as detailed in Sections 16.3 and 8.5.

16.4.6 Signs, Bollards, and Markers

Where ROW permits, signs, bollards and markers shall conform to the clearance requirements listed in 16.3.2.2. Breakaway units shall be used where the installation is in a location exposed to street traffic, except where the purpose is protection of passengers (e.g., at platform ends).

16.4.7 Paving

16.4.7.1 Codes and Standards

Pavement in public streets shall be in conformance with the current specifications and practices of the involved local jurisdictions or by Mn/DOT.

16.4.7.2 Restored Pavement

Restored pavements shall conform to widths prevailing prior to LRT construction. No street, sidewalk, or alley widening shall be included, unless required by new construction, or by agreement with the local jurisdiction involved.

16.4.7.3 Castings

In areas where the roadway must be reconstructed due to LRT requirements, castings shall be replaced with new. Existing castings shall be salvaged if possible and turned over to the applicable agency.

16.4.8 Signs and Striping

Signs and striping in public streets shall be in conformance with the current specifications and practices of the involved local jurisdictions. In a case where the local jurisdictions have no codes or standards, the Minnesota Manual on Uniform Traffic Control Devices shall be followed.

16.4.9 Ramps and Curb Cuts

The Designer shall obtain from the local jurisdiction the locations of curb cuts.

The design of curb cuts and pedestrian curb ramps for the handicapped shall be in accordance with the applicable provisions of the U.S. Department of Transportation's (USDOT) Transportation for Individuals with Disabilities: Final Rule and Mn/DOT design manuals and standard plates. Material standards shall follow applicable agency requirements such as tactile strips, markings, and other local requirements promulgated in accordance with USDOT requirements.

Curb cuts are to be included when curbs in public space are constructed or restored as part of the Project.

16.4.10 Curbs

Curbs, other than those used for station platforms, shall meet the clearance conditions specified in Section 16.3 and shall be no less than 6'-0" from the track centerline as measured to the curb face. Clearances of less than 6'-0" may be permitted with Metro Transit approval.

16.4.11 Fencing

Access to the light rail tracks shall be controlled by fencing where appropriate to provide security and/or enhance safety. Fencing shall generally be parallel to the track, forming an open-ended envelope and allowing unrestricted LRV

movement. Centerline fencing (between the two tracks) is desired but not required where light rail vehicles operate in City streets to encourage pedestrians to cross at formal crossing locations.

Vehicle service, maintenance and storage areas shall be secured by perimeter fencing.

Type, size and location of fencing or barriers shall be determined by site-specific conditions/requirements.

16.4.12 Guardrail and Barrier Wall

Follow AASHTO and Mn/DOT/local agency guidelines for installation of guardrail or barrier walls to mitigate “clear zone” infringements.

16.4.13 Existing Street Lighting

Existing street luminaries which will be impacted as a result of LRT construction shall be salvaged and replaced wherever possible. Where road or other geometric changes require significant relocation of luminaires, impacted luminaries shall be replaced to ensure sufficient lighting levels as identified in Section 11.5.3, or as required by the applicable agency.

16.5 DRAINAGE

16.5.1 General

Drainage design shall be in accordance with the standards and practices of the agency in whose jurisdiction each project or section of a project falls. In a case where the local jurisdictions have no codes or standards, Mn/DOT standards shall be followed. The drainage design criteria provided herein shall be considered a minimum standard.

As noted in Chapter 3, a comprehensive geotechnical engineering analysis shall be performed to determine the most appropriate measures necessary to achieve these requirements. See Reference Documents for preliminary geotechnical information and recommendations.

16.5.2 Drainage Facilities Design

Unless otherwise provided or required by the local jurisdiction, drainage channels, culverts, BMPs, Ponds, temporary/staging drainage system, and storm sewers shall be designed in accordance with the procedures specified in Mn/DOT's Hydraulic Design Manual, or NPDES standards promulgated by the Minnesota Pollution Control Agency (MPCA). Energy dissipaters, if required, shall be designed not to collect debris.

All new culverts crossing beneath trackbeds shall be capable of passing the peak runoff from a 100-year storm without inundation of the trackbed.

Inundation of the trackbed is defined as a water level above the top of subballast. Storm sewers shall be designed for 10-year storm frequency or applicable agency standards, except new sewer outfalls that carry water from main line sags impacting or created by LRT facilities, which shall be designed for protection of all impacted property from the 100-year storm frequency.

Minimum velocities in pipes, culverts, and concrete-lined channels shall be 2.5 ft per second.

Minimum pipe sizes shall be:

- 18" for culverts under trackways;
- 12" for storm drains which do not connect to open channels;
- 6" for slope drains; and
- 6" for underdrains.

Manholes shall be provided at all changes in direction. Storm drainage facilities in public streets shall conform to the current specifications and standards of the involved local jurisdictions. In a case where the local jurisdictions have no codes or standards, maximum manhole spacing (or culvert length) shall be 400 ft for pipe 36 inches or less in diameter; 600 ft for pipe larger than 36 inches in diameter.

At least a 5'-0" clearance is desirable from the top of rail to the top of all track drainage pipes passing beneath the trackbed, unless otherwise approved by Metro Transit.

Underdrains shall consist of perforated pipe at least 6 inches in diameter for lengths less than 500 ft, and at least 8 inches in diameter for lengths greater than or equal to 500 ft. The perforated pipe shall be surrounded by a minimum of 4 inches of gravel drain material, and placed preferably 12 inches below subgrade. The underdrain system shall also be wrapped with filter fabric (minimum weight 4 oz/sq yd) by placing the fabric between the gravel drain material and the surrounding soil. The fabric shall have a minimum of 12" overlap. To facilitate maintenance, underdrains should be connected at each end to a drainage structure, or provided with cleanouts at regular intervals.

Necessary replacements of existing storm sewers and appurtenances shall provide services equivalent to existing facilities.

Services to adjoining properties shall be maintained by supporting in place, by providing alternative temporary facilities, or by diverting to other points.

All new concrete storm sewer and culvert pipes shall be Class III or better concrete pipe (or equivalent) and gasketed, except pipes crossing under the trackway, which shall be reinforced concrete Class V (or equivalent) and

pipes crossing under roadways, which shall be not less than Class IV. Existing storm drainage piping should be analyzed on a case by case basis.

See Section 14 for information regarding corrosion protection of drainage facilities.

Design of storm sewers shall be done by utilizing an approved modeling package such as Hydrocad, or XPSWMM.

The velocity of flow in culverts shall be no less than 2.5 ft per sec as determined by Manning's Equation:

$$V = \frac{1.486 R^{2/3} S^{1/2}}{n}$$

Where V = Velocity of flow (ft per sec)
 R = Hydraulic radius (ft)
 S = Slope of total head line (ft/ft) (Min. 0.5%)
 n = Manning roughness coefficient

Figure 16-3 gives values of n for various pipe and tunnel materials.

16.5.3 Water Resources Engineering Design

The designer shall research the following data: water quality requirements imposed by local, state and federal government regulations; the project EIS, municipal drainage plans, watershed management plans, records of citizen concerns, localized flooding and maintenance problems associated with drainage.

The designer shall field review the site to become familiar with existing drainage systems, wetlands and other sensitive environmental resources.

The designer shall obtain copies of existing plans and adjacent municipal storm sewer plans to further identify the existing system including culverts and storm sewers affected by the project. The drainage areas and contributing flows shall also be shown on the overview map. The designer shall provide condition ratings on the existing drainage system, and a tabulation of new drainage structures as part of a project-wide hydraulic infrastructure inventory.

The designer shall use the proposed LRT alignment to determine the impact on the existing drainage system and environmentally sensitive areas. The designer will identify the existing drainage patterns and design the proposed drainage system to perpetuate the existing drainage system. In the event that drainage patterns will be changed due to this project, the designer shall coordinate with appropriate agencies to determine if the change in drainage patterns is acceptable to the permitting agencies. The coordination and

resolution of these issues must be documented in the correspondence file. Permit requirements of the applicable stormwater management agency must be followed.

The designer shall locate and design ponds for rate control, water quality and in some cases, water quantity (infiltration).

The designer shall prepare a comprehensive drainage study report documenting the preliminary drainage design and resolution of the water resources issues. This report is to be formatted to stand on its own. The designer shall deliver five hard copies of the report and a copy in electronic format.

The designer shall keep a project log and correspondence file for the project. Copies of all correspondence shall be transmitted to the CCPO as the project is developed.

Storm sewer design is to follow the procedures in Mn/DOT's Drainage Manual, the "Standard Specifications for Highway Construction" and the latest version of "HEC – 22", or the applicable agency's standards. The designer is required to use the cognizant agency's standard spreadsheet format or software program for both the catch basin spacing and the storm drain pipe computation sheets. Storm sewer will be designed to handle the 10 year event with a minimum time of concentration of 7 minutes. All trackway culverts and storm sewers that are located so that future excavation would result in disruption of the LRT train operations, shall be made of concrete gasketed pipe.

Storm sewer system design shall include these items:

- Drainage area maps for each storm drain inlet with pertinent data such as boundaries of the drain inlet with pertinent data such as boundaries of the drainage area, runoff coefficients, time of concentration and land use with design curve number. The drainage sheets shall also document the roadway cross slope and superelevations in accordance with Mn/DOT's standard plan;
- Location and tabulation of all existing and proposed pipe and drainage structures. These include size, class or gauge, catch basin spacing, detailed structure designs, and any special designs;
- Specifications for the pipe bedding material on all proposed pipes and pipe alternates as required for final design plans. The specifications are to be consistent with The Concrete Pipe Technology Handbook, 1993 Edition;
- Complete pipe profiles including: 1) pipe size, type and gradient, 2) station offsets from the centerline of the northbound track, 3) length of pipe, 4) class/gauge of pipe, and 5) numbered drainage structures with coordinate location and elevations;

-
- Class/gauge of pipe along with the final adjustments to be completed after all drainage structures and pipe profiles have been drafted. The designer will determine and draft the existing and proposed ground lines;
 - Water resource engineering related notes, tabulations and specifications are to be per Mn/DOT's sample plan and is to be provided in a format that is easily transferable;
 - A complete set of roadway and trackway cross sections shall be included with the drainage plans. The cross sections shall show the construction staging and associated drainage. Temporary drainage shall be designed to facilitate construction staging; and
 - The Designer shall investigate the adequacy of downstream systems to the extent that they influence the LRT drainage solutions. It is not the intent that the Designer reconstruct restricted downstream systems. However, the Designer must consider reasonable design solutions that mitigate the impact of downstream inadequacies.

Culvert design is to follow the same requirements as the storm sewer design listed above and be designed in accordance with the Hydraulic Design Series No. 5, "Hydraulic Design of Highway Culverts," September 1985, including these items:

- Culverts are to have the bedding designed to reduce frost damage potential as shown in Mn/DOT's "Technical Manual", latest edition;
- Culvert designs as required to maintain drainage and be compatible with the roadway/trackway construction staging plans;
- A waterway analysis and risk assessment using Mn/DOT's form will be required for all centerline culverts larger than forty-eight inches (48") in diameter; and
- Waterway analysis information must be placed on the plan sheets in the standard Mn/DOT format;
- When ponds are required, identify software intended to be used for pond design. Ponding may be required to address water quality, water quantity and rate control issues. Pond designs shall include the following:
 - The design rainfall event for ponds will be the 24 hour, 100 year, SCS Type II rainfall event;
 - A minimum of two feet of vertical freeboard above the 100 year flood elevations will be provided on ponds;
 - All ponds will have an emergency spillway sized to carry events beyond the 100 years event;
 - Dead storage beneath the outlet invert elevation water quality ponds must meet the NPDES or local water planning organization requirements;
 - All inlet and outlet details, skimmers and emergency spillway designs are to be included in the design;

-
- All flood routing will be performed by the designer and calculations will be submitted as required by applicable agencies;
 - Special analysis and documentation will be included for ponds affected by significant environmental issues like hazardous waste or groundwater concerns;
 - A graphic display (both paper and electronic format) showing which areas are treated by each pond;
 - Ditch grades are to be included in all design drawings. When necessary, ditch linings will be designed according to HEC-14, dated September 1983 and Hydraulic Design Series No. 3, “Design Charts for Open Channel Flow,” August 1961; and
 - Bridge deck drainage is considered part of the roadway/trackway drainage.

16.5.4 Software and Design Computations

Metro Transit utilizes AutoCAD and Land Development Desktop software for civil design. Simple drainage designs will typically use the rational method; however, complex watershed modeling normally requires other software.

HydroCAD, XP-SWMM and Visual Hydro by the CAICE can be used to model watersheds. HydroCAD is adequate for modeling where tailwater effects aren't considered. In the case of hydraulically indeterminate situations where tailwater effects exist, XP-SWMM is potentially appropriate. The designer shall use software appropriate to the design requirements and which meet local agency requirements.

Other water related software may be acceptable, but shall be approved Metro Transit prior to start of the work. At the completion of design, a copy of all the hydraulic models in both paper and electronic format will be furnished to the Metro Transit.

The goal of the designer should be to provide a complete set of calculations appropriate to each stage of plan development to ensure ease of review by applicable agencies and Metro Transit.

16.6 PARK-AND-RIDE LOTS

16.6.1 General

Park-and-ride lots are to conform to the appropriate off-street parking requirements of the applicable local jurisdiction and to the provisions of the U.S. Department of Transportation's Transportation for Individuals with Disabilities: Final Rule. Chapter 6 provides standards for roads sidewalks, and parking areas if the local jurisdiction does not have its own standards.

16.6.2 Parking Lot Design

16.6.2.1 Lot Capacity

Parking requirements will typically come from the system ridership model and are to be fulfilled as directed by Metro Transit.. Subsequent reduction or increase in these capacities by more than five percent must be justified, and approval by Metro Transit is required.

Handicapped parking requirements shall be provided based upon the criteria in Section 16.6.2.6. and Minnesota Statutes.

Consideration shall be given to providing smaller than standard size stalls for small cars. These spaces shall be placed in preferential locations to ensure their use by small cars.

16.6.2.2 Circulation

The system of traffic circulation produced by the arrangement of parking aisles and stalls shall be designed to minimize vehicular travel distances, conflicting movements (particularly between buses and passenger vehicles), and number of turns. Vehicular movements within the parking area shall be dispersed by strategic location of entrances, exits, and aisles.

Aisles shall be aligned to facilitate convenient pedestrian movement toward the station (also see Section 6.3.5.). Single tangent aisles shall not be longer than 400 ft. Aisle length may be limited by offsetting aisles, or by changing the aisle alignment.

16.6.2.3 Vehicle Storage Areas

Within the parking lot and immediately adjacent to every entrance and exit to a public street, a reservoir area shall be provided for the momentary storage of entering and leaving vehicles. The momentary storage of vehicles entering or leaving the parking lot shall not interfere with the normal activity of parking and unparking of vehicles at stalls. The reservoir area may be provided in the form of a circulation road and/or an aisle area extending in any direction.

16.6.2.4 Aisles and Parking Stalls

Stall and aisle dimensions for all-day parking shall conform to local jurisdictional code requirements.

Vehicles and other objects shall be excluded from corners of parking lots, where necessary, to provide adequate intersection sight distances.

Areas in which a stall cannot be placed may be used for placement of light standards or for landscaping, if compatible with the overall station design. Small leftover areas that are not landscaped shall be striped with painted lines.

16.6.2.5 Internal Circulation Roads

Circulation roads within a parking lot may be required where normal aisle standards would provide inadequate circulation. See Section 6.4 for applicable dimensions.

Circulation roads shall be curbed. The minimum vehicular inside turning radius shall be 16 ft and the minimum outside turning radius shall be 26 ft.

16.6.2.6 Provisions for Handicapped Parking

Parking facilities for the handicapped shall be provided at a location near the main station entrance. They shall conform to the provisions of the U.S. Department of Transportation's Transportation for Individuals with Disabilities: Final Rule, and Minnesota Statutes.

16.6.2.7 Planted Areas

The total area allocated for landscaping shall be in compliance with the codes and requirements of the local jurisdiction. Landscaping design shall be in accordance with Chapter 5, Landscaping.

16.6.2.8 Lighting

Placement of light poles shall conform to lighting requirements specified in Chapters 6 and 11 and shall be coordinated with the landscaping plan. Light poles should be placed in the following locations:

- In areas not used for parking, such as at the end of rows, adjacent to walkways, or in corners of a lot; and
- In reserved strips between parking stalls.

Where light poles are placed in uncurbed areas or closer than 2'-6" clear to the inside face of the curb, the standard shall be protected by extending the footing a minimum of 2'-6" above the adjacent parking lot surface.

16.6.2.9 Clearances

At the head of the parking stalls, horizontal clearance shall be 2'-6" from the front face of the curb to any obstruction. At the sides of stalls, no horizontal clearance need be provided between stalls and obstructions except at walls, where a one-foot minimum clearance shall be provided.

16.6.2.10 Curbs and Medians

Curbs shall be as specified by the appropriate local jurisdiction or Mn/DOT, barrier-type normally 6" high Design B, constructed of Portland cement concrete. Curbs shall be provided around the entire outer edge of parking lot pavement to protect landscaping or fencing from vehicular damage. Curbs shall also be provided along circulation roads, at raised concrete medians, and at intermediate points in the lots as necessary. Exposed corners of curbs shall have a minimum radius (to face of curb) of 5'-0", or ½ the width of raised medians.

16.6.2.11 Drainage and Grading

Desired minimum cross slope of pavement shall be no less than 2 percent nor more than 5 percent. Preferably no parking stall should have a slope from the head to the back greater than 2 percent. Drainage shall be directed away from areas where pedestrians will walk. Where possible, catch basins should not be located in the aisles.

Along roadways near the station concourse entrances, drainage and grading shall be designed to keep the spread of water flow to a maximum horizontal distance of 2 ft from the face of the curb.

16.6.2.12 Pavement Design

The pavement design for parking areas, circulation roads, bus loading zones, and access roads shall as a minimum conform to the standards set forth by the applicable local jurisdiction or by Mn/DOT.

16.6.2.13 Transit Facilities Design

The design for transit facilities related to park-and-ride lots shall be as described in Chapter 6.

16.6.2.14 EIS

Park-and-ride lots shall conform to the requirements specified in the Environmental Impact Statement (EIS).

16.7 BICYCLE FACILITIES

16.7.1 Codes and Standards

The design of bicycle facilities shall be in accordance with the current specification and design guidelines of the involved local jurisdictions. For those cases where the local jurisdictions have no published requirements, the most recent editions of the following shall be used:

- AASHTO'S Guide for the Development of Bicycle Facilities;

-
- Minnesota Bicycle Transportation Planning and Design Guidelines;
 - Minnesota Road Design Manuals; and
 - Minnesota State Aid Manuals.

16.7.2 General Design Guidelines

The standard Bicycle Trail is to be a paved surface, 12'-0" wide wherever possible, with 2'-0" shoulders of turfgrass or graded and compacted aggregate as appropriate to the site. Provide recommended clearances to lateral obstructions.

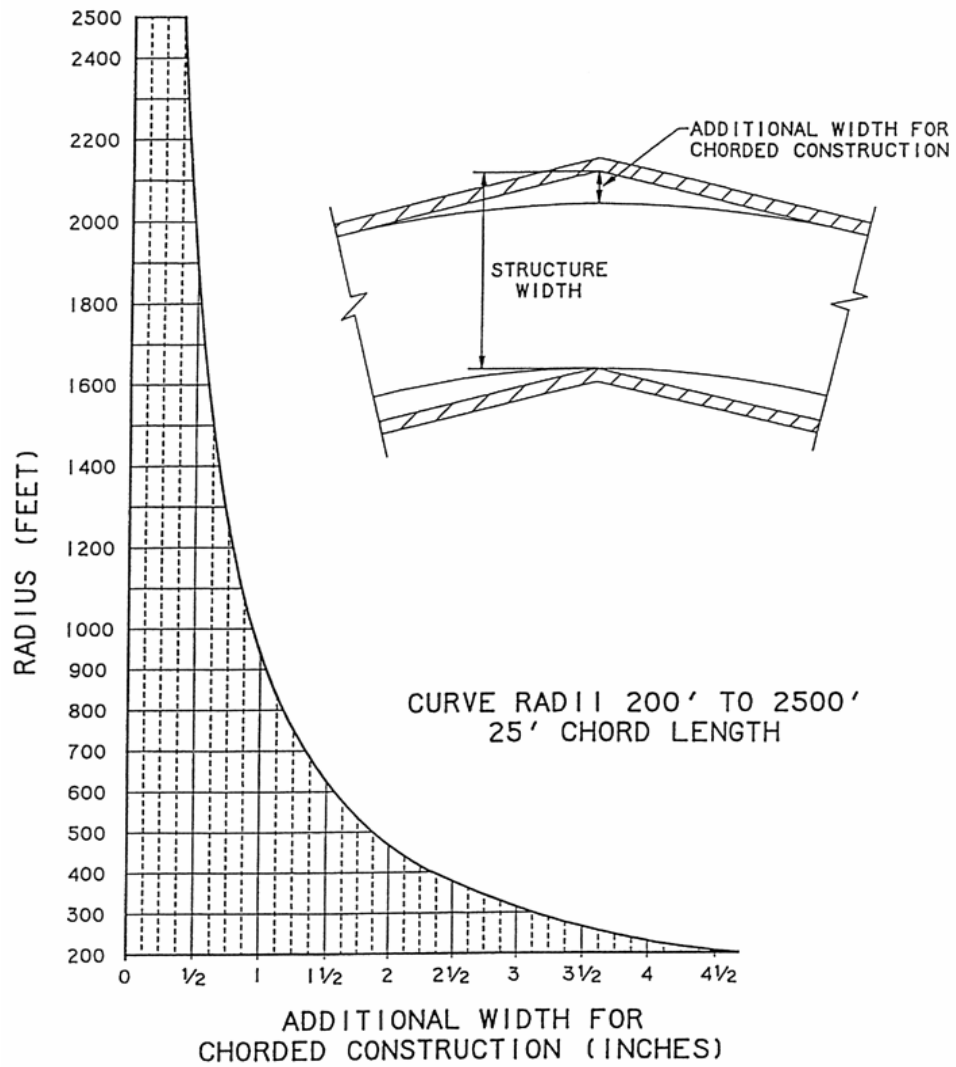

METRO TRANSIT LRT STANDARDS FIGURE 16-1

DESIGN CRITERIA

ADDITIONAL WIDTH FOR CHORDED CONSTRUCTION

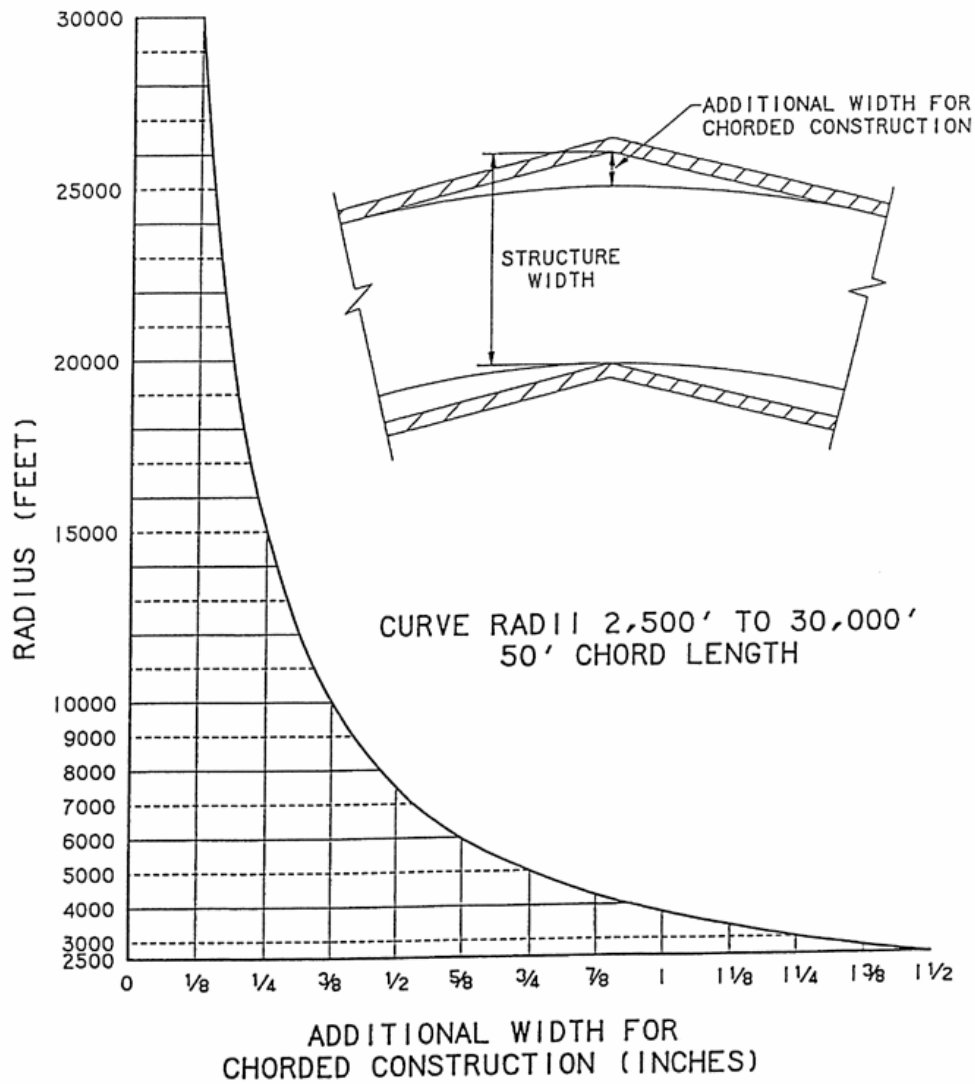

METRO TRANSIT LRT STANDARDS FIGURE 16-2

DESIGN CRITERIA

ADDITIONAL WIDTH FOR CHORDED CONSTRUCTION

MANNING ROUGHNESS COEFFICIENTS

	Manning's n Range
I. Closed conduits:	
A. Concrete pipe	0.011-0.013
B. Corrugated-metal pipe or pipe-arch:	
1. 2-2/3 by 1/2 in. corrugations (riveted pipe):	
a. Plain or fully coated	0.024
b: Paved invert (range values are for 25 and 50 percent of circumference paved):	
(1) Flow full depth	0.021-0.018
(2) Flow 0.8 depth	0.021-0.016
(3) Flow 0.6 depth	0.019-0.013
2. 6 by 2 in. corrugation (field bolted)	0.03
C. Cast iron pipe, uncoated	0.013
D. Steel pipe	0.009-0.011
II. Gutters and tunnel inverts	
A. Concrete gutter, troweled finish	0.012
B. Asphalt pavement:	
1. Smooth texture	0.013
2. Rough texture	0.016
C. Concrete gutter with asphalt pavement:	
1. Smooth	0.013
2. Rough	0.016
D. Concrete pavement:	
1. Float finish	0.014
2. Broom finish	0.016
E. For gutters with small slope, where sediment may accumulate, increase above values of n by 0.002	

Note: For a complete listing of Manning Roughness Coefficients refer to the Mn/DOT Drainage Manual

METRO TRANSIT LRT STANDARDS FIGURE 16-3

DESIGN CRITERIA

ROUGHNESS COEFFICIENTS

17.0 TRAFFIC ENGINEERING

17.1 TRAFFIC SIGNAL SYSTEMS

17.1.1 General

17.1.1.1 Scope

This section establishes the basic traffic engineering criteria to be used in the design of traffic signal systems affected by the Central Corridor Light Rail Transit (CCLRT) System . New traffic signal systems and revisions to existing traffic signal systems will be required as part of the project. The criteria for the design of traffic signal systems will include general operation, hardware, and software functional requirements, guidelines for development of a traffic control strategy and signal timing plan, and LRT priority system testing.

The following is a list of the primary stakeholders that may have an interest in the design and operation of the traffic signal systems affected by the LRT line.

- City of Minneapolis;
- City of Saint Paul
- Minnesota Department of Transportation;
- Metro Transit;
- Ramsey County; and
- Hennepin County.

17.1.1.2 Standards

Traffic signal systems shall be in accordance with the Contract documents and with the standards and practices of the stakeholder having jurisdiction over the specific traffic signal system. The most current version of the following standards in effect at the time of proposal submission shall be used:

- Minnesota Manual on Uniform Traffic Control Devices (MMUTCD);
- Standard Specifications for Structural Support for Highway Signs, Luminaires, and Traffic Signals, AASHTO;
- National Electrical Code;
- Preemption of Traffic Signals at or near Railroad Grade Crossings, ITE;
- Mn/DOT Technical Memorandum, Guidelines for the Inspection and Operation of Railroad Preemption at Signalized Intersections; and
- Part 10, “Traffic Controls for Highway Light-Rail Transit Grade Crossings”, Manual on Uniform Traffic Control Devices (MUTCD).

17.1.1.3 References

The following references will be useful in designing traffic signal systems for the project:

- Mn/DOT Traffic Engineering Manual;
- Highway Capacity Manual, Special Report 209; Transportation Research Board, 1998;
- Minneapolis Sample Signal Plan;
- St. Paul Sample Signal Plan
- Mn/DOT Sample Signal Plan;
- As-built plans for existing traffic signal systems; and
- Mn/DOT Metro Division web site:
<http://www.dot.state.mn.us/metro/trafficeng>.

17.1.1.4 Definitions

Preemption Operation—Traffic signal system operation that provides for the transfer of right of way to an LRT vehicle (LRV) at the LRT-highway grade crossing with no delay to the LRV. This is the same as railroad preemption at signalized intersections.

Advance Preemption Operation—Traffic signal operation that starts highway traffic signal preemption sequences before railroad warning devices are activated at the railroad crossing. The MUTCD requires a 20-second minimum time for the railroad circuit to activated warning devise prior to arrival of the through train. The basic 20 seconds may not be sufficient when highway traffic signals are interconnected to a railroad crossing with active warning devices. A variety of items should be considered when designing time elements for a preemption operation including the approach speed of trains and vehicles, the intersection and crossing geometry, vehicle volumes, train frequencies, train stops, vehicle queue length and dissipation rates, design vehicles, pedestrian intervals, minimum green times, types of active warnings, and variability in warning time provided due to changes in the speed of the train. Advance preemption is necessary where the right-of-way transfer time, queue clearance time, and separation time exceed the railroad warning time, and the clear storage distance exceeds approximately 80 feet (adequate storage distance for a 65-foot tractor-trailer combination). Advance preemption also may be required where this distance is less than 80 feet to prevent vehicle-gate interaction (striking the vehicle with the descending gate arm) or to prevent turning vehicles approaching the crossing from the intersection side from blocking the exit path of vehicles attempting to vacate the crossing during track clearance green.

Priority LRV Operation—A traffic signal system operation that provides preferential treatment for the progression of the LRV over the vehicles at a signalized intersection. Priority LRV Operation maintains signal coordination for roadway traffic but also includes measures that will attempt to facilitate

LRV progression along the segment. The Priority LRV Operation of the traffic signal systems will be designed with features, such as early recall to the LRV phase or green extension for the LRV phase, that will give preference to LRV progression, but will not disrupt traffic signal coordination.

Standard Active Control Devices—Standard Active Control Devices give advance notice of the approach of a train. They are activated by the passage of a train over detection circuitry in the trackway, except in those few situations where manual control or manual operation is used. Standard Active Control Devices include flashing light signals (both mast-mounted and cantilevered), bells, automatic gates, active advance warning devices, and highway traffic signals. These devices are supplemented with signs and pavement markings, which are referred to as passive control devices.

Supplemental Active Control Devices --- Supplemental Active Control Devices provide advanced notification of an approaching train and are activated by the passage of a train over detection circuitry in the trackway, except in those few situations where manual control or manual operation is used. Supplemental Active Control Devices include advanced warning signs with flashers, active second train coming sign (blank-out sign with internal illumination) displaying "Look Both Ways" with a double arrow or Flashing LRV Symbol with a double headed arrow, active turn restriction sign (blank-out sign with internal illumination) displaying "No Right Turn " or "No Left Turn " (or appropriate international symbol), active "Do Not Stop On Tracks" sign (blank-out sign with internal illumination), automated pedestrian gates, pedestrian signals, and variable message signs.

Dynamic Envelope—Clearance area required for the light rail transit vehicle overhang resulting from any combination of loading, lateral motion, or suspension failure.

Traffic Adaptive System—Traffic systems that have the ability to monitor traffic conditions and implement appropriate timing plans that best serve the current traffic needs.

Emergency Vehicle Preemption—Traffic control system provides for the transfer of right-of-way to an emergency vehicle. The transfer of right-of-way promptly displays green signal indications at signalized locations equipped with emergency receivers ahead of the emergency vehicle that has been equipped with the detection emitter device. Emergency vehicles may include, fire vehicles, law enforcement vehicles, ambulances, and other official emergency vehicles. Emergency vehicle preemption takes precedence and will over-ride Priority LRV Operation.

Level of Service—A qualitative measure describing operational conditions within a traffic stream, based on service measures such as speed and travel

time, vehicle delay, freedom to maneuver, traffic interruptions, comfort , and convenience.

17.1.2 Design Guidelines

17.1.2.1 General

Traffic signal system designs shall incorporate input from the stakeholders having jurisdiction over the signal system. A traffic signal system plan shall be prepared for each new or revised traffic signal system. The traffic signal system plan shall be in a format acceptable to the stakeholder having jurisdiction over the signal system and shall be certified by a registered Professional Engineer in the State of Minnesota. The traffic signal system plan for each traffic signal system shall be submitted to the Project Manager (PM) the stakeholder for review, and a written statement of no objection from the stakeholder for the plan shall be obtained prior to advertisement of the specified traffic signal system.

The traffic signal systems design shall integrate the LRT detection and operating scheme defined and approved by the PM and stakeholders, including as necessary the authorized emergency vehicle detection and LRT preemption and/or priority capabilities. LRT preemption/priority features and functions shall be compatible with signal system hardware and software currently being used or as approved by the stakeholders.

Signal controllers compatible with existing hardware and software, used by the respective stakeholders having jurisdiction over the signal system, shall be utilized. It should be determined through the design process if the stakeholders will furnish to the Contractor, at the Contractor's expense, a fully tested traffic signal system cabinet complete with actuated controller unit and all required signal control equipment or whether the Contractor shall fully test all traffic signal system cabinet complete with actuated controller unit and all required signal control equipment. The traffic signal system designer will develop field wiring diagrams as part of the traffic signal plans that are approved by the agency responsible for maintenance and operation. The designer will work with the agencies to ensure the field wiring diagrams support the controller cabinet fusing arrangement for the type of controller being used. The Contractor shall provide 90-day advance notice to these stakeholders to establish when the traffic signal cabinet and controller will be needed for a particular traffic signal system.

Traffic signals, pedestrian signals, and any special LRT signs and signals required shall be designed and installed in accordance with the specified standards and the Construction Specifications. Where LRT vehicles will be operating on existing streets mixed with general traffic, LRT signals shall be provided and shall be distinct (lunar white bars) in both appearance and indication from traffic signals controlling motorists and pedestrians. Any new

or revised vehicle or pedestrian indications shall utilize a light-emitting diode (LED) unit in accordance with the latest issue of ITE and agency standards.

Where there are existing cables interconnecting traffic signals, they will be utilized, where possible. Existing signalized intersection locations that are modified/replaced as part of the LRT design will have new fiber interconnected as part of the traffic signal system to handle the additional functionality required by the LRT system. New traffic signals shall be integrated into the existing system.

The City of Minneapolis will be installing new systems for monitoring and control of traffic signals. The city will be installing a new traffic adaptive system in southeast Minneapolis (SCOOT system) in conjunction with the new University of Minnesota stadium. Interface to that system will need to be researched and developed by the traffic signal system designer. Any traffic signal systems designed for Minneapolis shall be connected to the City's control systems and shall be compatible with the City's equipment.

The City of Saint Paul operates a central control system for traffic signals using the Econolite Pyramids system. The central system communicates with and manages all traffic signals that will be directly or indirectly affected by the Central Corridor LRT line in Saint Paul. Interface to that system will need to be researched and developed by the traffic signal system designer. Any traffic signal systems designed for Saint Paul shall be connected to the City's control systems and shall be compatible with the City's equipment.

Any new or revised traffic signal system shall include authorized emergency vehicle preemption (EVP) detection equipment compatible with the EVP emitter equipment of the appropriate stakeholder. EVP equipment shall be compatible with EVP equipment of the stakeholder.

Pedestrian capacity and control at crosswalks must be considered. Where pedestrian-actuated traffic signals are provided, they shall be designed to regulate pedestrian crossings of the roadways. Pedestrian push buttons shall be provided to actuate those pedestrian signals. Pedestrian signal indications shall display international symbols.

The traffic signal designer will be responsible for coordinating with the appropriate local utility company to determine the source of power and the utility company's requirements for each new or revised traffic signal system.

The traffic signal designer shall coordinate the signal design with the bridge design for the signalized intersections near new proposed bridges to determine if revisions or additions to the traffic signal equipment are necessary to accommodate the bridge structure and to assure adequate visibility of the traffic signal indications.

The traffic signal designer shall coordinate the signal design with the LRT gates/signals design. This may require modifications to the roadway design to assure adequate space is provided for both the signal system and the LRT gates/signal system at a signalized intersection at or near an at-grade LRT crossing. Such roadway modifications should be limited to existing right of way limits. Visibility of traffic signals and LRT crossing signals shall be considered in the design of the systems.

The traffic signal system design shall be coordinated with the design of the LRV detection systems. The traffic signal system design shall include, but is not limited to:

- Developing detector location layout sheets showing the detector location with respect to the LRT station and roadway intersection, connectivity route to the traffic signal controller cabinet, general traffic vehicle detectors, and various existing utility locations;
- Developing details, if any, as to how the LRT detectors connect to the traffic signal controller assembly; and
- Developing LRV detection equipment capable of transmitting LRV detections to the traffic control system, to take full advantage of its priority provision capabilities.

Where the traffic signal system design will require the removal of existing traffic signal system equipment, the existing traffic signal system equipment shall be salvaged or abandon in accordance with the stakeholders provisions. Any salvaged traffic signal system equipment shall be delivered to the stakeholder having jurisdiction over the traffic signal system.

17.1.2.2 Traffic Control Strategy

Maintaining LRV progression through the corridor is important to preserving the operational integrity of the LRT system. Equally important on some highway segments is maintaining highway signal coordination along parallel streets and cross streets affected by LRT at-grade crossings. A traffic control strategy addressing the concerns of LRV progression and highway signal coordination shall be developed by the traffic signal designer. The development of the traffic control strategy shall incorporate input from the stakeholder having jurisdiction over the affected traffic signal systems. Strategy reports shall be developed prior to final design of the signal system components and a definition of intersection operations including analysis of downtown operations with central corridor trains added. An agency and stakeholder's Memorandum of Understanding (MOU) agreement for the proposed strategy shall be secured before implementation.

Specific traffic control strategies should be developed for each LRT segment. Traffic control strategies for LRT segments affected by large venues should account for event traffic.

The goal of the traffic control strategy is to provide LRV progression while maintaining integrity for roadway traffic operations. Signal design shall use a separate phase for LRT movements, where appropriate to avoid conflicts. It shall be the designer's responsibility to determine the phasing at each intersection that the LRVs pass through. Such a design process shall include a determination of whether the LRV requires a phase of its own, or whether it can run concurrently with parallel traffic (compatible traffic phase.), as well as all vehicular and pedestrian movements. Such an analysis shall be based on operational as well as safety considerations, and the results shall be reviewed and approved by the stakeholder having jurisdiction over the signal systems. Adjacent traffic signals on cross streets shall be coordinated as deemed appropriate by traffic engineering analysis and consultation with stakeholders.

If a traffic signal system is already in a preemption sequence and a second train calls for preemption, the traffic signal system will initiate another track clearance phase, if there is sufficient available time before the second train arrives at the crossing. If sufficient time is not available before the second train arrives, the traffic signal will hold the roadway traffic in a mode that will keep vehicles off the tracks.

The traffic signal designer shall submit operational parameters to the PM at the conceptual stage for review and to receive a statement of no objection.

17.1.2.2.1 Type of Operation by Segment

Three types of traffic signal operation are defined in Section 17.1.1.5. The types of operation are Preemption Operation, Advance Preemption Operation, and Priority LRV Operation. In developing the traffic control strategy, the traffic signal designer shall incorporate input from the stakeholder having jurisdiction over the signal system. Each segment of the LRT corridor shall be evaluated to determine which operating type will provide the most efficient and progressive operation for the LRT system and overall transportation system. The impacts to the local street network will be evaluated in coordination with the LRT.

17.1.2.2.2 Standard Active Warning Devices

Standard Active Warning Devices are discussed in Section 12 "Signal System" of this document.

17.1.2.2.3 Supplemental Active Warning Devices

Supplemental active warning devices may be utilized as provided in Section 4 of the Railroad-Highway Grade Crossing Handbook including:

- Active Advance Warning Sign (AAWS): Consists of one or two 12-inch yellow hazard identification beacons mounted above the advance

warning sign. An advisory speed plate sign indicating the safe approach speed also should be posted with the sign. The AAWS provides motorists with advance warning that a train is approaching the crossing. The beacons are connected to the railroad track circuitry and activated on the approach of a train. AAWS should be considered at locations where the crossing flashing light signals cannot be seen until an approaching motorist has passed the decision point (the distance from the track from which a safe stop can be made). AAWS should be placed at the location where the advance warning sign would normally be placed. To enhanced visibility at crossings with unusual geometry or site conditions, the devices may be cantilevered or installed on both sides of the highway. An engineering study should determine the most appropriate location.

- “Second Train Coming” Active Warning Sign: Train detection systems can also be used to activate a “Train Coming” supplemental warning sign. This sign is used on a limited basis, normally near commuter stations where multiple tracks and high volumes of pedestrian traffic are present. The sign activates when a train is located within the crossing’s approach circuits and a second train approaches the crossing.
- Active Turn Restriction Signs: At a signalized intersection located within 60 meters (200 feet) of a highway-rail grade crossing, measured from the edge of the track to the edge of the roadway, where the intersection traffic control signals are preempted by the approach of a train, all existing turning movements toward the highway-rail grade crossing should be prohibited during the signal preemption sequences. A blank-out or changeable message sign and/or appropriate highway traffic signal indication or other similar type sign may be used to prohibit turning movements toward the highway-rail grade crossing during preemption.
- Active Do Not Stop on Tracks Sign: A blank-out or changeable message sign and/or appropriate highway traffic signal indication or other similar type sign may be used to warn drivers not to stop vehicles on the tracks.
- Active Pedestrian Warning Devices: Passive and active devices may be used to supplement standard active control devices to improve non-motorist safety at LRT crossings. Passive devices include fencing, swing gates, pedestrian barriers, pavement markings and texturing, refuge areas and fixed message signs. Active devices include flashers, audible active control devices, automated pedestrian gates, pedestrian signals, variable message signs and blank out signs. These devices should be considered at crossings with high pedestrian traffic volumes, high train speeds or frequency, extremely wide crossings, complex highway-rail grade crossing geometry with complex right-of-way assignment, school zones, inadequate sight distance, and/or multiple tracks. All pedestrian facilities should be designed to minimize

pedestrian crossing time and devices should be designed to avoid trapping pedestrians between sets of tracks.

17.1.2.2.4 Roadway Requirements

In developing the traffic control strategy, the designer shall meet the following requirements for roadway operations:

- For opening day operations, all signalized intersections in each Segment shall operate at an acceptable level of service (LOS) as approved by the local agencies. LOS shall be as defined in Chapter 9 of the Highway Capacity Manual (HCM), 2000;
- The designer shall attempt to minimize the amount of time that traffic is prevented from crossing the tracks due to approaching LRV movements; and
- For those intersections at which LRT affects the operation of the signal system by preemption, the goal is to have the minimum time between consecutive calls for preemption – from the end of one call to the beginning of the next call – be greater than or equal to the minimum time required to serve all movements, including pedestrians, not served during the preemption. If the preceding condition cannot be met, then the maximum time for consecutive preemption calls to be in effect shall be limited as follows: the time from the end of green for any movement prior to the first preemption call being received to the start of green for the same movement after the second preemption call is terminated must not exceed 2 times the minimum cycle length for the intersection. The minimum cycle length calculation assumes all phases at the intersection are served.

17.1.2.2.5 Pedestrians and Bicycles Requirements

Sight triangle evaluations and selection of appropriate warning devices such as active warning devices should be considered in order to accommodate pedestrian activity at LRT crossings. Channelization to direct pedestrians to designated crossing points shall be evaluated. Correct crossing control for pedestrians should also be considered including the use of a stop line/tactile strip at the limit of the dynamic envelope.

Bicyclists should be directed by signs to dismount in station areas in order to avoid potential collisions with pedestrians. Signs should also preclude mounted cyclists from using pedestrian crossings. Channelizations and signs should be used to maintain bicycle speeds at appropriate levels.

17.1.3 Signal Timing Plan Development

Signal timing plans shall be developed in coordination with the Agency stakeholders for AM peak, Mid-day peak, PM peak, AM off-peak, and PM

off-peak using actual current traffic count and turning movement data. Up to two event timing plans may be developed if the corridor serves large event venues that street the transportation system (University Avenue). Timing plans will be developed by the traffic signal designer using modeling software approved by the agencies.

17.2 TRAFFIC SIGNS AND PAVEMENT MARKINGS

17.2.1 Scope

This section establishes the traffic engineering criteria to be used in the design of traffic signs and pavement markings for roadways affected by the LRT line. New traffic signs and pavement markings; removal, salvage, and relocation of existing traffic signs; and removal and replacement of existing pavement markings will be required as part of the project. Traffic signing and pavement marking shall meet the traffic movement and informational needs of motorists and pedestrians.

The following is a list of the primary stakeholders that will have an interest in the design and installation of the traffic signs and pavement markings on the roadways affected by the LRT line:

- City of Minneapolis;
- City of Saint Paul
- Minnesota Department of Transportation;
- Metro Transit;
- Ramsey County; and
- Hennepin County.

17.2.2 Standards

Traffic signs and pavement markings shall be in accordance with the standards and practices of the stakeholder having jurisdiction over the affected roadway. The most current version of the following standards in effect at the time of proposal submission shall be used:

- Minnesota Manual on Uniform Traffic Control Devices (MMUTCD);
- Standard Specifications for Structural Support for Highway Signs, Luminaires, and Traffic Signals, AASHTO;
- Mn/DOT Standard Signs Manual;
- Mn/DOT Traffic Engineering Manual; and
- Part 10, “Traffic Controls for Highway Light-Rail Transit Grade Crossings”, Manual on Uniform Traffic Control Devices.

17.2.3 Traffic Signing and Pavement Marking Plan

The designer must conduct a field review of all in-place traffic signs and pavement markings along the roadways affected by the LRT line. The designer shall document the type, location, and condition of traffic signs and pavement markings that may be disturbed by construction of the project or may need to be revised as a result of the design.

The design of traffic signs and pavement markings shall be coordinated with the stakeholder having jurisdiction over the affected roadway. A traffic signing and pavement marking plan shall be prepared by the designer detailing with all new or revised traffic signs and pavement markings required for the project. The traffic signing and pavement marking plan shall be certified by a registered Professional Engineer in the State of Minnesota. The traffic signing and pavement marking plan shall be submitted for review and approval by Metro Transit and local agencies.

Traffic signs and pavement markings required shall be designed and installed in accordance with the specified standards of the local agency. Existing traffic signs that are proposed to be removed may be salvaged and re-used, if the stakeholder having jurisdiction over the roadway agrees that the signs are in acceptable condition.

The pavement marking material to be used on new roadways shall be new and of the type designated by the local agency. The local agency shall determine if side street roadway conformities shall receive new pavement marking material or the same type as in-place pavement marking material on the existing roadway. For any new signs, sign face material for sign panels shall be Direct Applied Wide Angle Prismatic Retroreflective Sheeting for Visual Impact Performance (VIP sheeting) manufactured by 3M Company. Signs should be located and mounted in accordance with MUTCD, state, and local requirements. Signs shall not be mounted on bridges unless doing so will not violate architectural requirements. Details of bridge-mounted signs shall be included with the bridge drawings. Signs may be mounted on existing structures only with the approval of the owning stakeholder.

18.0 STRUCTURES

18.1 GENERAL

This section establishes the basic criteria for the design of Buildings and Transportation Structures. Transportation Structures include non-building structures subject to Light Rail Vehicle (LRV) loading or highway loading, supporting structures for aerial stations, retaining walls, barriers, railings and fencing detached from buildings, noise walls, substation screen walls, sign structures, luminaire supports, and drainage structures. These structures are typically designed in accordance with AASHTO publications or the AREMA Manual. Foundations for catenary structures are covered in Section 10.6.8. Buildings and non-transportation structures include yard and shop facilities, stations, buildings associated with stations, pedestrian skyway structures, and miscellaneous structures that are generally subject to the Minnesota State Building Code. Building structures may be subject to LRV loads, either directly, as components of a maintenance or storage facility are, or indirectly through a live load surcharge from tracks adjacent to the structure. Applicable structural criteria are contained herein, excluding the structural criteria for the Overhead Contact System (OCS) and catenary structures, and tunnel and mined facility construction, which are specified in Sections 10.6 and 7, respectively, of this criteria. Utility vaults, bus shelters, and prefabricated structures housing substation, signal, and communication equipment, and their foundations, are included under Section 312, Utility and Miscellaneous Group U, of the Minnesota State Building Code and the International Building Code. The design and construction of all structural systems and components shall provide functionality, durability, ease of maintenance, safety, code compliance, regulatory compliance, ease of expansion and retrofit, and pleasant aesthetics.

Design Criteria can not address all potential applications of various and sometimes conflicting design codes, manuals, and practices. Engineering judgment and efforts to build consensus on the prudent and proper design methodologies is required. Some structures proposed for use on the Central Corridor are owned by other agencies, for example, Hennepin County owns the Washington Avenue Bridge, and Mn/DOT owns the University Avenue Bridge and the Cedar Street Bridge over I-94 and I-35E. Designs on structures not owned by the Metropolitan Council or Metro Transit are subject to stakeholder reviews by the structure's owner's Engineer or its duly appointed representative.

All light rail vehicle clearance requirements are specified in Section 8.5, and Appendix A. Clearances for the contact wire and the pantograph are included in Appendix B. Clearances for highways and roadways are included in Section 16.3. The Designer is reminded that these requirements must be adhered to in the design of all structures and therefore no additional references to final clearances are made in this section.

18.1.1 Design Interfaces

Rail transit systems involve numerous interfaces which impact the design of structures. The designer is encouraged to become familiar with the entire design criteria document to become aware of and reconcile the interfaces. Explicit references

to other sections of these design criteria will be made, but this does not relieve the designer of the responsibility to identify and reconcile conflicts created by the interfaces.

Trackwork/Track Geometry	see: Section 3, Track Geometry and Trackwork Section 3.1.2, Construction Tolerances Section 3.1.5, Stray Current Control Section 3.4.13, Embedded Track Section 3.4.14, Direct Fixation Track Section 3.4.19, Transition Slabs Section 3.4.20, Rail Expansion Joints
Traction Power	see: Section 10, Traction Electrification System Section 10.5.14, DC Underground Dist. Feeders
Overhead Contact System	see: Section 10.6, Overhead Contact System Section 10.6.9, Foundations (Pole Bases) Section 10.6.10, Poles and Supporting Hardware Section 10.6.12, Bridge Supports Section 10.6.19, Protective Screening
Lighting	see: Section 11.5, Electrical Systems Lighting
Grounding	see: Section 11.6, Electrical Systems Grounding
Train Control Signals/Signs	see: Section 12, Signal System
Communications	see: Section 13, Communications & Central Control
Stray Current/Corrosion Control	see: Section 14, Stray Current/Corrosion Control see: Section 14.2.7, Structures and Facilities Test
Stations	see: Section 6, Station Area and Facility Req.
Roadway clearances	see: Section 16.3, Clearances
Drainage	see: Section 16.5, Drainage
Traffic signs and signals	see: Section 17.2, Traffic Signs and Pav. Markings
Site Guidance Signs	see: Section 6.8, Site Signs and Graphics
Utilities and Ductbanks	see: Section 4, Utilities see: Section 11, Electrical Systems see: Section 11.7, Conduits and Ductbanks
Safety, Security, and Emergency Egress	see: Chapter 2, Fire/Life Safety see: Section 2 - 3.4, Means of Egress
Architecture and Aesthetics	see: Section 6.11, Public Art

18.2 DESIGN CODES, MANUALS, AND SPECIFICATIONS

The design and construction of structures shall be in accordance with these criteria and the relevant requirements of the cited design codes, manuals, and specifications listed herein. Should the requirements in any reference conflict with those in another, the order of precedence shall be as defined by Section 18.2.1 and 18.2.2 unless specifically noted otherwise. Recognized codes, manuals, guide specifications, and other documents may be used to supplement the lists included below.

18.2.1 Transportation Structures

For transportation structures, the following documents shall be adhered to in the following order of precedence:

- Minnesota Department of Transportation LRFD Bridge Design Manual, with current revisions
- AASHTO LRFD Bridge Design Specifications, 4th Edition and Current Interims or AASHTO Standard Specifications for Highway Bridges, 17th Edition. and current interims;
- AREMA Manual for Railway Engineering, 2005 and Current Interims, hereinafter referred to as AREMA;
- AASHTO Standard Specifications for Structural Supports for Highway Signs, Luminaires and Traffic Signals, 4th Edition and Current Interims;
- AASHTO Manual for Condition Evaluation of Bridges, Second Edition, 1994 and Current Interims;
- AASHTO Guide Specification for Pedestrian Bridges, 1st Edition;
- AASHTO Guide Specification and Commentary for Vessel Collision Design of Highway Bridges;
- AASHTO Guide Specifications for Structural Design of Sound Barriers, 1992 and Current Interims; and
- Bridge Welding Code: AASHTO/AWS D1.5M/D1.5, 2002, An American National Standard, 4th Edition and Current Interims,

18.2.1.1 Design Methodology

Except as otherwise noted in this document, design shall be in accordance with the following:

- For steel LRT bridges, the design methodology shall be the Load and Resistance Factor Design Method, utilizing Strength II load factors for LRV and Maintenance Train Loadings, which is 1.35;
- For concrete bridges and portions thereof, the design methodology shall be the Load and Resistance Factor Design Method with load factors as described above;
- All retaining wall designs shall address internal stability, external stability, global stability and liquefaction.; and
- For structures that are subject to a combination of loads, use the multiple presence factor based on the total number of individual lanes loaded, tracks loaded, and other moveable loads (such as pedestrian loads and snow loads).
- For structures that are subject to a combination of loads, use the load factor for AASHTO LRFD Strength II for LRV's and Maintenance Trains, and the Load Factor for AASHTO LRFD Strength I for all other loads. The load factor for Strength II recognizes the low probability of an LRV exceeding the AW4 load included in Figure 18-1. The weight of LRV's is more accurately known, the passenger loading limit can not be physically exceeded, and

Metro Transit has very high control over the vehicles and future vehicles. Further, the LRV loading is not a notional load, but is a loading configuration known with a high degree of certainty. These differences are very significant compared to the limited control over truck weights and configurations that most bridge owners have which requires a higher load factor to increase the probability that design load will not be exceeded during the life of the bridge.

For existing bridges that are not substantially reconstructed, use the Load Factor Design Method for rating the structure, as Mn/DOT and most other agencies have not transitioned to Load and Resistance Factor Rating (LRFR). The Methodology is included in the AASHTO Manual for Condition Evaluation of Bridges.

18.2.2 Buildings

For buildings, the current Minnesota State Building Code, the Amendments to the Minnesota State Building Code, and the adopted International Building Code shall be followed.

For other reinforced concrete and prestressed concrete structures not specifically covered by the Minnesota State Building Code, the Building Code Requirements for Reinforced Concrete and Commentary (ACI 318-05) hereinafter referred to as “ACI”, shall be followed.

For masonry and reinforced masonry structures not specifically covered by the Minnesota State Building Code, the Building Code Requirements and Specifications for Masonry Structures and Commentary (ACI 530/530.1-05) shall be followed.

For other steel structures not specifically covered by the Minnesota State Building Code, the Steel Construction Manual, 13th Edition, allowable stress design or load and resistance factor design American Institute of Steel Construction, hereinafter referred to as AISC, shall be followed.

For timber structures not specifically covered by the Minnesota State Building Code, the National Design Specification for Wood Construction, by the National Forest Products Association, hereinafter referred to as NDS, shall be followed.

For overhead traveling cranes, C.M.A.A. Specification 74, shall be followed.

18.2.2.1 Fire Hazard Rating

For fire hazard rating information see Section 2, Fire/Life Safety.

18.3 MATERIALS

18.3.1 Materials for Transportation Structures

Materials shall conform to the requirements of the Minnesota Department of Transportation, Standard Specification for Construction, 2005 and current revisions.

18.3.1.1 Concrete

Concrete mixes specified shall conform to the current practices listed in Section 5 of the Mn/DOT LRFD Bridge Design Manual, Table 5.1.1.1 and Table 5.1.1.2.

Commonly used concrete mixes include:

- Railings, Medians and Sidewalks 3Y46A
- Deck or Slab (without wearing course) 3Y33
- Deck or Slab (with wearing course) 3Y36
- Concrete Wearing Course 3U17A
- Precast Concrete (other than slab) 3W36 or approved mix
- CIP Post-Tensioned Concrete (other than slab) 3U36 or approved mix
- CIP Post Tensioned Concrete (slab) subject to approval
- Substructure Columns, Caps, and Walls 3Y43
- Footings 1A43
- Fill beneath Spread Footings on Rock 1C62
- CIP Retaining Walls 3Y43
- Concrete for CIP Piles 1C62
- Approach Panels and Transition Slabs 3Y33

Maximum allowable concrete strengths for precast prestressed concrete may be 7500 psi initial strength and 9000 psi final strength in accordance with current Mn/DOT policy (Mn/DOT LRFD Bridge Design Manual, Section 5.4.3 for current limits).

18.3.1.2 Reinforcing Steel

Stray current control considerations may require the use of rebar mats that are welded to provide electrical continuity. When reinforcement will be welded, it shall conform to ASTM A706.

When the reinforcement is sufficiently isolated from stray current, the use of rebar conforming to ASTM A165, Grade 60 may be used in accordance with Mn/DOT policy.

In locations utilizing direct fixation track, consider the use of glass fiber reinforced rebar (GFRB) in the concrete plinths to maximize electrical isolation of the structural deck from the track.

18.3.1.3 Structural Steel

Structural Steel shall conform to the requirements of the Mn/DOT LRFD Bridge Design Manual (Section 6.1) and to the requirements of the Minnesota Department of Transportation Construction Specifications, Section 2471.2. High Performance Steel (HPS) is available from a limited number of suppliers in the sizes required for bridge construction. This could increase the cost and schedule for fabrication. Verify cost and schedule constraints prior to specifying HPS.

All bolted connections shall be made with ASTM A325 bolts.

18.3.2 Materials for Buildings

18.3.2.1 Concrete

Concrete shall be proportioned to provide an average compressive strength as prescribed below:

<u>Design Strength</u>	<u>F'c (psi) 28 Days</u>
All CIP Concrete	4,000 psi (min) – 5,500 psi (max)
Prestress Concrete	7,000 psi initial (max) – 8,500 psi final (max)

18.3.2.2 Reinforcing Materials

All reinforcing steel shall conform to ASTM A615 – grade 60.

Concrete cover requirements and corrosion protection shall conform to the Building Code Requirements for Reinforced Concrete (ACI 318).

18.3.2.3 Structural Steel

Structural Steel Shapes and Plates shall conform to ASTM A36, ASTM A572, or A588. Structural Tubing and Steel Pipe shall conform to ASTM A500 or A618.

Structural Bolts shall conform to ASTM A307 or A490. Anchor Bolts shall conform to ASTM A307.

18.3.2.4 Dimension Lumber

Wood design stresses shall be base design values for visually graded lumber. Lumber shall be seasoned to 19 percent maximum moisture content at the time of dressing. Lumber species and grade required for design loads shall be clearly indicated on the plans.

18.3.2.5 Concrete Masonry

- Hollow Load Bearing Concrete Masonry Units shall conform to ASTM C90;
- Hollow Non-Load Bearing Concrete Masonry Units shall conform to ASTM C129;
- Solid Load Bearing Masonry Units shall conform to ASTM C145; and
- Grout for Reinforced and Non-Reinforced Concrete Masonry shall conform to ASTM C476.

18.4 LOADS AND FORCES

Loads for structures shall be in accordance with the previously specified Design Codes, Manuals, and Specifications except as otherwise noted or modified herein.

18.4.1 Transportation Structures

The following loads and forces, as described in the AASHTO LRFD Bridge Design Specification and the AREMA Manual for Railway Engineering, shall be considered when designing structures:

D	=	Dead Load For System Wide Equipment Loads see Section 18.1.1 for design interface information
L	=	Live Load Light Rail Vehicle Maintenance Train Highway Loads Pedestrian Loads
I	=	Impact (Dynamic Vehicle Allowance) Including Rocking Effect
CF	=	Centrifugal Force Hunting Force (Lateral Load from Equipment – AREMA 15-1.3.9)
LF	=	Longitudinal Force from Live Load Highway Loads LRV Loads
E	=	Earth Pressure
B	=	Buoyancy
W	=	Wind Load on Structure (With Live Load and Without Live Load)
WL	=	Wind Load on Live Load Light Rail Vehicle Highway Loads
S	=	Snow Load
OF	=	Other Forces Rib Shortening Shrinkage Creep Temperature Settlement of Supports Derailment Rail Break Collision Load Rail Restraint

18.4.1.1 Dead Load (D)

The dead load shall be computed from the actual weight of the structure and its permanent fixtures, and allowances for future modifications (e.g. additional ballast on ballasted decks and overlays on structures carrying both LRT and roadway traffic).

The weights of specific materials shall be accordance with AASHTO and AREMA guidance.

Use 200 pounds per foot for the weight of running rails, guard rails, and track fasteners. (Note, rail weights are given in pounds per yard.)

18.4.1.2 Live Load (L)

Live load shall consist of any moving loads including the weight LRV's, maintenance trains, highway vehicles, persons, or other moving objects, and loads due to maintenance operations. Accounting for the weight of stored materials for construction or maintenance is the responsibility of the construction or maintenance organization.

LRV design load shall be as prescribed in Figure 18-1 and as noted herein. Figure 18-1 is a schematic diagram that depicts the position and load of each LRV axle. In all cases, the combination of train lengths used for structural design shall be the one that produces the most severe conditions on the element being designed. An LRV train may consist of one, two, or three cars.

For loading cases considering fatigue loads from LRV's use 75% of the AW4 design vehicle.

Maintenance Train design load for LRT structures shall be as prescribed in Figure 18-1 and as noted herein. Figure 18-1 is a schematic diagram that depicts the position and load of each maintenance vehicle axle. Use the load factors prescribed for LRV loading for maintenance train loading.

Highway live loads for the design of new structures shall be HL-93. For existing structures carrying both Highway and LRT loads use HS-25.

For fatigue due to highway loading, use 75% of the HS-20 design truck.

Pedestrian live loads shall be a uniform load of 125 psf for station platforms, pedestrian ramps, and mezzanines.

Pedestrian areas on bridge shall be design for pedestrian loads as specified in the AASHTO Guide Specification for Pedestrian Bridges, Article 1.2.1 for Load Factor Design cases (rating of existing structures). This load is 65 psf for the design of main members when the contributory area is in excess of 850 sq ft. Use a load of 85 psf for the design of secondary members.

Use the pedestrian load as specified in the AASHTO LRFD Bridge Design Specification for the design of new bridges.

Service walkways and emergency walkways shall be designed for a uniform load of 85 psf.

Stairways shall be designed for a uniform load of 100 psf or a concentrated load of 300 pounds at each stair tread applied to produce a maximum stress condition, whichever produces the greater stress.

Railings shall be designed in accordance with the provisions stipulated by AASHTO LRFD 4th ed. Article 13 – Railings.

Structures shall be designed for foreseeable loads resulting from the method and route to be used for the installation and subsequent removal and replacement of the planned equipment.

18.4.1.3 Dynamic, Vibratory and Impact Due to LRVs Loading (I/IM)

The standard structural loading shall be increased for dynamic, vibratory, and impact effects for those structures, or parts thereof as follows:

- Superstructures, including steel or concrete supporting columns, steel towers, legs of rigid frames, and generally those portions of the structure which extend down to the main foundation; and
- That portion of concrete or steel piles above the ground line, when they are rigidly connected to the superstructure, as in rigid frames and continuous structures.

Items to which dynamic, vibratory, and impact does not apply are as follows:

- Abutments, retaining walls, wall-type piers, and piles, except those described above;
- Foundations and footings;
- Service walks; and
- Culverts and other buried structures having a cover of 3 ft. or more.

The vertical impact force shall be determined by the provisions of Article 3.8.2 – Impact Formula of AASHTO 17th Ed. The impact factor shall be applied to the standard LRV loading (Figure 18-1). The provisions for Rocking Effect forces as described by AREMA Article 15-1.3.5.d. shall be applied to individual members subject to the load. Note that this is not an increase in the total gravity load of the LRV or Maintenance Train.

18.4.1.4 Centrifugal Force (CF)

Structures that carry LRV on curves shall be designed for a centrifugal force per AREMA 15-1.3.6, except that the force shall be applied at a height of 6 feet.

18.4.1.4.1 Hunting Force (CF)

Provisions shall be made for a transverse horizontal hunting force equal to 25 percent of the standard LRV center truck loading (Figure 18-1) without impact. This force shall be applied as concentrated loads at the axle locations, acting in either direction transverse to the track through a point at the top of the low rail. Use the provisions of AREMA 15-1.3.9.b, to determine which members to apply this force to. Do not apply

this force to concrete decks, which have high stiffness in the horizontal direction. Apply the Hunting Force for the design of bearings.

18.4.1.5 Longitudinal Force (LF)

The structures subject to LRV loading shall be designed for longitudinal forces listed herein.

18.4.1.5.1 Acceleration and Deceleration (LF/BR)

Provision shall be made for the longitudinal force (LF) due to train acceleration and deceleration. The magnitude of the longitudinal force shall be computed as follows:

$$LF = 0.046 * W * A$$

Where W = vehicle weight (Figure 18-1)
 A = vehicle acceleration or deceleration rate in mph/sec

This force shall be applied to the rails and supporting structure as uniformly distributed load over the length of the train in a horizontal plane at the *top of low rail*. Consideration shall be given to various combinations of acceleration and deceleration forces where more than one track is carried by the structure. The vehicle acceleration rate may be taken as 3 miles per hour per second in accordance with the vehicle performance requirements of Section 8.6.1. The emergency braking rate may be taken as 6.5 miles per hour per second in accordance with the vehicle performance requirements of Section 8.6.3. The emergency braking rates apply to the AW3 vehicle – weight equal to 143,000 pounds - for determining the maximum deceleration forces. (Note to designers, LRV emergency brakes utilize an electric magnet clamping brake shoe, so the coefficient of friction for braking greatly exceeds steel on steel friction.)

Designers shall account for the type of rail fixation in considering how the longitudinal forces are applied to the bridge.

18.4.1.6 Friction or Shear Resistance at Expansion Bearings (F/TU)

Bridge structures shall be designed to accommodate forces and movements due temperature, volume change and friction or shear resistance at fixed and expansion bearings. The designer shall prepare a rational analysis of the entire structure that accounts for relative stiffness of all substructure elements and the friction or shear resistance of the bearings. The forces between the superstructure and the substructure shall be resolved into the longitudinal and transverse forces and movements with the forces and movements in all directions being accounted for. The Mn/DOT LRFD Bridge Design Manual provides guidance preparing a rational analysis. See pages 3-9 and 3-10.

18.4.1.7 Earth Pressure (E/EH, ES and LS)

All substructure elements shall be proportioned to withstand earth pressure as determined by geotechnical analysis of the in situ soils and the specified backfill materials..

In general, the following guidelines shall be adhered to:

- Structures that retain earth and are able to displace sufficiently to develop an active earth failure, shall be designed for active earth pressure due to earth abutting against the structure and load surcharges imposed on abutting earth. When displacement is limited or prevented, higher earth pressures, approximating at-rest pressures, will exist and shall be considered in design. Consideration shall also be given to multi-layered effects where substantial differences in soil properties occur over the depth of the structures;
- The design of spread footings soil shall utilize the Meyerhof distribution for the foundation design, but utilize a triangular distribution for reinforced concrete design of the footing.
- Live loads and dead loads from adjacent building foundations shall be considered in computing horizontal pressures;
- Passive earth pressure acting against the front face of a wall or abutment shall be neglected when computing the factors of safety for sliding or overturning; and
- The design of retaining walls, foundation walls, and abutments subject LRV loading shall be designed using the Trial Wedge Method of Earth Pressure Computation in accordance with AREMA Chapter 8, Commentary 5.3.2. II. Base the surcharge amount on the combination of axels that affect the wall based on the wall height and the distance of the track from the wall. In any location where roadway traffic can approach the top of the wall, the wall shall be designed for a minimum of the surcharge load specified in AASHTO LRFD 4th Edition, Section 3.11.6.4, Live Load Surcharge. Where transition slab are used to support the track, and the length of the slab is equal to or greater than the height of the abutment, no live load surcharge from the LRV needs to be applied to the abutment.

18.4.1.8 Buoyancy (B)

Structures shall be designed for a buoyancy force as applicable.

18.4.1.9 Wind Load on Structure (W/WS)

All existing bridges shall be rated for wind load on structure as per AASHTO 17th Ed, 3.15, Wind Loads. New bridges shall be designed for wind load on structures in accordance with AASHTO LRFD, 4th Edition 3.8, Wind Load. Include Wind Overturning Forces in the analysis in accordance with AASHTO 3.15.3 (17th Ed.) and Wind Vertical Pressure in accordance with AASHTO LRFD 3.8.2 (4th Ed.).

18.4.1.10 Wind Load on Live Load (WL)

The structures subject to LRV loading shall be designed for a wind load of 225 plf that is applied horizontally to the LRV. The load shall be applied 6 feet above the top of rail in a direction perpendicular to the centerline of track. The load on LRV's shall be limited to the length of two, 3 car trains (564 feet). For bridges longer than 564 feet, that also carry highway traffic, apply AASHTO Wind on Live Load Forces (3.15.1.2)

18.4.1.11 Earthquake Loads (EQ)

Subject to the Designers discretion, earthquake analysis will not be considered to have significant impact on any of the load cases and does not need to be considered for design.

18.4.1.12 Other Loads (OF)

18.4.1.12.1 Snow Load (OF)

Structures shall be designed for snow loads in combination with live loads where there is a possibility that normal maintenance activities do not clear accumulations of snow. The snow load used shall be applied in accordance with the Minnesota State building Code, Article 1303.1700, which specifies a ground snow load of 50 psf, and the International Building Code (IBC) Article 1608. For special situations, such as the Washington Avenue Bridge, consider drifting snow, in accordance with IBC Figure 1608.1(4), but note that the pedestrian deck on the Washington Avenue Bridge is cleared of snow during the winter in accordance with Agreement No's. 53326 and 53189 between the University of Minnesota and the Minnesota Department of Transportation.

18.4.1.12.2 Temperature (OF)

Provisions shall be made to design the LRT structures for stresses or movements resulting from temperature variations. The expected temperature rise and fall shall be taken as follows:

- Concrete
 - Temperature rise 35°F
 - Temperature fall 45°F

- Steel
 - Temperature rise 60°F
 - Temperature fall 90°F

- Rail (Ballasted Track and Direct Fixation Track)
 - Temperature rise 30°F
 - Temperature fall 120°F

Thermal forces that develop due to the restraint of continuous welded rail shall be considered as a temperature load. These forces shall be applied in a horizontal plane at the base of the high rail. The temperature range, and the magnitude and direction of the forces shall be determined by the Designer. The Designer should realize that ballasted and direct fixation track is generally “de-stressed” to a neutral temperature of a minimum of 90 degrees to assure a rail failure occurs as a break (which can be detected by the signal system) rather than as a buckle (which would likely result in a derailment). Embedded track is not “de-stressed”. Rail fasteners can be selected based on the desired amount of longitudinal restraint, and rail expansion joints can be placed based on the movements that must be accommodated to control rail forces. The design decisions affecting the behavior of the rail/structure interaction are beyond the scope of these design criteria.

18.4.1.12.3 Derailment (OF)

The superstructures for LRT aerial structures shall be designed for a vertical derailment load caused by a misdirected LRV, that is oriented with its longitudinal axis parallel to the track, but is transversely positioned a minimum of 1 foot 6 inches to a maximum of 3 feet from the centerline of the track. (See AREMA 15-1.3.10.b for the general configuration of this stability check.)

The derailment load shall be equivalent to a standard light rail transit vehicle axle load, plus an impact factor of 100 percent. For the derailment condition, a derailment load from two adjacent axles (one truck) shall be simultaneously applied to the deck. The load from the remaining light rail vehicle axles shall be applied through the rail using a normal impact factor. The derailment load axles should be selected such that they generate the critical loading condition for the structure. Do not apply the 100 percent impact factor to structures with embedded tracks.

When checking any component of superstructure or substructure that supports two or more tracks, only one train on one track shall be considered to have derailed, the other track(s) being either unloaded or loaded with a stationary train, whichever condition controls structural stability or design of the element under consideration.

For prestressed concrete members, the steel stress shall not exceed 85 percent of the ultimate tensile strength ($0.85 f_s$) and the concrete stress shall not exceed 60 percent of the 28-day compressive strength ($0.60 f'_c$). For load factor design, or load and resistance factor design, the live load factor may be reduced to 1.1. (Extreme Event)

18.4.1.12.4 Rail Break (OF)

Structures shall be designed to accommodate the temporary loads associated with rail replacement. In addition, the structures shall be capable of adequately

maintaining a broken rail with not more than a 4-inch gap at any one rail supported by the structure.

18.4.1.12.5 Rail Restraint (OF)

Whenever a continuous welded rail is terminated, provisions must be made to control the longitudinal forces. The designer shall determine the magnitude, directions, and point of application of the forces.

Termination, as used in the above paragraph, means absolute termination. The placement of a turnout or crossover between ends of continuous welded rail does not necessarily result in absolute termination of the rail. The continuous welded rail is not considered to be terminated if some means is provided, under the turnout or crossover, to transmit the above force from the end of one rail to the end of the other.

18.4.1.13 Transit Vehicle Load Distribution

Live load is to be distributed using the provisions stipulated by AREMA Chapter 8 Concrete Structures and Foundations and Chapter 15 Steel Structures.

18.4.1.14 Load Combinations

Use load combinations based on AASHTO LRFD Bridge Design Specifications, Section 3.4. The LRV and Maintenance Train Loads fit the criteria of Owner Specified Special Vehicles, suitable for the use of the Strength II condition (AASHTO 3.6.1.5). The live load to dead load ratios from LRT loadings for a given span length are much closer to the ratios for the AASHTO code than for the AREMA Manual.

18.4.1.15 Multiple Presence Factor

Note, Mn/DOT limits the Multiple Presence Factor for LRFD design when checking deflections due to three or more lanes of load to a minimum of 0.85. (Mn/DOT LRFD Bridge Design Manual 3.4.2)

18.4.2 Buildings and Non-Transportation Structures

The following loads and forces shall be considered when designing structures:

D	=	Dead Load
		System Wide Equipment Loads
L	=	Live Load
		Pedestrian Live Loads
		Miscellaneous Live Loads
E	=	Earth Pressure
B	=	Buoyancy
W	=	Wind Load on Structure

EQ = Earthquake
S = Snow Load

Section 9.1.5 contains specific additional guidance on loads used for the design of maintenance facilities.

18.4.2.1 Dead Load (D)

The dead loads consist of the actual weight of the structure including but not limited to walls, floors, partitions, roofs, electrification, safety walks, pipes, conduits, cables, utilities, services, and all other permanent construction fixtures.

18.4.2.2 Live Load (L)

Live load shall consist of any non-permanent loads including the weight of machinery, equipment, stored materials, persons, or other moving objects, construction loads, and loads due to maintenance of operations.

Pedestrian live loads shall be a uniform load of 125 psf for station platforms, pedestrian ramps, mezzanines.

Service walkways and emergency walkways shall be designed for a uniform load of 85 psf.

Stairways shall be designed for a uniform load of 100 psf or a concentrated load of 300 pounds at each stair tread applied to produce a maximum stress condition, whichever produces the greater stress.

Floors and all other areas not specified herein shall be designed for a uniform load of 150 psf or a concentrated load of 2000 pounds acting in an area 3 inch square applied to produce a maximum stress condition, whichever produces the greater stress.

Equipment rooms and storage spaces shall be designed for equipment loads or a uniform load of 250 psf, whichever produces the greater stress.

Aerial structures shall be designed for all loads resulting from the method and route to be used for the installation and subsequent removal and replacement of the various items of equipment.

18.4.2.3 Earth Pressure (E)

All substructure elements shall be proportioned to withstand earth pressure as stipulated by the Contractors geotechnical engineer.

In general, the following guidelines shall be adhered to:

- Structures that retain earth and are able to displace sufficiently to develop an active earth failure, shall be designed for active earth pressure due to earth

abutting against the structure and load surcharges imposed on abutting earth. When displacement is limited or prevented, at rest earth pressures will exist and shall be considered in design. Consideration shall also be given to multi-layered effects where substantial differences in soil properties occur over the depth of the structures;

- Live loads and dead loads from adjacent building foundations shall be considered in computing horizontal pressures;
- Passive earth pressure acting against the front face of a wall shall be neglected when computing the factors of safety for sliding or overturning; and
- LRV loading may be assumed as a uniform surcharge load equal to two additional feet of earth.

18.4.2.4 Buoyancy (B)

Structures shall be designed for a buoyancy force as applicable.

18.4.2.5 Wind Load on Structure (W)

All structures shall be designed for wind as per the Minnesota State Building Code.

18.4.2.6 Earthquake Loads (EQ)

Subject to the Designers discretion, earthquake analysis will not be considered to have significant impact on any of the load cases and does not need to be considered for design.

18.4.2.7 Snow Load (S)

All structures shall be designed for snow loads as per Minnesota State Building Code.

18.5 SPECIAL REQUIREMENTS FOR TRANSPORTATION STRUCTURES

18.5.1.1 Bridge Geometry

18.5.1.2 Bridge Type

18.5.1.3 Bridge Inspection Access

All bridge superstructures, joints and bearings shall be made accessible for long term inspection. Open framed superstructures shall be made accessible with walkways, ladders, or by providing access for an under-bridge inspection vehicle. Box girders shall be made available for interior inspection, provide a hinged metal door and padlock per Mn/DOT Bridge Details, drawing B942. The door shall swing into the box girder or away from traffic. Provide a method of ladder support off of the roadway where required for inspection access.

18.5.1.4 Bridge Components

Bridge components shall be designed and constructed to perform in a harsh and corrosive environment for at least 75 years with minimal maintenance.

Cover for coated reinforcing bars shall conform to AREMA. Where uncoated black reinforcing bars are used, the bars shall be placed with one additional inch of cover in all locations exposed to the atmosphere or earth.

18.5.1.4.1 Railing and Fencing

Design and construct bridge parapets, ornamental metal railing, and chain link fencing that reflect the Mn/DOT Standard Details. Ornamental railings shall be constructed of structural steel, and minimum steel thickness for railing members is 3/16". All railposts, railing vertical members, and concrete posts shall be set vertical, not perpendicular to grade. Railings shall be fully seal welded against water intrusion, including points of member intersection, and weep holes shall be provided at low points in members at splice locations. Railings shall be detailed to allow for adequate paint coverage and adhesion, particularly at points of member intersection. Drilled anchors for metal railing and fencing shall be chemical adhesive type anchors and the installation shall be field tested with proof loads on at least three anchors per application in accordance with the Construction Specifications. Anchorages shall be per detail Mn/DOT Bridge Details, drawing B905.

18.5.1.4.2 Bridge Decks

The decks for bridges shall be designed so as to prevent surface drainage from running off the edge of the deck, or where embedded track is used, from crossing the rail and rail boot. Drainage shall preferably be collected at the ends of the bridge. When intermediate drainage is needed, drains, conduit, and downspouts shall be galvanized structural steel, and shall be hidden from view. Downspouts that allow free falling water will not be allowed.

Design slabs for box girder bridges as follows:

- The slab shall be designed with consideration of two dimensional effects such as outward thrust due to sloping webs, and differential deflection and torsional rotation of adjacent girders; and
- Box girder webs shall preferably be positioned as close as possible to LRT rails. Subject to the Designer, transverse post-tensioning may not be required when rails are near a box girder web.

Provide deck joints as follows:

- Bridges shall incorporate as few expansion joints as possible. When joints are required they shall be located at supports:

-
- Construction joints in bridge decks shall be avoided as much as possible. The location of such transverse construction joints, the sequence of pours, and the direction in which the pours will be placed shall be indicated on the construction documents. Immediately prior to placing concrete against a construction joint in the bridge slab, the surface of the in place concrete shall be coated with an approved bonding agent or grout; and
 - Strip seal expansion joints per Mn/DOT Bridge Standard Detail Drawings 5-397.627 and 5-397.630 are preferred.

18.5.1.4.3 Bridge Girders

Paint all new steel for girders other than bearings. Inside surfaces of steel box girders shall be prime painted only, intermediate and top coats are not required.

The design of girders and diaphragms shall provide for accessibility and future replacement of bearings.

The deflection due to LRV live load plus impact shall be limited to span length / 1000. The maintenance vehicle is exempt from this requirement. Composite steel girder section properties for deflection computation shall in the negative moment region consist of the steel girder alone, and in the positive moment region between points of dead load contraflexure the steel box girder acting compositely with the concrete deck and nothing else. The modulus of elasticity for concrete girders and decks shall be derived from the design strength of the concrete. The deflection shall be determined at the most critical location within the span at the point of a Light Rail Vehicle wheel and including torsional rotation.

Exterior (fascia) webs shall be aligned throughout the bridge length.

Provide screened weep holes at low points.

Design of steel girders shall be as follows:

- Fracture critical members include bottom flanges and bottom half of webs of through girders, and tension flanges and tension half of webs for single and double box girder systems;
- Minimum web thickness is 1/2”;
- Bottom flanges of steel box girders shall be constant width if not haunched, and where haunched will vary in width such that webs are in alignment and have a constant slope. Flange plates shall be furnished in available mill lengths with a minimum number of splices. Minimum flange width is 14 inches and minimum thickness is 3/4 inches;
- Shear studs shall not be shop welded on splice plates. Shear connectors shall penetrate at least one inch above the bottom mat of reinforcement and shall be not less than three inches from the top of the slab in their final position;
- Cover plates, pins and hangers, and intermittent welds are not allowed;

-
- Shop connections shall be welded unless otherwise shown on the contract drawings. Field connections shall be bolted slip-critical connections with high strength bolts unless otherwise shown on the contract drawings;
 - Maximum variation from flatness for fascia beam webs shall be one half the limit given in the "ANSI/AASHTO/AWS D1.5, Bridge Welding Code", Section 9.23; and

Design of concrete girders shall be as follows:

- As specified by AREMA 8-17.16.2.2, prestressed concrete shall remain in compression at all times under service loads.

18.5.1.4.4 Bearings

Bearings shall be corrosion resistant. Design and location of bearings shall provide for accessibility and future replacement. Elastomeric bearings conforming to Mn/DOT Bridge Detail drawings B310 through B316, are preferred. If the Contractor elects to use rocker bearings, they shall be in accordance with Mn/DOT Bridge Detail drawings B341 and B342. Consideration shall be given to all longitudinal and transverse forces and movements.

18.5.1.4.5 Substructures

The minimum thickness for substructure components shall be 18 inches.

Piers shall be as follows:

Abutments shall be as follows:

- Abutments shall be cast-in-place concrete. The spacing of vertical construction joints shall not exceed 32 feet; and
- Install an abutment drainage system per Mn/DOT Bridge Details B910.

18.5.1.4.6 Special Surface Finish for Concrete

Provide Special Surface Finish for visible surfaces of new or existing concrete for bridges build or modified for LRT, following the requirements of the MN/DOT LRFD Bridge Design Manual, Section 5.6.

18.5.1.4.7 Transition Slabs

Provide a transition slab at each end of each new or rehabilitated bridge under each track alignment. The transition slab shall be supported by a paving bracket or corbel at the abutment. Provide for expansion and contraction at transition pavement interface where required. See Section 3.4.19 for requirements. Reinforcement shall conform to corrosion control requirements specified in Section 14.

18.5.2 Retaining Walls

The criteria contained herein shall apply to permanent wall structures. Temporary retaining structures are not covered by these specifications and the Contractor will have sole responsibility for the type, material, performance, and safety of any temporary structures.

Retaining wall layout shall address slope maintenance above and below the wall. Provide returns into the retained fill or cut at retaining wall ends where possible. Design and construction shall consider surface and subsurface drainage. A system shall be provided to intercept or prevent surface water from entering behind walls, and to drain subsurface water that does infiltrate behind walls. A chain link fence or pedestrian railing shall be provided at the top of walls where needed for public safety.

18.5.2.1 Retaining Wall Type

Proprietary wall systems will be considered in these cases only when comprised of wet cast air entrained concrete conforming to the Construction Specifications, provided with adequate frost protection, and tie back systems are designed for a 75 year design life. Cover for coated reinforcing bars in retaining walls shall conform to the Mn/DOT requirements. Where uncoated black reinforcing bars are used, the bars shall be placed with one additional inch of cover in all locations exposed to the atmosphere or earth, and the wall strength shall be designed accordingly.

18.5.2.1.1 Mechanically Stabilized Earth (MSE) Retaining Walls

If a fence is required along the top of the wall, it shall be located behind the wall, supported on concrete footings. The design of the wall and the location of footings shall take into account overturning forces applied to the fence. The geogrid or soil reinforcement shall be designed and reinforced around the openings for footings.

Utilities shall be located outside the construction limits of the retaining wall. Exceptions will be allowed with approval from the CCPO and the utility owner. Any utilities needing to be located within the construction limits shall be installed as the wall is being constructed. Once the geotextile layers are installed, neither the geotextile nor the utility shall be disturbed at any time.

18.5.3 Noise Walls

Noise walls shall be designed in accordance with the *AASHTO Guide Specifications for Structural Design of Sound Barriers (1989)*.

18.5.4 Embankments and Earth Slopes

Embankments and earth slopes shall be no steeper than 2 horizontal to 1 vertical. Slopes within a clear zone shall meet the requirements of the affected roadway.

18.6 SPECIAL REQUIREMENTS FOR BUILDINGS AND OTHER NON-TRANSPORTATION STRUCTURES

18.7 DETAILING AND PLAN REQUIREMENTS

- The loading criteria to which structures are designed shall appear on the structural drawings. When required by design conditions, concrete placing sequence shall be indicated on the plans.

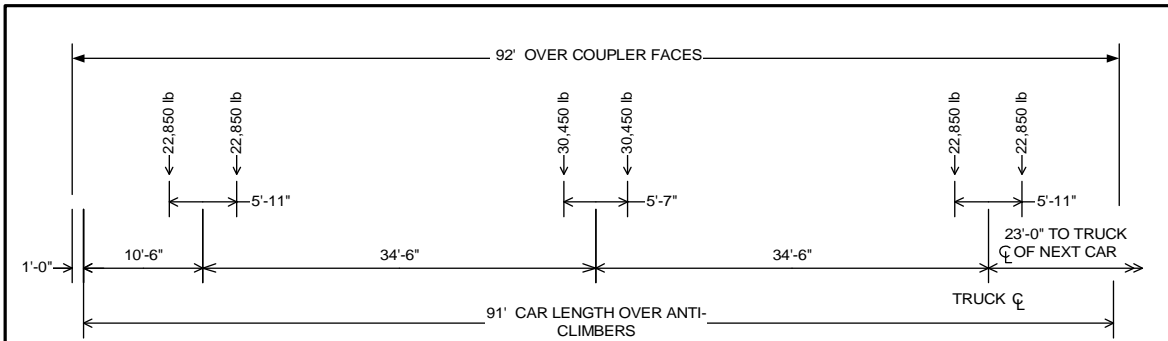

Light Rail Vehicle Loading Diagram

Notes:

- 1.) The LRT Train shall consist of either one, two or three cars, which ever produces the maximum load for the element under consideration.
- 2.) Axle load in pounds.
- 3.) Loading diagram represents maximum load at each truck in accordance with Figure 8-2.

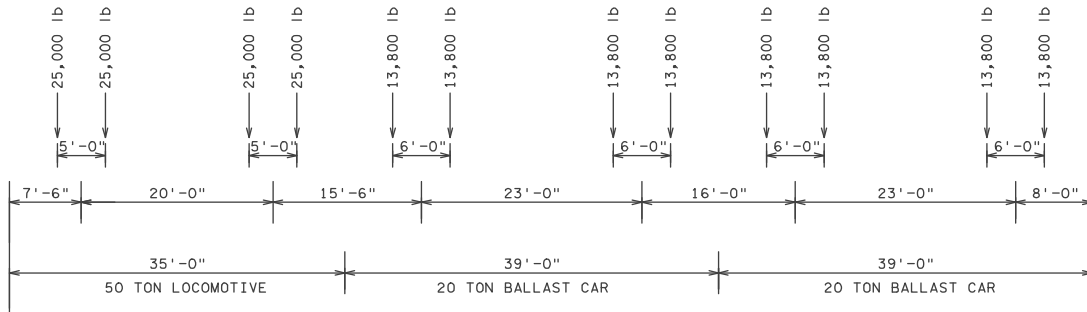

Maintenance Train Loading Diagram

Notes:

- 1.) The maintenance train shall consist of one locomotive and one, two, three, or four ballast cars; whichever produces the maximum load for the element under consideration.
- 2.) Axle load in pounds.
- 3.) Weight of empty ballast car is 15,000 pounds.

CENTRAL CORRIDOR LRT		FIGURE 18-1
DESIGN CRITERIA	STRUCTURE LOADING DIAGRAM	

Central Corridor LRT Design Criteria

Appendix A

Low Floor Vehicle Dynamic Clearance Program – Horizontal Offsets and Displacements

LOW FLOOR VEHICLE DYNAMIC ENVELOPE CLEARANCE PROGRAM - HORIZONTAL OFFSETS & DISPLACEMENTS

Agency Name:	Met Council
City:	MINNEAPOLIS / St Paul
State:	MINNESOTA

LFLRV Type:	DOUBLE ARTICULATED
LFLRV Manufacturer:	UNKNOWN AT THIS POINT
Pantograph Type:	UNKNOWN AT THIS POINT

File Name:	MIN-S.XLS
Revision By:	SCA
Revision Date:	02/22/99

DATA INPUT

End Truck Axle Spacing:	70.875	in
Center Truck Axle Spacing:	70.875	in
L1 - Pivot Centers Length:	352.000	in
L1A - Articulation Centers	124.000	in
L2 - Body Corner Length:	60.750	in
L3 - Front End Length:	114.000	in
L4 - Mirror Length:	97.000	in
L5 - Roof Equipment Length:	78.750	in
L6 - Roof Shroud	60.750	in
W2 - Body Corner Width:	105.000	in
W3 - Front End Width:	96.000	in
W4 - Mirror Width:	117.375	in
W5 - Roof Equipment Width:	76.750	in
W6 - Roof Shroud	96.500	in
Pantograph Sway (total)	3.000	in

LATERAL MOTION

Wheel wear:	0.300	in
Rail wear:	0.500	in
Rail gauge tolerance (half):	0.125	in
Wheel gauge tolerance (half):	0.031	in
Nominal sideplay (half):	0.375	in
Lateral suspension motion:	1.340	in
Total:	2.671	in

SKEW

Lateral Motion:	2.671	in
D2 - Body Corner Skew:	3.593	in
D3 - Front End Skew:	4.401	in
D4 - Mirror Skew:	4.143	in
D5 - Roof Equipment Skew:	3.866	in
D6 - Roof Shroud:	3.593	in

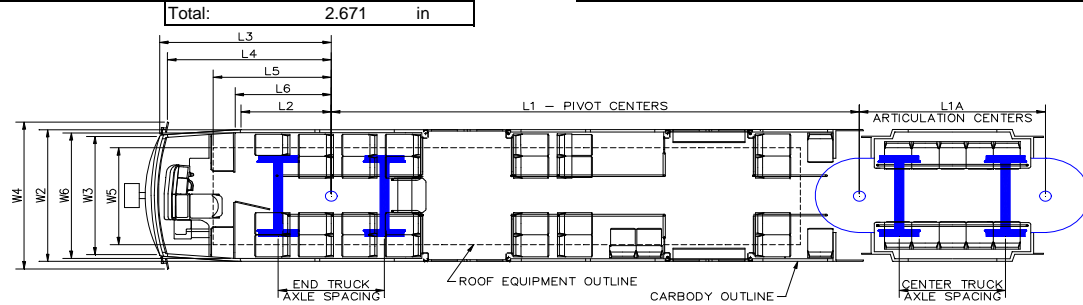

Radius: (ft)	Radius: (in)	d ₁ End Truck	d ₂ Center Truck	d ₃ Center Art. Joint	d Mid Body	D1	D1 ₅	D1 ₆	Body Corner		Front End		Mirror		Roof Equip		Roof Shroud	
									D2in	D2out	D3in	D3out	D4in	D4out	D5in	D5out	D6in	D6out
82	984	0.64	0.64	1.31	15.56	70.73	56.60	66.48	42.88	66.42	24.96	75.94	39.85	81.56	24.95	57.10	38.76	62.28
100	1200	0.52	0.52	1.08	12.72	67.89	53.77	63.64	45.47	64.77	30.12	72.04	44.26	78.52	28.22	54.62	41.31	60.59
150	1800	0.35	0.35	0.72	8.46	63.63	49.50	59.38	49.23	62.09	37.78	65.83	50.75	73.62	33.06	50.69	45.02	57.87
200	2400	0.26	0.26	0.54	6.34	61.51	47.38	57.26	51.03	60.67	41.54	62.59	53.88	71.05	35.42	48.65	46.80	56.44
300	3600	0.17	0.17	0.36	4.22	59.39	45.27	55.14	52.77	59.20	45.23	59.28	56.94	68.39	37.73	46.56	48.53	54.96
400	4800	0.13	0.13	0.27	3.16	58.34	44.21	54.09	53.62	58.44	47.05	57.59	58.45	67.03	38.88	45.50	49.38	54.20
500	6000	0.10	0.10	0.22	2.53	57.70	43.58	53.45	54.12	57.98	48.13	56.56	59.34	66.21	39.56	44.86	49.88	53.74
600	7200	0.09	0.09	0.18	2.11	57.28	43.16	53.03	54.46	57.67	48.85	55.88	59.93	65.65	40.01	44.43	50.21	53.43
700	8400	0.07	0.07	0.15	1.81	56.98	42.85	52.73	54.70	57.45	49.36	55.39	60.35	65.26	40.33	44.12	50.45	53.20
800	9600	0.07	0.07	0.13	1.58	56.75	42.63	52.50	54.87	57.28	49.74	55.02	60.66	64.96	40.57	43.88	50.62	53.03
900	10800	0.06	0.06	0.12	1.41	56.58	42.45	52.33	55.01	57.15	50.04	54.73	60.90	64.72	40.76	43.70	50.76	52.90
1000	12000	0.05	0.05	0.11	1.27	56.44	42.31	52.19	55.12	57.05	50.28	54.50	61.10	64.53	40.91	43.56	50.87	52.80
1200	14400	0.04	0.04	0.09	1.05	56.23	42.10	51.98	55.28	56.89	50.63	54.15	61.39	64.25	41.13	43.34	51.03	52.64
1500	18000	0.03	0.03	0.07	0.84	56.01	41.89	51.76	55.45	56.73	50.99	53.80	61.68	63.97	41.35	43.12	51.20	52.48
2000	24000	0.03	0.03	0.05	0.63	55.80	41.68	51.55	55.61	56.57	51.34	53.45	61.97	63.69	41.58	42.90	51.36	52.32
5000	60000	0.01	0.01	0.02	0.25	55.42	41.30	51.17	55.90	56.29	51.98	52.82	62.49	63.17	41.98	42.51	51.65	52.04
10000	120000	0.01	0.01	0.01	0.13	55.30	41.17	51.05	56.00	56.19	52.19	52.61	62.66	63.00	42.11	42.37	51.75	51.94
50000	600000	0.00	0.00	0.00	0.03	55.20	41.07	50.95	56.07	56.11	52.36	52.44	62.80	62.86	42.21	42.27	51.82	51.86
Tangent	6.E+11	0.00	0.00	0.00	0.00	55.17	41.05	50.92	56.09	56.09	52.40	52.40	62.83	62.83	42.24	42.24	51.84	51.84

Radius: (ft)	Radius: (in)	MAXin	MAXout	MAXin Mirror	MAXout Mirror	MAXin Roof Equip	MAXout Roof Equip	MAXin Roof Shroud	MAXout Roof Shroud
82	984	-70.73	75.94	-70.73	81.56	-56.60	57.10	-66.48	62.28
100	1200	-67.89	72.04	-67.89	78.52	-53.77	54.62	-63.64	60.59
150	1800	-63.63	65.83	-63.63	73.62	-49.50	50.69	-59.38	57.87
200	2400	-61.51	62.59	-61.51	71.05	-47.38	48.65	-57.26	56.44
300	3600	-59.39	59.28	-59.39	68.39	-45.27	46.56	-55.14	54.96
400	4800	-58.34	58.44	-58.45	67.03	-44.21	45.50	-54.09	54.20
500	6000	-57.70	57.98	-59.34	66.21	-43.58	44.86	-53.45	53.74
600	7200	-57.28	57.67	-59.93	65.65	-43.16	44.43	-53.03	53.43
700	8400	-56.98	57.45	-60.35	65.26	-42.85	44.12	-52.73	53.20
800	9600	-56.75	57.28	-60.66	64.96	-42.63	43.88	-52.50	53.03
900	10800	-56.58	57.15	-60.90	64.72	-42.45	43.70	-52.33	52.90
1000	12000	-56.44	57.05	-61.10	64.53	-42.31	43.56	-52.19	52.80
1200	14400	-56.23	56.89	-61.39	64.25	-42.10	43.34	-51.98	52.64
1500	18000	-56.01	56.73	-61.68	63.97	-41.89	43.12	-51.76	52.48
2000	24000	-55.80	56.57	-61.97	63.69	-41.68	42.90	-51.55	52.32
5000	60000	-55.90	56.29	-62.49	63.17	-41.98	42.51	-51.65	52.04
10000	120000	-56.00	56.19	-62.66	63.00	-42.11	42.37	-51.75	51.94
50000	600000	-56.07	56.11	-62.80	62.86	-42.21	42.27	-51.82	51.86
Tangent	6.E+11	-56.09	56.09	-62.83	62.83	-42.24	42.24	-51.84	51.84

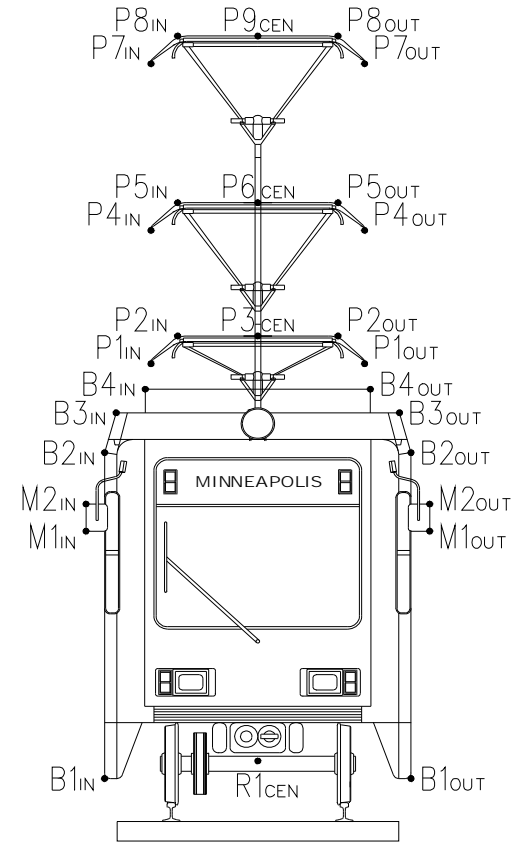

Track Gauge:	56.50	in
Rail Head Width:	2.72	in
Roll Angle:	4.00	Degrees
Mirror Roll Angle:	4.00	Degrees

SUPERELEVATION & CROSS LEVEL FOR EACH TABLE					
Table Number	Super Elevation	Cross Level	Table Number	Super Elevation	Cross Level
1	0.00	0.50	8	0.00	1.00
2	1.00	0.50	9	1.00	1.00
3	2.00	0.50	10	2.00	1.00
4	3.00	0.50	11	3.00	1.00
5	4.00	0.50	12	4.00	1.00
6	5.00	0.50	13	5.00	1.00
7	6.00	0.50	14	6.00	1.00

STATIC LFLRV ROLL CENTER

	X	Y
	in	in
R1	0.00	15.00

STATIC LFLRV BODY POINTS

	X	Y		X	Y
	in	in		in	in
B1 _{OUT}	52.50	8.66	B1 _{IN}	-52.50	8.66
B2 _{OUT}	52.50	126.00	B2 _{IN}	-52.50	126.00
B3 _{OUT}	48.25	140.35	B3 _{IN}	-48.25	140.35
B4 _{OUT}	38.38	148.82	B4 _{IN}	-38.38	148.82

STATIC LFLRV MIRROR POINTS

	X	Y		X	Y
	in	in		in	in
M1 _{OUT}	58.69	97.75	M1 _{IN}	-58.69	97.75
M2 _{OUT}	58.69	107.50	M2 _{IN}	-58.69	107.50

STATIC LFLRV PANTOGRAPH POINTS

	X	Y		X	Y
	in	in		in	in
P1 _{OUT}	39.00	146.00	P1 _{IN}	-39.00	146.00
P2 _{OUT}	24.00	156.00	P2 _{IN}	-24.00	156.00
P3 _{CEN}	0.00	156.00			
P4 _{OUT}	39.00	158.75	P4 _{IN}	-39.00	158.75
P5 _{OUT}	24.00	168.75	P5 _{IN}	-24.00	168.75
P6 _{CEN}	0.00	168.75			
P7 _{OUT}	39.00	258.00	P7 _{IN}	-39.00	258.00
P8 _{OUT}	24.00	268.00	P8 _{IN}	-24.00	268.00
P9 _{CEN}	0.00	268.00			

B# = LFLRV Body Points
M# = LFLRV Mirror Points
P# = LFLRV Pantograph Points
R# = LFLRV Roll Center Point

Central Corridor LRT Design Criteria

Appendix B

Vehicle Dynamic Envelope

Met Council PROPOSED LOW FLOOR LIGHT RAIL VEHICLE

TABLE 1A - VEHICLE DYNAMIC ENVELOPE - OUTSIDE OF CURVE

Cross Level Variation = 0.5 in
Superelevation = 0.0 in

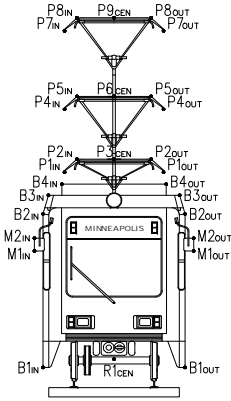

RADIUS FEET	R1 _{CEN}		B1 _{OUT}		M1 _{OUT}		M2 _{OUT}		B2 _{OUT}		B3 _{OUT}		B4 _{OUT}	
	X	Y	X	Y	X	Y	X	Y	X	Y	X	Y	X	Y
82	-0.13	15.25	76.35	4.32	87.98	92.66	88.74	112.05	84.58	130.01	72.06	143.99	67.57	151.66
100	-0.13	15.25	72.46	4.32	84.94	92.66	85.70	112.05	80.68	130.01	70.37	143.99	65.10	151.66
150	-0.13	15.25	66.25	4.32	80.04	92.66	80.80	112.05	74.47	130.01	67.65	143.99	61.17	151.66
200	-0.13	15.25	63.01	4.32	77.47	92.66	78.23	112.05	71.24	130.01	66.22	143.99	59.13	151.66
300	-0.13	15.25	59.70	4.32	74.81	92.66	75.57	112.05	67.92	130.01	64.74	143.99	57.04	151.66
400	-0.13	15.25	58.86	4.32	73.45	92.66	74.21	112.05	67.09	130.01	63.98	143.99	55.97	151.66
500	-0.13	15.25	58.40	4.32	72.63	92.66	73.39	112.05	66.63	130.01	63.52	143.99	55.33	151.66
600	-0.13	15.25	58.09	4.32	72.07	92.66	72.83	112.05	66.32	130.01	63.20	143.99	54.90	151.66
700	-0.13	15.25	57.87	4.32	71.67	92.66	72.43	112.05	66.10	130.01	62.98	143.99	54.59	151.66
800	-0.13	15.25	57.70	4.32	71.37	92.66	72.13	112.05	65.93	130.01	62.81	143.99	54.36	151.66
900	-0.13	15.25	57.57	4.32	71.14	92.66	71.90	112.05	65.80	130.01	62.68	143.99	54.17	151.66
1000	-0.13	15.25	57.47	4.32	70.95	92.66	71.71	112.05	65.69	130.01	62.58	143.99	54.03	151.66
1200	-0.13	15.25	57.31	4.32	70.67	92.66	71.43	112.05	65.53	130.01	62.42	143.99	53.81	151.66
1500	-0.13	15.25	57.15	4.32	70.39	92.66	71.15	112.05	65.38	130.01	62.26	143.99	53.59	151.66
2000	-0.13	15.25	56.99	4.32	70.10	92.66	70.87	112.05	65.22	130.01	62.10	143.99	53.37	151.66
5000	-0.13	15.25	56.70	4.32	69.59	92.66	70.35	112.05	64.93	130.01	61.81	143.99	52.98	151.66
10000	-0.13	15.25	56.61	4.32	69.42	92.66	70.18	112.05	64.83	130.01	61.72	143.99	52.85	151.66
50000	-0.13	15.25	56.53	4.32	69.28	92.66	70.04	112.05	64.76	130.01	61.64	143.99	52.74	151.66
Tangent	-0.13	15.25	56.51	4.32	69.25	92.66	70.01	112.05	64.74	130.01	61.62	143.99	52.71	151.66

NOTES:

Coordinates shown are in english units (###)

Maximum values for each radius are shown in Bold Italicized font

All coordinates shown are referenced from a point located at 1/2 track gauge and top of rail (0,0)

Superelevation is applied relative to top of low rail

Points R1_{CEN}, P3_{CEN}, P6_{CEN} and P9_{CEN} are not specific to either Outside or Inside of curve

B# = LFLRV Body Points

M# = LFLRV Mirror Points

P# = LFLRV Pantograph Points

R# = LFLRV Roll Center Point

File Name: MIN-S.XLS
Revision By: SCA
Revision Date: 02/22/99

RADIUS FEET	P3 _{CEN}		P1 _{OUT}		P2 _{OUT}		P4 _{OUT}		P5 _{OUT}		P7 _{OUT}		P8 _{OUT}	
	X	Y	X	Y	X	Y	X	Y	X	Y	X	Y	X	Y
82	-15.32	156.24	53.42	148.90	39.25	157.69	54.42	161.61	40.24	170.41	62.18	260.55	48.00	269.35
100	-15.32	156.24	53.42	148.90	39.25	157.69	54.42	161.61	40.24	170.41	62.18	260.55	48.00	269.35
150	-15.32	156.24	53.42	148.90	39.25	157.69	54.42	161.61	40.24	170.41	62.18	260.55	48.00	269.35
200	-15.32	156.24	53.42	148.90	39.25	157.69	54.42	161.61	40.24	170.41	62.18	260.55	48.00	269.35
300	-15.32	156.24	53.42	148.90	39.25	157.69	54.42	161.61	40.24	170.41	62.18	260.55	48.00	269.35
400	-15.32	156.24	53.42	148.90	39.25	157.69	54.42	161.61	40.24	170.41	62.18	260.55	48.00	269.35
500	-15.32	156.24	53.42	148.90	39.25	157.69	54.42	161.61	40.24	170.41	62.18	260.55	48.00	269.35
600	-15.32	156.24	53.42	148.90	39.25	157.69	54.42	161.61	40.24	170.41	62.18	260.55	48.00	269.35
700	-15.32	156.24	53.42	148.90	39.25	157.69	54.42	161.61	40.24	170.41	62.18	260.55	48.00	269.35
800	-15.32	156.24	53.42	148.90	39.25	157.69	54.42	161.61	40.24	170.41	62.18	260.55	48.00	269.35
900	-15.32	156.24	53.42	148.90	39.25	157.69	54.42	161.61	40.24	170.41	62.18	260.55	48.00	269.35
1000	-15.32	156.24	53.42	148.90	39.25	157.69	54.42	161.61	40.24	170.41	62.18	260.55	48.00	269.35
1200	-15.32	156.24	53.42	148.90	39.25	157.69	54.42	161.61	40.24	170.41	62.18	260.55	48.00	269.35
1500	-15.32	156.24	53.42	148.90	39.25	157.69	54.42	161.61	40.24	170.41	62.18	260.55	48.00	269.35
2000	-15.32	156.24	53.42	148.90	39.25	157.69	54.42	161.61	40.24	170.41	62.18	260.55	48.00	269.35
5000	-15.32	156.24	53.42	148.90	39.25	157.69	54.42	161.61	40.24	170.41	62.18	260.55	48.00	269.35
10000	-15.32	156.24	53.42	148.90	39.25	157.69	54.42	161.61	40.24	170.41	62.18	260.55	48.00	269.35
50000	-15.32	156.24	53.42	148.90	39.25	157.69	54.42	161.61	40.24	170.41	62.18	260.55	48.00	269.35
Tangent	-15.32	156.24	53.42	148.90	39.25	157.69	54.42	161.61	40.24	170.41	62.18	260.55	48.00	269.35

Met Council PROPOSED LOW FLOOR LIGHT RAIL VEHICLE

TABLE 1B - VEHICLE DYNAMIC ENVELOPE - INSIDE OF CURVE

Cross Level Variation = 0.5 in
Superelevation = 0.0 in

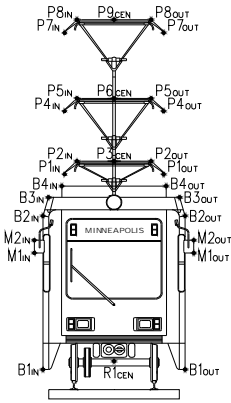

RADIUS FEET	P6 _{CEN}		B1 _{IN}		M1 _{IN}		M2 _{IN}		B2 _{IN}		B3 _{IN}		B4 _{IN}	
	X	Y	X	Y	X	Y	X	Y	X	Y	X	Y	X	Y
82	-16.32	168.99	-71.14	4.32	-77.14	92.66	-77.91	112.05	-79.37	130.01	-76.26	143.99	-67.07	151.66
100	-16.32	168.99	-68.31	4.32	-74.31	92.66	-75.07	112.05	-76.54	130.01	-73.42	143.99	-64.24	151.66
150	-16.32	168.99	-64.05	4.32	-70.04	92.66	-70.81	112.05	-72.27	130.01	-69.16	143.99	-59.97	151.66
200	-16.32	168.99	-61.92	4.32	-67.92	92.66	-68.69	112.05	-70.15	130.01	-67.04	143.99	-57.85	151.66
300	-16.32	168.99	-59.81	4.32	-65.81	92.66	-66.57	112.05	-68.04	130.01	-64.92	143.99	-55.74	151.66
400	-16.32	168.99	-58.75	4.32	-64.86	92.66	-65.62	112.05	-66.98	130.01	-63.87	143.99	-54.68	151.66
500	-16.32	168.99	-58.12	4.32	-65.75	92.66	-66.52	112.05	-66.35	130.01	-63.23	143.99	-54.05	151.66
600	-16.32	168.99	-57.70	4.32	-66.34	92.66	-67.11	112.05	-65.93	130.01	-62.81	143.99	-53.63	151.66
700	-16.32	168.99	-57.40	4.32	-66.76	92.66	-67.53	112.05	-65.62	130.01	-62.51	143.99	-53.33	151.66
800	-16.32	168.99	-57.17	4.32	-67.08	92.66	-67.84	112.05	-65.40	130.01	-62.28	143.99	-53.10	151.66
900	-16.32	168.99	-56.99	4.32	-67.32	92.66	-68.08	112.05	-65.22	130.01	-62.11	143.99	-52.92	151.66
1000	-16.32	168.99	-56.85	4.32	-67.52	92.66	-68.28	112.05	-65.08	130.01	-61.97	143.99	-52.78	151.66
1200	-16.32	168.99	-56.64	4.32	-67.81	92.66	-68.57	112.05	-64.87	130.01	-61.76	143.99	-52.57	151.66
1500	-16.32	168.99	-56.43	4.32	-68.10	92.66	-68.86	112.05	-64.66	130.01	-61.54	143.99	-52.36	151.66
2000	-16.32	168.99	-56.22	4.32	-68.39	92.66	-69.15	112.05	-64.45	130.01	-61.33	143.99	-52.15	151.66
5000	-16.32	168.99	-56.32	4.32	-68.90	92.66	-69.67	112.05	-64.54	130.01	-61.43	143.99	-52.45	151.66
10000	-16.32	168.99	-56.41	4.32	-69.08	92.66	-69.84	112.05	-64.64	130.01	-61.53	143.99	-52.58	151.66
50000	-16.32	168.99	-56.49	4.32	-69.21	92.66	-69.98	112.05	-64.72	130.01	-61.60	143.99	-52.69	151.66
Tangent	-16.32	168.99	-56.51	4.32	-69.25	92.66	-70.01	112.05	-64.74	130.01	-61.62	143.99	-52.71	151.66

NOTES:

Coordinates shown are in english units (mm)

Maximum values for each radius are shown in Bold Italicized font

All coordinates shown are referenced from a point located at 1/2 track gauge and top of rail (0,0)

Superelevation is applied relative to top of low rail

Points R1_{CEN}, P3_{CEN}, P6_{CEN} and P9_{CEN} are not specific to either Outside or Inside of curve

B# = LFLRV Body Points

M# = LFLRV Mirror Points

P# = LFLRV Pantograph Points

R# = LFLRV Roll Center Point

File Name: MIN-S.XLS

Revision By: SCA

Revision Date: 02/22/99

RADIUS FEET	P9 _{CEN}		P1 _{IN}		P2 _{IN}		P4 _{IN}		P5 _{IN}		P7 _{IN}		P8 _{IN}	
	X	Y	X	Y	X	Y	X	Y	X	Y	X	Y	X	Y
82	-24.08	268.24	-53.42	148.90	-39.25	157.69	-54.42	161.61	-40.24	170.41	-62.18	260.55	-48.00	269.35
100	-24.08	268.24	-53.42	148.90	-39.25	157.69	-54.42	161.61	-40.24	170.41	-62.18	260.55	-48.00	269.35
150	-24.08	268.24	-53.42	148.90	-39.25	157.69	-54.42	161.61	-40.24	170.41	-62.18	260.55	-48.00	269.35
200	-24.08	268.24	-53.42	148.90	-39.25	157.69	-54.42	161.61	-40.24	170.41	-62.18	260.55	-48.00	269.35
300	-24.08	268.24	-53.42	148.90	-39.25	157.69	-54.42	161.61	-40.24	170.41	-62.18	260.55	-48.00	269.35
400	-24.08	268.24	-53.42	148.90	-39.25	157.69	-54.42	161.61	-40.24	170.41	-62.18	260.55	-48.00	269.35
500	-24.08	268.24	-53.42	148.90	-39.25	157.69	-54.42	161.61	-40.24	170.41	-62.18	260.55	-48.00	269.35
600	-24.08	268.24	-53.42	148.90	-39.25	157.69	-54.42	161.61	-40.24	170.41	-62.18	260.55	-48.00	269.35
700	-24.08	268.24	-53.42	148.90	-39.25	157.69	-54.42	161.61	-40.24	170.41	-62.18	260.55	-48.00	269.35
800	-24.08	268.24	-53.42	148.90	-39.25	157.69	-54.42	161.61	-40.24	170.41	-62.18	260.55	-48.00	269.35
900	-24.08	268.24	-53.42	148.90	-39.25	157.69	-54.42	161.61	-40.24	170.41	-62.18	260.55	-48.00	269.35
1000	-24.08	268.24	-53.42	148.90	-39.25	157.69	-54.42	161.61	-40.24	170.41	-62.18	260.55	-48.00	269.35
1200	-24.08	268.24	-53.42	148.90	-39.25	157.69	-54.42	161.61	-40.24	170.41	-62.18	260.55	-48.00	269.35
1500	-24.08	268.24	-53.42	148.90	-39.25	157.69	-54.42	161.61	-40.24	170.41	-62.18	260.55	-48.00	269.35
2000	-24.08	268.24	-53.42	148.90	-39.25	157.69	-54.42	161.61	-40.24	170.41	-62.18	260.55	-48.00	269.35
5000	-24.08	268.24	-53.42	148.90	-39.25	157.69	-54.42	161.61	-40.24	170.41	-62.18	260.55	-48.00	269.35
10000	-24.08	268.24	-53.42	148.90	-39.25	157.69	-54.42	161.61	-40.24	170.41	-62.18	260.55	-48.00	269.35
50000	-24.08	268.24	-53.42	148.90	-39.25	157.69	-54.42	161.61	-40.24	170.41	-62.18	260.55	-48.00	269.35
Tangent	-24.08	268.24	-53.42	148.90	-39.25	157.69	-54.42	161.61	-40.24	170.41	-62.18	260.55	-48.00	269.35

Met Council PROPOSED LOW FLOOR LIGHT RAIL VEHICLE

TABLE 2A - VEHICLE DYNAMIC ENVELOPE - OUTSIDE OF CURVE

Cross Level Variation = 0.5 in
Superelevation = 1.0 in

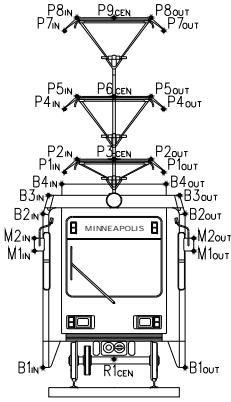

NOTES:

Coordinates shown are in english units (mm)

Maximum values for each radius are shown in Bold Italicized font

All coordinates shown are referenced from a point located at 1/2 track gauge and top of rail (0,0)

Superelevation is applied relative to top of low rail

Points R1_{CEN}, P3_{CEN}, P6_{CEN} and P9_{CEN} are not specific to either Outside or Inside of curve

B# = LFLRV Body Points

M# = LFLRV Mirror Points

P# = LFLRV Pantograph Points

R# = LFLRV Roll Center Point

File Name: MIN-S.XLS
Revision By: SCA
Revision Date: 02/22/99

RADIUS FEET	R1 _{CEN}		B1 _{OUT}		M1 _{OUT}		M2 _{OUT}		B2 _{OUT}		B3 _{OUT}		B4 _{OUT}	
	X	Y	X	Y	X	Y	X	Y	X	Y	X	Y	X	Y
82	-0.39	15.75	76.14	5.70	86.40	94.24	87.00	113.40	82.52	131.23	69.75	145.11	65.11	152.61
100	-0.39	15.75	72.25	5.70	83.36	94.24	83.96	113.40	78.62	131.23	68.06	145.11	62.63	152.61
150	-0.39	15.75	66.04	5.70	78.46	94.24	79.06	113.40	72.41	131.23	65.35	145.11	58.70	152.61
200	-0.39	15.75	62.80	5.70	75.89	94.24	76.49	113.40	69.18	131.23	63.91	145.11	56.66	152.61
300	-0.39	15.75	59.49	5.70	73.23	94.24	73.83	113.40	65.86	131.23	62.43	145.11	54.57	152.61
400	-0.39	15.75	58.65	5.70	71.87	94.24	72.47	113.40	65.03	131.23	61.67	145.11	53.51	152.61
500	-0.39	15.75	58.19	5.70	71.05	94.24	71.65	113.40	64.57	131.23	61.21	145.11	52.87	152.61
600	-0.39	15.75	57.88	5.70	70.49	94.24	71.09	113.40	64.26	131.23	60.90	145.11	52.44	152.61
700	-0.39	15.75	57.66	5.70	70.09	94.24	70.69	113.40	64.03	131.23	60.67	145.11	52.13	152.61
800	-0.39	15.75	57.49	5.70	69.79	94.24	70.39	113.40	63.87	131.23	60.51	145.11	51.89	152.61
900	-0.39	15.75	57.36	5.70	69.56	94.24	70.16	113.40	63.74	131.23	60.38	145.11	51.71	152.61
1000	-0.39	15.75	57.26	5.70	69.37	94.24	69.97	113.40	63.63	131.23	60.27	145.11	51.57	152.61
1200	-0.39	15.75	57.10	5.70	69.09	94.24	69.69	113.40	63.47	131.23	60.11	145.11	51.35	152.61
1500	-0.39	15.75	56.94	5.70	68.81	94.24	69.41	113.40	63.32	131.23	59.95	145.11	51.13	152.61
2000	-0.39	15.75	56.78	5.70	68.53	94.24	69.12	113.40	63.16	131.23	59.79	145.11	50.91	152.61
5000	-0.39	15.75	56.49	5.70	68.01	94.24	68.61	113.40	62.87	131.23	59.51	145.11	50.52	152.61
10000	-0.39	15.75	56.40	5.70	67.84	94.24	68.44	113.40	62.77	131.23	59.41	145.11	50.38	152.61
50000	-0.39	15.75	56.32	5.70	67.70	94.24	68.30	113.40	62.70	131.23	59.33	145.11	50.28	152.61
Tangent	-0.39	15.75	56.30	5.70	67.67	94.24	68.27	113.40	62.68	131.23	59.31	145.11	50.25	152.61

RADIUS FEET	P3 _{CEN}		P1 _{OUT}		P2 _{OUT}		P4 _{OUT}		P5 _{OUT}		P7 _{OUT}		P8 _{OUT}	
	X	Y	X	Y	X	Y	X	Y	X	Y	X	Y	X	Y
82	-17.95	156.74	51.01	149.86	36.65	158.39	51.79	162.55	37.43	171.08	57.88	261.35	43.52	269.88
100	-17.95	156.74	51.01	149.86	36.65	158.39	51.79	162.55	37.43	171.08	57.88	261.35	43.52	269.88
150	-17.95	156.74	51.01	149.86	36.65	158.39	51.79	162.55	37.43	171.08	57.88	261.35	43.52	269.88
200	-17.95	156.74	51.01	149.86	36.65	158.39	51.79	162.55	37.43	171.08	57.88	261.35	43.52	269.88
300	-17.95	156.74	51.01	149.86	36.65	158.39	51.79	162.55	37.43	171.08	57.88	261.35	43.52	269.88
400	-17.95	156.74	51.01	149.86	36.65	158.39	51.79	162.55	37.43	171.08	57.88	261.35	43.52	269.88
500	-17.95	156.74	51.01	149.86	36.65	158.39	51.79	162.55	37.43	171.08	57.88	261.35	43.52	269.88
600	-17.95	156.74	51.01	149.86	36.65	158.39	51.79	162.55	37.43	171.08	57.88	261.35	43.52	269.88
700	-17.95	156.74	51.01	149.86	36.65	158.39	51.79	162.55	37.43	171.08	57.88	261.35	43.52	269.88
800	-17.95	156.74	51.01	149.86	36.65	158.39	51.79	162.55	37.43	171.08	57.88	261.35	43.52	269.88
900	-17.95	156.74	51.01	149.86	36.65	158.39	51.79	162.55	37.43	171.08	57.88	261.35	43.52	269.88
1000	-17.95	156.74	51.01	149.86	36.65	158.39	51.79	162.55	37.43	171.08	57.88	261.35	43.52	269.88
1200	-17.95	156.74	51.01	149.86	36.65	158.39	51.79	162.55	37.43	171.08	57.88	261.35	43.52	269.88
1500	-17.95	156.74	51.01	149.86	36.65	158.39	51.79	162.55	37.43	171.08	57.88	261.35	43.52	269.88
2000	-17.95	156.74	51.01	149.86	36.65	158.39	51.79	162.55	37.43	171.08	57.88	261.35	43.52	269.88
5000	-17.95	156.74	51.01	149.86	36.65	158.39	51.79	162.55	37.43	171.08	57.88	261.35	43.52	269.88
10000	-17.95	156.74	51.01	149.86	36.65	158.39	51.79	162.55	37.43	171.08	57.88	261.35	43.52	269.88
50000	-17.95	156.74	51.01	149.86	36.65	158.39	51.79	162.55	37.43	171.08	57.88	261.35	43.52	269.88
Tangent	-17.95	156.74	51.01	149.86	36.65	158.39	51.79	162.55	37.43	171.08	57.88	261.35	43.52	269.88

Met Council PROPOSED LOW FLOOR LIGHT RAIL VEHICLE

TABLE 2B - VEHICLE DYNAMIC ENVELOPE - INSIDE OF CURVE

Cross Level Variation = 0.5 in
Superelevation = 1.0 in

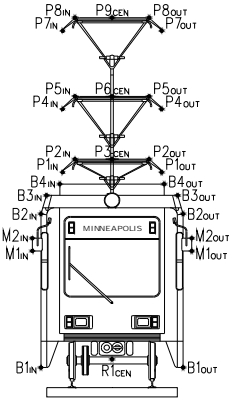

NOTES:

Coordinates shown are in english units (mm)

Maximum values for each radius are shown in Bold Italicized font

All coordinates shown are referenced from a point located at 1/2 track gauge and top of rail (0,0)

Superelevation is applied relative to top of low rail

Points R1_{CEN}, P3_{CEN}, P6_{CEN} and P9_{CEN} are not specific to either Outside or Inside of curve

B# = LFLRV Body Points

M# = LFLRV Mirror Points

P# = LFLRV Pantograph Points

R# = LFLRV Roll Center Point

File Name: MIN-S.XLS
Revision By: SCA
Revision Date: 02/22/99

RADIUS FEET	P6 _{CEN}		B1 _{IN}		M1 _{IN}		M2 _{IN}		B2 _{IN}		B3 _{IN}		B4 _{IN}	
	X	Y	X	Y	X	Y	X	Y	X	Y	X	Y	X	Y
82	-19.17	169.49	-71.35	3.95	-78.71	92.05	-79.64	111.67	-81.42	129.76	-78.56	143.82	-69.53	151.67
100	-19.17	169.49	-68.51	3.95	-75.88	92.05	-76.80	111.67	-78.59	129.76	-75.72	143.82	-66.70	151.67
150	-19.17	169.49	-64.25	3.95	-71.61	92.05	-72.54	111.67	-74.32	129.76	-71.46	143.82	-62.43	151.67
200	-19.17	169.49	-62.13	3.95	-69.49	92.05	-70.42	111.67	-72.20	129.76	-69.34	143.82	-60.31	151.67
300	-19.17	169.49	-60.01	3.95	-67.38	92.05	-68.30	111.67	-70.09	129.76	-67.22	143.82	-58.20	151.67
400	-19.17	169.49	-58.96	3.95	-66.43	92.05	-67.36	111.67	-69.03	129.76	-66.16	143.82	-57.14	151.67
500	-19.17	169.49	-58.32	3.95	-67.32	92.05	-68.25	111.67	-68.40	129.76	-65.53	143.82	-56.51	151.67
600	-19.17	169.49	-57.90	3.95	-67.91	92.05	-68.84	111.67	-67.98	129.76	-65.11	143.82	-56.08	151.67
700	-19.17	169.49	-57.60	3.95	-68.33	92.05	-69.26	111.67	-67.68	129.76	-64.81	143.82	-55.78	151.67
800	-19.17	169.49	-57.37	3.95	-68.65	92.05	-69.57	111.67	-67.45	129.76	-64.58	143.82	-55.56	151.67
900	-19.17	169.49	-57.20	3.95	-68.89	92.05	-69.81	111.67	-67.27	129.76	-64.41	143.82	-55.38	151.67
1000	-19.17	169.49	-57.06	3.95	-69.08	92.05	-70.01	111.67	-67.13	129.76	-64.27	143.82	-55.24	151.67
1200	-19.17	169.49	-56.84	3.95	-69.37	92.05	-70.30	111.67	-66.92	129.76	-64.05	143.82	-55.03	151.67
1500	-19.17	169.49	-56.63	3.95	-69.66	92.05	-70.59	111.67	-66.71	129.76	-63.84	143.82	-54.82	151.67
2000	-19.17	169.49	-56.42	3.95	-69.95	92.05	-70.88	111.67	-66.50	129.76	-63.63	143.82	-54.61	151.67
5000	-19.17	169.49	-56.52	3.95	-70.47	92.05	-71.40	111.67	-66.60	129.76	-63.73	143.82	-54.90	151.67
10000	-19.17	169.49	-56.62	3.95	-70.64	92.05	-71.57	111.67	-66.69	129.76	-63.83	143.82	-55.04	151.67
50000	-19.17	169.49	-56.69	3.95	-70.78	92.05	-71.71	111.67	-66.77	129.76	-63.90	143.82	-55.14	151.67
Tangent	-19.17	169.49	-56.71	3.95	-70.82	92.05	-71.74	111.67	-66.79	129.76	-63.92	143.82	-55.17	151.67

RADIUS FEET	P9 _{CEN}		P1 _{IN}		P2 _{IN}		P4 _{IN}		P5 _{IN}		P7 _{IN}		P8 _{IN}	
	X	Y	X	Y	X	Y	X	Y	X	Y	X	Y	X	Y
82	-28.59	268.74	-55.83	148.89	-41.85	157.96	-57.04	161.62	-43.06	170.68	-66.47	260.68	-52.49	269.75
100	-28.59	268.74	-55.83	148.89	-41.85	157.96	-57.04	161.62	-43.06	170.68	-66.47	260.68	-52.49	269.75
150	-28.59	268.74	-55.83	148.89	-41.85	157.96	-57.04	161.62	-43.06	170.68	-66.47	260.68	-52.49	269.75
200	-28.59	268.74	-55.83	148.89	-41.85	157.96	-57.04	161.62	-43.06	170.68	-66.47	260.68	-52.49	269.75
300	-28.59	268.74	-55.83	148.89	-41.85	157.96	-57.04	161.62	-43.06	170.68	-66.47	260.68	-52.49	269.75
400	-28.59	268.74	-55.83	148.89	-41.85	157.96	-57.04	161.62	-43.06	170.68	-66.47	260.68	-52.49	269.75
500	-28.59	268.74	-55.83	148.89	-41.85	157.96	-57.04	161.62	-43.06	170.68	-66.47	260.68	-52.49	269.75
600	-28.59	268.74	-55.83	148.89	-41.85	157.96	-57.04	161.62	-43.06	170.68	-66.47	260.68	-52.49	269.75
700	-28.59	268.74	-55.83	148.89	-41.85	157.96	-57.04	161.62	-43.06	170.68	-66.47	260.68	-52.49	269.75
800	-28.59	268.74	-55.83	148.89	-41.85	157.96	-57.04	161.62	-43.06	170.68	-66.47	260.68	-52.49	269.75
900	-28.59	268.74	-55.83	148.89	-41.85	157.96	-57.04	161.62	-43.06	170.68	-66.47	260.68	-52.49	269.75
1000	-28.59	268.74	-55.83	148.89	-41.85	157.96	-57.04	161.62	-43.06	170.68	-66.47	260.68	-52.49	269.75
1200	-28.59	268.74	-55.83	148.89	-41.85	157.96	-57.04	161.62	-43.06	170.68	-66.47	260.68	-52.49	269.75
1500	-28.59	268.74	-55.83	148.89	-41.85	157.96	-57.04	161.62	-43.06	170.68	-66.47	260.68	-52.49	269.75
2000	-28.59	268.74	-55.83	148.89	-41.85	157.96	-57.04	161.62	-43.06	170.68	-66.47	260.68	-52.49	269.75
5000	-28.59	268.74	-55.83	148.89	-41.85	157.96	-57.04	161.62	-43.06	170.68	-66.47	260.68	-52.49	269.75
10000	-28.59	268.74	-55.83	148.89	-41.85	157.96	-57.04	161.62	-43.06	170.68	-66.47	260.68	-52.49	269.75
50000	-28.59	268.74	-55.83	148.89	-41.85	157.96	-57.04	161.62	-43.06	170.68	-66.47	260.68	-52.49	269.75
Tangent	-28.59	268.74	-55.83	148.89	-41.85	157.96	-57.04	161.62	-43.06	170.68	-66.47	260.68	-52.49	269.75

Met Council PROPOSED LOW FLOOR LIGHT RAIL VEHICLE

TABLE 3A - VEHICLE DYNAMIC ENVELOPE - OUTSIDE OF CURVE

Cross Level Variation = 0.5 in
Superelevation = 2.0 in

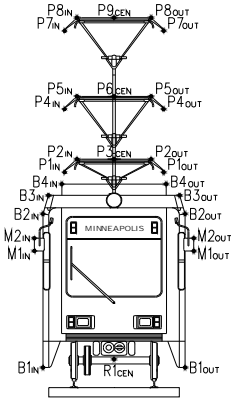

NOTES:

Coordinates shown are in english units (mm)

Maximum values for each radius are shown in Bold Italicized font

All coordinates shown are referenced from a point located at 1/2 track gauge and top of rail (0,0)

Superelevation is applied relative to top of low rail

Points R1_{CEN}, P3_{CEN}, P6_{CEN} and P9_{CEN} are not specific to either Outside or Inside of curve

B# = LFLRV Body Points

M# = LFLRV Mirror Points

P# = LFLRV Pantograph Points

R# = LFLRV Roll Center Point

File Name: MIN-S.XLS

Revision By: SCA

Revision Date: 02/22/99

RADIUS FEET	R1 _{CEN}		B1 _{OUT}		M1 _{OUT}		M2 _{OUT}		B2 _{OUT}		B3 _{OUT}		B4 _{OUT}	
	X	Y	X	Y	X	Y	X	Y	X	Y	X	Y	X	Y
82	-0.66	16.24	75.91	7.08	84.80	95.80	85.23	114.72	80.43	132.41	67.42	146.19	62.63	153.51
100	-0.66	16.24	72.02	7.08	81.76	95.80	82.19	114.72	76.54	132.41	65.73	146.19	60.15	153.51
150	-0.66	16.24	65.81	7.08	76.86	95.80	77.29	114.72	70.33	132.41	63.02	146.19	56.22	153.51
200	-0.66	16.24	62.57	7.08	74.29	95.80	74.72	114.72	67.09	132.41	61.58	146.19	54.18	153.51
300	-0.66	16.24	59.26	7.08	71.63	95.80	72.06	114.72	63.78	132.41	60.10	146.19	52.09	153.51
400	-0.66	16.24	58.42	7.08	70.27	95.80	70.70	114.72	62.94	132.41	59.34	146.19	51.03	153.51
500	-0.66	16.24	57.96	7.08	69.44	95.80	69.88	114.72	62.48	132.41	58.88	146.19	50.39	153.51
600	-0.66	16.24	57.65	7.08	68.89	95.80	69.32	114.72	62.17	132.41	58.57	146.19	49.95	153.51
700	-0.66	16.24	57.43	7.08	68.49	95.80	68.92	114.72	61.95	132.41	58.34	146.19	49.64	153.51
800	-0.66	16.24	57.26	7.08	68.19	95.80	68.62	114.72	61.78	132.41	58.18	146.19	49.41	153.51
900	-0.66	16.24	57.13	7.08	67.96	95.80	68.39	114.72	61.65	132.41	58.04	146.19	49.23	153.51
1000	-0.66	16.24	57.03	7.08	67.77	95.80	68.20	114.72	61.55	132.41	57.94	146.19	49.09	153.51
1200	-0.66	16.24	56.87	7.08	67.49	95.80	67.92	114.72	61.39	132.41	57.78	146.19	48.87	153.51
1500	-0.66	16.24	56.71	7.08	67.21	95.80	67.64	114.72	61.23	132.41	57.62	146.19	48.65	153.51
2000	-0.66	16.24	56.55	7.08	66.92	95.80	67.36	114.72	61.07	132.41	57.46	146.19	48.43	153.51
5000	-0.66	16.24	56.26	7.08	66.41	95.80	66.84	114.72	60.78	132.41	57.18	146.19	48.03	153.51
10000	-0.66	16.24	56.17	7.08	66.24	95.80	66.67	114.72	60.69	132.41	57.08	146.19	47.90	153.51
50000	-0.66	16.24	56.09	7.08	66.10	95.80	66.53	114.72	60.61	132.41	57.00	146.19	47.80	153.51
Tangent	-0.66	16.24	56.07	7.08	66.07	95.80	66.50	114.72	60.59	132.41	56.98	146.19	47.77	153.51

RADIUS FEET	P3 _{CEN}		P1 _{OUT}		P2 _{OUT}		P4 _{OUT}		P5 _{OUT}		P7 _{OUT}		P8 _{OUT}	
	X	Y	X	Y	X	Y	X	Y	X	Y	X	Y	X	Y
82	-20.59	157.20	48.57	150.77	34.03	159.03	49.14	163.44	34.60	171.71	53.55	262.07	39.01	270.38
100	-20.59	157.20	48.57	150.77	34.03	159.03	49.14	163.44	34.60	171.71	53.55	262.07	39.01	270.38
150	-20.59	157.20	48.57	150.77	34.03	159.03	49.14	163.44	34.60	171.71	53.55	262.07	39.01	270.38
200	-20.59	157.20	48.57	150.77	34.03	159.03	49.14	163.44	34.60	171.71	53.55	262.07	39.01	270.38
300	-20.59	157.20	48.57	150.77	34.03	159.03	49.14	163.44	34.60	171.71	53.55	262.07	39.01	270.38
400	-20.59	157.20	48.57	150.77	34.03	159.03	49.14	163.44	34.60	171.71	53.55	262.07	39.01	270.38
500	-20.59	157.20	48.57	150.77	34.03	159.03	49.14	163.44	34.60	171.71	53.55	262.07	39.01	270.38
600	-20.59	157.20	48.57	150.77	34.03	159.03	49.14	163.44	34.60	171.71	53.55	262.07	39.01	270.38
700	-20.59	157.20	48.57	150.77	34.03	159.03	49.14	163.44	34.60	171.71	53.55	262.07	39.01	270.38
800	-20.59	157.20	48.57	150.77	34.03	159.03	49.14	163.44	34.60	171.71	53.55	262.07	39.01	270.38
900	-20.59	157.20	48.57	150.77	34.03	159.03	49.14	163.44	34.60	171.71	53.55	262.07	39.01	270.38
1000	-20.59	157.20	48.57	150.77	34.03	159.03	49.14	163.44	34.60	171.71	53.55	262.07	39.01	270.38
1200	-20.59	157.20	48.57	150.77	34.03	159.03	49.14	163.44	34.60	171.71	53.55	262.07	39.01	270.38
1500	-20.59	157.20	48.57	150.77	34.03	159.03	49.14	163.44	34.60	171.71	53.55	262.07	39.01	270.38
2000	-20.59	157.20	48.57	150.77	34.03	159.03	49.14	163.44	34.60	171.71	53.55	262.07	39.01	270.38
5000	-20.59	157.20	48.57	150.77	34.03	159.03	49.14	163.44	34.60	171.71	53.55	262.07	39.01	270.38
10000	-20.59	157.20	48.57	150.77	34.03	159.03	49.14	163.44	34.60	171.71	53.55	262.07	39.01	270.38
50000	-20.59	157.20	48.57	150.77	34.03	159.03	49.14	163.44	34.60	171.71	53.55	262.07	39.01	270.38
Tangent	-20.59	157.20	48.57	150.77	34.03	159.03	49.14	163.44	34.60	171.71	53.55	262.07	39.01	270.38

Met Council PROPOSED LOW FLOOR LIGHT RAIL VEHICLE

TABLE 3B - VEHICLE DYNAMIC ENVELOPE - INSIDE OF CURVE

Cross Level Variation = 0.5 in
Superelevation = 2.0 in

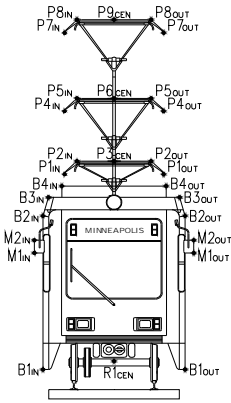

NOTES:

Coordinates shown are in english units (mm)

Maximum values for each radius are shown in Bold Italicized font

All coordinates shown are referenced from a point located at 1/2 track gauge and top of rail (0,0)

Superelevation is applied relative to top of low rail

Points R1_{CEN}, P3_{CEN}, P6_{CEN} and P9_{CEN} are not specific to either Outside or Inside of curve

B# = LFLRV Body Points

M# = LFLRV Mirror Points

P# = LFLRV Pantograph Points

R# = LFLRV Roll Center Point

File Name: MIN-S.XLS
Revision By: SCA
Revision Date: 02/22/99

RADIUS FEET	P6 _{CEN}		B1 _{IN}		M1 _{IN}		M2 _{IN}		B2 _{IN}		B3 _{IN}		B4 _{IN}	
	X	Y	X	Y	X	Y	X	Y	X	Y	X	Y	X	Y
82	-22.02	169.95	-71.54	3.57	-80.27	91.41	-81.36	111.26	-83.46	129.47	-80.84	143.62	-71.98	151.64
100	-22.02	169.95	-68.71	3.57	-77.43	91.41	-78.52	111.26	-80.63	129.47	-78.01	143.62	-69.15	151.64
150	-22.02	169.95	-64.44	3.57	-73.17	91.41	-74.26	111.26	-76.37	129.47	-73.75	143.62	-64.88	151.64
200	-22.02	169.95	-62.32	3.57	-71.05	91.41	-72.14	111.26	-74.24	129.47	-71.63	143.62	-62.76	151.64
300	-22.02	169.95	-60.21	3.57	-68.93	91.41	-70.02	111.26	-72.13	129.47	-69.51	143.62	-60.64	151.64
400	-22.02	169.95	-59.15	3.57	-67.99	91.41	-69.08	111.26	-71.07	129.47	-68.45	143.62	-59.59	151.64
500	-22.02	169.95	-58.52	3.57	-68.88	91.41	-69.97	111.26	-70.44	129.47	-67.82	143.62	-58.95	151.64
600	-22.02	169.95	-58.09	3.57	-69.47	91.41	-70.56	111.26	-70.02	129.47	-67.40	143.62	-58.53	151.64
700	-22.02	169.95	-57.79	3.57	-69.89	91.41	-70.98	111.26	-69.72	129.47	-67.10	143.62	-58.23	151.64
800	-22.02	169.95	-57.57	3.57	-70.20	91.41	-71.29	111.26	-69.49	129.47	-66.87	143.62	-58.01	151.64
900	-22.02	169.95	-57.39	3.57	-70.44	91.41	-71.53	111.26	-69.32	129.47	-66.70	143.62	-57.83	151.64
1000	-22.02	169.95	-57.25	3.57	-70.64	91.41	-71.73	111.26	-69.17	129.47	-66.56	143.62	-57.69	151.64
1200	-22.02	169.95	-57.04	3.57	-70.93	91.41	-72.02	111.26	-68.96	129.47	-66.34	143.62	-57.48	151.64
1500	-22.02	169.95	-56.83	3.57	-71.22	91.41	-72.31	111.26	-68.75	129.47	-66.13	143.62	-57.27	151.64
2000	-22.02	169.95	-56.62	3.57	-71.51	91.41	-72.60	111.26	-68.54	129.47	-65.92	143.62	-57.06	151.64
5000	-22.02	169.95	-56.71	3.57	-72.03	91.41	-73.12	111.26	-68.64	129.47	-66.02	143.62	-57.35	151.64
10000	-22.02	169.95	-56.81	3.57	-72.20	91.41	-73.29	111.26	-68.73	129.47	-66.12	143.62	-57.49	151.64
50000	-22.02	169.95	-56.89	3.57	-72.34	91.41	-73.43	111.26	-68.81	129.47	-66.19	143.62	-57.59	151.64
Tangent	-22.02	169.95	-56.91	3.57	-72.37	91.41	-73.46	111.26	-68.83	129.47	-66.21	143.62	-57.62	151.64

RADIUS FEET	P9 _{CEN}		P1 _{IN}		P2 _{IN}		P4 _{IN}		P5 _{IN}		P7 _{IN}		P8 _{IN}	
	X	Y	X	Y	X	Y	X	Y	X	Y	X	Y	X	Y
82	-33.11	269.16	-58.23	148.85	-44.44	158.17	-59.65	161.59	-45.87	170.91	-70.75	260.74	-56.96	270.06
100	-33.11	269.16	-58.23	148.85	-44.44	158.17	-59.65	161.59	-45.87	170.91	-70.75	260.74	-56.96	270.06
150	-33.11	269.16	-58.23	148.85	-44.44	158.17	-59.65	161.59	-45.87	170.91	-70.75	260.74	-56.96	270.06
200	-33.11	269.16	-58.23	148.85	-44.44	158.17	-59.65	161.59	-45.87	170.91	-70.75	260.74	-56.96	270.06
300	-33.11	269.16	-58.23	148.85	-44.44	158.17	-59.65	161.59	-45.87	170.91	-70.75	260.74	-56.96	270.06
400	-33.11	269.16	-58.23	148.85	-44.44	158.17	-59.65	161.59	-45.87	170.91	-70.75	260.74	-56.96	270.06
500	-33.11	269.16	-58.23	148.85	-44.44	158.17	-59.65	161.59	-45.87	170.91	-70.75	260.74	-56.96	270.06
600	-33.11	269.16	-58.23	148.85	-44.44	158.17	-59.65	161.59	-45.87	170.91	-70.75	260.74	-56.96	270.06
700	-33.11	269.16	-58.23	148.85	-44.44	158.17	-59.65	161.59	-45.87	170.91	-70.75	260.74	-56.96	270.06
800	-33.11	269.16	-58.23	148.85	-44.44	158.17	-59.65	161.59	-45.87	170.91	-70.75	260.74	-56.96	270.06
900	-33.11	269.16	-58.23	148.85	-44.44	158.17	-59.65	161.59	-45.87	170.91	-70.75	260.74	-56.96	270.06
1000	-33.11	269.16	-58.23	148.85	-44.44	158.17	-59.65	161.59	-45.87	170.91	-70.75	260.74	-56.96	270.06
1200	-33.11	269.16	-58.23	148.85	-44.44	158.17	-59.65	161.59	-45.87	170.91	-70.75	260.74	-56.96	270.06
1500	-33.11	269.16	-58.23	148.85	-44.44	158.17	-59.65	161.59	-45.87	170.91	-70.75	260.74	-56.96	270.06
2000	-33.11	269.16	-58.23	148.85	-44.44	158.17	-59.65	161.59	-45.87	170.91	-70.75	260.74	-56.96	270.06
5000	-33.11	269.16	-58.23	148.85	-44.44	158.17	-59.65	161.59	-45.87	170.91	-70.75	260.74	-56.96	270.06
10000	-33.11	269.16	-58.23	148.85	-44.44	158.17	-59.65	161.59	-45.87	170.91	-70.75	260.74	-56.96	270.06
50000	-33.11	269.16	-58.23	148.85	-44.44	158.17	-59.65	161.59	-45.87	170.91	-70.75	260.74	-56.96	270.06
Tangent	-33.11	269.16	-58.23	148.85	-44.44	158.17	-59.65	161.59	-45.87	170.91	-70.75	260.74	-56.96	270.06

Met Council PROPOSED LOW FLOOR LIGHT RAIL VEHICLE

TABLE 4A - VEHICLE DYNAMIC ENVELOPE - OUTSIDE OF CURVE

Cross Level Variation = 0.5 in
Superelevation = 3.0 in

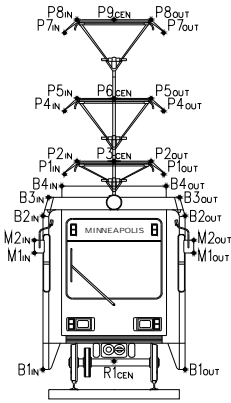

NOTES:

Coordinates shown are in english units (mm)

Maximum values for each radius are shown in Bold Italicized font

All coordinates shown are referenced from a point located at 1/2 track gauge and top of rail (0,0)

Superelevation is applied relative to top of low rail

Points R1_{CEN}, P3_{CEN}, P6_{CEN} and P9_{CEN} are not specific to either Outside or Inside of curve

B# = LFLRV Body Points

M# = LFLRV Mirror Points

P# = LFLRV Pantograph Points

R# = LFLRV Roll Center Point

File Name: MIN-S.XLS
Revision By: SCA
Revision Date: 02/22/99

RADIUS FEET	R1 _{CEN}		B1 _{OUT}		M1 _{OUT}		M2 _{OUT}		B2 _{OUT}		B3 _{OUT}		B4 _{OUT}	
	X	Y	X	Y	X	Y	X	Y	X	Y	X	Y	X	Y
82	-0.94	16.73	75.66	8.45	83.17	97.33	83.44	116.00	78.33	133.55	65.06	147.23	60.13	154.36
100	-0.94	16.73	71.76	8.45	80.13	97.33	80.40	116.00	74.43	133.55	63.38	147.23	57.65	154.36
150	-0.94	16.73	65.55	8.45	75.23	97.33	75.50	116.00	68.22	133.55	60.66	147.23	53.72	154.36
200	-0.94	16.73	62.32	8.45	72.66	97.33	72.93	116.00	64.99	133.55	59.23	147.23	51.68	154.36
300	-0.94	16.73	59.00	8.45	70.00	97.33	70.27	116.00	61.67	133.55	57.75	147.23	49.59	154.36
400	-0.94	16.73	58.17	8.45	68.64	97.33	68.91	116.00	60.83	133.55	56.99	147.23	48.53	154.36
500	-0.94	16.73	57.71	8.45	67.82	97.33	68.09	116.00	60.37	133.55	56.53	147.23	47.88	154.36
600	-0.94	16.73	57.40	8.45	67.26	97.33	67.53	116.00	60.06	133.55	56.21	147.23	47.45	154.36
700	-0.94	16.73	57.17	8.45	66.86	97.33	67.13	116.00	59.84	133.55	55.99	147.23	47.14	154.36
800	-0.94	16.73	57.01	8.45	66.56	97.33	66.83	116.00	59.67	133.55	55.82	147.23	46.91	154.36
900	-0.94	16.73	56.88	8.45	66.33	97.33	66.60	116.00	59.54	133.55	55.69	147.23	46.73	154.36
1000	-0.94	16.73	56.77	8.45	66.14	97.33	66.41	116.00	59.44	133.55	55.59	147.23	46.58	154.36
1200	-0.94	16.73	56.61	8.45	65.86	97.33	66.13	116.00	59.28	133.55	55.43	147.23	46.37	154.36
1500	-0.94	16.73	56.45	8.45	65.58	97.33	65.85	116.00	59.12	133.55	55.27	147.23	46.15	154.36
2000	-0.94	16.73	56.30	8.45	65.29	97.33	65.56	116.00	58.96	133.55	55.11	147.23	45.93	154.36
5000	-0.94	16.73	56.01	8.45	64.78	97.33	65.05	116.00	58.68	133.55	54.82	147.23	45.53	154.36
10000	-0.94	16.73	55.91	8.45	64.61	97.33	64.88	116.00	58.58	133.55	54.73	147.23	45.40	154.36
50000	-0.94	16.73	55.84	8.45	64.47	97.33	64.74	116.00	58.50	133.55	54.65	147.23	45.29	154.36
Tangent	-0.94	16.73	55.82	8.45	64.44	97.33	64.71	116.00	58.48	133.55	54.63	147.23	45.27	154.36

RADIUS FEET	P3 _{CEN}		P1 _{OUT}		P2 _{OUT}		P4 _{OUT}		P5 _{OUT}		P7 _{OUT}		P8 _{OUT}	
	X	Y	X	Y	X	Y	X	Y	X	Y	X	Y	X	Y
82	-23.23	157.71	46.12	151.65	31.40	159.64	46.47	164.29	31.75	172.28	49.22	262.72	34.50	270.83
100	-23.23	157.71	46.12	151.65	31.40	159.64	46.47	164.29	31.75	172.28	49.22	262.72	34.50	270.83
150	-23.23	157.71	46.12	151.65	31.40	159.64	46.47	164.29	31.75	172.28	49.22	262.72	34.50	270.83
200	-23.23	157.71	46.12	151.65	31.40	159.64	46.47	164.29	31.75	172.28	49.22	262.72	34.50	270.83
300	-23.23	157.71	46.12	151.65	31.40	159.64	46.47	164.29	31.75	172.28	49.22	262.72	34.50	270.83
400	-23.23	157.71	46.12	151.65	31.40	159.64	46.47	164.29	31.75	172.28	49.22	262.72	34.50	270.83
500	-23.23	157.71	46.12	151.65	31.40	159.64	46.47	164.29	31.75	172.28	49.22	262.72	34.50	270.83
600	-23.23	157.71	46.12	151.65	31.40	159.64	46.47	164.29	31.75	172.28	49.22	262.72	34.50	270.83
700	-23.23	157.71	46.12	151.65	31.40	159.64	46.47	164.29	31.75	172.28	49.22	262.72	34.50	270.83
800	-23.23	157.71	46.12	151.65	31.40	159.64	46.47	164.29	31.75	172.28	49.22	262.72	34.50	270.83
900	-23.23	157.71	46.12	151.65	31.40	159.64	46.47	164.29	31.75	172.28	49.22	262.72	34.50	270.83
1000	-23.23	157.71	46.12	151.65	31.40	159.64	46.47	164.29	31.75	172.28	49.22	262.72	34.50	270.83
1200	-23.23	157.71	46.12	151.65	31.40	159.64	46.47	164.29	31.75	172.28	49.22	262.72	34.50	270.83
1500	-23.23	157.71	46.12	151.65	31.40	159.64	46.47	164.29	31.75	172.28	49.22	262.72	34.50	270.83
2000	-23.23	157.71	46.12	151.65	31.40	159.64	46.47	164.29	31.75	172.28	49.22	262.72	34.50	270.83
5000	-23.23	157.71	46.12	151.65	31.40	159.64	46.47	164.29	31.75	172.28	49.22	262.72	34.50	270.83
10000	-23.23	157.71	46.12	151.65	31.40	159.64	46.47	164.29	31.75	172.28	49.22	262.72	34.50	270.83
50000	-23.23	157.71	46.12	151.65	31.40	159.64	46.47	164.29	31.75	172.28	49.22	262.72	34.50	270.83
Tangent	-23.23	157.71	46.12	151.65	31.40	159.64	46.47	164.29	31.75	172.28	49.22	262.72	34.50	270.83

Met Council PROPOSED LOW FLOOR LIGHT RAIL VEHICLE

TABLE 4B - VEHICLE DYNAMIC ENVELOPE - INSIDE OF CURVE

Cross Level Variation = 0.5 in
Superelevation = 3.0 in

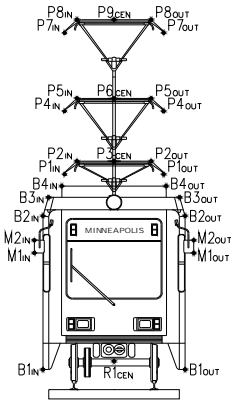

NOTES:

Coordinates shown are in english units (mm)

Maximum values for each radius are shown in Bold Italicized font

All coordinates shown are referenced from a point located at 1/2 track gauge and top of rail (0,0)

Superelevation is applied relative to top of low rail

Points R1_{CEN}, P3_{CEN}, P6_{CEN} and P9_{CEN} are not specific to either Outside or Inside of curve

B# = LFLRV Body Points

M# = LFLRV Mirror Points

P# = LFLRV Pantograph Points

R# = LFLRV Roll Center Point

File Name: MIN-S.XLS
Revision By: SCA
Revision Date: 02/22/99

RADIUS FEET	P6 _{CEN}		B1 _{IN}		M1 _{IN}		M2 _{IN}		B2 _{IN}		B3 _{IN}		B4 _{IN}	
	X	Y	X	Y	X	Y	X	Y	X	Y	X	Y	X	Y
82	-24.87	170.46	-71.73	3.19	-81.81	90.74	-83.06	110.82	-85.49	129.14	-83.12	143.37	-74.42	151.56
100	-24.87	170.46	-68.90	3.19	-78.98	90.74	-80.23	110.82	-82.66	129.14	-80.29	143.37	-71.58	151.56
150	-24.87	170.46	-64.63	3.19	-74.71	90.74	-75.97	110.82	-78.39	129.14	-76.02	143.37	-67.32	151.56
200	-24.87	170.46	-62.51	3.19	-72.59	90.74	-73.84	110.82	-76.27	129.14	-73.90	143.37	-65.20	151.56
300	-24.87	170.46	-60.39	3.19	-70.48	90.74	-71.73	110.82	-74.16	129.14	-71.79	143.37	-63.08	151.56
400	-24.87	170.46	-59.34	3.19	-69.53	90.74	-70.78	110.82	-73.10	129.14	-70.73	143.37	-62.03	151.56
500	-24.87	170.46	-58.70	3.19	-70.42	90.74	-71.67	110.82	-72.47	129.14	-70.10	143.37	-61.39	151.56
600	-24.87	170.46	-58.28	3.19	-71.01	90.74	-72.26	110.82	-72.05	129.14	-69.68	143.37	-60.97	151.56
700	-24.87	170.46	-57.98	3.19	-71.43	90.74	-72.68	110.82	-71.75	129.14	-69.38	143.37	-60.67	151.56
800	-24.87	170.46	-57.76	3.19	-71.75	90.74	-73.00	110.82	-71.52	129.14	-69.15	143.37	-60.44	151.56
900	-24.87	170.46	-57.58	3.19	-71.99	90.74	-73.24	110.82	-71.34	129.14	-68.97	143.37	-60.27	151.56
1000	-24.87	170.46	-57.44	3.19	-72.18	90.74	-73.44	110.82	-71.20	129.14	-68.83	143.37	-60.13	151.56
1200	-24.87	170.46	-57.23	3.19	-72.47	90.74	-73.73	110.82	-70.99	129.14	-68.62	143.37	-59.92	151.56
1500	-24.87	170.46	-57.02	3.19	-72.76	90.74	-74.02	110.82	-70.78	129.14	-68.41	143.37	-59.71	151.56
2000	-24.87	170.46	-56.81	3.19	-73.05	90.74	-74.31	110.82	-70.57	129.14	-68.20	143.37	-59.50	151.56
5000	-24.87	170.46	-56.90	3.19	-73.57	90.74	-74.82	110.82	-70.67	129.14	-68.30	143.37	-59.79	151.56
10000	-24.87	170.46	-57.00	3.19	-73.74	90.74	-75.00	110.82	-70.76	129.14	-68.39	143.37	-59.93	151.56
50000	-24.87	170.46	-57.08	3.19	-73.88	90.74	-75.13	110.82	-70.84	129.14	-68.47	143.37	-60.03	151.56
Tangent	-24.87	170.46	-57.10	3.19	-73.92	90.74	-75.17	110.82	-70.86	129.14	-68.49	143.37	-60.06	151.56

RADIUS FEET	P9 _{CEN}		P1 _{IN}		P2 _{IN}		P4 _{IN}		P5 _{IN}		P7 _{IN}		P8 _{IN}	
	X	Y	X	Y	X	Y	X	Y	X	Y	X	Y	X	Y
82	-37.62	269.71	-60.62	148.76	-47.03	158.34	-62.26	161.51	-48.67	171.09	-75.01	260.72	-61.42	270.30
100	-37.62	269.71	-60.62	148.76	-47.03	158.34	-62.26	161.51	-48.67	171.09	-75.01	260.72	-61.42	270.30
150	-37.62	269.71	-60.62	148.76	-47.03	158.34	-62.26	161.51	-48.67	171.09	-75.01	260.72	-61.42	270.30
200	-37.62	269.71	-60.62	148.76	-47.03	158.34	-62.26	161.51	-48.67	171.09	-75.01	260.72	-61.42	270.30
300	-37.62	269.71	-60.62	148.76	-47.03	158.34	-62.26	161.51	-48.67	171.09	-75.01	260.72	-61.42	270.30
400	-37.62	269.71	-60.62	148.76	-47.03	158.34	-62.26	161.51	-48.67	171.09	-75.01	260.72	-61.42	270.30
500	-37.62	269.71	-60.62	148.76	-47.03	158.34	-62.26	161.51	-48.67	171.09	-75.01	260.72	-61.42	270.30
600	-37.62	269.71	-60.62	148.76	-47.03	158.34	-62.26	161.51	-48.67	171.09	-75.01	260.72	-61.42	270.30
700	-37.62	269.71	-60.62	148.76	-47.03	158.34	-62.26	161.51	-48.67	171.09	-75.01	260.72	-61.42	270.30
800	-37.62	269.71	-60.62	148.76	-47.03	158.34	-62.26	161.51	-48.67	171.09	-75.01	260.72	-61.42	270.30
900	-37.62	269.71	-60.62	148.76	-47.03	158.34	-62.26	161.51	-48.67	171.09	-75.01	260.72	-61.42	270.30
1000	-37.62	269.71	-60.62	148.76	-47.03	158.34	-62.26	161.51	-48.67	171.09	-75.01	260.72	-61.42	270.30
1200	-37.62	269.71	-60.62	148.76	-47.03	158.34	-62.26	161.51	-48.67	171.09	-75.01	260.72	-61.42	270.30
1500	-37.62	269.71	-60.62	148.76	-47.03	158.34	-62.26	161.51	-48.67	171.09	-75.01	260.72	-61.42	270.30
2000	-37.62	269.71	-60.62	148.76	-47.03	158.34	-62.26	161.51	-48.67	171.09	-75.01	260.72	-61.42	270.30
5000	-37.62	269.71	-60.62	148.76	-47.03	158.34	-62.26	161.51	-48.67	171.09	-75.01	260.72	-61.42	270.30
10000	-37.62	269.71	-60.62	148.76	-47.03	158.34	-62.26	161.51	-48.67	171.09	-75.01	260.72	-61.42	270.30
50000	-37.62	269.71	-60.62	148.76	-47.03	158.34	-62.26	161.51	-48.67	171.09	-75.01	260.72	-61.42	270.30
Tangent	-37.62	269.71	-60.62	148.76	-47.03	158.34	-62.26	161.51	-48.67	171.09	-75.01	260.72	-61.42	270.30

Met Council PROPOSED LOW FLOOR LIGHT RAIL VEHICLE

TABLE 5A - VEHICLE DYNAMIC ENVELOPE - OUTSIDE OF CURVE

Cross Level Variation = 0.5 in
Superelevation = 4.0 in

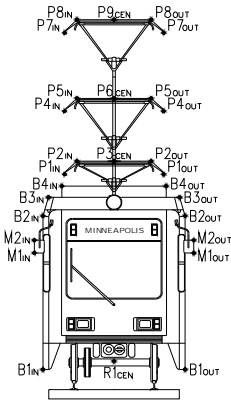

RADIUS FEET	R1 _{CEN}		B1 _{OUT}		M1 _{OUT}		M2 _{OUT}		B2 _{OUT}		B3 _{OUT}		B4 _{OUT}	
	X	Y	X	Y	X	Y	X	Y	X	Y	X	Y	X	Y
82	-1.22	17.22	75.38	9.81	81.52	98.83	81.62	117.24	76.20	134.65	62.69	148.23	57.61	155.18
100	-1.22	17.22	71.48	9.81	78.48	98.83	78.58	117.24	72.30	134.65	61.01	148.23	55.14	155.18
150	-1.22	17.22	65.27	9.81	73.58	98.83	73.69	117.24	66.09	134.65	58.29	148.23	51.21	155.18
200	-1.22	17.22	62.04	9.81	71.01	98.83	71.11	117.24	62.86	134.65	56.86	148.23	49.16	155.18
300	-1.22	17.22	58.72	9.81	68.35	98.83	68.46	117.24	59.54	134.65	55.38	148.23	47.08	155.18
400	-1.22	17.22	57.89	9.81	66.99	98.83	67.10	117.24	58.71	134.65	54.62	148.23	46.01	155.18
500	-1.22	17.22	57.43	9.81	66.17	98.83	66.27	117.24	58.25	134.65	54.15	148.23	45.37	155.18
600	-1.22	17.22	57.12	9.81	65.61	98.83	65.72	117.24	57.94	134.65	53.84	148.23	44.94	155.18
700	-1.22	17.22	56.90	9.81	65.21	98.83	65.32	117.24	57.71	134.65	53.62	148.23	44.63	155.18
800	-1.22	17.22	56.73	9.81	64.91	98.83	65.02	117.24	57.55	134.65	53.45	148.23	44.40	155.18
900	-1.22	17.22	56.60	9.81	64.68	98.83	64.78	117.24	57.42	134.65	53.32	148.23	44.21	155.18
1000	-1.22	17.22	56.49	9.81	64.49	98.83	64.60	117.24	57.31	134.65	53.22	148.23	44.07	155.18
1200	-1.22	17.22	56.34	9.81	64.21	98.83	64.32	117.24	57.15	134.65	53.06	148.23	43.85	155.18
1500	-1.22	17.22	56.18	9.81	63.93	98.83	64.03	117.24	56.99	134.65	52.90	148.23	43.63	155.18
2000	-1.22	17.22	56.02	9.81	63.64	98.83	63.75	117.24	56.84	134.65	52.74	148.23	43.41	155.18
5000	-1.22	17.22	55.73	9.81	63.13	98.83	63.24	117.24	56.55	134.65	52.45	148.23	43.02	155.18
10000	-1.22	17.22	55.63	9.81	62.96	98.83	63.07	117.24	56.45	134.65	52.36	148.23	42.88	155.18
50000	-1.22	17.22	55.56	9.81	62.82	98.83	62.93	117.24	56.38	134.65	52.28	148.23	42.78	155.18
Tangent	-1.22	17.22	55.54	9.81	62.79	98.83	62.89	117.24	56.36	134.65	52.26	148.23	42.75	155.18

NOTES:

Coordinates shown are in english units (mm)

Maximum values for each radius are shown in Bold Italicized font

All coordinates shown are referenced from a point located at 1/2 track gauge and top of rail (0,0)

Superelevation is applied relative to top of low rail

Points R1_{CEN}, P3_{CEN}, P6_{CEN} and P9_{CEN} are not specific to either Outside or Inside of curve

B# = LFLRV Body Points

M# = LFLRV Mirror Points

P# = LFLRV Pantograph Points

R# = LFLRV Roll Center Point

File Name: MIN-S.XLS
Revision By: SCA
Revision Date: 02/22/99

RADIUS FEET	P3 _{CEN}		P1 _{OUT}		P2 _{OUT}		P4 _{OUT}		P5 _{OUT}		P7 _{OUT}		P8 _{OUT}	
	X	Y	X	Y	X	Y	X	Y	X	Y	X	Y	X	Y
82	-25.86	158.21	43.65	152.48	28.76	160.19	43.79	165.09	28.90	172.81	44.86	263.29	29.97	271.29
100	-25.86	158.21	43.65	152.48	28.76	160.19	43.79	165.09	28.90	172.81	44.86	263.29	29.97	271.29
150	-25.86	158.21	43.65	152.48	28.76	160.19	43.79	165.09	28.90	172.81	44.86	263.29	29.97	271.29
200	-25.86	158.21	43.65	152.48	28.76	160.19	43.79	165.09	28.90	172.81	44.86	263.29	29.97	271.29
300	-25.86	158.21	43.65	152.48	28.76	160.19	43.79	165.09	28.90	172.81	44.86	263.29	29.97	271.29
400	-25.86	158.21	43.65	152.48	28.76	160.19	43.79	165.09	28.90	172.81	44.86	263.29	29.97	271.29
500	-25.86	158.21	43.65	152.48	28.76	160.19	43.79	165.09	28.90	172.81	44.86	263.29	29.97	271.29
600	-25.86	158.21	43.65	152.48	28.76	160.19	43.79	165.09	28.90	172.81	44.86	263.29	29.97	271.29
700	-25.86	158.21	43.65	152.48	28.76	160.19	43.79	165.09	28.90	172.81	44.86	263.29	29.97	271.29
800	-25.86	158.21	43.65	152.48	28.76	160.19	43.79	165.09	28.90	172.81	44.86	263.29	29.97	271.29
900	-25.86	158.21	43.65	152.48	28.76	160.19	43.79	165.09	28.90	172.81	44.86	263.29	29.97	271.29
1000	-25.86	158.21	43.65	152.48	28.76	160.19	43.79	165.09	28.90	172.81	44.86	263.29	29.97	271.29
1200	-25.86	158.21	43.65	152.48	28.76	160.19	43.79	165.09	28.90	172.81	44.86	263.29	29.97	271.29
1500	-25.86	158.21	43.65	152.48	28.76	160.19	43.79	165.09	28.90	172.81	44.86	263.29	29.97	271.29
2000	-25.86	158.21	43.65	152.48	28.76	160.19	43.79	165.09	28.90	172.81	44.86	263.29	29.97	271.29
5000	-25.86	158.21	43.65	152.48	28.76	160.19	43.79	165.09	28.90	172.81	44.86	263.29	29.97	271.29
10000	-25.86	158.21	43.65	152.48	28.76	160.19	43.79	165.09	28.90	172.81	44.86	263.29	29.97	271.29
50000	-25.86	158.21	43.65	152.48	28.76	160.19	43.79	165.09	28.90	172.81	44.86	263.29	29.97	271.29
Tangent	-25.86	158.21	43.65	152.48	28.76	160.19	43.79	165.09	28.90	172.81	44.86	263.29	29.97	271.29

Met Council PROPOSED LOW FLOOR LIGHT RAIL VEHICLE

TABLE 5B - VEHICLE DYNAMIC ENVELOPE - INSIDE OF CURVE

Cross Level Variation = 0.5 in
Superelevation = 4.0 in

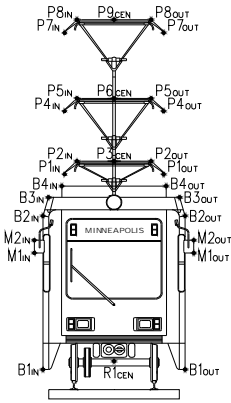

RADIUS FEET	P6 _{CEN}		B1 _{IN}		M1 _{IN}		M2 _{IN}		B2 _{IN}		B3 _{IN}		B4 _{IN}	
	X	Y	X	Y	X	Y	X	Y	X	Y	X	Y	X	Y
82	-27.72	170.96	-71.91	2.81	-83.34	90.05	-84.76	110.35	-87.51	128.78	-85.39	143.08	-76.85	151.45
100	-27.72	170.96	-69.08	2.81	-80.51	90.05	-81.92	110.35	-84.67	128.78	-82.55	143.08	-74.01	151.45
150	-27.72	170.96	-64.81	2.81	-76.24	90.05	-77.66	110.35	-80.41	128.78	-78.29	143.08	-69.75	151.45
200	-27.72	170.96	-62.69	2.81	-74.12	90.05	-75.54	110.35	-78.29	128.78	-76.17	143.08	-67.63	151.45
300	-27.72	170.96	-60.57	2.81	-72.01	90.05	-73.42	110.35	-76.17	128.78	-74.05	143.08	-65.51	151.45
400	-27.72	170.96	-59.52	2.81	-71.06	90.05	-72.48	110.35	-75.12	128.78	-73.00	143.08	-64.45	151.45
500	-27.72	170.96	-58.89	2.81	-71.95	90.05	-73.37	110.35	-74.48	128.78	-72.36	143.08	-63.82	151.45
600	-27.72	170.96	-58.46	2.81	-72.54	90.05	-73.96	110.35	-74.06	128.78	-71.94	143.08	-63.40	151.45
700	-27.72	170.96	-58.16	2.81	-72.96	90.05	-74.38	110.35	-73.76	128.78	-71.64	143.08	-63.10	151.45
800	-27.72	170.96	-57.94	2.81	-73.27	90.05	-74.69	110.35	-73.53	128.78	-71.41	143.08	-62.87	151.45
900	-27.72	170.96	-57.76	2.81	-73.52	90.05	-74.93	110.35	-73.36	128.78	-71.24	143.08	-62.70	151.45
1000	-27.72	170.96	-57.62	2.81	-73.71	90.05	-75.13	110.35	-73.22	128.78	-71.10	143.08	-62.56	151.45
1200	-27.72	170.96	-57.41	2.81	-74.00	90.05	-75.42	110.35	-73.01	128.78	-70.89	143.08	-62.34	151.45
1500	-27.72	170.96	-57.20	2.81	-74.29	90.05	-75.71	110.35	-72.80	128.78	-70.67	143.08	-62.13	151.45
2000	-27.72	170.96	-56.99	2.81	-74.58	90.05	-76.00	110.35	-72.59	128.78	-70.46	143.08	-61.92	151.45
5000	-27.72	170.96	-57.08	2.81	-75.10	90.05	-76.52	110.35	-72.68	128.78	-70.56	143.08	-62.22	151.45
10000	-27.72	170.96	-57.18	2.81	-75.27	90.05	-76.69	110.35	-72.78	128.78	-70.66	143.08	-62.35	151.45
50000	-27.72	170.96	-57.26	2.81	-75.41	90.05	-76.83	110.35	-72.86	128.78	-70.73	143.08	-62.46	151.45
Tangent	-27.72	170.96	-57.28	2.81	-75.45	90.05	-76.86	110.35	-72.87	128.78	-70.75	143.08	-62.49	151.45

NOTES:

Coordinates shown are in english units (mm)

Maximum values for each radius are shown in Bold Italicized font

All coordinates shown are referenced from a point located at 1/2 track gauge and top of rail (0,0)

Superelevation is applied relative to top of low rail

Points R1_{CEN}, P3_{CEN}, P6_{CEN} and P9_{CEN} are not specific to either Outside or Inside of curve

B# = LFLRV Body Points

M# = LFLRV Mirror Points

P# = LFLRV Pantograph Points

R# = LFLRV Roll Center Point

File Name: MIN-S.XLS
Revision By: SCA
Revision Date: 02/22/99

RADIUS FEET	P9 _{CEN}		P1 _{IN}		P2 _{IN}		P4 _{IN}		P5 _{IN}		P7 _{IN}		P8 _{IN}	
	X	Y	X	Y	X	Y	X	Y	X	Y	X	Y	X	Y
82	-42.12	270.21	-63.00	148.63	-49.61	158.47	-64.85	161.38	-51.46	171.22	-79.26	260.63	-65.87	270.46
100	-42.12	270.21	-63.00	148.63	-49.61	158.47	-64.85	161.38	-51.46	171.22	-79.26	260.63	-65.87	270.46
150	-42.12	270.21	-63.00	148.63	-49.61	158.47	-64.85	161.38	-51.46	171.22	-79.26	260.63	-65.87	270.46
200	-42.12	270.21	-63.00	148.63	-49.61	158.47	-64.85	161.38	-51.46	171.22	-79.26	260.63	-65.87	270.46
300	-42.12	270.21	-63.00	148.63	-49.61	158.47	-64.85	161.38	-51.46	171.22	-79.26	260.63	-65.87	270.46
400	-42.12	270.21	-63.00	148.63	-49.61	158.47	-64.85	161.38	-51.46	171.22	-79.26	260.63	-65.87	270.46
500	-42.12	270.21	-63.00	148.63	-49.61	158.47	-64.85	161.38	-51.46	171.22	-79.26	260.63	-65.87	270.46
600	-42.12	270.21	-63.00	148.63	-49.61	158.47	-64.85	161.38	-51.46	171.22	-79.26	260.63	-65.87	270.46
700	-42.12	270.21	-63.00	148.63	-49.61	158.47	-64.85	161.38	-51.46	171.22	-79.26	260.63	-65.87	270.46
800	-42.12	270.21	-63.00	148.63	-49.61	158.47	-64.85	161.38	-51.46	171.22	-79.26	260.63	-65.87	270.46
900	-42.12	270.21	-63.00	148.63	-49.61	158.47	-64.85	161.38	-51.46	171.22	-79.26	260.63	-65.87	270.46
1000	-42.12	270.21	-63.00	148.63	-49.61	158.47	-64.85	161.38	-51.46	171.22	-79.26	260.63	-65.87	270.46
1200	-42.12	270.21	-63.00	148.63	-49.61	158.47	-64.85	161.38	-51.46	171.22	-79.26	260.63	-65.87	270.46
1500	-42.12	270.21	-63.00	148.63	-49.61	158.47	-64.85	161.38	-51.46	171.22	-79.26	260.63	-65.87	270.46
2000	-42.12	270.21	-63.00	148.63	-49.61	158.47	-64.85	161.38	-51.46	171.22	-79.26	260.63	-65.87	270.46
5000	-42.12	270.21	-63.00	148.63	-49.61	158.47	-64.85	161.38	-51.46	171.22	-79.26	260.63	-65.87	270.46
10000	-42.12	270.21	-63.00	148.63	-49.61	158.47	-64.85	161.38	-51.46	171.22	-79.26	260.63	-65.87	270.46
50000	-42.12	270.21	-63.00	148.63	-49.61	158.47	-64.85	161.38	-51.46	171.22	-79.26	260.63	-65.87	270.46
Tangent	-42.12	270.21	-63.00	148.63	-49.61	158.47	-64.85	161.38	-51.46	171.22	-79.26	260.63	-65.87	270.46

Met Council PROPOSED LOW FLOOR LIGHT RAIL VEHICLE

TABLE 6A - VEHICLE DYNAMIC ENVELOPE - OUTSIDE OF CURVE

Cross Level Variation = 0.5 in
Superelevation = 5.0 in

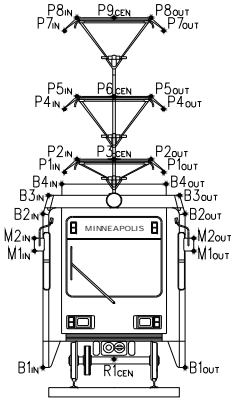

RADIUS FEET	R1 _{CEN}		B1 _{OUT}		M1 _{OUT}		M2 _{OUT}		B2 _{OUT}		B3 _{OUT}		B4 _{OUT}	
	X	Y	X	Y	X	Y	X	Y	X	Y	X	Y	X	Y
82	-1.52	17.70	75.08	11.17	79.85	100.30	79.79	118.45	74.05	135.71	60.31	149.18	55.08	155.94
100	-1.52	17.70	71.18	11.17	76.81	100.30	76.75	118.45	70.16	135.71	58.62	149.18	52.61	155.94
150	-1.52	17.70	64.97	11.17	71.91	100.30	71.85	118.45	63.95	135.71	55.91	149.18	48.68	155.94
200	-1.52	17.70	61.74	11.17	69.34	100.30	69.28	118.45	60.71	135.71	54.47	149.18	46.63	155.94
300	-1.52	17.70	58.42	11.17	66.68	100.30	66.62	118.45	57.39	135.71	52.99	149.18	44.55	155.94
400	-1.52	17.70	57.59	11.17	65.32	100.30	65.26	118.45	56.56	135.71	52.23	149.18	43.48	155.94
500	-1.52	17.70	57.13	11.17	64.49	100.30	64.44	118.45	56.10	135.71	51.77	149.18	42.84	155.94
600	-1.52	17.70	56.82	11.17	63.94	100.30	63.88	118.45	55.79	135.71	51.46	149.18	42.41	155.94
700	-1.52	17.70	56.60	11.17	63.54	100.30	63.48	118.45	55.57	135.71	51.23	149.18	42.10	155.94
800	-1.52	17.70	56.43	11.17	63.24	100.30	63.18	118.45	55.40	135.71	51.07	149.18	41.87	155.94
900	-1.52	17.70	56.30	11.17	63.01	100.30	62.95	118.45	55.27	135.71	50.94	149.18	41.68	155.94
1000	-1.52	17.70	56.19	11.17	62.82	100.30	62.76	118.45	55.16	135.71	50.83	149.18	41.54	155.94
1200	-1.52	17.70	56.04	11.17	62.54	100.30	62.48	118.45	55.01	135.71	50.67	149.18	41.32	155.94
1500	-1.52	17.70	55.88	11.17	62.26	100.30	62.20	118.45	54.85	135.71	50.51	149.18	41.10	155.94
2000	-1.52	17.70	55.72	11.17	61.97	100.30	61.91	118.45	54.69	135.71	50.35	149.18	40.88	155.94
5000	-1.52	17.70	55.43	11.17	61.46	100.30	61.40	118.45	54.40	135.71	50.07	149.18	40.49	155.94
10000	-1.52	17.70	55.34	11.17	61.29	100.30	61.23	118.45	54.31	135.71	49.97	149.18	40.35	155.94
50000	-1.52	17.70	55.26	11.17	61.15	100.30	61.09	118.45	54.23	135.71	49.89	149.18	40.25	155.94
Tangent	-1.52	17.70	55.24	11.17	61.12	100.30	61.06	118.45	54.21	135.71	49.87	149.18	40.22	155.94

NOTES:

Coordinates shown are in english units (mm)

Maximum values for each radius are shown in Bold Italicized font

All coordinates shown are referenced from a point located at 1/2 track gauge and top of rail (0,0)

Superelevation is applied relative to top of low rail

Points R1_{CEN}, P3_{CEN}, P6_{CEN} and P9_{CEN} are not specific to either Outside or Inside of curve

B# = LFLRV Body Points

M# = LFLRV Mirror Points

P# = LFLRV Pantograph Points

R# = LFLRV Roll Center Point

File Name: MIN-S.XLS
Revision By: SCA
Revision Date: 02/22/99

RADIUS FEET	P3 _{CEN}		P1 _{OUT}		P2 _{OUT}		P4 _{OUT}		P5 _{OUT}		P7 _{OUT}		P8 _{OUT}	
	X	Y	X	Y	X	Y	X	Y	X	Y	X	Y	X	Y
82	-28.50	158.70	41.17	153.26	26.11	160.70	41.09	165.84	26.03	173.30	40.50	263.79	25.44	271.81
100	-28.50	158.70	41.17	153.26	26.11	160.70	41.09	165.84	26.03	173.30	40.50	263.79	25.44	271.81
150	-28.50	158.70	41.17	153.26	26.11	160.70	41.09	165.84	26.03	173.30	40.50	263.79	25.44	271.81
200	-28.50	158.70	41.17	153.26	26.11	160.70	41.09	165.84	26.03	173.30	40.50	263.79	25.44	271.81
300	-28.50	158.70	41.17	153.26	26.11	160.70	41.09	165.84	26.03	173.30	40.50	263.79	25.44	271.81
400	-28.50	158.70	41.17	153.26	26.11	160.70	41.09	165.84	26.03	173.30	40.50	263.79	25.44	271.81
500	-28.50	158.70	41.17	153.26	26.11	160.70	41.09	165.84	26.03	173.30	40.50	263.79	25.44	271.81
600	-28.50	158.70	41.17	153.26	26.11	160.70	41.09	165.84	26.03	173.30	40.50	263.79	25.44	271.81
700	-28.50	158.70	41.17	153.26	26.11	160.70	41.09	165.84	26.03	173.30	40.50	263.79	25.44	271.81
800	-28.50	158.70	41.17	153.26	26.11	160.70	41.09	165.84	26.03	173.30	40.50	263.79	25.44	271.81
900	-28.50	158.70	41.17	153.26	26.11	160.70	41.09	165.84	26.03	173.30	40.50	263.79	25.44	271.81
1000	-28.50	158.70	41.17	153.26	26.11	160.70	41.09	165.84	26.03	173.30	40.50	263.79	25.44	271.81
1200	-28.50	158.70	41.17	153.26	26.11	160.70	41.09	165.84	26.03	173.30	40.50	263.79	25.44	271.81
1500	-28.50	158.70	41.17	153.26	26.11	160.70	41.09	165.84	26.03	173.30	40.50	263.79	25.44	271.81
2000	-28.50	158.70	41.17	153.26	26.11	160.70	41.09	165.84	26.03	173.30	40.50	263.79	25.44	271.81
5000	-28.50	158.70	41.17	153.26	26.11	160.70	41.09	165.84	26.03	173.30	40.50	263.79	25.44	271.81
10000	-28.50	158.70	41.17	153.26	26.11	160.70	41.09	165.84	26.03	173.30	40.50	263.79	25.44	271.81
50000	-28.50	158.70	41.17	153.26	26.11	160.70	41.09	165.84	26.03	173.30	40.50	263.79	25.44	271.81
Tangent	-28.50	158.70	41.17	153.26	26.11	160.70	41.09	165.84	26.03	173.30	40.50	263.79	25.44	271.81

Met Council PROPOSED LOW FLOOR LIGHT RAIL VEHICLE

TABLE 6B - VEHICLE DYNAMIC ENVELOPE - INSIDE OF CURVE

Cross Level Variation = 0.5 in
Superelevation = 5.0 in

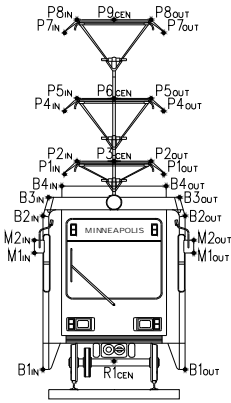

NOTES:

Coordinates shown are in english units (mm)

Maximum values for each radius are shown in Bold Italicized font

All coordinates shown are referenced from a point located at 1/2 track gauge and top of rail (0,0)

Superelevation is applied relative to top of low rail

Points R1_{CEN}, P3_{CEN}, P6_{CEN} and P9_{CEN} are not specific to either Outside or Inside of curve

B# = LFLRV Body Points

M# = LFLRV Mirror Points

P# = LFLRV Pantograph Points

R# = LFLRV Roll Center Point

File Name: MIN-S.XLS
Revision By: SCA
Revision Date: 02/22/99

RADIUS FEET	P6 _{CEN}		B1 _{IN}		M1 _{IN}		M2 _{IN}		B2 _{IN}		B3 _{IN}		B4 _{IN}	
	X	Y	X	Y	X	Y	X	Y	X	Y	X	Y	X	Y
82	-30.56	171.45	-72.08	2.43	-84.86	89.34	-86.43	109.85	-89.51	128.38	-87.63	142.76	-79.26	151.29
100	-30.56	171.45	-69.25	2.43	-82.02	89.34	-83.60	109.85	-86.67	128.38	-84.80	142.76	-76.43	151.29
150	-30.56	171.45	-64.98	2.43	-77.76	89.34	-79.33	109.85	-82.41	128.38	-80.54	142.76	-72.16	151.29
200	-30.56	171.45	-62.86	2.43	-75.64	89.34	-77.21	109.85	-80.29	128.38	-78.41	142.76	-70.04	151.29
300	-30.56	171.45	-60.75	2.43	-73.52	89.34	-75.10	109.85	-78.17	128.38	-76.30	142.76	-67.92	151.29
400	-30.56	171.45	-59.69	2.43	-72.57	89.34	-74.15	109.85	-77.12	128.38	-75.24	142.76	-66.87	151.29
500	-30.56	171.45	-59.06	2.43	-73.47	89.34	-75.04	109.85	-76.48	128.38	-74.61	142.76	-66.24	151.29
600	-30.56	171.45	-58.64	2.43	-74.06	89.34	-75.63	109.85	-76.06	128.38	-74.19	142.76	-65.81	151.29
700	-30.56	171.45	-58.34	2.43	-74.48	89.34	-76.05	109.85	-75.76	128.38	-73.89	142.76	-65.51	151.29
800	-30.56	171.45	-58.11	2.43	-74.79	89.34	-76.37	109.85	-75.53	128.38	-73.66	142.76	-65.29	151.29
900	-30.56	171.45	-57.93	2.43	-75.03	89.34	-76.61	109.85	-75.36	128.38	-73.49	142.76	-65.11	151.29
1000	-30.56	171.45	-57.79	2.43	-75.23	89.34	-76.80	109.85	-75.22	128.38	-73.34	142.76	-64.97	151.29
1200	-30.56	171.45	-57.58	2.43	-75.52	89.34	-77.09	109.85	-75.01	128.38	-73.13	142.76	-64.76	151.29
1500	-30.56	171.45	-57.37	2.43	-75.81	89.34	-77.38	109.85	-74.80	128.38	-72.92	142.76	-64.55	151.29
2000	-30.56	171.45	-57.16	2.43	-76.10	89.34	-77.67	109.85	-74.58	128.38	-72.71	142.76	-64.34	151.29
5000	-30.56	171.45	-57.26	2.43	-76.62	89.34	-78.19	109.85	-74.68	128.38	-72.81	142.76	-64.63	151.29
10000	-30.56	171.45	-57.35	2.43	-76.79	89.34	-78.36	109.85	-74.78	128.38	-72.90	142.76	-64.77	151.29
50000	-30.56	171.45	-57.43	2.43	-76.93	89.34	-78.50	109.85	-74.85	128.38	-72.98	142.76	-64.87	151.29
Tangent	-30.56	171.45	-57.45	2.43	-76.96	89.34	-78.54	109.85	-74.87	128.38	-73.00	142.76	-64.90	151.29

RADIUS FEET	P9 _{CEN}		P1 _{IN}		P2 _{IN}		P4 _{IN}		P5 _{IN}		P7 _{IN}		P8 _{IN}	
	X	Y	X	Y	X	Y	X	Y	X	Y	X	Y	X	Y
82	-46.61	270.69	-65.36	148.46	-52.18	158.55	-67.43	161.21	-54.24	171.30	-83.48	260.46	-70.30	270.55
100	-46.61	270.69	-65.36	148.46	-52.18	158.55	-67.43	161.21	-54.24	171.30	-83.48	260.46	-70.30	270.55
150	-46.61	270.69	-65.36	148.46	-52.18	158.55	-67.43	161.21	-54.24	171.30	-83.48	260.46	-70.30	270.55
200	-46.61	270.69	-65.36	148.46	-52.18	158.55	-67.43	161.21	-54.24	171.30	-83.48	260.46	-70.30	270.55
300	-46.61	270.69	-65.36	148.46	-52.18	158.55	-67.43	161.21	-54.24	171.30	-83.48	260.46	-70.30	270.55
400	-46.61	270.69	-65.36	148.46	-52.18	158.55	-67.43	161.21	-54.24	171.30	-83.48	260.46	-70.30	270.55
500	-46.61	270.69	-65.36	148.46	-52.18	158.55	-67.43	161.21	-54.24	171.30	-83.48	260.46	-70.30	270.55
600	-46.61	270.69	-65.36	148.46	-52.18	158.55	-67.43	161.21	-54.24	171.30	-83.48	260.46	-70.30	270.55
700	-46.61	270.69	-65.36	148.46	-52.18	158.55	-67.43	161.21	-54.24	171.30	-83.48	260.46	-70.30	270.55
800	-46.61	270.69	-65.36	148.46	-52.18	158.55	-67.43	161.21	-54.24	171.30	-83.48	260.46	-70.30	270.55
900	-46.61	270.69	-65.36	148.46	-52.18	158.55	-67.43	161.21	-54.24	171.30	-83.48	260.46	-70.30	270.55
1000	-46.61	270.69	-65.36	148.46	-52.18	158.55	-67.43	161.21	-54.24	171.30	-83.48	260.46	-70.30	270.55
1200	-46.61	270.69	-65.36	148.46	-52.18	158.55	-67.43	161.21	-54.24	171.30	-83.48	260.46	-70.30	270.55
1500	-46.61	270.69	-65.36	148.46	-52.18	158.55	-67.43	161.21	-54.24	171.30	-83.48	260.46	-70.30	270.55
2000	-46.61	270.69	-65.36	148.46	-52.18	158.55	-67.43	161.21	-54.24	171.30	-83.48	260.46	-70.30	270.55
5000	-46.61	270.69	-65.36	148.46	-52.18	158.55	-67.43	161.21	-54.24	171.30	-83.48	260.46	-70.30	270.55
10000	-46.61	270.69	-65.36	148.46	-52.18	158.55	-67.43	161.21	-54.24	171.30	-83.48	260.46	-70.30	270.55
50000	-46.61	270.69	-65.36	148.46	-52.18	158.55	-67.43	161.21	-54.24	171.30	-83.48	260.46	-70.30	270.55
Tangent	-46.61	270.69	-65.36	148.46	-52.18	158.55	-67.43	161.21	-54.24	171.30	-83.48	260.46	-70.30	270.55

Met Council PROPOSED LOW FLOOR LIGHT RAIL VEHICLE

TABLE 7A - VEHICLE DYNAMIC ENVELOPE - OUTSIDE OF CURVE

Cross Level Variation = 0.5 in
Superelevation = 6.0 in

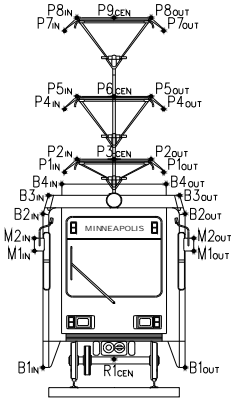

RADIUS FEET	R1 _{CEN}		B1 _{OUT}		M1 _{OUT}		M2 _{OUT}		B2 _{OUT}		B3 _{OUT}		B4 _{OUT}	
	X	Y	X	Y	X	Y	X	Y	X	Y	X	Y	X	Y
82	-1.82	18.17	74.79	12.53	78.15	101.73	77.93	119.62	71.89	136.72	57.91	150.09	52.54	156.66
100	-1.82	18.17	70.89	12.53	75.11	101.73	74.89	119.62	67.99	136.72	56.22	150.09	50.06	156.66
150	-1.82	18.17	64.68	12.53	70.22	101.73	70.00	119.62	61.78	136.72	53.50	150.09	46.13	156.66
200	-1.82	18.17	61.45	12.53	67.65	101.73	67.42	119.62	58.55	136.72	52.07	150.09	44.09	156.66
300	-1.82	18.17	58.13	12.53	64.99	101.73	64.77	119.62	55.23	136.72	50.59	150.09	42.00	156.66
400	-1.82	18.17	57.29	12.53	63.63	101.73	63.41	119.62	54.40	136.72	49.83	150.09	40.94	156.66
500	-1.82	18.17	56.83	12.53	62.80	101.73	62.58	119.62	53.94	136.72	49.37	150.09	40.30	156.66
600	-1.82	18.17	56.52	12.53	62.25	101.73	62.03	119.62	53.63	136.72	49.06	150.09	39.87	156.66
700	-1.82	18.17	56.30	12.53	61.85	101.73	61.63	119.62	53.41	136.72	48.83	150.09	39.56	156.66
800	-1.82	18.17	56.13	12.53	61.55	101.73	61.33	119.62	53.24	136.72	48.66	150.09	39.32	156.66
900	-1.82	18.17	56.00	12.53	61.32	101.73	61.09	119.62	53.11	136.72	48.53	150.09	39.14	156.66
1000	-1.82	18.17	55.90	12.53	61.13	101.73	60.91	119.62	53.00	136.72	48.43	150.09	39.00	156.66
1200	-1.82	18.17	55.74	12.53	60.85	101.73	60.63	119.62	52.84	136.72	48.27	150.09	38.78	156.66
1500	-1.82	18.17	55.58	12.53	60.56	101.73	60.34	119.62	52.69	136.72	48.11	150.09	38.56	156.66
2000	-1.82	18.17	55.42	12.53	60.28	101.73	60.06	119.62	52.53	136.72	47.95	150.09	38.34	156.66
5000	-1.82	18.17	55.14	12.53	59.77	101.73	59.55	119.62	52.24	136.72	47.67	150.09	37.95	156.66
10000	-1.82	18.17	55.04	12.53	59.60	101.73	59.38	119.62	52.14	136.72	47.57	150.09	37.81	156.66
50000	-1.82	18.17	54.96	12.53	59.46	101.73	59.24	119.62	52.07	136.72	47.49	150.09	37.71	156.66
Tangent	-1.82	18.17	54.94	12.53	59.43	101.73	59.20	119.62	52.05	136.72	47.47	150.09	37.68	156.66

NOTES:

Coordinates shown are in english units (mm)

Maximum values for each radius are shown in Bold Italicized font

All coordinates shown are referenced from a point located at 1/2 track gauge and top of rail (0,0)

Superelevation is applied relative to top of low rail

Points R1_{CEN}, P3_{CEN}, P6_{CEN} and P9_{CEN} are not specific to either Outside or Inside of curve

B# = LFLRV Body Points

M# = LFLRV Mirror Points

P# = LFLRV Pantograph Points

R# = LFLRV Roll Center Point

File Name: MIN-S.XLS
Revision By: SCA
Revision Date: 02/22/99

RADIUS FEET	P3 _{CEN}		P1 _{OUT}		P2 _{OUT}		P4 _{OUT}		P5 _{OUT}		P7 _{OUT}		P8 _{OUT}	
	X	Y	X	Y	X	Y	X	Y	X	Y	X	Y	X	Y
82	-31.12	159.14	38.67	154.00	23.45	161.20	38.39	166.54	23.16	173.78	36.13	264.28	20.91	272.31
100	-31.12	159.14	38.67	154.00	23.45	161.20	38.39	166.54	23.16	173.78	36.13	264.28	20.91	272.31
150	-31.12	159.14	38.67	154.00	23.45	161.20	38.39	166.54	23.16	173.78	36.13	264.28	20.91	272.31
200	-31.12	159.14	38.67	154.00	23.45	161.20	38.39	166.54	23.16	173.78	36.13	264.28	20.91	272.31
300	-31.12	159.14	38.67	154.00	23.45	161.20	38.39	166.54	23.16	173.78	36.13	264.28	20.91	272.31
400	-31.12	159.14	38.67	154.00	23.45	161.20	38.39	166.54	23.16	173.78	36.13	264.28	20.91	272.31
500	-31.12	159.14	38.67	154.00	23.45	161.20	38.39	166.54	23.16	173.78	36.13	264.28	20.91	272.31
600	-31.12	159.14	38.67	154.00	23.45	161.20	38.39	166.54	23.16	173.78	36.13	264.28	20.91	272.31
700	-31.12	159.14	38.67	154.00	23.45	161.20	38.39	166.54	23.16	173.78	36.13	264.28	20.91	272.31
800	-31.12	159.14	38.67	154.00	23.45	161.20	38.39	166.54	23.16	173.78	36.13	264.28	20.91	272.31
900	-31.12	159.14	38.67	154.00	23.45	161.20	38.39	166.54	23.16	173.78	36.13	264.28	20.91	272.31
1000	-31.12	159.14	38.67	154.00	23.45	161.20	38.39	166.54	23.16	173.78	36.13	264.28	20.91	272.31
1200	-31.12	159.14	38.67	154.00	23.45	161.20	38.39	166.54	23.16	173.78	36.13	264.28	20.91	272.31
1500	-31.12	159.14	38.67	154.00	23.45	161.20	38.39	166.54	23.16	173.78	36.13	264.28	20.91	272.31
2000	-31.12	159.14	38.67	154.00	23.45	161.20	38.39	166.54	23.16	173.78	36.13	264.28	20.91	272.31
5000	-31.12	159.14	38.67	154.00	23.45	161.20	38.39	166.54	23.16	173.78	36.13	264.28	20.91	272.31
10000	-31.12	159.14	38.67	154.00	23.45	161.20	38.39	166.54	23.16	173.78	36.13	264.28	20.91	272.31
50000	-31.12	159.14	38.67	154.00	23.45	161.20	38.39	166.54	23.16	173.78	36.13	264.28	20.91	272.31
Tangent	-31.12	159.14	38.67	154.00	23.45	161.20	38.39	166.54	23.16	173.78	36.13	264.28	20.91	272.31

Met Council PROPOSED LOW FLOOR LIGHT RAIL VEHICLE

TABLE 7B - VEHICLE DYNAMIC ENVELOPE - INSIDE OF CURVE

Cross Level Variation = 0.5 in
Superelevation = 6.0 in

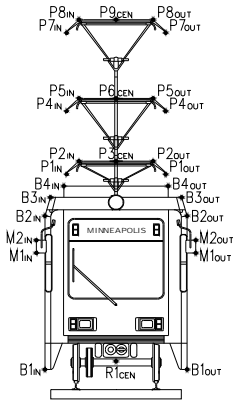

RADIUS FEET	P6 _{CEN}		B1 _{IN}		M1 _{IN}		M2 _{IN}		B2 _{IN}		B3 _{IN}		B4 _{IN}	
	X	Y	X	Y	X	Y	X	Y	X	Y	X	Y	X	Y
82	-33.40	171.88	-72.25	2.05	-86.35	88.61	-88.09	109.31	-91.49	127.95	-89.86	142.39	-81.66	151.09
100	-33.40	171.88	-69.42	2.05	-83.52	88.61	-85.26	109.31	-88.66	127.95	-87.03	142.39	-78.82	151.09
150	-33.40	171.88	-65.15	2.05	-79.25	88.61	-80.99	109.31	-84.39	127.95	-82.77	142.39	-74.56	151.09
200	-33.40	171.88	-63.03	2.05	-77.13	88.61	-78.87	109.31	-82.27	127.95	-80.65	142.39	-72.44	151.09
300	-33.40	171.88	-60.91	2.05	-75.02	88.61	-76.76	109.31	-80.15	127.95	-78.53	142.39	-70.32	151.09
400	-33.40	171.88	-59.86	2.05	-74.07	88.61	-75.81	109.31	-79.10	127.95	-77.47	142.39	-69.27	151.09
500	-33.40	171.88	-59.23	2.05	-74.96	88.61	-76.70	109.31	-78.46	127.95	-76.84	142.39	-68.63	151.09
600	-33.40	171.88	-58.80	2.05	-75.55	88.61	-77.29	109.31	-78.04	127.95	-76.42	142.39	-68.21	151.09
700	-33.40	171.88	-58.50	2.05	-75.97	88.61	-77.71	109.31	-77.74	127.95	-76.12	142.39	-67.91	151.09
800	-33.40	171.88	-58.28	2.05	-76.29	88.61	-78.03	109.31	-77.52	127.95	-75.89	142.39	-67.68	151.09
900	-33.40	171.88	-58.10	2.05	-76.53	88.61	-78.27	109.31	-77.34	127.95	-75.72	142.39	-67.51	151.09
1000	-33.40	171.88	-57.96	2.05	-76.72	88.61	-78.46	109.31	-77.20	127.95	-75.57	142.39	-67.37	151.09
1200	-33.40	171.88	-57.75	2.05	-77.02	88.61	-78.75	109.31	-76.99	127.95	-75.36	142.39	-67.16	151.09
1500	-33.40	171.88	-57.54	2.05	-77.31	88.61	-79.04	109.31	-76.78	127.95	-75.15	142.39	-66.95	151.09
2000	-33.40	171.88	-57.33	2.05	-77.59	88.61	-79.33	109.31	-76.57	127.95	-74.94	142.39	-66.74	151.09
5000	-33.40	171.88	-57.42	2.05	-78.11	88.61	-79.85	109.31	-76.66	127.95	-75.04	142.39	-67.03	151.09
10000	-33.40	171.88	-57.52	2.05	-78.29	88.61	-80.02	109.31	-76.76	127.95	-75.13	142.39	-67.16	151.09
50000	-33.40	171.88	-57.60	2.05	-78.42	88.61	-80.16	109.31	-76.84	127.95	-75.21	142.39	-67.27	151.09
Tangent	-33.40	171.88	-57.62	2.05	-78.46	88.61	-80.20	109.31	-76.86	127.95	-75.23	142.39	-67.30	151.09

NOTES:

Coordinates shown are in english units (mm)

Maximum values for each radius are shown in Bold Italicized font

All coordinates shown are referenced from a point located at 1/2 track gauge and top of rail (0,0)

Superelevation is applied relative to top of low rail

Points R1_{CEN}, P3_{CEN}, P6_{CEN} and P9_{CEN} are not specific to either Outside or Inside of curve

B# = LFLRV Body Points

M# = LFLRV Mirror Points

P# = LFLRV Pantograph Points

R# = LFLRV Roll Center Point

File Name: MIN-S.XLS

Revision By: SCA

Revision Date: 02/22/99

RADIUS FEET	P9 _{CEN}		P1 _{IN}		P2 _{IN}		P4 _{IN}		P5 _{IN}		P7 _{IN}		P8 _{IN}	
	X	Y	X	Y	X	Y	X	Y	X	Y	X	Y	X	Y
82	-51.09	271.11	-67.71	148.25	-54.74	158.59	-69.99	161.00	-57.01	171.34	-87.68	260.22	-74.70	270.56
100	-51.09	271.11	-67.71	148.25	-54.74	158.59	-69.99	161.00	-57.01	171.34	-87.68	260.22	-74.70	270.56
150	-51.09	271.11	-67.71	148.25	-54.74	158.59	-69.99	161.00	-57.01	171.34	-87.68	260.22	-74.70	270.56
200	-51.09	271.11	-67.71	148.25	-54.74	158.59	-69.99	161.00	-57.01	171.34	-87.68	260.22	-74.70	270.56
300	-51.09	271.11	-67.71	148.25	-54.74	158.59	-69.99	161.00	-57.01	171.34	-87.68	260.22	-74.70	270.56
400	-51.09	271.11	-67.71	148.25	-54.74	158.59	-69.99	161.00	-57.01	171.34	-87.68	260.22	-74.70	270.56
500	-51.09	271.11	-67.71	148.25	-54.74	158.59	-69.99	161.00	-57.01	171.34	-87.68	260.22	-74.70	270.56
600	-51.09	271.11	-67.71	148.25	-54.74	158.59	-69.99	161.00	-57.01	171.34	-87.68	260.22	-74.70	270.56
700	-51.09	271.11	-67.71	148.25	-54.74	158.59	-69.99	161.00	-57.01	171.34	-87.68	260.22	-74.70	270.56
800	-51.09	271.11	-67.71	148.25	-54.74	158.59	-69.99	161.00	-57.01	171.34	-87.68	260.22	-74.70	270.56
900	-51.09	271.11	-67.71	148.25	-54.74	158.59	-69.99	161.00	-57.01	171.34	-87.68	260.22	-74.70	270.56
1000	-51.09	271.11	-67.71	148.25	-54.74	158.59	-69.99	161.00	-57.01	171.34	-87.68	260.22	-74.70	270.56
1200	-51.09	271.11	-67.71	148.25	-54.74	158.59	-69.99	161.00	-57.01	171.34	-87.68	260.22	-74.70	270.56
1500	-51.09	271.11	-67.71	148.25	-54.74	158.59	-69.99	161.00	-57.01	171.34	-87.68	260.22	-74.70	270.56
2000	-51.09	271.11	-67.71	148.25	-54.74	158.59	-69.99	161.00	-57.01	171.34	-87.68	260.22	-74.70	270.56
5000	-51.09	271.11	-67.71	148.25	-54.74	158.59	-69.99	161.00	-57.01	171.34	-87.68	260.22	-74.70	270.56
10000	-51.09	271.11	-67.71	148.25	-54.74	158.59	-69.99	161.00	-57.01	171.34	-87.68	260.22	-74.70	270.56
50000	-51.09	271.11	-67.71	148.25	-54.74	158.59	-69.99	161.00	-57.01	171.34	-87.68	260.22	-74.70	270.56
Tangent	-51.09	271.11	-67.71	148.25	-54.74	158.59	-69.99	161.00	-57.01	171.34	-87.68	260.22	-74.70	270.56

Met Council PROPOSED LOW FLOOR LIGHT RAIL VEHICLE

TABLE 8A - VEHICLE DYNAMIC ENVELOPE - OUTSIDE OF CURVE

Cross Level Variation = 1.0 in
Superelevation = 0.0 in

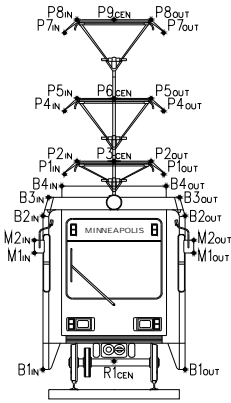

RADIUS FEET	R1 _{CEN}		B1 _{OUT}		M1 _{OUT}		M2 _{OUT}		B2 _{OUT}		B3 _{OUT}		B4 _{OUT}	
	X	Y	X	Y	X	Y	X	Y	X	Y	X	Y	X	Y
82	-0.26	15.50	76.45	3.64	88.76	91.86	89.61	112.73	85.61	130.63	73.21	144.55	68.80	152.14
100	-0.26	15.50	72.56	3.64	85.72	91.86	86.57	112.73	81.71	130.63	71.52	144.55	66.33	152.14
150	-0.26	15.50	66.35	3.64	80.83	91.86	81.67	112.73	75.50	130.63	68.80	144.55	62.39	152.14
200	-0.26	15.50	63.11	3.64	78.25	91.86	79.10	112.73	72.27	130.63	67.37	144.55	60.35	152.14
300	-0.26	15.50	59.80	3.64	75.60	91.86	76.44	112.73	68.95	130.63	65.89	144.55	58.26	152.14
400	-0.26	15.50	58.96	3.64	74.24	91.86	75.08	112.73	68.11	130.63	65.13	144.55	57.20	152.14
500	-0.26	15.50	58.50	3.64	73.41	91.86	74.25	112.73	67.65	130.63	64.67	144.55	56.56	152.14
600	-0.26	15.50	58.19	3.64	72.86	91.86	73.70	112.73	67.35	130.63	64.36	144.55	56.13	152.14
700	-0.26	15.50	57.97	3.64	72.46	91.86	73.30	112.73	67.12	130.63	64.13	144.55	55.82	152.14
800	-0.26	15.50	57.80	3.64	72.16	91.86	73.00	112.73	66.96	130.63	63.96	144.55	55.59	152.14
900	-0.26	15.50	57.67	3.64	71.92	91.86	72.77	112.73	66.82	130.63	63.83	144.55	55.40	152.14
1000	-0.26	15.50	57.57	3.64	71.74	91.86	72.58	112.73	66.72	130.63	63.73	144.55	55.26	152.14
1200	-0.26	15.50	57.41	3.64	71.45	91.86	72.30	112.73	66.56	130.63	63.57	144.55	55.04	152.14
1500	-0.26	15.50	57.25	3.64	71.17	91.86	72.02	112.73	66.40	130.63	63.41	144.55	54.82	152.14
2000	-0.26	15.50	57.09	3.64	70.89	91.86	71.73	112.73	66.24	130.63	63.25	144.55	54.60	152.14
5000	-0.26	15.50	56.80	3.64	70.38	91.86	71.22	112.73	65.96	130.63	62.97	144.55	54.21	152.14
10000	-0.26	15.50	56.71	3.64	70.20	91.86	71.05	112.73	65.86	130.63	62.87	144.55	54.07	152.14
50000	-0.26	15.50	56.63	3.64	70.07	91.86	70.91	112.73	65.78	130.63	62.79	144.55	53.97	152.14
Tangent	-0.26	15.50	56.61	3.64	70.03	91.86	70.88	112.73	65.76	130.63	62.77	144.55	53.94	152.14

NOTES:

Coordinates shown are in english units (mm)

Maximum values for each radius are shown in Bold Italicized font

All coordinates shown are referenced from a point located at 1/2 track gauge and top of rail (0,0)

Superelevation is applied relative to top of low rail

Points R1_{CEN}, P3_{CEN}, P6_{CEN} and P9_{CEN} are not specific to either Outside or Inside of curve

B# = LFLRV Body Points

M# = LFLRV Mirror Points

P# = LFLRV Pantograph Points

R# = LFLRV Roll Center Point

File Name: MIN-S.XLS
Revision By: SCA
Revision Date: 02/22/99

RADIUS FEET	P3 _{CEN}		P1 _{OUT}		P2 _{OUT}		P4 _{OUT}		P5 _{OUT}		P7 _{OUT}		P8 _{OUT}	
	X	Y	X	Y	X	Y	X	Y	X	Y	X	Y	X	Y
82	-16.64	156.48	54.63	149.38	40.55	158.05	55.73	162.08	41.65	170.75	64.32	260.96	50.25	269.63
100	-16.64	156.48	54.63	149.38	40.55	158.05	55.73	162.08	41.65	170.75	64.32	260.96	50.25	269.63
150	-16.64	156.48	54.63	149.38	40.55	158.05	55.73	162.08	41.65	170.75	64.32	260.96	50.25	269.63
200	-16.64	156.48	54.63	149.38	40.55	158.05	55.73	162.08	41.65	170.75	64.32	260.96	50.25	269.63
300	-16.64	156.48	54.63	149.38	40.55	158.05	55.73	162.08	41.65	170.75	64.32	260.96	50.25	269.63
400	-16.64	156.48	54.63	149.38	40.55	158.05	55.73	162.08	41.65	170.75	64.32	260.96	50.25	269.63
500	-16.64	156.48	54.63	149.38	40.55	158.05	55.73	162.08	41.65	170.75	64.32	260.96	50.25	269.63
600	-16.64	156.48	54.63	149.38	40.55	158.05	55.73	162.08	41.65	170.75	64.32	260.96	50.25	269.63
700	-16.64	156.48	54.63	149.38	40.55	158.05	55.73	162.08	41.65	170.75	64.32	260.96	50.25	269.63
800	-16.64	156.48	54.63	149.38	40.55	158.05	55.73	162.08	41.65	170.75	64.32	260.96	50.25	269.63
900	-16.64	156.48	54.63	149.38	40.55	158.05	55.73	162.08	41.65	170.75	64.32	260.96	50.25	269.63
1000	-16.64	156.48	54.63	149.38	40.55	158.05	55.73	162.08	41.65	170.75	64.32	260.96	50.25	269.63
1200	-16.64	156.48	54.63	149.38	40.55	158.05	55.73	162.08	41.65	170.75	64.32	260.96	50.25	269.63
1500	-16.64	156.48	54.63	149.38	40.55	158.05	55.73	162.08	41.65	170.75	64.32	260.96	50.25	269.63
2000	-16.64	156.48	54.63	149.38	40.55	158.05	55.73	162.08	41.65	170.75	64.32	260.96	50.25	269.63
5000	-16.64	156.48	54.63	149.38	40.55	158.05	55.73	162.08	41.65	170.75	64.32	260.96	50.25	269.63
10000	-16.64	156.48	54.63	149.38	40.55	158.05	55.73	162.08	41.65	170.75	64.32	260.96	50.25	269.63
50000	-16.64	156.48	54.63	149.38	40.55	158.05	55.73	162.08	41.65	170.75	64.32	260.96	50.25	269.63
Tangent	-16.64	156.48	54.63	149.38	40.55	158.05	55.73	162.08	41.65	170.75	64.32	260.96	50.25	269.63

Met Council PROPOSED LOW FLOOR LIGHT RAIL VEHICLE

TABLE 8B - VEHICLE DYNAMIC ENVELOPE - INSIDE OF CURVE

Cross Level Variation = 1.0 in
Superelevation = 0.0 in

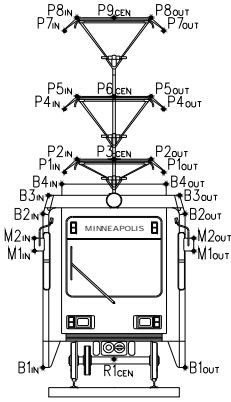

NOTES:

Coordinates shown are in english units (mm)

Maximum values for each radius are shown in Bold Italicized font

All coordinates shown are referenced from a point located at 1/2 track gauge and top of rail (0,0)

Superelevation is applied relative to top of low rail

Points R1_{CEN}, P3_{CEN}, P6_{CEN} and P9_{CEN} are not specific to either Outside or Inside of curve

B# = LFLRV Body Points

M# = LFLRV Mirror Points

P# = LFLRV Pantograph Points

R# = LFLRV Roll Center Point

File Name: MIN-S.XLS

Revision By: SCA

Revision Date: 02/22/99

RADIUS FEET	P6 _{CEN}		B1 _{IN}		M1 _{IN}		M2 _{IN}		B2 _{IN}		B3 _{IN}		B4 _{IN}	
	X	Y	X	Y	X	Y	X	Y	X	Y	X	Y	X	Y
82	-17.74	169.23	-71.25	3.64	-77.93	91.86	-78.77	112.73	-80.40	130.63	-77.41	144.55	-68.30	152.14
100	-17.74	169.23	-68.41	3.64	-75.10	91.86	-75.94	112.73	-77.56	130.63	-74.57	144.55	-65.47	152.14
150	-17.74	169.23	-64.15	3.64	-70.83	91.86	-71.67	112.73	-73.30	130.63	-70.31	144.55	-61.20	152.14
200	-17.74	169.23	-62.03	3.64	-68.71	91.86	-69.55	112.73	-71.18	130.63	-68.19	144.55	-59.08	152.14
300	-17.74	169.23	-59.91	3.64	-66.59	91.86	-67.44	112.73	-69.06	130.63	-66.07	144.55	-56.97	152.14
400	-17.74	169.23	-58.86	3.64	-65.65	91.86	-66.49	112.73	-68.01	130.63	-65.02	144.55	-55.91	152.14
500	-17.74	169.23	-58.22	3.64	-66.54	91.86	-67.38	112.73	-67.37	130.63	-64.38	144.55	-55.28	152.14
600	-17.74	169.23	-57.80	3.64	-67.13	91.86	-67.97	112.73	-66.95	130.63	-63.96	144.55	-54.86	152.14
700	-17.74	169.23	-57.50	3.64	-67.55	91.86	-68.39	112.73	-66.65	130.63	-63.66	144.55	-54.55	152.14
800	-17.74	169.23	-57.27	3.64	-67.86	91.86	-68.71	112.73	-66.42	130.63	-63.43	144.55	-54.33	152.14
900	-17.74	169.23	-57.10	3.64	-68.11	91.86	-68.95	112.73	-66.25	130.63	-63.26	144.55	-54.15	152.14
1000	-17.74	169.23	-56.96	3.64	-68.30	91.86	-69.14	112.73	-66.11	130.63	-63.12	144.55	-54.01	152.14
1200	-17.74	169.23	-56.74	3.64	-68.59	91.86	-69.44	112.73	-65.90	130.63	-62.91	144.55	-53.80	152.14
1500	-17.74	169.23	-56.53	3.64	-68.88	91.86	-69.73	112.73	-65.69	130.63	-62.69	144.55	-53.59	152.14
2000	-17.74	169.23	-56.32	3.64	-69.17	91.86	-70.01	112.73	-65.48	130.63	-62.48	144.55	-53.38	152.14
5000	-17.74	169.23	-56.42	3.64	-69.69	91.86	-70.53	112.73	-65.57	130.63	-62.58	144.55	-53.68	152.14
10000	-17.74	169.23	-56.52	3.64	-69.86	91.86	-70.71	112.73	-65.67	130.63	-62.68	144.55	-53.81	152.14
50000	-17.74	169.23	-56.59	3.64	-70.00	91.86	-70.84	112.73	-65.75	130.63	-62.75	144.55	-53.92	152.14
Tangent	-17.74	169.23	-56.61	3.64	-70.03	91.86	-70.88	112.73	-65.76	130.63	-62.77	144.55	-53.94	152.14

RADIUS FEET	P9 _{CEN}		P1 _{IN}		P2 _{IN}		P4 _{IN}		P5 _{IN}		P7 _{IN}		P8 _{IN}	
	X	Y	X	Y	X	Y	X	Y	X	Y	X	Y	X	Y
82	-26.34	268.46	-54.63	149.38	-40.55	158.05	-55.73	162.08	-41.65	170.75	-64.32	260.96	-50.25	269.63
100	-26.34	268.46	-54.63	149.38	-40.55	158.05	-55.73	162.08	-41.65	170.75	-64.32	260.96	-50.25	269.63
150	-26.34	268.46	-54.63	149.38	-40.55	158.05	-55.73	162.08	-41.65	170.75	-64.32	260.96	-50.25	269.63
200	-26.34	268.46	-54.63	149.38	-40.55	158.05	-55.73	162.08	-41.65	170.75	-64.32	260.96	-50.25	269.63
300	-26.34	268.46	-54.63	149.38	-40.55	158.05	-55.73	162.08	-41.65	170.75	-64.32	260.96	-50.25	269.63
400	-26.34	268.46	-54.63	149.38	-40.55	158.05	-55.73	162.08	-41.65	170.75	-64.32	260.96	-50.25	269.63
500	-26.34	268.46	-54.63	149.38	-40.55	158.05	-55.73	162.08	-41.65	170.75	-64.32	260.96	-50.25	269.63
600	-26.34	268.46	-54.63	149.38	-40.55	158.05	-55.73	162.08	-41.65	170.75	-64.32	260.96	-50.25	269.63
700	-26.34	268.46	-54.63	149.38	-40.55	158.05	-55.73	162.08	-41.65	170.75	-64.32	260.96	-50.25	269.63
800	-26.34	268.46	-54.63	149.38	-40.55	158.05	-55.73	162.08	-41.65	170.75	-64.32	260.96	-50.25	269.63
900	-26.34	268.46	-54.63	149.38	-40.55	158.05	-55.73	162.08	-41.65	170.75	-64.32	260.96	-50.25	269.63
1000	-26.34	268.46	-54.63	149.38	-40.55	158.05	-55.73	162.08	-41.65	170.75	-64.32	260.96	-50.25	269.63
1200	-26.34	268.46	-54.63	149.38	-40.55	158.05	-55.73	162.08	-41.65	170.75	-64.32	260.96	-50.25	269.63
1500	-26.34	268.46	-54.63	149.38	-40.55	158.05	-55.73	162.08	-41.65	170.75	-64.32	260.96	-50.25	269.63
2000	-26.34	268.46	-54.63	149.38	-40.55	158.05	-55.73	162.08	-41.65	170.75	-64.32	260.96	-50.25	269.63
5000	-26.34	268.46	-54.63	149.38	-40.55	158.05	-55.73	162.08	-41.65	170.75	-64.32	260.96	-50.25	269.63
10000	-26.34	268.46	-54.63	149.38	-40.55	158.05	-55.73	162.08	-41.65	170.75	-64.32	260.96	-50.25	269.63
50000	-26.34	268.46	-54.63	149.38	-40.55	158.05	-55.73	162.08	-41.65	170.75	-64.32	260.96	-50.25	269.63
Tangent	-26.34	268.46	-54.63	149.38	-40.55	158.05	-55.73	162.08	-41.65	170.75	-64.32	260.96	-50.25	269.63

Met Council PROPOSED LOW FLOOR LIGHT RAIL VEHICLE

TABLE 9A - VEHICLE DYNAMIC ENVELOPE - OUTSIDE OF CURVE

Cross Level Variation = 1.0 in
Superelevation = 1.0 in

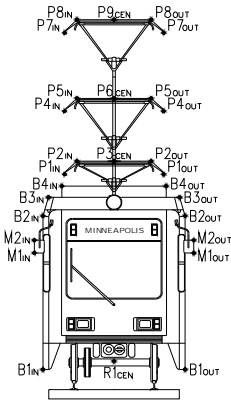

NOTES:

Coordinates shown are in english units (mm)

Maximum values for each radius are shown in Bold Italicized font

All coordinates shown are referenced from a point located at 1/2 track gauge and top of rail (0,0)

Superelevation is applied relative to top of low rail

Points R1_{CEN}, P3_{CEN}, P6_{CEN} and P9_{CEN} are not specific to either Outside or Inside of curve

B# = LFLRV Body Points

M# = LFLRV Mirror Points

P# = LFLRV Pantograph Points

R# = LFLRV Roll Center Point

File Name: MIN-S.XLS
Revision By: SCA
Revision Date: 02/22/99

RADIUS FEET	R1 _{CEN}		B1 _{OUT}		M1 _{OUT}		M2 _{OUT}		B2 _{OUT}		B3 _{OUT}		B4 _{OUT}	
	X	Y	X	Y	X	Y	X	Y	X	Y	X	Y	X	Y
82	-0.52	16.00	76.26	5.01	87.20	93.45	87.88	114.06	83.56	131.82	70.91	145.66	66.35	153.06
100	-0.52	16.00	72.36	5.01	84.16	93.45	84.84	114.06	79.66	131.82	69.23	145.66	63.87	153.06
150	-0.52	16.00	66.15	5.01	79.26	93.45	79.94	114.06	73.45	131.82	66.51	145.66	59.94	153.06
200	-0.52	16.00	62.92	5.01	76.69	93.45	77.37	114.06	70.22	131.82	65.08	145.66	57.90	153.06
300	-0.52	16.00	59.60	5.01	74.03	93.45	74.71	114.06	66.90	131.82	63.59	145.66	55.81	153.06
400	-0.52	16.00	58.77	5.01	72.67	93.45	73.35	114.06	66.07	131.82	62.83	145.66	54.75	153.06
500	-0.52	16.00	58.31	5.01	71.85	93.45	72.53	114.06	65.61	131.82	62.37	145.66	54.11	153.06
600	-0.52	16.00	58.00	5.01	71.29	93.45	71.97	114.06	65.30	131.82	62.06	145.66	53.68	153.06
700	-0.52	16.00	57.77	5.01	70.89	93.45	71.57	114.06	65.07	131.82	61.84	145.66	53.37	153.06
800	-0.52	16.00	57.61	5.01	70.59	93.45	71.27	114.06	64.91	131.82	61.67	145.66	53.13	153.06
900	-0.52	16.00	57.48	5.01	70.36	93.45	71.04	114.06	64.78	131.82	61.54	145.66	52.95	153.06
1000	-0.52	16.00	57.37	5.01	70.17	93.45	70.85	114.06	64.67	131.82	61.43	145.66	52.81	153.06
1200	-0.52	16.00	57.21	5.01	69.89	93.45	70.57	114.06	64.51	131.82	61.28	145.66	52.59	153.06
1500	-0.52	16.00	57.05	5.01	69.61	93.45	70.29	114.06	64.36	131.82	61.12	145.66	52.37	153.06
2000	-0.52	16.00	56.90	5.01	69.32	93.45	70.00	114.06	64.20	131.82	60.96	145.66	52.15	153.06
5000	-0.52	16.00	56.61	5.01	68.81	93.45	69.49	114.06	63.91	131.82	60.67	145.66	51.76	153.06
10000	-0.52	16.00	56.51	5.01	68.64	93.45	69.32	114.06	63.81	131.82	60.57	145.66	51.62	153.06
50000	-0.52	16.00	56.44	5.01	68.50	93.45	69.18	114.06	63.74	131.82	60.50	145.66	51.52	153.06
Tangent	-0.52	16.00	56.42	5.01	68.47	93.45	69.15	114.06	63.72	131.82	60.48	145.66	51.49	153.06

RADIUS FEET	P3 _{CEN}		P1 _{OUT}		P2 _{OUT}		P4 _{OUT}		P5 _{OUT}		P7 _{OUT}		P8 _{OUT}	
	X	Y	X	Y	X	Y	X	Y	X	Y	X	Y	X	Y
82	-19.27	157.00	52.22	150.32	37.96	158.72	53.11	163.00	38.85	171.40	60.04	261.72	45.77	270.12
100	-19.27	157.00	52.22	150.32	37.96	158.72	53.11	163.00	38.85	171.40	60.04	261.72	45.77	270.12
150	-19.27	157.00	52.22	150.32	37.96	158.72	53.11	163.00	38.85	171.40	60.04	261.72	45.77	270.12
200	-19.27	157.00	52.22	150.32	37.96	158.72	53.11	163.00	38.85	171.40	60.04	261.72	45.77	270.12
300	-19.27	157.00	52.22	150.32	37.96	158.72	53.11	163.00	38.85	171.40	60.04	261.72	45.77	270.12
400	-19.27	157.00	52.22	150.32	37.96	158.72	53.11	163.00	38.85	171.40	60.04	261.72	45.77	270.12
500	-19.27	157.00	52.22	150.32	37.96	158.72	53.11	163.00	38.85	171.40	60.04	261.72	45.77	270.12
600	-19.27	157.00	52.22	150.32	37.96	158.72	53.11	163.00	38.85	171.40	60.04	261.72	45.77	270.12
700	-19.27	157.00	52.22	150.32	37.96	158.72	53.11	163.00	38.85	171.40	60.04	261.72	45.77	270.12
800	-19.27	157.00	52.22	150.32	37.96	158.72	53.11	163.00	38.85	171.40	60.04	261.72	45.77	270.12
900	-19.27	157.00	52.22	150.32	37.96	158.72	53.11	163.00	38.85	171.40	60.04	261.72	45.77	270.12
1000	-19.27	157.00	52.22	150.32	37.96	158.72	53.11	163.00	38.85	171.40	60.04	261.72	45.77	270.12
1200	-19.27	157.00	52.22	150.32	37.96	158.72	53.11	163.00	38.85	171.40	60.04	261.72	45.77	270.12
1500	-19.27	157.00	52.22	150.32	37.96	158.72	53.11	163.00	38.85	171.40	60.04	261.72	45.77	270.12
2000	-19.27	157.00	52.22	150.32	37.96	158.72	53.11	163.00	38.85	171.40	60.04	261.72	45.77	270.12
5000	-19.27	157.00	52.22	150.32	37.96	158.72	53.11	163.00	38.85	171.40	60.04	261.72	45.77	270.12
10000	-19.27	157.00	52.22	150.32	37.96	158.72	53.11	163.00	38.85	171.40	60.04	261.72	45.77	270.12
50000	-19.27	157.00	52.22	150.32	37.96	158.72	53.11	163.00	38.85	171.40	60.04	261.72	45.77	270.12
Tangent	-19.27	157.00	52.22	150.32	37.96	158.72	53.11	163.00	38.85	171.40	60.04	261.72	45.77	270.12

Met Council PROPOSED LOW FLOOR LIGHT RAIL VEHICLE

TABLE 9B - VEHICLE DYNAMIC ENVELOPE - INSIDE OF CURVE

Cross Level Variation = 1.0 in
Superelevation = 1.0 in

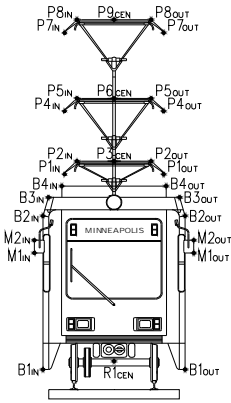

NOTES:

Coordinates shown are in english units (mm)

Maximum values for each radius are shown in Bold Italicized font

All coordinates shown are referenced from a point located at 1/2 track gauge and top of rail (0,0)

Superelevation is applied relative to top of low rail

Points R1_{CEN}, P3_{CEN}, P6_{CEN} and P9_{CEN} are not specific to either Outside or Inside of curve

B# = LFLRV Body Points

M# = LFLRV Mirror Points

P# = LFLRV Pantograph Points

R# = LFLRV Roll Center Point

File Name: MIN-S.XLS
Revision By: SCA
Revision Date: 02/22/99

RADIUS FEET	P6 _{CEN}		B1 _{IN}		M1 _{IN}		M2 _{IN}		B2 _{IN}		B3 _{IN}		B4 _{IN}	
	X	Y	X	Y	X	Y	X	Y	X	Y	X	Y	X	Y
82	-20.59	169.75	-71.44	3.26	-79.49	91.23	-80.50	112.37	-82.45	130.39	-79.70	144.41	-70.76	152.17
100	-20.59	169.75	-68.61	3.26	-76.66	91.23	-77.67	112.37	-79.61	130.39	-76.87	144.41	-67.92	152.17
150	-20.59	169.75	-64.35	3.26	-72.39	91.23	-73.40	112.37	-75.35	130.39	-72.60	144.41	-63.66	152.17
200	-20.59	169.75	-62.22	3.26	-70.27	91.23	-71.28	112.37	-73.23	130.39	-70.48	144.41	-61.54	152.17
300	-20.59	169.75	-60.11	3.26	-68.16	91.23	-69.16	112.37	-71.11	130.39	-68.37	144.41	-59.42	152.17
400	-20.59	169.75	-59.05	3.26	-67.21	91.23	-68.22	112.37	-70.05	130.39	-67.31	144.41	-58.36	152.17
500	-20.59	169.75	-58.42	3.26	-68.10	91.23	-69.11	112.37	-69.42	130.39	-66.68	144.41	-57.73	152.17
600	-20.59	169.75	-58.00	3.26	-68.69	91.23	-69.70	112.37	-69.00	130.39	-66.26	144.41	-57.31	152.17
700	-20.59	169.75	-57.70	3.26	-69.11	91.23	-70.12	112.37	-68.70	130.39	-65.95	144.41	-57.01	152.17
800	-20.59	169.75	-57.47	3.26	-69.43	91.23	-70.43	112.37	-68.47	130.39	-65.73	144.41	-56.78	152.17
900	-20.59	169.75	-57.29	3.26	-69.67	91.23	-70.68	112.37	-68.30	130.39	-65.55	144.41	-56.61	152.17
1000	-20.59	169.75	-57.15	3.26	-69.86	91.23	-70.87	112.37	-68.16	130.39	-65.41	144.41	-56.47	152.17
1200	-20.59	169.75	-56.94	3.26	-70.15	91.23	-71.16	112.37	-67.94	130.39	-65.20	144.41	-56.25	152.17
1500	-20.59	169.75	-56.73	3.26	-70.44	91.23	-71.45	112.37	-67.73	130.39	-64.99	144.41	-56.04	152.17
2000	-20.59	169.75	-56.52	3.26	-70.73	91.23	-71.74	112.37	-67.52	130.39	-64.78	144.41	-55.83	152.17
5000	-20.59	169.75	-56.62	3.26	-71.25	91.23	-72.26	112.37	-67.62	130.39	-64.88	144.41	-56.13	152.17
10000	-20.59	169.75	-56.71	3.26	-71.42	91.23	-72.43	112.37	-67.72	130.39	-64.97	144.41	-56.26	152.17
50000	-20.59	169.75	-56.79	3.26	-71.56	91.23	-72.57	112.37	-67.79	130.39	-65.05	144.41	-56.37	152.17
Tangent	-20.59	169.75	-56.81	3.26	-71.60	91.23	-72.60	112.37	-67.81	130.39	-65.07	144.41	-56.40	152.17

RADIUS FEET	P9 _{CEN}		P1 _{IN}		P2 _{IN}		P4 _{IN}		P5 _{IN}		P7 _{IN}		P8 _{IN}	
	X	Y	X	Y	X	Y	X	Y	X	Y	X	Y	X	Y
82	-30.85	269.00	-57.03	149.40	-43.14	158.33	-58.35	162.12	-44.46	171.05	-68.61	261.13	-54.73	270.06
100	-30.85	269.00	-57.03	149.40	-43.14	158.33	-58.35	162.12	-44.46	171.05	-68.61	261.13	-54.73	270.06
150	-30.85	269.00	-57.03	149.40	-43.14	158.33	-58.35	162.12	-44.46	171.05	-68.61	261.13	-54.73	270.06
200	-30.85	269.00	-57.03	149.40	-43.14	158.33	-58.35	162.12	-44.46	171.05	-68.61	261.13	-54.73	270.06
300	-30.85	269.00	-57.03	149.40	-43.14	158.33	-58.35	162.12	-44.46	171.05	-68.61	261.13	-54.73	270.06
400	-30.85	269.00	-57.03	149.40	-43.14	158.33	-58.35	162.12	-44.46	171.05	-68.61	261.13	-54.73	270.06
500	-30.85	269.00	-57.03	149.40	-43.14	158.33	-58.35	162.12	-44.46	171.05	-68.61	261.13	-54.73	270.06
600	-30.85	269.00	-57.03	149.40	-43.14	158.33	-58.35	162.12	-44.46	171.05	-68.61	261.13	-54.73	270.06
700	-30.85	269.00	-57.03	149.40	-43.14	158.33	-58.35	162.12	-44.46	171.05	-68.61	261.13	-54.73	270.06
800	-30.85	269.00	-57.03	149.40	-43.14	158.33	-58.35	162.12	-44.46	171.05	-68.61	261.13	-54.73	270.06
900	-30.85	269.00	-57.03	149.40	-43.14	158.33	-58.35	162.12	-44.46	171.05	-68.61	261.13	-54.73	270.06
1000	-30.85	269.00	-57.03	149.40	-43.14	158.33	-58.35	162.12	-44.46	171.05	-68.61	261.13	-54.73	270.06
1200	-30.85	269.00	-57.03	149.40	-43.14	158.33	-58.35	162.12	-44.46	171.05	-68.61	261.13	-54.73	270.06
1500	-30.85	269.00	-57.03	149.40	-43.14	158.33	-58.35	162.12	-44.46	171.05	-68.61	261.13	-54.73	270.06
2000	-30.85	269.00	-57.03	149.40	-43.14	158.33	-58.35	162.12	-44.46	171.05	-68.61	261.13	-54.73	270.06
5000	-30.85	269.00	-57.03	149.40	-43.14	158.33	-58.35	162.12	-44.46	171.05	-68.61	261.13	-54.73	270.06
10000	-30.85	269.00	-57.03	149.40	-43.14	158.33	-58.35	162.12	-44.46	171.05	-68.61	261.13	-54.73	270.06
50000	-30.85	269.00	-57.03	149.40	-43.14	158.33	-58.35	162.12	-44.46	171.05	-68.61	261.13	-54.73	270.06
Tangent	-30.85	269.00	-57.03	149.40	-43.14	158.33	-58.35	162.12	-44.46	171.05	-68.61	261.13	-54.73	270.06

Met Council PROPOSED LOW FLOOR LIGHT RAIL VEHICLE

TABLE 10A - VEHICLE DYNAMIC ENVELOPE - OUTSIDE OF CURVE

Cross Level Variation = 1.0 in
Superelevation = 2.0 in

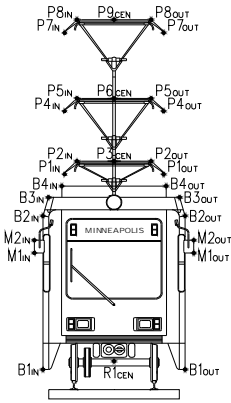

RADIUS FEET	R1 _{CEN}		B1 _{OUT}		M1 _{OUT}		M2 _{OUT}		B2 _{OUT}		B3 _{OUT}		B4 _{OUT}	
	X	Y	X	Y	X	Y	X	Y	X	Y	X	Y	X	Y
82	-0.80	16.50	76.04	6.39	85.61	95.03	86.12	115.36	81.49	132.98	68.59	146.72	63.88	153.94
100	-0.80	16.50	72.14	6.39	82.57	95.03	83.08	115.36	77.59	132.98	66.91	146.72	61.40	153.94
150	-0.80	16.50	65.93	6.39	77.67	95.03	78.19	115.36	71.38	132.98	64.19	146.72	57.47	153.94
200	-0.80	16.50	62.70	6.39	75.10	95.03	75.61	115.36	68.15	132.98	62.76	146.72	55.43	153.94
300	-0.80	16.50	59.38	6.39	72.44	95.03	72.96	115.36	64.83	132.98	61.27	146.72	53.34	153.94
400	-0.80	16.50	58.55	6.39	71.08	95.03	71.60	115.36	63.99	132.98	60.51	146.72	52.28	153.94
500	-0.80	16.50	58.09	6.39	70.26	95.03	70.77	115.36	63.53	132.98	60.05	146.72	51.64	153.94
600	-0.80	16.50	57.78	6.39	69.70	95.03	70.22	115.36	63.22	132.98	59.74	146.72	51.20	153.94
700	-0.80	16.50	57.55	6.39	69.30	95.03	69.82	115.36	63.00	132.98	59.52	146.72	50.90	153.94
800	-0.80	16.50	57.39	6.39	69.00	95.03	69.52	115.36	62.83	132.98	59.35	146.72	50.66	153.94
900	-0.80	16.50	57.26	6.39	68.77	95.03	69.28	115.36	62.70	132.98	59.22	146.72	50.48	153.94
1000	-0.80	16.50	57.15	6.39	68.58	95.03	69.10	115.36	62.60	132.98	59.11	146.72	50.34	153.94
1200	-0.80	16.50	56.99	6.39	68.30	95.03	68.82	115.36	62.44	132.98	58.96	146.72	50.12	153.94
1500	-0.80	16.50	56.83	6.39	68.02	95.03	68.53	115.36	62.28	132.98	58.80	146.72	49.90	153.94
2000	-0.80	16.50	56.68	6.39	67.73	95.03	68.25	115.36	62.12	132.98	58.64	146.72	49.68	153.94
5000	-0.80	16.50	56.39	6.39	67.22	95.03	67.74	115.36	61.84	132.98	58.35	146.72	49.28	153.94
10000	-0.80	16.50	56.29	6.39	67.05	95.03	67.57	115.36	61.74	132.98	58.26	146.72	49.15	153.94
50000	-0.80	16.50	56.22	6.39	66.91	95.03	67.43	115.36	61.66	132.98	58.18	146.72	49.05	153.94
Tangent	-0.80	16.50	56.20	6.39	66.88	95.03	67.39	115.36	61.64	132.98	58.16	146.72	49.02	153.94

NOTES:

Coordinates shown are in english units (mm)

Maximum values for each radius are shown in Bold Italicized font

All coordinates shown are referenced from a point located at 1/2 track gauge and top of rail (0,0)

Superelevation is applied relative to top of low rail

Points R1_{CEN}, P3_{CEN}, P6_{CEN} and P9_{CEN} are not specific to either Outside or Inside of curve

B# = LFLRV Body Points

M# = LFLRV Mirror Points

P# = LFLRV Pantograph Points

R# = LFLRV Roll Center Point

File Name: MIN-S.XLS
Revision By: SCA
Revision Date: 02/22/99

RADIUS FEET	P3 _{CEN}		P1 _{OUT}		P2 _{OUT}		P4 _{OUT}		P5 _{OUT}		P7 _{OUT}		P8 _{OUT}	
	X	Y	X	Y	X	Y	X	Y	X	Y	X	Y	X	Y
82	-21.91	157.48	49.80	151.22	35.35	159.34	50.47	163.87	36.02	172.00	55.73	262.41	41.28	270.63
100	-21.91	157.48	49.80	151.22	35.35	159.34	50.47	163.87	36.02	172.00	55.73	262.41	41.28	270.63
150	-21.91	157.48	49.80	151.22	35.35	159.34	50.47	163.87	36.02	172.00	55.73	262.41	41.28	270.63
200	-21.91	157.48	49.80	151.22	35.35	159.34	50.47	163.87	36.02	172.00	55.73	262.41	41.28	270.63
300	-21.91	157.48	49.80	151.22	35.35	159.34	50.47	163.87	36.02	172.00	55.73	262.41	41.28	270.63
400	-21.91	157.48	49.80	151.22	35.35	159.34	50.47	163.87	36.02	172.00	55.73	262.41	41.28	270.63
500	-21.91	157.48	49.80	151.22	35.35	159.34	50.47	163.87	36.02	172.00	55.73	262.41	41.28	270.63
600	-21.91	157.48	49.80	151.22	35.35	159.34	50.47	163.87	36.02	172.00	55.73	262.41	41.28	270.63
700	-21.91	157.48	49.80	151.22	35.35	159.34	50.47	163.87	36.02	172.00	55.73	262.41	41.28	270.63
800	-21.91	157.48	49.80	151.22	35.35	159.34	50.47	163.87	36.02	172.00	55.73	262.41	41.28	270.63
900	-21.91	157.48	49.80	151.22	35.35	159.34	50.47	163.87	36.02	172.00	55.73	262.41	41.28	270.63
1000	-21.91	157.48	49.80	151.22	35.35	159.34	50.47	163.87	36.02	172.00	55.73	262.41	41.28	270.63
1200	-21.91	157.48	49.80	151.22	35.35	159.34	50.47	163.87	36.02	172.00	55.73	262.41	41.28	270.63
1500	-21.91	157.48	49.80	151.22	35.35	159.34	50.47	163.87	36.02	172.00	55.73	262.41	41.28	270.63
2000	-21.91	157.48	49.80	151.22	35.35	159.34	50.47	163.87	36.02	172.00	55.73	262.41	41.28	270.63
5000	-21.91	157.48	49.80	151.22	35.35	159.34	50.47	163.87	36.02	172.00	55.73	262.41	41.28	270.63
10000	-21.91	157.48	49.80	151.22	35.35	159.34	50.47	163.87	36.02	172.00	55.73	262.41	41.28	270.63
50000	-21.91	157.48	49.80	151.22	35.35	159.34	50.47	163.87	36.02	172.00	55.73	262.41	41.28	270.63
Tangent	-21.91	157.48	49.80	151.22	35.35	159.34	50.47	163.87	36.02	172.00	55.73	262.41	41.28	270.63

Met Council PROPOSED LOW FLOOR LIGHT RAIL VEHICLE

TABLE 10B - VEHICLE DYNAMIC ENVELOPE - INSIDE OF CURVE

Cross Level Variation = 1.0 in
Superelevation = 2.0 in

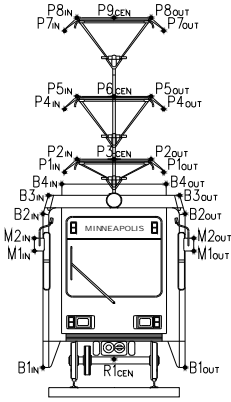

RADIUS FEET	P6 _{CEN}		B1 _{IN}		M1 _{IN}		M2 _{IN}		B2 _{IN}		B3 _{IN}		B4 _{IN}	
	X	Y	X	Y	X	Y	X	Y	X	Y	X	Y	X	Y
82	-23.44	170.23	-71.64	2.88	-81.04	90.58	-82.21	111.97	-84.48	130.12	-81.99	144.22	-73.20	152.16
100	-23.44	170.23	-68.80	2.88	-78.21	90.58	-79.38	111.97	-81.65	130.12	-79.15	144.22	-70.37	152.16
150	-23.44	170.23	-64.54	2.88	-73.94	90.58	-75.11	111.97	-77.38	130.12	-74.89	144.22	-66.10	152.16
200	-23.44	170.23	-62.42	2.88	-71.82	90.58	-72.99	111.97	-75.26	130.12	-72.77	144.22	-63.98	152.16
300	-23.44	170.23	-60.30	2.88	-69.71	90.58	-70.88	111.97	-73.15	130.12	-70.65	144.22	-61.87	152.16
400	-23.44	170.23	-59.24	2.88	-68.76	90.58	-69.93	111.97	-72.09	130.12	-69.60	144.22	-60.81	152.16
500	-23.44	170.23	-58.61	2.88	-69.65	90.58	-70.82	111.97	-71.46	130.12	-68.96	144.22	-60.18	152.16
600	-23.44	170.23	-58.19	2.88	-70.24	90.58	-71.41	111.97	-71.04	130.12	-68.54	144.22	-59.76	152.16
700	-23.44	170.23	-57.89	2.88	-70.66	90.58	-71.83	111.97	-70.73	130.12	-68.24	144.22	-59.45	152.16
800	-23.44	170.23	-57.66	2.88	-70.98	90.58	-72.15	111.97	-70.51	130.12	-68.01	144.22	-59.23	152.16
900	-23.44	170.23	-57.49	2.88	-71.22	90.58	-72.39	111.97	-70.33	130.12	-67.84	144.22	-59.05	152.16
1000	-23.44	170.23	-57.35	2.88	-71.41	90.58	-72.59	111.97	-70.19	130.12	-67.70	144.22	-58.91	152.16
1200	-23.44	170.23	-57.13	2.88	-71.70	90.58	-72.88	111.97	-69.98	130.12	-67.49	144.22	-58.70	152.16
1500	-23.44	170.23	-56.92	2.88	-71.99	90.58	-73.17	111.97	-69.77	130.12	-67.28	144.22	-58.49	152.16
2000	-23.44	170.23	-56.71	2.88	-72.28	90.58	-73.46	111.97	-69.56	130.12	-67.06	144.22	-58.28	152.16
5000	-23.44	170.23	-56.81	2.88	-72.80	90.58	-73.97	111.97	-69.65	130.12	-67.16	144.22	-58.58	152.16
10000	-23.44	170.23	-56.91	2.88	-72.97	90.58	-74.15	111.97	-69.75	130.12	-67.26	144.22	-58.71	152.16
50000	-23.44	170.23	-56.98	2.88	-73.11	90.58	-74.28	111.97	-69.83	130.12	-67.33	144.22	-58.81	152.16
Tangent	-23.44	170.23	-57.00	2.88	-73.15	90.58	-74.32	111.97	-69.85	130.12	-67.35	144.22	-58.84	152.16

NOTES:

Coordinates shown are in english units (mm)

Maximum values for each radius are shown in Bold Italicized font

All coordinates shown are referenced from a point located at 1/2 track gauge and top of rail (0,0)

Superelevation is applied relative to top of low rail

Points R1_{CEN}, P3_{CEN}, P6_{CEN} and P9_{CEN} are not specific to either Outside or Inside of curve

B# = LFLRV Body Points

M# = LFLRV Mirror Points

P# = LFLRV Pantograph Points

R# = LFLRV Roll Center Point

File Name: MIN-S.XLS
Revision By: SCA
Revision Date: 02/22/99

RADIUS FEET	P9 _{CEN}		P1 _{IN}		P2 _{IN}		P4 _{IN}		P5 _{IN}		P7 _{IN}		P8 _{IN}	
	X	Y	X	Y	X	Y	X	Y	X	Y	X	Y	X	Y
82	-35.37	269.46	-59.43	149.38	-45.74	158.57	-60.96	162.11	-47.27	171.30	-72.89	261.22	-59.20	270.41
100	-35.37	269.46	-59.43	149.38	-45.74	158.57	-60.96	162.11	-47.27	171.30	-72.89	261.22	-59.20	270.41
150	-35.37	269.46	-59.43	149.38	-45.74	158.57	-60.96	162.11	-47.27	171.30	-72.89	261.22	-59.20	270.41
200	-35.37	269.46	-59.43	149.38	-45.74	158.57	-60.96	162.11	-47.27	171.30	-72.89	261.22	-59.20	270.41
300	-35.37	269.46	-59.43	149.38	-45.74	158.57	-60.96	162.11	-47.27	171.30	-72.89	261.22	-59.20	270.41
400	-35.37	269.46	-59.43	149.38	-45.74	158.57	-60.96	162.11	-47.27	171.30	-72.89	261.22	-59.20	270.41
500	-35.37	269.46	-59.43	149.38	-45.74	158.57	-60.96	162.11	-47.27	171.30	-72.89	261.22	-59.20	270.41
600	-35.37	269.46	-59.43	149.38	-45.74	158.57	-60.96	162.11	-47.27	171.30	-72.89	261.22	-59.20	270.41
700	-35.37	269.46	-59.43	149.38	-45.74	158.57	-60.96	162.11	-47.27	171.30	-72.89	261.22	-59.20	270.41
800	-35.37	269.46	-59.43	149.38	-45.74	158.57	-60.96	162.11	-47.27	171.30	-72.89	261.22	-59.20	270.41
900	-35.37	269.46	-59.43	149.38	-45.74	158.57	-60.96	162.11	-47.27	171.30	-72.89	261.22	-59.20	270.41
1000	-35.37	269.46	-59.43	149.38	-45.74	158.57	-60.96	162.11	-47.27	171.30	-72.89	261.22	-59.20	270.41
1200	-35.37	269.46	-59.43	149.38	-45.74	158.57	-60.96	162.11	-47.27	171.30	-72.89	261.22	-59.20	270.41
1500	-35.37	269.46	-59.43	149.38	-45.74	158.57	-60.96	162.11	-47.27	171.30	-72.89	261.22	-59.20	270.41
2000	-35.37	269.46	-59.43	149.38	-45.74	158.57	-60.96	162.11	-47.27	171.30	-72.89	261.22	-59.20	270.41
5000	-35.37	269.46	-59.43	149.38	-45.74	158.57	-60.96	162.11	-47.27	171.30	-72.89	261.22	-59.20	270.41
10000	-35.37	269.46	-59.43	149.38	-45.74	158.57	-60.96	162.11	-47.27	171.30	-72.89	261.22	-59.20	270.41
50000	-35.37	269.46	-59.43	149.38	-45.74	158.57	-60.96	162.11	-47.27	171.30	-72.89	261.22	-59.20	270.41
Tangent	-35.37	269.46	-59.43	149.38	-45.74	158.57	-60.96	162.11	-47.27	171.30	-72.89	261.22	-59.20	270.41

Met Council PROPOSED LOW FLOOR LIGHT RAIL VEHICLE

TABLE 11A - VEHICLE DYNAMIC ENVELOPE - OUTSIDE OF CURVE

Cross Level Variation = 1.0 in
Superelevation = 3.0 in

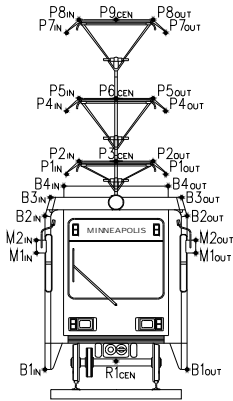

RADIUS FEET	R1 _{CEN}		B1 _{OUT}		M1 _{OUT}		M2 _{OUT}		B2 _{OUT}		B3 _{OUT}		B4 _{OUT}	
	X	Y	X	Y	X	Y	X	Y	X	Y	X	Y	X	Y
82	-1.08	16.99	75.80	7.76	83.99	96.57	84.34	116.63	79.39	134.10	66.25	147.74	61.39	154.78
100	-1.08	16.99	71.90	7.76	80.95	96.57	81.30	116.63	75.49	134.10	64.57	147.74	58.91	154.78
150	-1.08	16.99	65.69	7.76	76.06	96.57	76.41	116.63	69.28	134.10	61.85	147.74	54.98	154.78
200	-1.08	16.99	62.45	7.76	73.48	96.57	73.84	116.63	66.05	134.10	60.42	147.74	52.94	154.78
300	-1.08	16.99	59.14	7.76	70.83	96.57	71.18	116.63	62.73	134.10	58.93	147.74	50.85	154.78
400	-1.08	16.99	58.30	7.76	69.47	96.57	69.82	116.63	61.90	134.10	58.17	147.74	49.79	154.78
500	-1.08	16.99	57.84	7.76	68.64	96.57	68.99	116.63	61.44	134.10	57.71	147.74	49.15	154.78
600	-1.08	16.99	57.53	7.76	68.09	96.57	68.44	116.63	61.13	134.10	57.40	147.74	48.71	154.78
700	-1.08	16.99	57.31	7.76	67.69	96.57	68.04	116.63	60.91	134.10	57.18	147.74	48.41	154.78
800	-1.08	16.99	57.14	7.76	67.39	96.57	67.74	116.63	60.74	134.10	57.01	147.74	48.17	154.78
900	-1.08	16.99	57.01	7.76	67.15	96.57	67.51	116.63	60.61	134.10	56.88	147.74	47.99	154.78
1000	-1.08	16.99	56.91	7.76	66.97	96.57	67.32	116.63	60.50	134.10	56.77	147.74	47.85	154.78
1200	-1.08	16.99	56.75	7.76	66.68	96.57	67.04	116.63	60.35	134.10	56.62	147.74	47.63	154.78
1500	-1.08	16.99	56.59	7.76	66.40	96.57	66.75	116.63	60.19	134.10	56.46	147.74	47.41	154.78
2000	-1.08	16.99	56.43	7.76	66.12	96.57	66.47	116.63	60.03	134.10	56.30	147.74	47.19	154.78
5000	-1.08	16.99	56.15	7.76	65.61	96.57	65.96	116.63	59.74	134.10	56.01	147.74	46.79	154.78
10000	-1.08	16.99	56.05	7.76	65.43	96.57	65.79	116.63	59.65	134.10	55.92	147.74	46.66	154.78
50000	-1.08	16.99	55.97	7.76	65.30	96.57	65.65	116.63	59.57	134.10	55.84	147.74	46.56	154.78
Tangent	-1.08	16.99	55.95	7.76	65.26	96.57	65.62	116.63	59.55	134.10	55.82	147.74	46.53	154.78

NOTES:

Coordinates shown are in english units (mm)

Maximum values for each radius are shown in Bold Italicized font

All coordinates shown are referenced from a point located at 1/2 track gauge and top of rail (0,0)

Superelevation is applied relative to top of low rail

Points R1_{CEN}, P3_{CEN}, P6_{CEN} and P9_{CEN} are not specific to either Outside or Inside of curve

B# = LFLRV Body Points

M# = LFLRV Mirror Points

P# = LFLRV Pantograph Points

R# = LFLRV Roll Center Point

File Name: MIN-S.XLS
Revision By: SCA
Revision Date: 02/22/99

RADIUS FEET	P3 _{CEN}		P1 _{OUT}		P2 _{OUT}		P4 _{OUT}		P5 _{OUT}		P7 _{OUT}		P8 _{OUT}	
	X	Y	X	Y	X	Y	X	Y	X	Y	X	Y	X	Y
82	-24.55	157.96	47.36	152.07	32.73	159.92	47.82	164.70	33.19	172.55	51.40	263.01	36.77	271.12
100	-24.55	157.96	47.36	152.07	32.73	159.92	47.82	164.70	33.19	172.55	51.40	263.01	36.77	271.12
150	-24.55	157.96	47.36	152.07	32.73	159.92	47.82	164.70	33.19	172.55	51.40	263.01	36.77	271.12
200	-24.55	157.96	47.36	152.07	32.73	159.92	47.82	164.70	33.19	172.55	51.40	263.01	36.77	271.12
300	-24.55	157.96	47.36	152.07	32.73	159.92	47.82	164.70	33.19	172.55	51.40	263.01	36.77	271.12
400	-24.55	157.96	47.36	152.07	32.73	159.92	47.82	164.70	33.19	172.55	51.40	263.01	36.77	271.12
500	-24.55	157.96	47.36	152.07	32.73	159.92	47.82	164.70	33.19	172.55	51.40	263.01	36.77	271.12
600	-24.55	157.96	47.36	152.07	32.73	159.92	47.82	164.70	33.19	172.55	51.40	263.01	36.77	271.12
700	-24.55	157.96	47.36	152.07	32.73	159.92	47.82	164.70	33.19	172.55	51.40	263.01	36.77	271.12
800	-24.55	157.96	47.36	152.07	32.73	159.92	47.82	164.70	33.19	172.55	51.40	263.01	36.77	271.12
900	-24.55	157.96	47.36	152.07	32.73	159.92	47.82	164.70	33.19	172.55	51.40	263.01	36.77	271.12
1000	-24.55	157.96	47.36	152.07	32.73	159.92	47.82	164.70	33.19	172.55	51.40	263.01	36.77	271.12
1200	-24.55	157.96	47.36	152.07	32.73	159.92	47.82	164.70	33.19	172.55	51.40	263.01	36.77	271.12
1500	-24.55	157.96	47.36	152.07	32.73	159.92	47.82	164.70	33.19	172.55	51.40	263.01	36.77	271.12
2000	-24.55	157.96	47.36	152.07	32.73	159.92	47.82	164.70	33.19	172.55	51.40	263.01	36.77	271.12
5000	-24.55	157.96	47.36	152.07	32.73	159.92	47.82	164.70	33.19	172.55	51.40	263.01	36.77	271.12
10000	-24.55	157.96	47.36	152.07	32.73	159.92	47.82	164.70	33.19	172.55	51.40	263.01	36.77	271.12
50000	-24.55	157.96	47.36	152.07	32.73	159.92	47.82	164.70	33.19	172.55	51.40	263.01	36.77	271.12
Tangent	-24.55	157.96	47.36	152.07	32.73	159.92	47.82	164.70	33.19	172.55	51.40	263.01	36.77	271.12

Met Council PROPOSED LOW FLOOR LIGHT RAIL VEHICLE

TABLE 11B - VEHICLE DYNAMIC ENVELOPE - INSIDE OF CURVE

Cross Level Variation = 1.0 in
Superelevation = 3.0 in

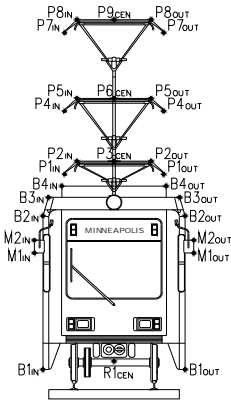

NOTES:

Coordinates shown are in english units (mm)

Maximum values for each radius are shown in Bold Italicized font

All coordinates shown are referenced from a point located at 1/2 track gauge and top of rail (0,0)

Superelevation is applied relative to top of low rail

Points R1_{CEN}, P3_{CEN}, P6_{CEN} and P9_{CEN} are not specific to either Outside or Inside of curve

B# = LFLRV Body Points

M# = LFLRV Mirror Points

P# = LFLRV Pantograph Points

R# = LFLRV Roll Center Point

File Name: MIN-S.XLS
Revision By: SCA
Revision Date: 02/22/99

RADIUS FEET	P6 _{CEN}		B1 _{IN}		M1 _{IN}		M2 _{IN}		B2 _{IN}		B3 _{IN}		B4 _{IN}	
	X	Y	X	Y	X	Y	X	Y	X	Y	X	Y	X	Y
82	-26.30	170.71	-71.82	2.50	-82.58	89.90	-83.91	111.55	-86.51	129.81	-84.26	144.00	-75.64	152.11
100	-26.30	170.71	-68.99	2.50	-79.75	89.90	-81.08	111.55	-83.67	129.81	-81.43	144.00	-72.80	152.11
150	-26.30	170.71	-64.72	2.50	-75.48	89.90	-76.82	111.55	-79.41	129.81	-77.16	144.00	-68.54	152.11
200	-26.30	170.71	-62.60	2.50	-73.36	89.90	-74.70	111.55	-77.29	129.81	-75.04	144.00	-66.42	152.11
300	-26.30	170.71	-60.49	2.50	-71.25	89.90	-72.58	111.55	-75.17	129.81	-72.92	144.00	-64.30	152.11
400	-26.30	170.71	-59.43	2.50	-70.30	89.90	-71.63	111.55	-74.11	129.81	-71.87	144.00	-63.25	152.11
500	-26.30	170.71	-58.80	2.50	-71.19	89.90	-72.52	111.55	-73.48	129.81	-71.24	144.00	-62.61	152.11
600	-26.30	170.71	-58.37	2.50	-71.78	89.90	-73.12	111.55	-73.06	129.81	-70.81	144.00	-62.19	152.11
700	-26.30	170.71	-58.07	2.50	-72.20	89.90	-73.53	111.55	-72.76	129.81	-70.51	144.00	-61.89	152.11
800	-26.30	170.71	-57.85	2.50	-72.51	89.90	-73.85	111.55	-72.53	129.81	-70.29	144.00	-61.66	152.11
900	-26.30	170.71	-57.67	2.50	-72.76	89.90	-74.09	111.55	-72.36	129.81	-70.11	144.00	-61.49	152.11
1000	-26.30	170.71	-57.53	2.50	-72.95	89.90	-74.29	111.55	-72.22	129.81	-69.97	144.00	-61.35	152.11
1200	-26.30	170.71	-57.32	2.50	-73.24	89.90	-74.58	111.55	-72.00	129.81	-69.76	144.00	-61.14	152.11
1500	-26.30	170.71	-57.11	2.50	-73.53	89.90	-74.87	111.55	-71.79	129.81	-69.55	144.00	-60.93	152.11
2000	-26.30	170.71	-56.90	2.50	-73.82	89.90	-75.16	111.55	-71.58	129.81	-69.34	144.00	-60.71	152.11
5000	-26.30	170.71	-56.99	2.50	-74.34	89.90	-75.67	111.55	-71.68	129.81	-69.43	144.00	-61.01	152.11
10000	-26.30	170.71	-57.09	2.50	-74.51	89.90	-75.85	111.55	-71.78	129.81	-69.53	144.00	-61.14	152.11
50000	-26.30	170.71	-57.17	2.50	-74.65	89.90	-75.98	111.55	-71.85	129.81	-69.61	144.00	-61.25	152.11
Tangent	-26.30	170.71	-57.19	2.50	-74.68	89.90	-76.02	111.55	-71.87	129.81	-69.63	144.00	-61.28	152.11

RADIUS FEET	P9 _{CEN}		P1 _{IN}		P2 _{IN}		P4 _{IN}		P5 _{IN}		P7 _{IN}		P8 _{IN}	
	X	Y	X	Y	X	Y	X	Y	X	Y	X	Y	X	Y
82	-39.88	269.96	-61.81	149.31	-48.32	158.76	-63.56	162.05	-50.07	171.51	-77.15	261.24	-63.66	270.69
100	-39.88	269.96	-61.81	149.31	-48.32	158.76	-63.56	162.05	-50.07	171.51	-77.15	261.24	-63.66	270.69
150	-39.88	269.96	-61.81	149.31	-48.32	158.76	-63.56	162.05	-50.07	171.51	-77.15	261.24	-63.66	270.69
200	-39.88	269.96	-61.81	149.31	-48.32	158.76	-63.56	162.05	-50.07	171.51	-77.15	261.24	-63.66	270.69
300	-39.88	269.96	-61.81	149.31	-48.32	158.76	-63.56	162.05	-50.07	171.51	-77.15	261.24	-63.66	270.69
400	-39.88	269.96	-61.81	149.31	-48.32	158.76	-63.56	162.05	-50.07	171.51	-77.15	261.24	-63.66	270.69
500	-39.88	269.96	-61.81	149.31	-48.32	158.76	-63.56	162.05	-50.07	171.51	-77.15	261.24	-63.66	270.69
600	-39.88	269.96	-61.81	149.31	-48.32	158.76	-63.56	162.05	-50.07	171.51	-77.15	261.24	-63.66	270.69
700	-39.88	269.96	-61.81	149.31	-48.32	158.76	-63.56	162.05	-50.07	171.51	-77.15	261.24	-63.66	270.69
800	-39.88	269.96	-61.81	149.31	-48.32	158.76	-63.56	162.05	-50.07	171.51	-77.15	261.24	-63.66	270.69
900	-39.88	269.96	-61.81	149.31	-48.32	158.76	-63.56	162.05	-50.07	171.51	-77.15	261.24	-63.66	270.69
1000	-39.88	269.96	-61.81	149.31	-48.32	158.76	-63.56	162.05	-50.07	171.51	-77.15	261.24	-63.66	270.69
1200	-39.88	269.96	-61.81	149.31	-48.32	158.76	-63.56	162.05	-50.07	171.51	-77.15	261.24	-63.66	270.69
1500	-39.88	269.96	-61.81	149.31	-48.32	158.76	-63.56	162.05	-50.07	171.51	-77.15	261.24	-63.66	270.69
2000	-39.88	269.96	-61.81	149.31	-48.32	158.76	-63.56	162.05	-50.07	171.51	-77.15	261.24	-63.66	270.69
5000	-39.88	269.96	-61.81	149.31	-48.32	158.76	-63.56	162.05	-50.07	171.51	-77.15	261.24	-63.66	270.69
10000	-39.88	269.96	-61.81	149.31	-48.32	158.76	-63.56	162.05	-50.07	171.51	-77.15	261.24	-63.66	270.69
50000	-39.88	269.96	-61.81	149.31	-48.32	158.76	-63.56	162.05	-50.07	171.51	-77.15	261.24	-63.66	270.69
Tangent	-39.88	269.96	-61.81	149.31	-48.32	158.76	-63.56	162.05	-50.07	171.51	-77.15	261.24	-63.66	270.69

Met Council PROPOSED LOW FLOOR LIGHT RAIL VEHICLE

TABLE 12A - VEHICLE DYNAMIC ENVELOPE - OUTSIDE OF CURVE

Cross Level Variation = 1.0 in
Superelevation = 4.0 in

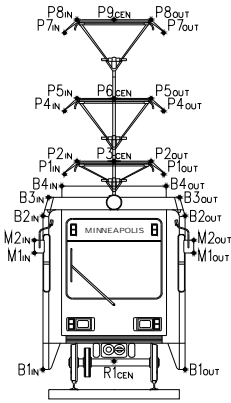

NOTES:

Coordinates shown are in english units (mm)

Maximum values for each radius are shown in Bold Italicized font

All coordinates shown are referenced from a point located at 1/2 track gauge and top of rail (0,0)

Superelevation is applied relative to top of low rail

Points R1_{CEN}, P3_{CEN}, P6_{CEN} and P9_{CEN} are not specific to either Outside or Inside of curve

B# = LFLRV Body Points

M# = LFLRV Mirror Points

P# = LFLRV Pantograph Points

R# = LFLRV Roll Center Point

File Name: MIN-S.XLS

Revision By: SCA

Revision Date: 02/22/99

RADIUS FEET	R1 _{CEN}		B1 _{OUT}		M1 _{OUT}		M2 _{OUT}		B2 _{OUT}		B3 _{OUT}		B4 _{OUT}	
	X	Y	X	Y	X	Y	X	Y	X	Y	X	Y	X	Y
82	-1.37	17.48	75.53	9.13	82.35	98.08	82.54	117.85	77.28	135.18	63.89	148.71	58.88	155.57
100	-1.37	17.48	71.63	9.13	79.31	98.08	79.50	117.85	73.38	135.18	62.21	148.71	56.41	155.57
150	-1.37	17.48	65.42	9.13	74.42	98.08	74.61	117.85	67.17	135.18	59.49	148.71	52.48	155.57
200	-1.37	17.48	62.19	9.13	71.85	98.08	72.03	117.85	63.94	135.18	58.06	148.71	50.44	155.57
300	-1.37	17.48	58.87	9.13	69.19	98.08	69.38	117.85	60.62	135.18	56.58	148.71	48.35	155.57
400	-1.37	17.48	58.04	9.13	67.83	98.08	68.02	117.85	59.78	135.18	55.82	148.71	47.28	155.57
500	-1.37	17.48	57.58	9.13	67.00	98.08	67.19	117.85	59.32	135.18	55.35	148.71	46.64	155.57
600	-1.37	17.48	57.27	9.13	66.45	98.08	66.64	117.85	59.01	135.18	55.04	148.71	46.21	155.57
700	-1.37	17.48	57.04	9.13	66.05	98.08	66.24	117.85	58.79	135.18	54.82	148.71	45.90	155.57
800	-1.37	17.48	56.88	9.13	65.75	98.08	65.94	117.85	58.62	135.18	54.65	148.71	45.67	155.57
900	-1.37	17.48	56.75	9.13	65.52	98.08	65.70	117.85	58.49	135.18	54.52	148.71	45.49	155.57
1000	-1.37	17.48	56.64	9.13	65.33	98.08	65.52	117.85	58.39	135.18	54.42	148.71	45.34	155.57
1200	-1.37	17.48	56.48	9.13	65.05	98.08	65.23	117.85	58.23	135.18	54.26	148.71	45.12	155.57
1500	-1.37	17.48	56.33	9.13	64.76	98.08	64.95	117.85	58.07	135.18	54.10	148.71	44.90	155.57
2000	-1.37	17.48	56.17	9.13	64.48	98.08	64.67	117.85	57.91	135.18	53.94	148.71	44.68	155.57
5000	-1.37	17.48	55.88	9.13	63.97	98.08	64.16	117.85	57.63	135.18	53.65	148.71	44.29	155.57
10000	-1.37	17.48	55.78	9.13	63.80	98.08	63.98	117.85	57.53	135.18	53.56	148.71	44.16	155.57
50000	-1.37	17.48	55.71	9.13	63.66	98.08	63.85	117.85	57.45	135.18	53.48	148.71	44.05	155.57
Tangent	-1.37	17.48	55.69	9.13	63.63	98.08	63.81	117.85	57.43	135.18	53.46	148.71	44.02	155.57

RADIUS FEET	P3 _{CEN}		P1 _{OUT}		P2 _{OUT}		P4 _{OUT}		P5 _{OUT}		P7 _{OUT}		P8 _{OUT}	
	X	Y	X	Y	X	Y	X	Y	X	Y	X	Y	X	Y
82	-27.19	158.45	44.90	152.88	30.09	160.45	45.14	165.47	30.34	173.05	47.06	263.55	32.25	271.56
100	-27.19	158.45	44.90	152.88	30.09	160.45	45.14	165.47	30.34	173.05	47.06	263.55	32.25	271.56
150	-27.19	158.45	44.90	152.88	30.09	160.45	45.14	165.47	30.34	173.05	47.06	263.55	32.25	271.56
200	-27.19	158.45	44.90	152.88	30.09	160.45	45.14	165.47	30.34	173.05	47.06	263.55	32.25	271.56
300	-27.19	158.45	44.90	152.88	30.09	160.45	45.14	165.47	30.34	173.05	47.06	263.55	32.25	271.56
400	-27.19	158.45	44.90	152.88	30.09	160.45	45.14	165.47	30.34	173.05	47.06	263.55	32.25	271.56
500	-27.19	158.45	44.90	152.88	30.09	160.45	45.14	165.47	30.34	173.05	47.06	263.55	32.25	271.56
600	-27.19	158.45	44.90	152.88	30.09	160.45	45.14	165.47	30.34	173.05	47.06	263.55	32.25	271.56
700	-27.19	158.45	44.90	152.88	30.09	160.45	45.14	165.47	30.34	173.05	47.06	263.55	32.25	271.56
800	-27.19	158.45	44.90	152.88	30.09	160.45	45.14	165.47	30.34	173.05	47.06	263.55	32.25	271.56
900	-27.19	158.45	44.90	152.88	30.09	160.45	45.14	165.47	30.34	173.05	47.06	263.55	32.25	271.56
1000	-27.19	158.45	44.90	152.88	30.09	160.45	45.14	165.47	30.34	173.05	47.06	263.55	32.25	271.56
1200	-27.19	158.45	44.90	152.88	30.09	160.45	45.14	165.47	30.34	173.05	47.06	263.55	32.25	271.56
1500	-27.19	158.45	44.90	152.88	30.09	160.45	45.14	165.47	30.34	173.05	47.06	263.55	32.25	271.56
2000	-27.19	158.45	44.90	152.88	30.09	160.45	45.14	165.47	30.34	173.05	47.06	263.55	32.25	271.56
5000	-27.19	158.45	44.90	152.88	30.09	160.45	45.14	165.47	30.34	173.05	47.06	263.55	32.25	271.56
10000	-27.19	158.45	44.90	152.88	30.09	160.45	45.14	165.47	30.34	173.05	47.06	263.55	32.25	271.56
50000	-27.19	158.45	44.90	152.88	30.09	160.45	45.14	165.47	30.34	173.05	47.06	263.55	32.25	271.56
Tangent	-27.19	158.45	44.90	152.88	30.09	160.45	45.14	165.47	30.34	173.05	47.06	263.55	32.25	271.56

Met Council PROPOSED LOW FLOOR LIGHT RAIL VEHICLE

TABLE 12B - VEHICLE DYNAMIC ENVELOPE - INSIDE OF CURVE

Cross Level Variation = 1.0 in
Superelevation = 4.0 in

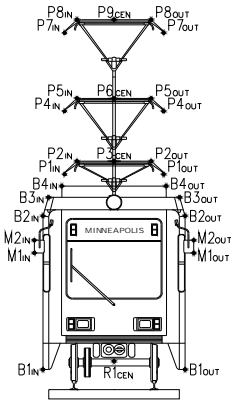

RADIUS FEET	P6 _{CEN}		B1 _{IN}		M1 _{IN}		M2 _{IN}		B2 _{IN}		B3 _{IN}		B4 _{IN}	
	X	Y	X	Y	X	Y	X	Y	X	Y	X	Y	X	Y
82	-29.14	171.20	-72.00	2.12	-84.10	89.20	-85.60	111.09	-88.51	129.47	-86.52	143.73	-78.06	152.01
100	-29.14	171.20	-69.16	2.12	-81.27	89.20	-82.77	111.09	-85.68	129.47	-83.68	143.73	-75.23	152.01
150	-29.14	171.20	-64.90	2.12	-77.00	89.20	-78.50	111.09	-81.42	129.47	-79.42	143.73	-70.96	152.01
200	-29.14	171.20	-62.78	2.12	-74.88	89.20	-76.38	111.09	-79.29	129.47	-77.30	143.73	-68.84	152.01
300	-29.14	171.20	-60.66	2.12	-72.77	89.20	-74.27	111.09	-77.18	129.47	-75.18	143.73	-66.73	152.01
400	-29.14	171.20	-59.61	2.12	-71.82	89.20	-73.32	111.09	-74.12	129.47	-74.13	143.73	-65.67	152.01
500	-29.14	171.20	-58.97	2.12	-72.71	89.20	-74.21	111.09	-75.49	129.47	-73.49	143.73	-65.04	152.01
600	-29.14	171.20	-58.55	2.12	-73.30	89.20	-74.80	111.09	-75.07	129.47	-73.07	143.73	-64.61	152.01
700	-29.14	171.20	-58.25	2.12	-73.72	89.20	-75.22	111.09	-74.77	129.47	-72.77	143.73	-64.31	152.01
800	-29.14	171.20	-58.02	2.12	-74.04	89.20	-75.53	111.09	-74.54	129.47	-72.54	143.73	-64.09	152.01
900	-29.14	171.20	-57.85	2.12	-74.28	89.20	-75.78	111.09	-74.37	129.47	-72.37	143.73	-63.91	152.01
1000	-29.14	171.20	-57.71	2.12	-74.48	89.20	-75.97	111.09	-74.22	129.47	-72.23	143.73	-63.77	152.01
1200	-29.14	171.20	-57.50	2.12	-74.77	89.20	-76.26	111.09	-74.01	129.47	-72.02	143.73	-63.56	152.01
1500	-29.14	171.20	-57.29	2.12	-75.06	89.20	-76.55	111.09	-73.80	129.47	-71.81	143.73	-63.35	152.01
2000	-29.14	171.20	-57.07	2.12	-75.35	89.20	-76.84	111.09	-73.59	129.47	-71.60	143.73	-63.14	152.01
5000	-29.14	171.20	-57.17	2.12	-75.86	89.20	-77.36	111.09	-73.69	129.47	-71.69	143.73	-63.43	152.01
10000	-29.14	171.20	-57.27	2.12	-76.04	89.20	-77.53	111.09	-73.78	129.47	-71.79	143.73	-63.57	152.01
50000	-29.14	171.20	-57.34	2.12	-76.17	89.20	-77.67	111.09	-73.86	129.47	-71.87	143.73	-63.67	152.01
Tangent	-29.14	171.20	-57.36	2.12	-76.21	89.20	-77.70	111.09	-73.88	129.47	-71.88	143.73	-63.70	152.01

NOTES:

Coordinates shown are in english units (mm)

Maximum values for each radius are shown in Bold Italicized font

All coordinates shown are referenced from a point located at 1/2 track gauge and top of rail (0,0)

Superelevation is applied relative to top of low rail

Points R1_{CEN}, P3_{CEN}, P6_{CEN} and P9_{CEN} are not specific to either Outside or Inside of curve

B# = LFLRV Body Points

M# = LFLRV Mirror Points

P# = LFLRV Pantograph Points

R# = LFLRV Roll Center Point

File Name: MIN-S.XLS
Revision By: SCA
Revision Date: 02/22/99

RADIUS FEET	P9 _{CEN}		P1 _{IN}		P2 _{IN}		P4 _{IN}		P5 _{IN}		P7 _{IN}		P8 _{IN}	
	X	Y	X	Y	X	Y	X	Y	X	Y	X	Y	X	Y
82	-44.38	270.43	-64.19	149.20	-50.90	158.91	-66.15	161.95	-52.86	171.66	-81.39	261.18	-68.10	270.89
100	-44.38	270.43	-64.19	149.20	-50.90	158.91	-66.15	161.95	-52.86	171.66	-81.39	261.18	-68.10	270.89
150	-44.38	270.43	-64.19	149.20	-50.90	158.91	-66.15	161.95	-52.86	171.66	-81.39	261.18	-68.10	270.89
200	-44.38	270.43	-64.19	149.20	-50.90	158.91	-66.15	161.95	-52.86	171.66	-81.39	261.18	-68.10	270.89
300	-44.38	270.43	-64.19	149.20	-50.90	158.91	-66.15	161.95	-52.86	171.66	-81.39	261.18	-68.10	270.89
400	-44.38	270.43	-64.19	149.20	-50.90	158.91	-66.15	161.95	-52.86	171.66	-81.39	261.18	-68.10	270.89
500	-44.38	270.43	-64.19	149.20	-50.90	158.91	-66.15	161.95	-52.86	171.66	-81.39	261.18	-68.10	270.89
600	-44.38	270.43	-64.19	149.20	-50.90	158.91	-66.15	161.95	-52.86	171.66	-81.39	261.18	-68.10	270.89
700	-44.38	270.43	-64.19	149.20	-50.90	158.91	-66.15	161.95	-52.86	171.66	-81.39	261.18	-68.10	270.89
800	-44.38	270.43	-64.19	149.20	-50.90	158.91	-66.15	161.95	-52.86	171.66	-81.39	261.18	-68.10	270.89
900	-44.38	270.43	-64.19	149.20	-50.90	158.91	-66.15	161.95	-52.86	171.66	-81.39	261.18	-68.10	270.89
1000	-44.38	270.43	-64.19	149.20	-50.90	158.91	-66.15	161.95	-52.86	171.66	-81.39	261.18	-68.10	270.89
1200	-44.38	270.43	-64.19	149.20	-50.90	158.91	-66.15	161.95	-52.86	171.66	-81.39	261.18	-68.10	270.89
1500	-44.38	270.43	-64.19	149.20	-50.90	158.91	-66.15	161.95	-52.86	171.66	-81.39	261.18	-68.10	270.89
2000	-44.38	270.43	-64.19	149.20	-50.90	158.91	-66.15	161.95	-52.86	171.66	-81.39	261.18	-68.10	270.89
5000	-44.38	270.43	-64.19	149.20	-50.90	158.91	-66.15	161.95	-52.86	171.66	-81.39	261.18	-68.10	270.89
10000	-44.38	270.43	-64.19	149.20	-50.90	158.91	-66.15	161.95	-52.86	171.66	-81.39	261.18	-68.10	270.89
50000	-44.38	270.43	-64.19	149.20	-50.90	158.91	-66.15	161.95	-52.86	171.66	-81.39	261.18	-68.10	270.89
Tangent	-44.38	270.43	-64.19	149.20	-50.90	158.91	-66.15	161.95	-52.86	171.66	-81.39	261.18	-68.10	270.89

Met Council PROPOSED LOW FLOOR LIGHT RAIL VEHICLE

TABLE 13A - VEHICLE DYNAMIC ENVELOPE - OUTSIDE OF CURVE

Cross Level Variation = 1.0 in
Superelevation = 5.0 in

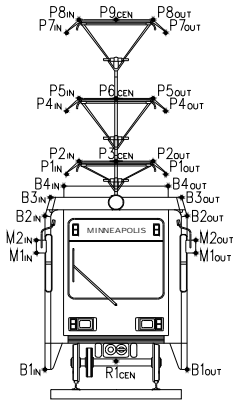

NOTES:

Coordinates shown are in english units (mm)

Maximum values for each radius are shown in Bold Italicized font

All coordinates shown are referenced from a point located at 1/2 track gauge and top of rail (0,0)

Superelevation is applied relative to top of low rail

Points R1_{CEN}, P3_{CEN}, P6_{CEN} and P9_{CEN} are not specific to either Outside or Inside of curve

B# = LFLRV Body Points

M# = LFLRV Mirror Points

P# = LFLRV Pantograph Points

R# = LFLRV Roll Center Point

File Name: MIN-S.XLS
Revision By: SCA
Revision Date: 02/22/99

RADIUS FEET	R1 _{CEN}		B1 _{OUT}		M1 _{OUT}		M2 _{OUT}		B2 _{OUT}		B3 _{OUT}		B4 _{OUT}	
	X	Y	X	Y	X	Y	X	Y	X	Y	X	Y	X	Y
82	-1.67	17.96	75.24	10.49	80.70	99.56	80.72	119.05	75.14	136.22	61.52	149.64	56.36	156.31
100	-1.67	17.96	71.34	10.49	77.66	99.56	77.68	119.05	71.24	136.22	59.83	149.64	53.89	156.31
150	-1.67	17.96	65.13	10.49	72.76	99.56	72.78	119.05	65.03	136.22	57.12	149.64	49.96	156.31
200	-1.67	17.96	61.90	10.49	70.19	99.56	70.21	119.05	61.80	136.22	55.68	149.64	47.92	156.31
300	-1.67	17.96	58.58	10.49	67.53	99.56	67.55	119.05	58.48	136.22	54.20	149.64	45.83	156.31
400	-1.67	17.96	57.75	10.49	66.17	99.56	66.19	119.05	57.65	136.22	53.44	149.64	44.76	156.31
500	-1.67	17.96	57.29	10.49	65.34	99.56	65.37	119.05	57.19	136.22	52.98	149.64	44.12	156.31
600	-1.67	17.96	56.98	10.49	64.79	99.56	64.81	119.05	56.88	136.22	52.67	149.64	43.69	156.31
700	-1.67	17.96	56.76	10.49	64.39	99.56	64.41	119.05	56.66	136.22	52.44	149.64	43.38	156.31
800	-1.67	17.96	56.59	10.49	64.09	99.56	64.12	119.05	56.49	136.22	52.28	149.64	43.15	156.31
900	-1.67	17.96	56.46	10.49	63.86	99.56	63.88	119.05	56.36	136.22	52.14	149.64	42.96	156.31
1000	-1.67	17.96	56.35	10.49	63.67	99.56	63.69	119.05	56.25	136.22	52.04	149.64	42.82	156.31
1200	-1.67	17.96	56.20	10.49	63.39	99.56	63.41	119.05	56.10	136.22	51.88	149.64	42.60	156.31
1500	-1.67	17.96	56.04	10.49	63.11	99.56	63.13	119.05	55.94	136.22	51.72	149.64	42.38	156.31
2000	-1.67	17.96	55.88	10.49	62.82	99.56	62.85	119.05	55.78	136.22	51.56	149.64	42.16	156.31
5000	-1.67	17.96	55.59	10.49	62.31	99.56	62.33	119.05	55.49	136.22	51.28	149.64	41.77	156.31
10000	-1.67	17.96	55.49	10.49	62.14	99.56	62.16	119.05	55.39	136.22	51.18	149.64	41.64	156.31
50000	-1.67	17.96	55.42	10.49	62.00	99.56	62.02	119.05	55.32	136.22	51.10	149.64	41.53	156.31
Tangent	-1.67	17.96	55.40	10.49	61.97	99.56	61.99	119.05	55.30	136.22	51.08	149.64	41.50	156.31

RADIUS FEET	P3 _{CEN}		P1 _{OUT}		P2 _{OUT}		P4 _{OUT}		P5 _{OUT}		P7 _{OUT}		P8 _{OUT}	
	X	Y	X	Y	X	Y	X	Y	X	Y	X	Y	X	Y
82	-29.82	158.96	42.43	153.64	27.45	160.94	42.46	166.20	27.48	173.55	42.70	264.01	27.73	272.04
100	-29.82	158.96	42.43	153.64	27.45	160.94	42.46	166.20	27.48	173.55	42.70	264.01	27.73	272.04
150	-29.82	158.96	42.43	153.64	27.45	160.94	42.46	166.20	27.48	173.55	42.70	264.01	27.73	272.04
200	-29.82	158.96	42.43	153.64	27.45	160.94	42.46	166.20	27.48	173.55	42.70	264.01	27.73	272.04
300	-29.82	158.96	42.43	153.64	27.45	160.94	42.46	166.20	27.48	173.55	42.70	264.01	27.73	272.04
400	-29.82	158.96	42.43	153.64	27.45	160.94	42.46	166.20	27.48	173.55	42.70	264.01	27.73	272.04
500	-29.82	158.96	42.43	153.64	27.45	160.94	42.46	166.20	27.48	173.55	42.70	264.01	27.73	272.04
600	-29.82	158.96	42.43	153.64	27.45	160.94	42.46	166.20	27.48	173.55	42.70	264.01	27.73	272.04
700	-29.82	158.96	42.43	153.64	27.45	160.94	42.46	166.20	27.48	173.55	42.70	264.01	27.73	272.04
800	-29.82	158.96	42.43	153.64	27.45	160.94	42.46	166.20	27.48	173.55	42.70	264.01	27.73	272.04
900	-29.82	158.96	42.43	153.64	27.45	160.94	42.46	166.20	27.48	173.55	42.70	264.01	27.73	272.04
1000	-29.82	158.96	42.43	153.64	27.45	160.94	42.46	166.20	27.48	173.55	42.70	264.01	27.73	272.04
1200	-29.82	158.96	42.43	153.64	27.45	160.94	42.46	166.20	27.48	173.55	42.70	264.01	27.73	272.04
1500	-29.82	158.96	42.43	153.64	27.45	160.94	42.46	166.20	27.48	173.55	42.70	264.01	27.73	272.04
2000	-29.82	158.96	42.43	153.64	27.45	160.94	42.46	166.20	27.48	173.55	42.70	264.01	27.73	272.04
5000	-29.82	158.96	42.43	153.64	27.45	160.94	42.46	166.20	27.48	173.55	42.70	264.01	27.73	272.04
10000	-29.82	158.96	42.43	153.64	27.45	160.94	42.46	166.20	27.48	173.55	42.70	264.01	27.73	272.04
50000	-29.82	158.96	42.43	153.64	27.45	160.94	42.46	166.20	27.48	173.55	42.70	264.01	27.73	272.04
Tangent	-29.82	158.96	42.43	153.64	27.45	160.94	42.46	166.20	27.48	173.55	42.70	264.01	27.73	272.04

Met Council PROPOSED LOW FLOOR LIGHT RAIL VEHICLE

TABLE 13B - VEHICLE DYNAMIC ENVELOPE - INSIDE OF CURVE

Cross Level Variation = 1.0 in
Superelevation = 5.0 in

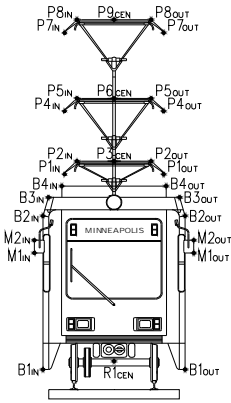

NOTES:

Coordinates shown are in english units (mm)

Maximum values for each radius are shown in Bold Italicized font

All coordinates shown are referenced from a point located at 1/2 track gauge and top of rail (0,0)

Superelevation is applied relative to top of low rail

Points R1_{CEN}, P3_{CEN}, P6_{CEN} and P9_{CEN} are not specific to either Outside or Inside of curve

B# = LFLRV Body Points
M# = LFLRV Mirror Points
P# = LFLRV Pantograph Points
R# = LFLRV Roll Center Point

File Name: MIN-S.XLS
Revision By: SCA
Revision Date: 02/22/99

RADIUS FEET	P6 _{CEN}		B1 _{IN}		M1 _{IN}		M2 _{IN}		B2 _{IN}		B3 _{IN}		B4 _{IN}	
	X	Y	X	Y	X	Y	X	Y	X	Y	X	Y	X	Y
82	-31.99	171.71	-72.17	1.73	-85.61	88.47	-87.27	110.60	-90.51	129.09	-88.76	143.43	-80.47	151.87
100	-31.99	171.71	-69.33	1.73	-82.78	88.47	-84.44	110.60	-87.67	129.09	-85.93	143.43	-77.64	151.87
150	-31.99	171.71	-65.07	1.73	-78.51	88.47	-80.17	110.60	-83.41	129.09	-81.66	143.43	-73.37	151.87
200	-31.99	171.71	-62.95	1.73	-76.39	88.47	-78.05	110.60	-81.29	129.09	-79.54	143.43	-71.25	151.87
300	-31.99	171.71	-60.83	1.73	-74.28	88.47	-75.94	110.60	-79.17	129.09	-77.43	143.43	-69.14	151.87
400	-31.99	171.71	-59.78	1.73	-73.33	88.47	-74.99	110.60	-78.12	129.09	-76.37	143.43	-68.08	151.87
500	-31.99	171.71	-59.14	1.73	-74.22	88.47	-75.88	110.60	-77.48	129.09	-75.74	143.43	-67.45	151.87
600	-31.99	171.71	-58.72	1.73	-74.81	88.47	-76.47	110.60	-77.06	129.09	-75.31	143.43	-67.02	151.87
700	-31.99	171.71	-58.42	1.73	-75.23	88.47	-76.89	110.60	-76.76	129.09	-75.01	143.43	-66.72	151.87
800	-31.99	171.71	-58.19	1.73	-75.55	88.47	-77.20	110.60	-76.53	129.09	-74.79	143.43	-66.50	151.87
900	-31.99	171.71	-58.02	1.73	-75.79	88.47	-77.45	110.60	-76.36	129.09	-74.61	143.43	-66.32	151.87
1000	-31.99	171.71	-57.88	1.73	-75.98	88.47	-77.64	110.60	-76.22	129.09	-74.47	143.43	-66.18	151.87
1200	-31.99	171.71	-57.67	1.73	-76.27	88.47	-77.93	110.60	-76.01	129.09	-74.26	143.43	-65.97	151.87
1500	-31.99	171.71	-57.46	1.73	-76.56	88.47	-78.22	110.60	-75.80	129.09	-74.05	143.43	-65.76	151.87
2000	-31.99	171.71	-57.25	1.73	-76.85	88.47	-78.51	110.60	-75.58	129.09	-73.84	143.43	-65.55	151.87
5000	-31.99	171.71	-57.34	1.73	-77.37	88.47	-79.03	110.60	-75.68	129.09	-73.93	143.43	-65.84	151.87
10000	-31.99	171.71	-57.44	1.73	-77.54	88.47	-79.20	110.60	-75.78	129.09	-74.03	143.43	-65.98	151.87
50000	-31.99	171.71	-57.51	1.73	-77.68	88.47	-79.34	110.60	-75.85	129.09	-74.11	143.43	-66.08	151.87
Tangent	-31.99	171.71	-57.53	1.73	-77.72	88.47	-79.37	110.60	-75.87	129.09	-74.13	143.43	-66.11	151.87

RADIUS FEET	P9 _{CEN}		P1 _{IN}		P2 _{IN}		P4 _{IN}		P5 _{IN}		P7 _{IN}		P8 _{IN}	
	X	Y	X	Y	X	Y	X	Y	X	Y	X	Y	X	Y
82	-48.87	270.96	-66.55	149.05	-53.47	159.02	-68.72	161.80	-55.64	171.77	-85.60	261.05	-72.52	271.02
100	-48.87	270.96	-66.55	149.05	-53.47	159.02	-68.72	161.80	-55.64	171.77	-85.60	261.05	-72.52	271.02
150	-48.87	270.96	-66.55	149.05	-53.47	159.02	-68.72	161.80	-55.64	171.77	-85.60	261.05	-72.52	271.02
200	-48.87	270.96	-66.55	149.05	-53.47	159.02	-68.72	161.80	-55.64	171.77	-85.60	261.05	-72.52	271.02
300	-48.87	270.96	-66.55	149.05	-53.47	159.02	-68.72	161.80	-55.64	171.77	-85.60	261.05	-72.52	271.02
400	-48.87	270.96	-66.55	149.05	-53.47	159.02	-68.72	161.80	-55.64	171.77	-85.60	261.05	-72.52	271.02
500	-48.87	270.96	-66.55	149.05	-53.47	159.02	-68.72	161.80	-55.64	171.77	-85.60	261.05	-72.52	271.02
600	-48.87	270.96	-66.55	149.05	-53.47	159.02	-68.72	161.80	-55.64	171.77	-85.60	261.05	-72.52	271.02
700	-48.87	270.96	-66.55	149.05	-53.47	159.02	-68.72	161.80	-55.64	171.77	-85.60	261.05	-72.52	271.02
800	-48.87	270.96	-66.55	149.05	-53.47	159.02	-68.72	161.80	-55.64	171.77	-85.60	261.05	-72.52	271.02
900	-48.87	270.96	-66.55	149.05	-53.47	159.02	-68.72	161.80	-55.64	171.77	-85.60	261.05	-72.52	271.02
1000	-48.87	270.96	-66.55	149.05	-53.47	159.02	-68.72	161.80	-55.64	171.77	-85.60	261.05	-72.52	271.02
1200	-48.87	270.96	-66.55	149.05	-53.47	159.02	-68.72	161.80	-55.64	171.77	-85.60	261.05	-72.52	271.02
1500	-48.87	270.96	-66.55	149.05	-53.47	159.02	-68.72	161.80	-55.64	171.77	-85.60	261.05	-72.52	271.02
2000	-48.87	270.96	-66.55	149.05	-53.47	159.02	-68.72	161.80	-55.64	171.77	-85.60	261.05	-72.52	271.02
5000	-48.87	270.96	-66.55	149.05	-53.47	159.02	-68.72	161.80	-55.64	171.77	-85.60	261.05	-72.52	271.02
10000	-48.87	270.96	-66.55	149.05	-53.47	159.02	-68.72	161.80	-55.64	171.77	-85.60	261.05	-72.52	271.02
50000	-48.87	270.96	-66.55	149.05	-53.47	159.02	-68.72	161.80	-55.64	171.77	-85.60	261.05	-72.52	271.02
Tangent	-48.87	270.96	-66.55	149.05	-53.47	159.02	-68.72	161.80	-55.64	171.77	-85.60	261.05	-72.52	271.02

Met Council PROPOSED LOW FLOOR LIGHT RAIL VEHICLE

TABLE 14A - VEHICLE DYNAMIC ENVELOPE - OUTSIDE OF CURVE

Cross Level Variation = 1.0 in
Superelevation = 6.0 in

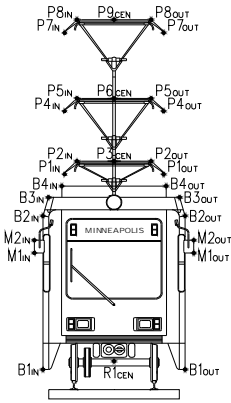

NOTES:

Coordinates shown are in english units (mm)

Maximum values for each radius are shown in Bold Italicized font

All coordinates shown are referenced from a point located at 1/2 track gauge and top of rail (0,0)

Superelevation is applied relative to top of low rail

Points R1CEN, P3CEN, P6CEN and P9CEN are not specific to either Outside or Inside of curve

B# = LFLRV Body Points

M# = LFLRV Mirror Points

P# = LFLRV Pantograph Points

R# = LFLRV Roll Center Point

File Name: MIN-S.XLS

Revision By: SCA

Revision Date: 02/22/99

RADIUS FEET	R1CEN		B1OUT		M1OUT		M2OUT		B2OUT		B3OUT		B4OUT	
	X	Y	X	Y	X	Y	X	Y	X	Y	X	Y	X	Y
82	-1.97	18.43	74.93	11.84	79.02	101.01	78.88	120.20	72.99	137.22	59.13	150.53	53.83	157.01
100	-1.97	18.43	71.03	11.84	75.98	101.01	75.84	120.20	69.09	137.22	57.44	150.53	51.35	157.01
150	-1.97	18.43	64.82	11.84	71.08	101.01	70.94	120.20	62.88	137.22	54.72	150.53	47.42	157.01
200	-1.97	18.43	61.59	11.84	68.51	101.01	68.37	120.20	59.65	137.22	53.29	150.53	45.38	157.01
300	-1.97	18.43	58.27	11.84	65.85	101.01	65.71	120.20	56.33	137.22	51.81	150.53	43.29	157.01
400	-1.97	18.43	57.44	11.84	64.49	101.01	64.35	120.20	55.50	137.22	51.05	150.53	42.23	157.01
500	-1.97	18.43	56.98	11.84	63.66	101.01	63.53	120.20	55.04	137.22	50.59	150.53	41.59	157.01
600	-1.97	18.43	56.67	11.84	63.11	101.01	62.97	120.20	54.73	137.22	50.28	150.53	41.16	157.01
700	-1.97	18.43	56.45	11.84	62.71	101.01	62.57	120.20	54.51	137.22	50.05	150.53	40.85	157.01
800	-1.97	18.43	56.28	11.84	62.41	101.01	62.27	120.20	54.34	137.22	49.88	150.53	40.61	157.01
900	-1.97	18.43	56.15	11.84	62.18	101.01	62.04	120.20	54.21	137.22	49.75	150.53	40.43	157.01
1000	-1.97	18.43	56.04	11.84	61.99	101.01	61.85	120.20	54.10	137.22	49.65	150.53	40.29	157.01
1200	-1.97	18.43	55.89	11.84	61.71	101.01	61.57	120.20	53.94	137.22	49.49	150.53	40.07	157.01
1500	-1.97	18.43	55.73	11.84	61.43	101.01	61.29	120.20	53.79	137.22	49.33	150.53	39.85	157.01
2000	-1.97	18.43	55.57	11.84	61.14	101.01	61.00	120.20	53.63	137.22	49.17	150.53	39.63	157.01
5000	-1.97	18.43	55.28	11.84	60.63	101.01	60.49	120.20	53.34	137.22	48.89	150.53	39.24	157.01
10000	-1.97	18.43	55.18	11.84	60.46	101.01	60.32	120.20	53.24	137.22	48.79	150.53	39.10	157.01
50000	-1.97	18.43	55.11	11.84	60.32	101.01	60.18	120.20	53.17	137.22	48.71	150.53	39.00	157.01
Tangent	-1.97	18.43	55.09	11.84	60.29	101.01	60.15	120.20	53.15	137.22	48.69	150.53	38.97	157.01

RADIUS FEET	P3CEN		P1OUT		P2OUT		P4OUT		P5OUT		P7OUT		P8OUT	
	X	Y	X	Y	X	Y	X	Y	X	Y	X	Y	X	Y
82	-32.45	159.42	39.94	154.35	24.80	161.45	39.76	166.88	24.62	174.05	38.34	264.54	23.20	272.56
100	-32.45	159.42	39.94	154.35	24.80	161.45	39.76	166.88	24.62	174.05	38.34	264.54	23.20	272.56
150	-32.45	159.42	39.94	154.35	24.80	161.45	39.76	166.88	24.62	174.05	38.34	264.54	23.20	272.56
200	-32.45	159.42	39.94	154.35	24.80	161.45	39.76	166.88	24.62	174.05	38.34	264.54	23.20	272.56
300	-32.45	159.42	39.94	154.35	24.80	161.45	39.76	166.88	24.62	174.05	38.34	264.54	23.20	272.56
400	-32.45	159.42	39.94	154.35	24.80	161.45	39.76	166.88	24.62	174.05	38.34	264.54	23.20	272.56
500	-32.45	159.42	39.94	154.35	24.80	161.45	39.76	166.88	24.62	174.05	38.34	264.54	23.20	272.56
600	-32.45	159.42	39.94	154.35	24.80	161.45	39.76	166.88	24.62	174.05	38.34	264.54	23.20	272.56
700	-32.45	159.42	39.94	154.35	24.80	161.45	39.76	166.88	24.62	174.05	38.34	264.54	23.20	272.56
800	-32.45	159.42	39.94	154.35	24.80	161.45	39.76	166.88	24.62	174.05	38.34	264.54	23.20	272.56
900	-32.45	159.42	39.94	154.35	24.80	161.45	39.76	166.88	24.62	174.05	38.34	264.54	23.20	272.56
1000	-32.45	159.42	39.94	154.35	24.80	161.45	39.76	166.88	24.62	174.05	38.34	264.54	23.20	272.56
1200	-32.45	159.42	39.94	154.35	24.80	161.45	39.76	166.88	24.62	174.05	38.34	264.54	23.20	272.56
1500	-32.45	159.42	39.94	154.35	24.80	161.45	39.76	166.88	24.62	174.05	38.34	264.54	23.20	272.56
2000	-32.45	159.42	39.94	154.35	24.80	161.45	39.76	166.88	24.62	174.05	38.34	264.54	23.20	272.56
5000	-32.45	159.42	39.94	154.35	24.80	161.45	39.76	166.88	24.62	174.05	38.34	264.54	23.20	272.56
10000	-32.45	159.42	39.94	154.35	24.80	161.45	39.76	166.88	24.62	174.05	38.34	264.54	23.20	272.56
50000	-32.45	159.42	39.94	154.35	24.80	161.45	39.76	166.88	24.62	174.05	38.34	264.54	23.20	272.56
Tangent	-32.45	159.42	39.94	154.35	24.80	161.45	39.76	166.88	24.62	174.05	38.34	264.54	23.20	272.56

Met Council PROPOSED LOW FLOOR LIGHT RAIL VEHICLE

TABLE 14B - VEHICLE DYNAMIC ENVELOPE - INSIDE OF CURVE

Cross Level Variation = 1.0 in
Superelevation = 6.0 in

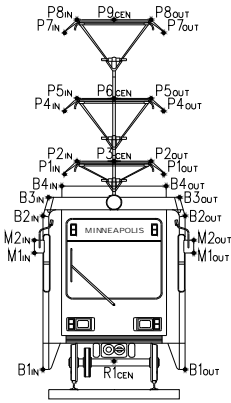

RADIUS FEET	P6 _{CEN}		B1 _{IN}		M1 _{IN}		M2 _{IN}		B2 _{IN}		B3 _{IN}		B4 _{IN}	
	X	Y	X	Y	X	Y	X	Y	X	Y	X	Y	X	Y
82	-34.83	172.17	-72.33	1.35	-87.10	87.72	-88.92	110.09	-92.48	128.67	-90.98	143.08	-82.86	151.69
100	-34.83	172.17	-69.50	1.35	-84.27	87.72	-86.09	110.09	-89.65	128.67	-88.15	143.08	-80.03	151.69
150	-34.83	172.17	-65.23	1.35	-80.00	87.72	-81.82	110.09	-85.38	128.67	-83.89	143.08	-75.76	151.69
200	-34.83	172.17	-63.11	1.35	-77.88	87.72	-79.70	110.09	-83.26	128.67	-81.77	143.08	-73.64	151.69
300	-34.83	172.17	-61.00	1.35	-75.77	87.72	-77.59	110.09	-81.15	128.67	-79.65	143.08	-71.53	151.69
400	-34.83	172.17	-59.94	1.35	-74.82	87.72	-76.64	110.09	-80.09	128.67	-78.59	143.08	-70.47	151.69
500	-34.83	172.17	-59.31	1.35	-75.71	87.72	-77.53	110.09	-79.46	128.67	-77.96	143.08	-69.84	151.69
600	-34.83	172.17	-58.88	1.35	-76.30	87.72	-78.12	110.09	-79.04	128.67	-77.54	143.08	-69.42	151.69
700	-34.83	172.17	-58.58	1.35	-76.72	87.72	-78.54	110.09	-78.74	128.67	-77.24	143.08	-69.12	151.69
800	-34.83	172.17	-58.36	1.35	-77.04	87.72	-78.86	110.09	-78.51	128.67	-77.01	143.08	-68.89	151.69
900	-34.83	172.17	-58.18	1.35	-77.28	87.72	-79.10	110.09	-78.33	128.67	-76.84	143.08	-68.71	151.69
1000	-34.83	172.17	-58.04	1.35	-77.48	87.72	-79.29	110.09	-78.19	128.67	-76.70	143.08	-68.57	151.69
1200	-34.83	172.17	-57.83	1.35	-77.77	87.72	-79.59	110.09	-77.98	128.67	-76.48	143.08	-68.36	151.69
1500	-34.83	172.17	-57.62	1.35	-78.06	87.72	-79.88	110.09	-77.77	128.67	-76.27	143.08	-68.15	151.69
2000	-34.83	172.17	-57.41	1.35	-78.35	87.72	-80.16	110.09	-77.56	128.67	-76.06	143.08	-67.94	151.69
5000	-34.83	172.17	-57.50	1.35	-78.86	87.72	-80.68	110.09	-77.66	128.67	-76.16	143.08	-68.24	151.69
10000	-34.83	172.17	-57.60	1.35	-79.04	87.72	-80.86	110.09	-77.75	128.67	-76.26	143.08	-68.37	151.69
50000	-34.83	172.17	-57.68	1.35	-79.17	87.72	-80.99	110.09	-77.83	128.67	-76.33	143.08	-68.48	151.69
Tangent	-34.83	172.17	-57.70	1.35	-79.21	87.72	-81.03	110.09	-77.85	128.67	-76.35	143.08	-68.50	151.69

NOTES:

Coordinates shown are in english units (mm)

Maximum values for each radius are shown in Bold Italicized font

All coordinates shown are referenced from a point located at 1/2 track gauge and top of rail (0,0)

Superelevation is applied relative to top of low rail

Points R1_{CEN}, P3_{CEN}, P6_{CEN} and P9_{CEN} are not specific to either Outside or Inside of curve

B# = LFLRV Body Points

M# = LFLRV Mirror Points

P# = LFLRV Pantograph Points

R# = LFLRV Roll Center Point

File Name: MIN-S.XLS

Revision By: SCA

Revision Date: 02/22/99

RADIUS FEET	P9 _{CEN}		P1 _{IN}		P2 _{IN}		P4 _{IN}		P5 _{IN}		P7 _{IN}		P8 _{IN}	
	X	Y	X	Y	X	Y	X	Y	X	Y	X	Y	X	Y
82	-53.34	271.41	-68.90	148.86	-56.03	159.08	-71.27	161.61	-58.40	171.83	-89.79	260.85	-76.92	271.07
100	-53.34	271.41	-68.90	148.86	-56.03	159.08	-71.27	161.61	-58.40	171.83	-89.79	260.85	-76.92	271.07
150	-53.34	271.41	-68.90	148.86	-56.03	159.08	-71.27	161.61	-58.40	171.83	-89.79	260.85	-76.92	271.07
200	-53.34	271.41	-68.90	148.86	-56.03	159.08	-71.27	161.61	-58.40	171.83	-89.79	260.85	-76.92	271.07
300	-53.34	271.41	-68.90	148.86	-56.03	159.08	-71.27	161.61	-58.40	171.83	-89.79	260.85	-76.92	271.07
400	-53.34	271.41	-68.90	148.86	-56.03	159.08	-71.27	161.61	-58.40	171.83	-89.79	260.85	-76.92	271.07
500	-53.34	271.41	-68.90	148.86	-56.03	159.08	-71.27	161.61	-58.40	171.83	-89.79	260.85	-76.92	271.07
600	-53.34	271.41	-68.90	148.86	-56.03	159.08	-71.27	161.61	-58.40	171.83	-89.79	260.85	-76.92	271.07
700	-53.34	271.41	-68.90	148.86	-56.03	159.08	-71.27	161.61	-58.40	171.83	-89.79	260.85	-76.92	271.07
800	-53.34	271.41	-68.90	148.86	-56.03	159.08	-71.27	161.61	-58.40	171.83	-89.79	260.85	-76.92	271.07
900	-53.34	271.41	-68.90	148.86	-56.03	159.08	-71.27	161.61	-58.40	171.83	-89.79	260.85	-76.92	271.07
1000	-53.34	271.41	-68.90	148.86	-56.03	159.08	-71.27	161.61	-58.40	171.83	-89.79	260.85	-76.92	271.07
1200	-53.34	271.41	-68.90	148.86	-56.03	159.08	-71.27	161.61	-58.40	171.83	-89.79	260.85	-76.92	271.07
1500	-53.34	271.41	-68.90	148.86	-56.03	159.08	-71.27	161.61	-58.40	171.83	-89.79	260.85	-76.92	271.07
2000	-53.34	271.41	-68.90	148.86	-56.03	159.08	-71.27	161.61	-58.40	171.83	-89.79	260.85	-76.92	271.07
5000	-53.34	271.41	-68.90	148.86	-56.03	159.08	-71.27	161.61	-58.40	171.83	-89.79	260.85	-76.92	271.07
10000	-53.34	271.41	-68.90	148.86	-56.03	159.08	-71.27	161.61	-58.40	171.83	-89.79	260.85	-76.92	271.07
50000	-53.34	271.41	-68.90	148.86	-56.03	159.08	-71.27	161.61	-58.40	171.83	-89.79	260.85	-76.92	271.07
Tangent	-53.34	271.41	-68.90	148.86	-56.03	159.08	-71.27	161.61	-58.40	171.83	-89.79	260.85	-76.92	271.07