

# **Business Item 2020-68 SW: High Strength Waste Hauling Services**

Heidi Hutter, Principal Engineer, Plant Engineering, Technical Services

Environment Committee: February 11, 2020



# Background

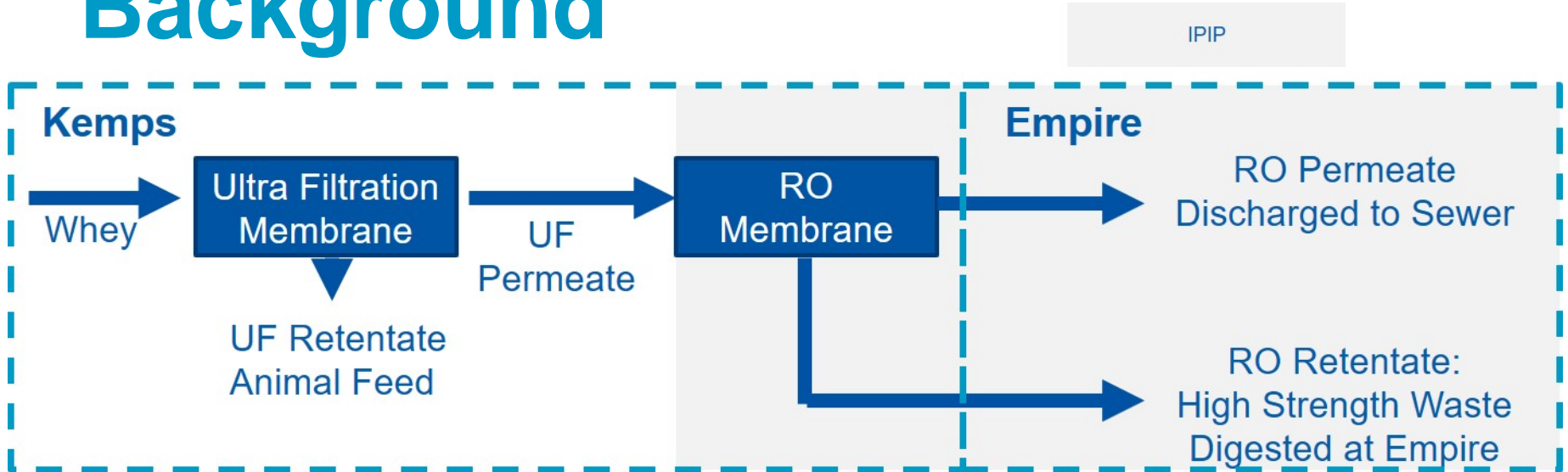

## MCES Benefits

- ✓ Defers Capital Expenditure
- ✓ Avoids Operating Costs

## Kemps Benefits

- ✓ Reduce/Eliminate Strength Charge
- ✓ Water Reuse
- ✓ Increase Production

## Regional Benefits

- ✓ Efficient and Sustainable Services
- ✓ Water Reuse
- ✓ Industrial Expansion

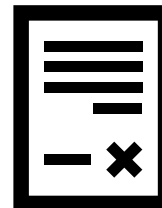

- 10-yr Agreement
- RO MCES Owned
- MCES Takes all RO Retentate
- RO Performance Determines Annual Loan Repayment
  - Up to 30% Discount

# Background



RO System at Kemp's



Receiving Station at Empire

# Bid Summary

- 3 bids received January 16, 2020, ranged from \$1,598,740.00 to \$2,427,930.
- Disadvantaged Business Participation Goals: 0%
- Schlomka's Vac Truck Services
  - Low responsive, responsible bid \$1,598,740.00.
  - Met Metropolitan Council Underutilized Business (MCUB) participation goals

# Proposed Action

- That the Metropolitan Council authorize execution of contract 19P371 with Schlomka's Vac Truck Services, Inc. in an amount not to exceed \$2,000,000 for a period of five (5) years for hauling high strength waste from Kemps LLC, located in Farmington, MN to the Empire Wastewater Treatment Plant for digestion.

# Questions

Heidi Hutter  
Principal Engineer, Plant Engineering  
Technical Services  
Heidi.Hutter@metc.state.mn.us  
651-602-1026