

**Business Item 2021-119:**  
**Interceptor 1-MN-341 Pipe-in-Pipe**  
**Rehabilitation, Contract 21P064**

Jeff Schwarz, Minneapolis Area Program Manager, Interceptor Engineering

Environment Committee: May 11, 2021



# Project Location



# PIP Condition

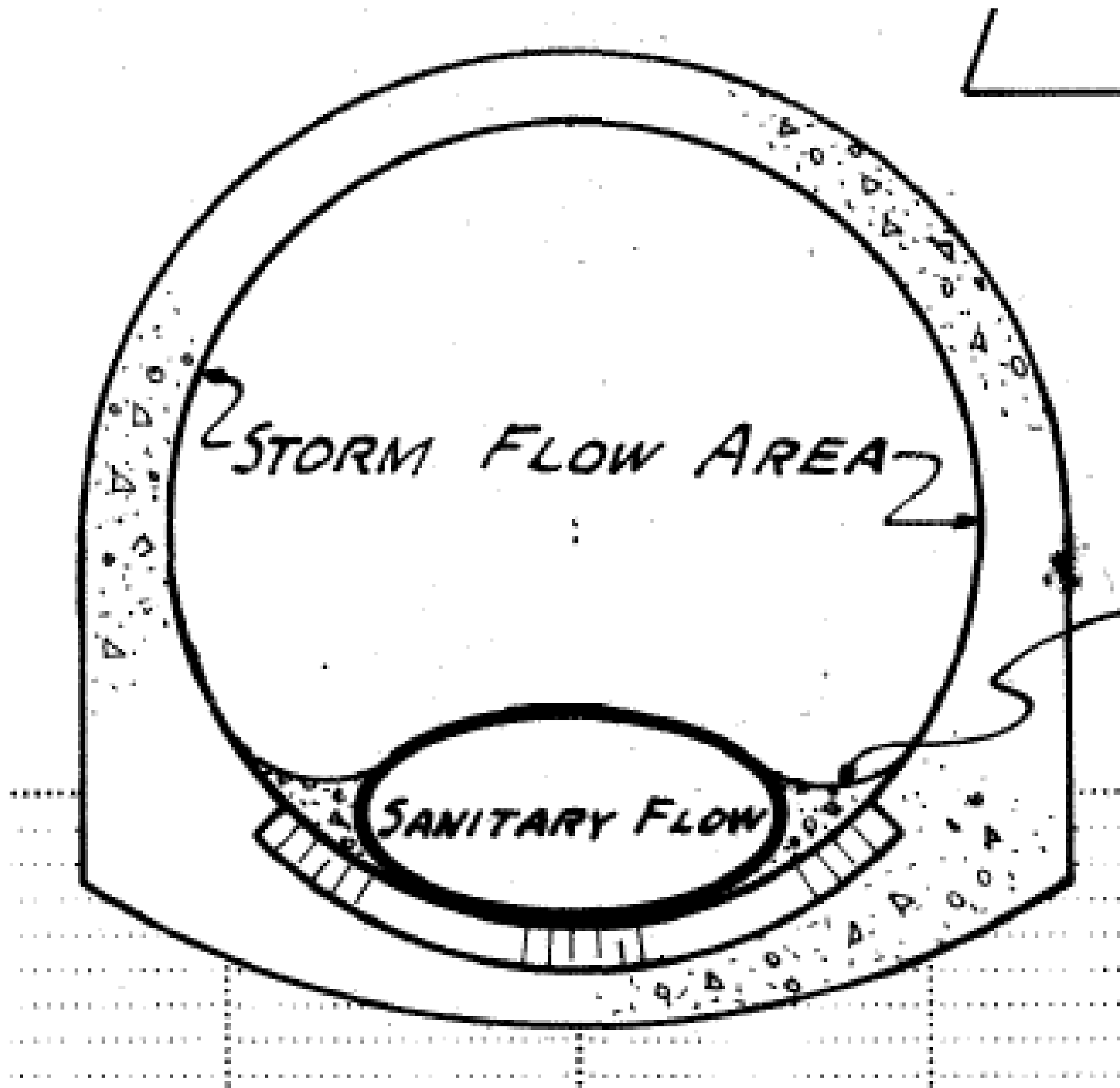

Pipe-in-Pipe



CMP Damage

# PIP Repair

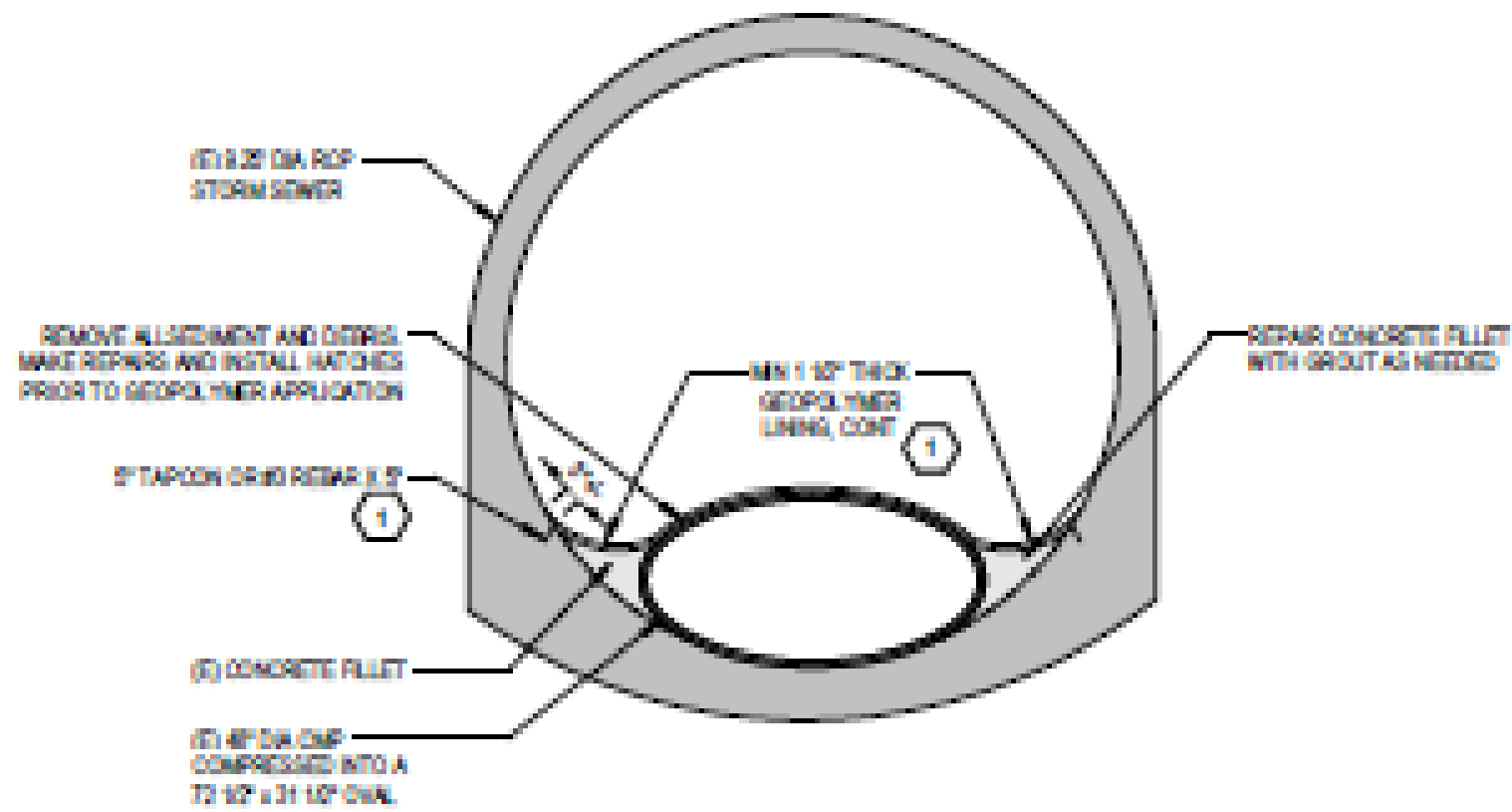

## Geopolymer Mat

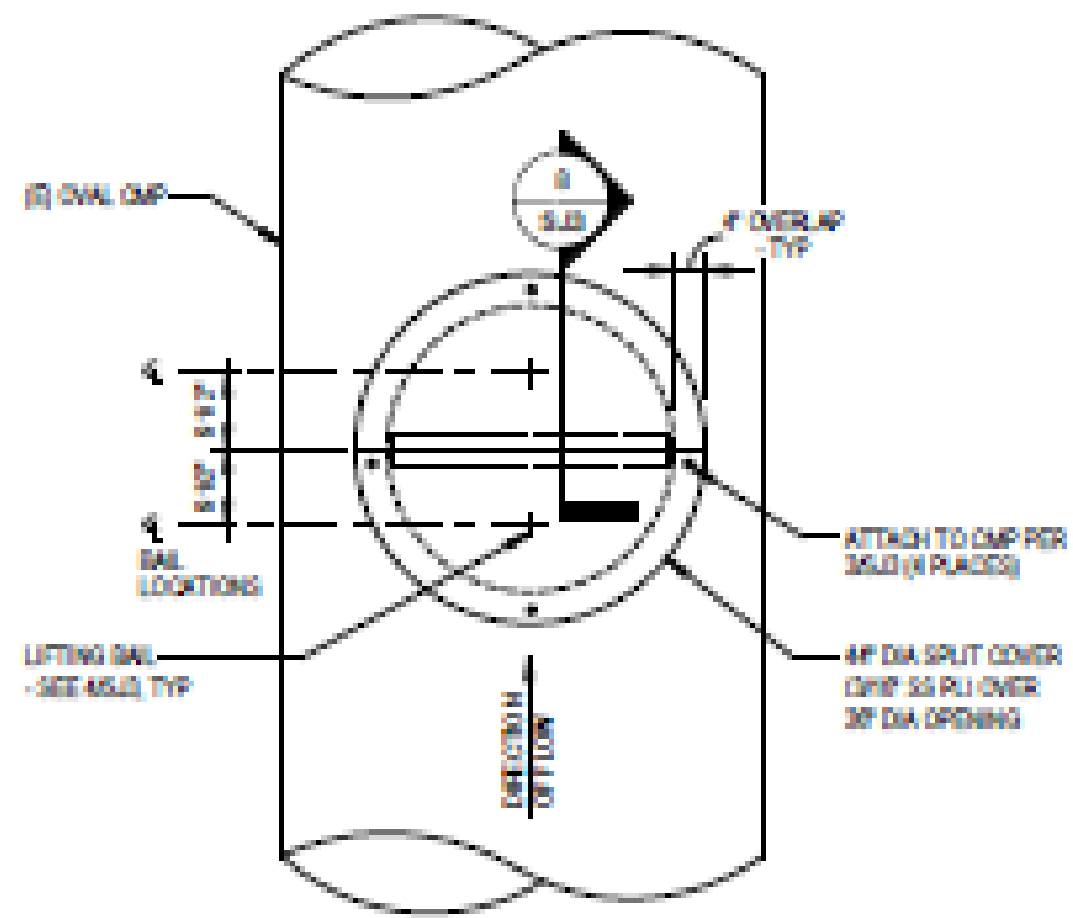

## CMP Hatch

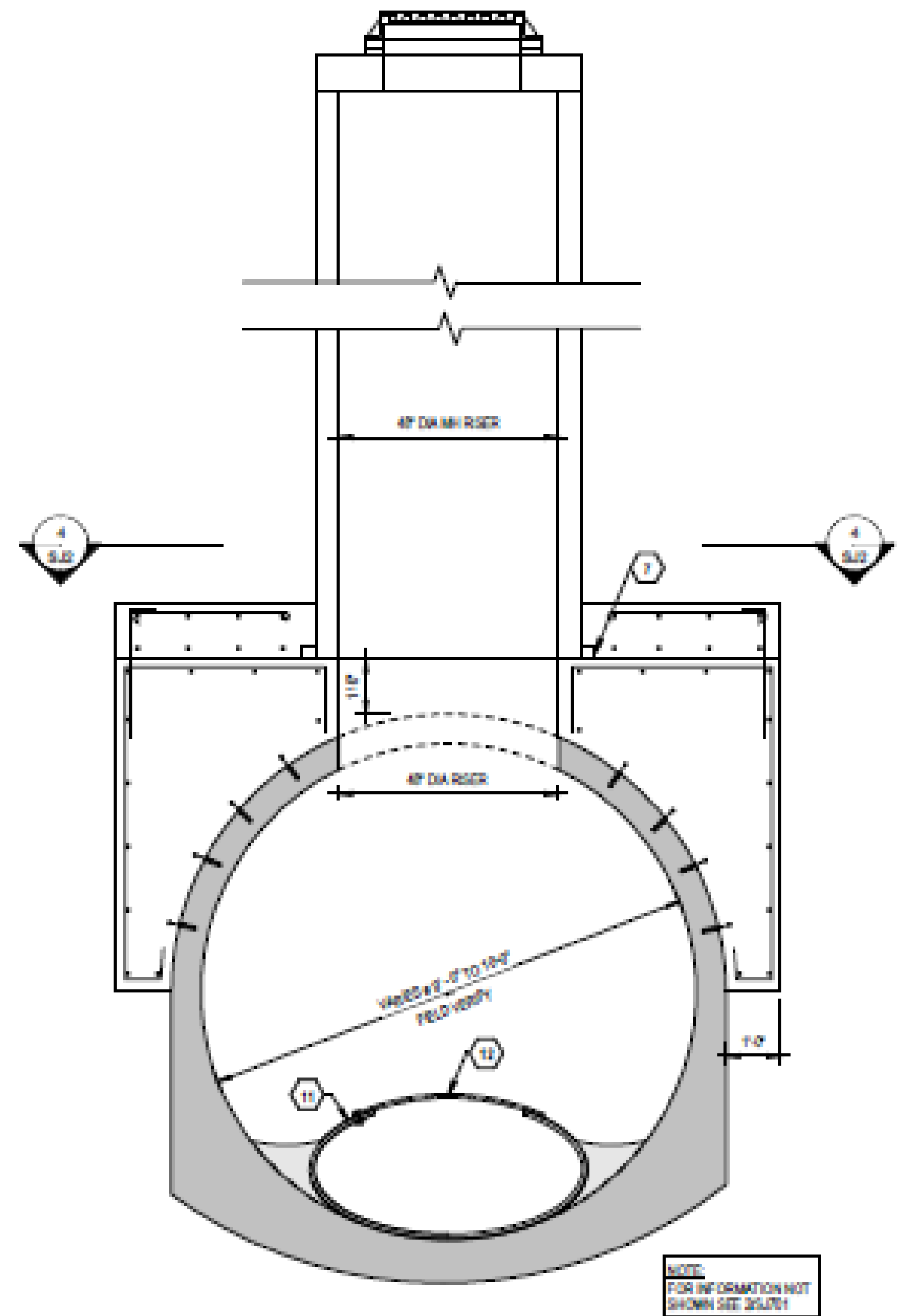

## Access Structure

# Bid Results

- Seven bids received
- Bid Range: \$6,508,850 to \$11,195,893
- Metropolitan Council Underutilized Business goal of 6%
- PciRoads was the lowest, responsive responsible bidder at \$6,508,850 and committed to 6.03% numeric goal

# Proposed Action

That the Metropolitan Council authorize its Regional Administrator to award and execute a contract for Interceptor 1-MN-341 pipe-in-pipe rehabilitation project 807618, contract 21P064 to PCiRoads, LLC, to install thirteen maintenance holes and rehabilitate 8,200 feet of “pipe-in-pipe” interceptor, in an amount not to exceed \$6,508,850.

# Questions

Jeff Schwarz

Minneapolis Area Program Manager

Interceptor Engineering

Wastewater Planning & Capital Project Delivery

[Jeffrey.Schwarz@metc.state.mn.us](mailto:Jeffrey.Schwarz@metc.state.mn.us)

651-602-1176