

ACTION TRANSMITTAL No. 2013-34

DATE: September 5, 2013

TO: Transportation Advisory Board

FROM: Technical Advisory Committee

PREPARED BY: Heidi Schallberg, Senior Planner (651-602-1721)

SUBJECT: Scope Change Request for Bridge No. 9 over the Mississippi River at the University of Minnesota

REQUESTED ACTION: The City of Minneapolis requests a scope change to modify the scope of the Bridge No. 9 project over the Mississippi River to Pier 3 concrete repair and installation of full height concrete encasement.

RECOMMENDED MOTION: Recommend of the request to modify the scope for SP#141-090-038 Bridge No. 9 over the Mississippi River to Pier 3 concrete repair and installation of full height concrete encasement on the condition that the city provide a letter of commitment to completing the other project elements in the original application within three years without seeking federal funding through TAB for that work.

BACKGROUND AND PURPOSE OF ACTION: In the 2009 solicitation, the City of Minneapolis received \$1,040,000 in Transportation Enhancements funding for this project. The city is requesting a scope change based on information from a more recent field evaluation of the bridge. The city's request and supporting information are attached.

RELATIONSHIP TO REGIONAL POLICY: Projects that receive funding through the regional solicitation process are subject to the regional scope change policy. The purpose of this policy is to ensure that the project is designed and constructed according to the plans and intent described in the original application. Additionally, federal rules require that any federally-funded project scope change must go through a formal review and TIP amendment process if the project description or total project cost changes substantially. The scope change policy and process allow project sponsors to make adjustments to their projects as needed while still providing substantially the same benefits described in their original project applications.

STAFF ANALYSIS: Staff reviewed the scope change request submitted by the city. Additional testing done in 2012 after funding was awarded found that emergency repairs were needed for two of the bridge piers, and that work was completed in 2012 and 2013. Additional work will need to be done for these two piers beyond these emergency repairs. The 2009 condition study report indicated that Pier 3 was the one in most need of repair. This scope change request would allow the work to focus on this pier, which is consistent with the intent of the application to "preserve the structural integrity of the bridge." Based on the new information about the bridge condition, it would be difficult to re-evaluate the project application and recalculate scores in retrospect. In the 2009 solicitation, the project scored 675 points out of 1,000 and was ranked 9 out of 28

selected projects and 55 applications. The purpose of the project with the requested scope change remains consistent with the original application. Based on the information provided by the city, staff recommends approval of the requested scope change.

COMMITTEE COMMENTS AND ACTION: The Funding & Programming Committee was concerned about the five items in the original application being completed since they would not be completed with the federal funding with this scope change. The original intent of the project to preserve the structural integrity of the bridge would still be accomplished, but the change is requested in light of the additional extensive work found to be needed with additional testing. The committee discussed how historic bridges are different projects and can be difficult to predict costs for work. Some members were concerned about this opening the door for future requests, making the point that a road project that had a scope change request to remove elements important in the consideration of the application would likely have had its federal funding reduced. There were concerns about the city coming back to ask for federal funding in the future for some of the project elements that would not be done with federal funding in this project with the scope change. To address those concerns, the city committed to providing a letter as documentation that it commits to doing the bridge work originally outlined in the application without additional federal funding through TAB; the city may pursue federal funding for other work needed for the bridge in the future. This is consistent with the committee's action for a previous scope change in Ramsey. The committee approved the scope change request with one vote against as long as the city provided its letter, which is attached.

The Technical Advisory Committee was concerned that the city's letter of commitment to completing the other project elements in the original application did not indicate a timeframe for completing the work. The motion was amended that the city complete the project in three years, and the city agreed to this change. The motion was approved as amended.

ROUTING

TO	ACTION REQUESTED	DATE COMPLETED
TAC Funding & Programming Committee	Review & Recommend	August 15, 2013
Technical Advisory Committee	Review & Recommend	September 4, 2013
Transportation Advisory Board	Review & Adopt	
Metropolitan Council Transportation Committee	Concurrence	
Metropolitan Council	Concurrence	



**Department of
Public Works**
Steven A. Kotke, P.E.
City Engineer
Director

350 South 5th Street - Room 203
Minneapolis MN 55415

Office 612 673-3000
Fax 612 673-3565
TTY 612 673-2157

August 6, 2013

Mr. Karl Keel, Chair
Funding & Programming
Metropolitan Transportation Advisory Committee
Metropolitan Council
390 Robert Street North
Saint Paul, MN 55101 -1805

RE: TE-09-13 - Bridge No. 9 (MnDOT 94246)
Bridge 9 over the Mississippi River Substructure Rehabilitation
and Superstructure Painting Scope Change
SP 141-090-038

Dear Mr. Keel:

The City of Minneapolis wishes to request a scope change for our Bridge 9 project. During our 2012 field evaluation, the City found that the sub-structure's deterioration was significantly greater than anticipated in our 2009 Bridge Condition Report. The integrity of two the piers required a NBIS critical finding and emergency repairs were immediately begun to avoid closure. Based on findings, we are requesting that the scope be changed to Pier 3 Concrete Repairs & Full Height Concrete Encasement.

Your committee's consideration of our request is greatly appreciated.

Sincerely,

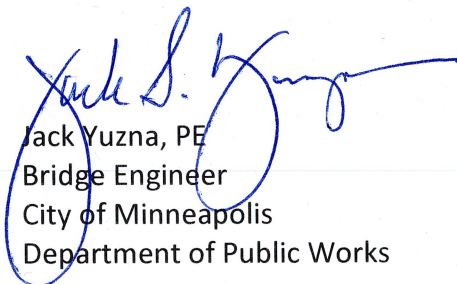

Jack Yuzna, PE
Bridge Engineer
City of Minneapolis
Department of Public Works



1. Background

Bridge No. 9 is a converted railroad bridge which carries pedestrian and bicycle traffic over the Mississippi River and West River Parkway between the University of Minnesota East and West Bank campuses in Minneapolis. A two span deck truss crosses the river. Three plate girder approach spans are located on the West Bank and two plate girder approaches are located on the East Bank. The bridge was originally constructed as a Northern Pacific Railroad crossing in the late 1880's. Portions of the current bridge date back to this original construction. It was reconstructed by the railroad in 1922. In 1999 the bridge was renovated for pedestrian use, opening for traffic in 2000. The City of Minneapolis (City) is the current owner. A location map is attached. Bridge No.9 also carries the University of Minnesota (U of M) main steam line to its West Bank Campus.

2. Original Scope

Following a Condition Study Report by SEH in March 2009, Minneapolis submitted an application for Federal Transportation Enhancement funds to address rehabilitation items identified in the report. Titled Bridge No. 9 (MnDOT Bridge 94246) Rehabilitation and Painting, Application No. TE-09-13 was approved for Program Year 2014. This application listed the following repair items identified in the 2009:

Item No.	Description	Estimated Cost
1	Pier Repairs	\$412,000
2	Approach Spans Waterproofing and Ballast Curb Repairs	\$319,000
3	Abutment Repairs	\$25,000
4	Repair and Partial Paint Steel Superstructure and Clean/Repair Bearings	\$449,000
5	Install "No Vehicles Allowed " Sign	\$500
	Total	\$1,205,500

Portions of the 2009 Condition Study Report were attached to the Transportation Enhancement Fund Application. Section 6.0 Summary of Project Costs indicated "These Items preserve the structural integrity of the bridge by repairing the deteriorated features with the most urgent need for repair."

3. Scope Change

Once funding was secured, the City retained Olson & Nesvold Engineers in 2012 to perform field and laboratory testing, collect geotechnical information and provide updated repair recommendations in advance of development of repair plans. In the course of this work a critical finding, related to bearing support conditions, was discovered. Concrete core samples and other forensic work revealed the lack of confining reinforcement at the piers and bearing supports. The piers were found to require more extensive repairs than the anticipated in the 2009 report.

The City directed ONE to develop repair plans to address the critical finding. Emergency repairs were immediately initiated to address pier & bearing support conditions at Pier 4 (river pier) and Pier 2 (see attached Elevation Plan for pier locations) to allow pedestrian traffic to remain on the bridge. This work was completed by City of Minneapolis forces in fall & winter of 2012 and 2013. The cost of the work exceeded \$700,000.

The repairs required at Pier 4 and Pier 2 are more extensive than the anticipated in the 2009 report. Concrete encasement was provided at Pier 4 from the top of cofferdam to the pier cap to prevent truss bearing support failure. A post-tensioned steel clamping fixture was installed at Pier 2 to accomplish the same objective. Additional work is necessary at both piers to complete these repairs. At Pier 4 a deep foundation system is needed to underpin the concrete encasement. At Pier 2 concrete encasement is required for the full height of the pier column to provide a permanent solution.

Bearing support is also a concern for Piers 2 and 3 (east bank piers). Full height concrete encasement should be installed at these locations. Additional pier cap deterioration or concrete cracking at Pier 2 or Pier 3 could necessitate bridge closure if these repairs are not completed on a timely basis.

The 2009 report indicated that Pier 3 (east bank river pier) was in greatest need of repair. With critical finding at Pier 2 & 4 addressed, the City proposes to focus on repairs to Pier 3. Full concrete encasement of the pier will require that lateral support around the pier and within the river to the bottom of the spread footing at bedrock. The site has extremely limited working area. There is a steam line vertical shaft house built abutting the east pier face as well as other underground steam and electrical utilities. Given the condition of the pier and the complexities of making the repairs within the site; the City proposes to re-scope the project to Pier 3 concrete repairs & full height encasement.

4. Revised Project Description

The conditions of the bridge's piers were far worse than anticipated in the 2009 report. The City of Minneapolis has concluded that the strengthening of the piers and scope of work will require several years to program. Therefore the City of Minneapolis proposes the project description be changed to Pier 3 Concrete Repairs and Installation of Full Height Concrete Encasement. If additional local funding is available, Pier 3 bearings replacement would also be included in this project.

The extent of repairs and the type of work differs from the original funding application. However, the intended purpose to "preserve the structural integrity of the bridge by repairing the deteriorated features with the most urgent need for repair" is consistent with the original application.

5. Additional Work

After Pier 3 repairs, future projects will be required to address the following issues:

- Pier 4 underpinning to provide foundation support for the concrete encasement emergency repair completed by Minneapolis in 2012 & 2013.
- Pier 5 concrete encasement.
- Pier 2 concrete encasement.
- Abutment 1 footing stabilization.
- Bearing rehabilitation.
- Deck repairs.
- Bridge painting including superstructure and railings.

6. Revised Cost Estimate – Pier 3 Repairs Encasement

Item	Estimated Cost
Concrete Encasement	\$800,000
Excavation Support	\$450,000
Bearing Rehabilitation	\$70,000
Total	\$1,320,000

CITY OF MINNEAPOLIS PROJECT NO. SP 141-090-038
BRIDGE NO. 9 OVER MISSISSIPPI RIVER AND WEST RIVER PARKWAY



Plotted by: dan.streeter
Plotted on: 8/5/2013 at 9:13:18 AM
File path: \\SBS\Public\projects\1036-1-Mpls No. 9\2 - production\c - work\Exhibit\Bridge No 9 Site Location.dgn



Olson & Nesvold Engineers, P.S.C.
7825 Washington Ave. S., Suite 100
Bloomington, MN 55439-2431

TOWNSHIP 29N
RANGE 24W
SECTION 24

SITE LOCATION
SCOPE CHANGE
BRIDGE NO. 9 PEDESTRIAN BRIDGE
MINNEAPOLIS, MINNESOTA

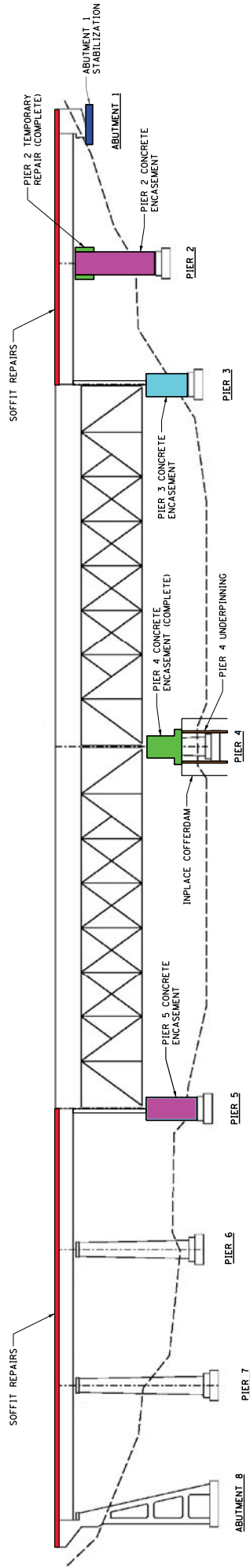

ELEVATION

SEQUENCE

- 1. PIER 4 ENCASUREMENT AND PIER 2 TEMPORARY REPAIR - COMPLETED WORK
- 2. PIERS 3 ENCASUREMENT - BID FEBRUARY 2014
- 3. PIER 4 UNDERPINNING - BID SCHEDULE DEPENDENT ON FUNDING
- 4. PIER 2 ENCASUREMENT - BID SCHEDULE DEPENDENT ON FUNDING
- 5. ABUTMENT 1 FOOTING STABILIZATION - BID SCHEDULE DEPENDENT ON FUNDING
- 6. SOFFIT REPAIRS - BID SCHEDULE DEPENDENT ON FUNDING

BRIDGE NO. 9 (MnDOT 94246)
CITY OF MINNEAPOLIS



August 23, 2013

**Department of
Public Works**
Steven A. Kotke, P.E.
City Engineer
Director

350 South 5th Street - Room 203
Minneapolis MN 55415

Office 612 673-3000
Fax 612 673-3565
TTY 612 673-2157

Pat Bursaw, Chair
Technical Advisory Committee to the TAB
Metropolitan Council
390 N Robert St
St Paul, MN 55101

**RE: Scope Change Request for TE-09-13 Bridge No 9 (MnDOT
94246) Bridge 9 over the Mississippi River Substructure
Rehabilitation and Superstructure Painting Scope Change
Request**

Dear Ms. Bursaw,

The City of Minneapolis is submitting this response letter to your attention as requested during the discussion of the above referenced topic at the Funding and Programming Committee on August 15, 2013. The City of Minneapolis wishes to request a scope change for our Bridge 9 project. Minneapolis asserts that the requested change in scope is necessary in order to address the most immediate structural deficiencies in the bridge structure; the change in scope is consistent with the original intent of our TE application which is to "preserve the structural integrity of the bridge".

Pursuant to the request made by the Funding and Programming Committee, Minneapolis is committed to maintaining the non-motorized function of this bridge which makes an important connection between Downtown and the U of M for both pedestrians and bicyclists. Counts conducted in 2010 show a combined 900 trips across this bridge daily, providing a non-motorized river crossing that directly connects to adjacent off-street facilities without requiring users to intermingle with vehicular traffic.

This bridge is nearly 100 years old and is eligible for nomination to the National Register of Historic Places. The City submitted its original TE application based upon a Condition Study Report dated March 2009. Once funding was secured, the City proceeded with field and laboratory testing which resulted in a critical finding related to the condition of the piers. In response, the City mobilized for immediate emergency repairs at a cost in excess of \$700,000. The requested scope change is aimed at continuing to address the concrete piers and is necessary in order to keep the bridge open.



Per the discussion at Funding and Programming, the City will commit to completing the remaining items identified in the original TE application with local funding but the timing of this work will be prioritized with the more immediate structural needs of the bridge. The City agrees that we will not seek further federal funding for the scope items that were part of the original TE application but acknowledge that we may seek outside funding, including federal funding, for future work associated with this bridge.

Sincerely,



Heidi Hamilton, P.E.
Deputy Director of Public Works
City of Minneapolis

Cc: Karl Keel, Chair Funding and Programming Committee
Council Member Lilligren, TAB Committee Member
Jack Yuzna
Jenifer Hager
Don Elwood



**2009 SUBMITTAL FOR:
FEDERAL TRANSPORTATION ENHANCEMENT FUNDING
BRIDGE NO. 9 OVER MISSISSIPPI RIVER**

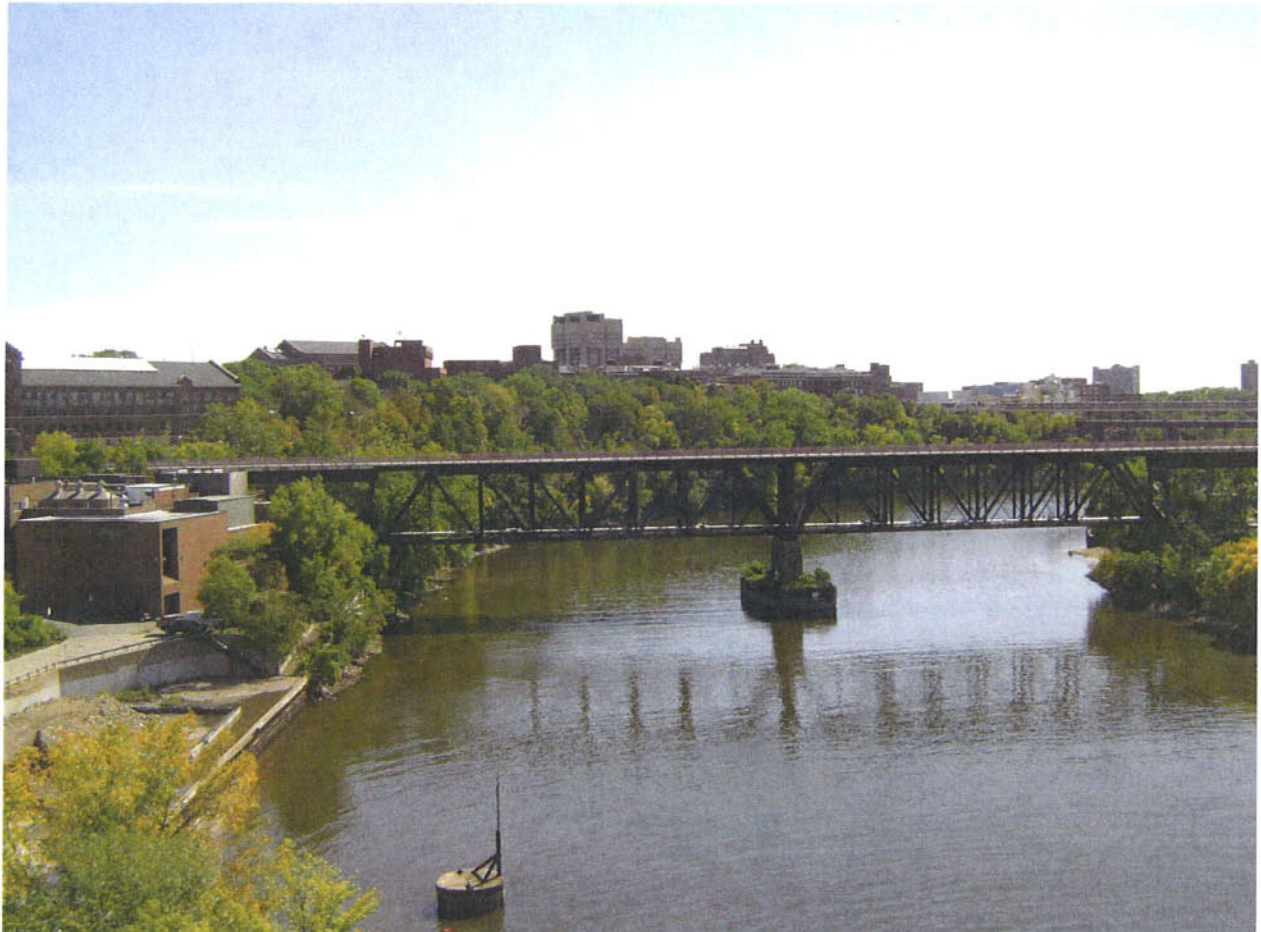

PREPARED BY:

CITY OF MINNEAPOLIS

JUNE 15, 2009

Bridge No. 9 Over Mississippi River
Federal Transportation Enhancement Funding

TABLE OF CONTENTS

Federal Funding Application Form	Page 1
Project Information (Form 2)	Page 2
Project Description	Page 3
Transportation Enhancements Qualifying Criteria Responses	Page 5
Transportation Enhancements Prioritizing Criteria Responses	Page 11

Attachments:

Attachment A - Project Location Maps

- Figure 1 - Project Location Map (Aerial)
- Figure 2 - Project Location Map (USGS)
- Figures 3 to 10 - Project Photos (Bridge)

Attachment B - Systems Maps

- Figure 1 - Minneapolis Bikeways Master Plan - 2001
- Figure 2 - Minneapolis Bikeways Master Plan – 2008 Draft
- Figure 3A – Minneapolis Multi-Modal Map
- Figure 3B – Minneapolis Multi-Modal Map (Downtown)

Attachment C - Minneapolis CIP Approved Project List

Attachment D - Project Exhibits

- Figure 1 – General Plan and Elevation
- Figure 2 – Typical Section
- Figure 3 – Typical Truss Section
- Figure 4 – Member Identification
- Figure 5 – Waterproofing Layout Plan
- Figure 6 – Waterproofing Details
- Figure 7 – Pier Details

Attachment E - Project Support Correspondence

Attachment F - MnDOT Structure Inventory and Inspection Reports for Bridge #94246

TABLE OF CONTENTS CONT.

Attachment G - Preliminary Project Cost Estimate

Attachment H - Appendix K / Project Implementation Schedule

Attachment I - Project Chronology

Attachment J – Condition Study Report: Bridge No. 9 Pedestrian Bridge Over Mississippi River

Federal Transportation Enhancement Fund Application

INSTRUCTIONS: Complete and return completed application to Kevin Roggenbuck, Transportation Coordinator, Transportation Advisory Board, 390 North Robert St., St. Paul, Minnesota 55101. (651) 602-1728. Form 1 needs to be filled out electronically. Please go to Metropolitan Council's website for instructions. **Applications must be received by 5:00 PM or postmarked on June 15, 2009. *Be sure to complete and attach the Project Information form. (Form 2)**

Office Use Only

I. GENERAL INFORMATION

1. APPLICANT: City of Minneapolis, Public Works

2. JURISDICTIONAL AGENCY (IF DIFFERENT):

3. MAILING ADDRESS: 309 2nd Ave. S., Room 300

CITY: Minneapolis

STATE: MN

ZIP CODE: 55401

4. COUNTY: Hennepin

5. CONTACT PERSON: Greg Schroeder

TITLE: Capital Projects Coordinator

PHONE NO.
(612) 673-3718

CONTACT E-MAIL ADDRESS: greg.schroeder@ci.minneapolis.mn.us

II. PROJECT INFORMATION

6. PROJECT NAME: Bridge 9 over the Mississippi River Substructure Rehabilitation and Superstructure Painting
(MN Bridge # 94246)

7. BRIEF PROJECT DESCRIPTION for database (Include location, road name, type of improvement, etc... A more complete description must be submitted later in the application):

The project proposes to rehabilitate and paint a pedestrian and bicycle bridge over the Mississippi River stretching from the east bank to the west bank of the University of Minnesota. Built in 1922, this 925' long steel deck truss structure provides service to the City's trail system for downtown commuter, U. of M. commuters and recreational users. In 1994, Woodward-Clyde conducted a historic evaluation of Bridge No. 9 (Mn/DOT S.P. 27-637-02, SHPO No. 94-2179). This historic evaluation determined that Bridge No. 9 is recommended eligible for nomination to the National Register of Historic Places.

8. TE PROJECT CATEGORY – Check only one project grouping in which you wish your project to be considered (see p. 85).

Environmental

Bicycle/Pedestrian

Streetscape

Historic/Archaeological

III. PROJECT FUNDING

9 Are you applying for funds from another source(s) to implement this project? Yes No

If yes, please identify the source(s): Federal STP Funding

10. FEDERAL AMOUNT: \$1,000,000

13. SOURCE OF MATCH FUNDS: Local Bonds

11. MATCH AMOUNT: \$250,000

14. MATCH % OF PROJECT TOTAL: 20%

12. PROJECT TOTAL: \$1,250,000

15. PROGRAM YEAR: 2013 2014

16. SIGNATURE

Steven Bosecker

17. TITLE: City Coordinator

PROJECT INFORMATION (Form 2)

(To be used to assign State Aid Project Number after project is selected)

Please fill in the following information as it pertains to your proposed project. Items that do not apply to your project, please label N/A. **Do not send this form to the State Aid Office. For project solicitation package only.**

COUNTY, CITY, OR LEAD AGENCY: City of Minneapolis COUNTY OR CITY NO.: N/A

FUNCTIONAL CLASS OF ROAD: Off Road Pedestrian and Bicycle Trail

ROAD SYSTEM: Off Road Pedestrian and Bicycle Trail (TH, CSAH, MSAS, CO. RD., TWP. RD., CITY STREET)

ROAD NO.: N/A

NAME OF ROAD: N/A (Example; 1st ST., MAIN AVE)

LOCATION: From: 20th Avenue South

To: River Road East (DO NOT INCLUDE LEGAL DESCRIPTION)

SECTION-TOWNSHIP-RANGE OF ONE END OF PROJECT: 24 - 029N - 24W

TYPE OF WORK: Rehabilitation of pier and abutment substructures and painting steel superstructure.

(Examples: GRADE, AGG BASE, BIT BASE, BIT SURF, SIDEWALK, CURB AND GUTTER, STORM SEWER, SIGNALS, LIGHTING, GUARDRAIL, BIKE PATH, PED RAMPS, ETC.)

BRIDGE/CULVERT PROJECTS

OLD BRIDGE /CULVERT NO.N/A NEW BRIDGE/CULVERT NO.94246

STRUCTURE IS OVER Mississippi River

NAME OF TWP.: N/A

PROJECT DESCRIPTION

Bridge No. 9, built in 1922 by the Northern Pacific Railroad, is a seven span steel deck truss bridge providing a railroad link between St. Paul and Minneapolis over the Mississippi River. Bridge No. 9, (Mn/DOT Bridge No 94246) consists of first and second generation structural components. In the late 1880's the Northern Pacific Railroad constructed a river crossing at the location of the Bridge No. 9. In 1922 a second bridge, Bridge No. 9, was constructed using portions of the original bridge. A center truss was added between the original (late 1880's) pair of trusses for the two main spans. Other original bridge members reused in the 1922 construction included: floor beams; stringers; lateral bracing; and truss expansion joints. The original approaches, the approach spans, and the substructure units were replaced in the 1922 construction resulting in a bridge structure consisting of three west approach spans of approximately 90 foot length on a curved horizontal alignment, two main spans of approximately 249 foot length on a tangent horizontal alignment, and two east approach spans of approximately 84 foot length. The total length of the bridge is 952 feet and the width is 24 feet. Reinforced concrete piers and abutments support the entire structure. When originally constructed, the bridge carried two sets of parallel tracks with simple pipe handrails along each side of the bridge.

In 1960, the University of Minnesota placed a steam line at the bottom chord level of the main truss spans. The steam line services the University's west bank buildings.

After 1966, rail traffic on Bridge No. 9 was confined to a single track and the other track was removed. By 1981, rail traffic ceased completely and the bridge structure was abandoned. In 1986, the abandoned structure (including the rail corridor right-of-way) was sold to the City of Minneapolis by Burlington Northern Railroad Company (now Burlington Northern Santa Fe Railroad Company).

In 1994, Woodward-Clyde conducted a historic evaluation of Bridge No. 9 (Mn/DOT S.P. 27-637-02, SHPO No. 94-2179). This historic evaluation determined that Bridge No. 9 is recommended eligible for nomination to the National Register of Historic Places.

In 1999, the bridge was remodeled and reopened to carry pedestrian traffic across the Mississippi River. The decks and the railings were reconstructed. The truss span's railroad decks were removed and replaced with a 27-foot wide, 7-inch thick concrete deck. In the approach spans, concrete rail parapets were placed adjacent to the existing concrete ballast slab curbs on both sides to permit anchorage of the new ornamental metal railing and light poles. Granular base fill topped with bituminous wearing course pavement was placed between the new concrete parapets in the existing ballast slabs of the approach spans. Ornamental railing and lights were added full length of the bridge on both sides.

Bridge No. 9 is classified as a Fracture Critical Bridge. The bridge has been routinely inspected as required by Mn/DOT. A Fracture Critical Bridge is defined as having at least one fracture critical member or member components. Fracture critical members are steel tension members whose failure would be expected to result in the collapse of the bridge.

A recent field inspection and condition study of Bridge No. 9 revealed the following:

- The concrete surfaces at the ends of the concrete caps for Piers 2 to 7 are deteriorated due to weathering and scaling. Reinforcing bars are exposed at a few pier locations. However, the concrete surfaces under the bearings are not affected to date.
- Water is leaking through the open longitudinal joints of the approach span ballast slab decks causing calcium deposit buildups to form and the steel plate girders adjacent to the joints to corrode.
- Concrete spalls with exposed rebar are located on the sides of the ballast slab and curb.
- The fixed and expansion bearing assemblies had some loose or bent anchor bolts and are dirty with excessive debris built up around the bearings.
- The paint system on the steel members is in poor condition with excessive loss of coating system.
- The main span steel deck trusses and the approach steel plate girders have coating systems containing lead.

- Structural rating analysis revealed that the truss is adequate to support the required 85 psf design live load for pedestrian and bicycle use in accordance with AASHTO Design Specifications. Since the bridge was originally designed for dual track railroad live load, the bridge components were also checked, rated, and found adequate for a single HS20 truck live load. No impact was applied to this single HS20 truck live load since the bridge is currently used to carry a multi-use trail for bicycles and pedestrians. Controlling members currently have minimal section loss due to corrosion. Members with light to moderate corrosion will be monitored during future routine bridge inspections.

Generally the bridge is in good condition but several items should be considered for immediate repair or rehabilitation, especially the concrete pier cap deterioration. Five rehabilitation items of most significance were identified. Estimates of project costs were determined for each of the five rehabilitation items and are presented in Attachment G. The five rehabilitation items are presented below:

- Item 1: Pier Repairs
- Item 2: Approach Spans Waterproofing and Ballast Curb Repairs
- Item 3: Abutment Repairs
- Item 4: Repair & Paint Steel Superstructure and Clean/Repair Bearings
- Item 5: Install “No Vehicles Allowed” Sign on North Approach

TRANSPORTATION ENHANCEMENTS PROJECTS - QUALIFYING CRITERIA

Projects must be coordinated with all affected communities and other levels and units of government. The applicant must show that the project meets each of the following ten qualifying criteria to qualify for scoring under the prioritizing criteria. Answer each criterion in a numbered sequence. **Failure to respond to any of the qualifying criteria will result in a recommendation to disqualify your project.**

1. Qualifying Activities. The applicant must show that the proposed project falls under at least one of the following list of twelve qualifying activities and must state the specific category(ies) the project qualifies under. The list of qualifying TE activities provided in 23 U.S.C. 101(a)(35) of SAFETEA-LU is intended to be exclusive, not illustrative. That is, **only** those activities listed therein are eligible as TE activities.
 1. **Provision of facilities for pedestrians and bicycles.**
 2. Provision of safety and educational activities for pedestrians and bicyclists.
 3. Acquisition of scenic easements and scenic or historic sites including historic battlefields.
 4. Scenic or historic highway programs (including the provision of tourist and welcome center facilities).
 5. Landscaping and other scenic beautification.
 6. **Historic preservation.**
 7. Rehabilitation and operation of historic transportation buildings, structures, or facilities (including historic railroad facilities and canals).
 8. **Preservation of abandoned railway corridors (including the conversion and use thereof for pedestrian or bicycle trails).**
 9. Inventory, control and removal of outdoor advertising.
 10. Archaeological planning and research.
 11. Environmental mitigation to address water pollution due to highway runoff or reduce vehicle-caused wildlife mortality while maintaining habitat connectivity.
 12. Establishment of transportation museums.

One or more of these activities must constitute at least 70% of the project cost. Unlisted ancillary activities such as paving a parking lot, constructing buildings or providing restrooms must constitute no more than 30% of the total project cost. Applicants whose project is part of a larger transportation project must provide a construction cost summary demonstrating that at least 70% of the project is eligible for Transportation Enhancement funds.

Many projects include a number of activities – some which are on this list and others that are not. Only those project activities that are on the list may be counted as TE activities. For example, a rest area might include a historic site purchased and developed as an interpretive site illustrating local history. The historic site purchase and development would qualify as a transportation enhancement activity.

Work that is made possible because a project presents an opportunity to improve and enhance the environment and or aesthetics in the vicinity of a project may be eligible for enhancement funding. For example, a construction project may present an opportunity to improve the condition of an adjacent stream bed to improve water quality, construct a vital link for a community bikeway system and develop a landscaped green area to enhance the downtown environment.

Activities that are not explicitly on the list may qualify if they are an integral part of a larger qualifying activity. For example, if the rehabilitation of a historic railroad station required the construction of new drainage facilities, the entire project could be considered for TE funding.

RESPONSE:

1. Provision of facilities for pedestrian and bicycles.

The proposed project will enhance and encourage pedestrian and bicycle transportation through preserving and improving an important off road trail link across the Mississippi River for pedestrians and bicycles. The bridge links the Cedar Riverside Neighborhood on the West Bank and the University of Minnesota on the East Bank, providing convenient and direct access to the University for thousands of students as well as regional residents and visitors. Bridge improvements will also ensure safe and convenient access to parks, employers, and recreational destinations near the project area.

6. Historic preservation.

In 1994, a historic evaluation determined that Bridge No. 9 is recommended eligible for nomination to the National Register of Historic Places. The proposed project will preserve and enhance the bridge as a historic asset to its users and the community. Improvement and preservation of Bridge No. 9 will ensure the continued presence and function of this historic and cultural resource for future generations.

8. Preservation of abandoned railway corridors converted to use for pedestrian and bicycle trails.

In 1999, Bridge No. 9 was rehabilitated and converted from a railroad bridge to an off road pedestrian and bicycle trail bridge. The proposed project will preserve and enhance the off road trail system and bridge that is located within an abandoned railway corridor.

2. The funded activities must be accessible to the general public or targeted to a broad segment of the general public, and must be ADA compliant.

RESPONSE:

The proposed project resulting from these funded activities will be accessible to the general public and is targeted to a broad segment of the general public, including pedestrians and bicyclists. The proposed improvements will be compliant with ADA guidelines where applicable.

3. Projects must relate to surface transportation.

Project Linkage (from federal guidance)

To comply with Federal guidelines for eligibility there are two basic considerations:

- Is the proposed action one of the listed activities in the TE definition in SAFETEA-LU?
- How does the proposed action relate to surface transportation?

The applicant must provide a clear statement describing this linkage.

The definition of TE activities includes the phrase, "transportation enhancement activities means, with respect to any project or the area to be served by the project, any of the following activities, if such activity relates to surface transportation:..."

The nature of a proposed TE project's relationship to surface transportation should be discussed in the project proposal that you submit. For example, where runoff from an existing highway contaminates an adjacent water resource and a transportation enhancement activity is proposed to mitigate the pollution caused by the runoff a clear highway or transportation relationship exists. Another example might involve the acquisition of a scenic easement. The acquisition would be in connection with the preservation of a scenic vista related to travel along a specific route.

Where a TE activity is for acquisition for scenic preservation purposes, and proposes to contribute to the visual experience of the traveler, but is a substantial distance away with respect to a highway or transportation project, the TE activity must be determined to make a substantial contribution to the scenic viewshed.

Given the nature of the list of eligible activities, it is not necessary that each TE activity be associated with a specific surface transportation project to be eligible for funding. Examples which illustrate this include: the rehabilitation of a historic train structure, the provision of a bike or pedestrian path, or the establishment of a transportation museum.

Proximity to a highway or transportation facility alone is not sufficient to establish a relationship to surface transportation. Additional discussion, beyond proximity, is needed in the TE project proposal to establish the relationship to transportation. For example, an historic barn that happened to be adjacent to a particular highway facility would not automatically be considered eligible for TE funds simply because of its location; visibility to the traveler in a way that substantially enhances the traveling experience could qualify. Specific documentation of the enhanced experience is required; conversely, a historic structure, such as the barn in the above example, could not be disqualified from consideration because it was not adjacent to a particular Federal-aid facility, as long as some other relationship to surface transportation could be established.

It is not necessary to have a TE activity function as an active transportation facility, either past or current, to qualify as an eligible TE activity. For example, a scenic or historic site may have a relationship to transportation but not function as a transportation facility.

Once a relationship to surface transportation is established, TE activities can be implemented in a number of ways. For example, they can be developed as parts of larger joint development projects, or as stand-alone projects.

RESPONSE:

The proposed project activities are listed in the TE definition in SAFETEA-LU as they provide and preserve facilities for pedestrians and bicycles, preserve historic transportation facilities, and preserve abandoned railway corridors that have been converted for use as pedestrian and bicycle trails. The proposed project relates to surface transportation as it is designed to serve the transportation needs of multi-modal transportation users, including pedestrians and bicyclists. The proposed project will extend the usable life of Bridge No. 9, thereby improving safety and efficiency of travel for pedestrians and bicyclists. The proposed project offers a cost-effective alternative to inaction, which would ultimately require a costly full replacement of the bridge.

4. The project must be included in, be part of, or relate to a problem, need or direction discussed in: 1) a local or county comprehensive plan found to be consistent with Metropolitan Council plans; 2) a locally approved capital improvement program; 3) an officially adopted corridor study reflected in the local plan; or 4) the official plan or program of the applicant agency. The applicant must reference the appropriate comprehensive plan, CIP, corridor study document, or other plan or program and provide copies of the applicable pages. Because all communities in the seven-county Twin Cities region are currently in the process of updating their local comprehensive plans, applications in the 2009 Solicitation may be for projects included in the most recent local comprehensive plan that was found to be consistent with Metropolitan Council plans. It also must not conflict with the goals and policies in these adopted regional plans: the 2030 Transportation Policy Plan, the 2030 Regional Framework, and the 2030 Regional Parks Policy Plan. Trail projects that claim to be part of the regional trail network as defined in the 2030 Regional Parks Policy Plan must be identified in a Metropolitan Council-approved trail master plan.

RESPONSE:

The proposed project is consistent with all existing local plans and is related to a specific need identified in the Minneapolis 2010-2014 Capital Plan (see Attachment C), approved by the Minneapolis City Council.

In addition, the proposed project is consistent with goals and policies outlined in the city's recent update to its comprehensive plan, submitted to the Metropolitan Council for formal review in October 2008. Policy 2.6 of the Minneapolis Plan for Sustainable Growth, page 8, states that the city is committed to maintaining "street infrastructure in good condition to extend the life" of the facility. The proposed project supports this policy by maintaining an important facility in order to extend its useful life. Policy 8.1, page 4, and Policy 8.5, page 9, relate to the need for historic preservation of "resources which serve as reminders of the city's architecture, history, and culture" and "materials typically found in public spaces," respectively. The proposed concrete repairs to this historic structure are consistent with these policies.

Furthermore, the proposed project does not conflict with, but rather is supportive of adopted regional plans, including the 2030 Transportation Policy Plan. Strategy 2a of the 2030 Transportation Policy Plan, page 7, states that "the first priority for transportation investments...is the preservation, operation, and maintenance of existing systems and facilities." The proposed project fully supports this strategy. In addition, Policy 18, page 19, states that municipalities should "develop and maintain efficient, safe, and appealing pedestrian and bicycle transportation systems." Improvements to Bridge No. 9 will ensure the safety, efficiency, and convenience of bicycle and pedestrian travel in the project area.

5. Typically a transportation project involves mitigation, work in addition to immediate construction activities, that is negotiated with permitting agencies and local governments as a condition of obtaining permit approval. Activities that are normally part of the mitigation of a transportation project are not eligible.

NOT ELIGIBLE - Work that is required as a condition of obtaining a permit or concurrence for a different transportation project is **not eligible** for enhancement funding. For example, a city may require a highway expansion project to include streetscape enhancements in order to gain municipal consent. In that case, streetscape work performed to satisfy the municipal consent requirement is not eligible for Transportation Enhancement funding. Federal permitting and authorizing agencies may include the U.S. Forest Service, U. S. Corps of Engineers, and others. State permitting agencies may include the Minnesota Department of Natural Resources, the Minnesota Pollution Control Agency, and the Minnesota State Historic Preservation Office. Regional agencies may include watershed districts and metropolitan planning organizations. Local agencies may include counties and cities.

RESPONSE:

The proposed project is a standalone construction project and is not part of a mitigation effort related to another transportation project.

6. The applicant must assure it will operate and maintain the property and facility of the project for the useful life of the improvement, and not change the use of any right-of-way acquired without prior approval from the Minnesota Department of Transportation and the Federal Highway Administration.

The FHWA requires that states agree to operate and maintain facilities constructed with federal transportation funds for the useful life of the improvement, and not change the use of any right-of-way acquired without prior approval from the FHWA. TAB has determined that this requirement will be applied to the project applicant. FHWA considers most physical constructions and total reconstructions to have a useful design life of 10 years or more, depending on the nature of the project. Bridge constructions and total reconstructions are considered to have useful lives of 50 years.

The useful life of the project will be defined in the inter-agency maintenance agreement that must be prepared and signed prior to the project letting.

RESPONSE:

The City of Minneapolis will operate and maintain the property and facilities of the project for the useful life of the improvement. The City of Minneapolis agrees to not change the use of any right-of-way acquired without prior approval from Hennepin County, Mn/DOT, and FHWA.

7. Projects must have an estimated total cost of at least \$125,000. There are significant federal project processing requirements that come with federal funds. These requirements translate into expenditures of time and money on the parts of both the agency proposing/developing the project and the state agency administering the federal funds for the project. Project applicants can "bundle" projects together to meet this minimum. (Example: bundled projects could consist of signing and lighting a number of bike trails in several counties.) Communities may want to consider using joint powers agreements for implementing bundled projects.

RESPONSE:

The estimated total cost of the project is \$6,875,000, which exceeds the \$125,000 minimum.

8. TAB will not award more than \$1,000,000 in TE funds to a specific project. Other federal funds may be combined with TE funds.

RESPONSE:

The total amount requested is \$1,000,000, which does not exceed the maximum award.

9. Projects must have an assured local (nonfederal funds) match of at least 20% of the estimated total cost of the proposed project. At the time of application, the applicant must assure the local match will be available when the project is authorized in the requested program year. If the applicant expects any other agency to provide part of the local match, the applicant must include a letter or resolution from the other agency agreeing to financially participate. TAB will not award additional points for providing a match in excess of 20%.

The local match can be provided in the form of cash up front "hard dollars" or a "soft match". A "soft match" may include donated labor or construction materials if adequate documentation of its equivalent dollar value and availability can be provided. Donated labor must have expertise and experience in the type of labor required for the project and valued at rates consistent with rates ordinarily paid for similar work. Some type of time sheet must support donated labor. Donated materials, e.g., railroad ties, asphalt pavement, or wiring necessary to run a street car, must meet all standards and specifications. Caution in using a "soft match" should be taken to ensure the donated materials or labor during actual construction does not fall below the 20% non-federal match required to be able to receive 100% of the federal funds. Applicants wishing to use a soft match should first contact John Lindemer at Mn/DOT at 651/366-3764 to determine its value and eligibility.

RESPONSE:

The City of Minneapolis will provide the local match in hard dollars collected with sale of local bonds.

10. Proposed designs for bikeways and for combined bike/pedestrian facilities must meet MN/DOT State Aid standards. Exceptions to the State Aid standards may be granted during final design if warranted based on social, economic or environmental alternatives, **not** through this solicitation process. Failure to meet the standards or justify exemptions will result in the loss of federal funds.

RESPONSE:

Where appropriate, the proposed project will meet Mn/DOT State Aid Standards and guidelines. It will also adhere to the Mn/DOT Bicycle Transportation Planning and Design Guidelines.

11. Projects must be coordinated with all affected communities and other levels and units of government. Coordination is defined as written communication from the applicant to all affected communities informing them of the project. The applicant must provide a copy of the written communication as proof of coordination.

RESPONSE:

The project has been discussed within the City of Minneapolis Public Works, Minneapolis City Council. Copies of correspondence and indicated project awareness are provided in Attachment E.

TE PROJECTS - PRIORITIZING CRITERIA

Instead of the past practice of having general prioritizing criteria to which all projects must respond, the prioritizing criteria are now split into category and general/integrative criteria, as outlined on the following pages. Projects will be scored through the category and general/integrative criteria as follows:

- a) **Category Criteria.** All applications must be submitted in one of three categories: Scenic and Environmental; Bicycle and Pedestrian; and Historical and Archaeological. Applicants must submit their project under the proper category as outlined below. However, projects that incorporate more than one of the eligible TE activities will receive priority under the third category criterion, Relationship Between Categories. If prospective applicants are uncertain which category most appropriately includes their project, they should contact Council staff.

The 12 Qualifying Activities (as listed and described in Qualifying Criterion #1 on previous pages) fall under those 3 categories as follows:

1. Scenic and Environmental:

- QA #3, Acquisition of scenic easements and scenic or historic sites;
- QA #4, Scenic or historic highway programs;
- QA #9, Inventory, control and removal of outdoor advertising; and
- QA #11, Environmental mitigation to address water pollution due to highway runoff or reduce vehicle-caused wildlife mortality while maintaining habitat connectivity.

2. Bicycle and Pedestrian Connections:

- **QA #1, Provision of facilities for pedestrians and bicyclists;**
- QA #2, Provision of safety and educational activities for pedestrians and bicyclists; and
- **QA #8, Preservation of abandoned railway corridors (including the conversion and use thereof for pedestrian and bicycle trails).**

3. Historic and Archaeological:

- **QA #6, Historic preservation (with relationship to transportation, see Qualifying Criterion #2);**
- QA #7, Rehabilitation and operation of historic transportation buildings, structures, or facilities (including historic railroad facilities and canals);
- QA #10, Archaeological planning and research (with relationship to transportation, see Qualifying Criterion #2); and
- QA #12, Establishment of transportation museums.

4. Streetscape/Pedestrian Enhancements:

- QA #5, Landscaping and other scenic beautification;
- **QA #1, Provision of facilities for pedestrians and bicyclists.**

- b) **Final Ranking.** The Category Criteria scores will be added to the Maturity of Project Concept criterion score to give final project scores. Projects will be ranked against other applications in their category to develop four ranked lists of TE projects, which will be evaluated all together by a multidisciplinary team of scorers, who will develop a single list of recommended projects. The TAB may or may not choose to fund projects from each category.

Transportation Enhancements Category Criteria (800 points)

Each qualified project will be scored under five common category criteria within its TE project group: urgency; impact; relationship between TE categories; and relationship to intermodal/multimodal transportation; and implementation of the Development Framework. This will allow projects to be scored under these criteria relatively equally across the different categories while addressing the particular attributes of the project type. An explanation of each of the four common category criteria and reasons for their inclusion follows:

1. **Urgency/Significance.** This criterion measures how critical or time-sensitive the problem is that is being addressed by a regionally significant project. Examples might include seizing a timely opportunity to preserve a scarce or endangered resource or addressing a critical need.
2. **Impact.** This criterion quantifies the benefit from the project, without specifically relating it to how the larger public will benefit (that calculation will be made in part 2. of the general/integrative criteria).
3. **Relationship between Categories.** This criterion is being presented under the assumption that the region recognizes that there is a value in having projects that provide more than one of the eligible TE activities. Examples might include the reconstruction of a bicycle/pedestrian trail leading to a historic transportation structure.
4. **Relationship to Intermodal/Multimodal Transportation System.** This criterion measures how the proposed project clearly and credibly relates to the surface transportation system. Surface transportation is defined to include all modes of travel with the exception of aviation and military transportation. Federal TE guidance states that proximity to a transportation facility alone is not sufficient to establish a relationship.
5. **Development Framework.** This criterion measures how the proposed project relates to the goals for land use development, resource protection and transportation described in the 2030 Regional Development Framework and 2030 Transportation Policy Plan.

▪ **Bicycle and Pedestrian Pathway Group (Qualifying Activities 1, 2, and 8)**

1. **Urgency/Significance (250 points).** Discuss how the project proposes or addresses each of the following:
 - Takes advantage of a time-sensitive opportunity, e.g., a willing landowner, cost savings, affiliation with another project, competing development opportunities

RESPONSE:

The proposed project addresses the ongoing deterioration of the concrete areas at the ends of the pier caps immediately adjacent to the fascia bearings of the deck truss main spans and the steel plate girder approach spans; the ongoing corrosion of the steel plate girders adjacent to the deck longitudinal joint of the approach spans; and the ongoing deterioration and corrosion of the bearings for the main span deck truss spans and the steel plate girder approach spans of Bridge No. 9 (see Figures 8 to 10 in Attachment A).

The implications of these deteriorated sections are severe. If the structure is allowed to continue to deteriorate, especially the concrete deterioration of the pier caps, the bridge will have to be closed when the concrete pier cap deterioration extends under the fascia bearings resulting in a dangerous condition where the pier caps cannot support the bridge loads and the potential for the bridge superstructure to become unstable. The cost to rehabilitate the bridge in this condition will be significantly higher since the bridge superstructure would have to be stabilized and jacked up in order to repair the concrete pier caps.

- Addresses a significant opportunity, un-met need or problem as relates to the development of an integrated bicycle or pedestrian transportation network; or providing a safe/enjoyable bicycle or pedestrian route.

RESPONSE:

Improvements are needed on Bridge No. 9 in order to extend its useful life. If the structure is allowed to deteriorate, the improvements and rehabilitation will no longer be cost-effective. Total in-kind structure replacement of this bridge would be extremely costly, and should be avoided. As such, this project seizes a timely opportunity to protect this historic structure in a cost-effective manner with minimal disruption to existing pedestrian and bicycle traffic.

2. **Impact (250 points).** Discuss how the project addresses each element below (respond as appropriate to A. or B., not both):

A. Bike/Ped Infrastructure (QA #1, and QA #8):

- Fills gaps, overcomes barriers, connects system segments and/or otherwise seizes on a significant opportunity in pedestrian/bicycle network. **The applicant should provide a map showing the location of the project within the context of an existing and planned bicycle or pedestrian network.** If the project is removing a barrier, the applicant should demonstrate the magnitude of the barrier (number of lanes, average daily traffic, posted speed, etc.) and how the proposed project will improve travel across that barrier.

RESPONSE:

Bridge No. 9 currently provides a City of Minneapolis off road trail link between the Cedar Riverside Neighborhood on the West Bank and the University of Minnesota on the East Bank with a facility crossing the Mississippi River. This project will ensure continued use of the City of Minneapolis off road trail. Refer to Attachment B – Figures 1, 2, 3A, and 3B for local bicycle and off road trail maps and Attachment D for project layout exhibits.

- Project provides a high-demand facility or program. Relative levels of demand will be determined using population density and connections to significant travel attractors. Metropolitan Council staff will determine population density using 2000 residential population within one mile of the project. The applicant should also list below significant destinations that are near the facility or that the facility provides close connections to. Destinations can be recreation areas such as parks, beaches, rivers, lakes, etc; or commercial or mixed-use districts, major employment areas or other major cultural destinations.

RESPONSE:

Bridge No. 9 currently provides a critical City of Minneapolis off road trail crossing of the Mississippi River linking the Cedar Riverside Neighborhood on the West Bank and the University of Minnesota on the East Bank. This project will ensure continued use of the City of Minneapolis off road trail in the future.

- Addresses safety concerns. The applicant should describe how the project addresses an identified safety problem.

RESPONSE:

Bridge No. 9 currently provides a safe City of Minneapolis off road trail crossing of the Mississippi River. This project will ensure that the current safe conditions will extend to the future.

- For Applications for Qualifying Activity #8 only: Who owns the railway corridor property and will there be an agreement to ensure the preservation and protection of the corridor?

RESPONSE:

In 1986, Bridge No. 9 (including the rail corridor right-of-way) was sold to the City of Minneapolis by Burlington Northern Railroad Company (now Burlington Northern Santa Fe Railroad Company).

B. Bike/Ped Programs (QA #2):

- Significantly improves safety/behavior of bicyclists and pedestrians

RESPONSE: N/A

- Increases market share/use of bicycling and walking

RESPONSE: N/A

- Fills gaps in existing programs. Describe the target audience in this program and how they would benefit from these activities or programs.

RESPONSE: N/A

- Provides more than a local benefit. An example of such a program is a bicycle/pedestrian safety program conducted in several school districts.

RESPONSE: N/A

3. Relationship between Categories (100 points). Projects will score higher if they provide multiple benefits toward the purpose of the Transportation Enhancements program. Applicants should review the respective category criteria to determine the extent to which the project relates to the other two categories:

- What is the relationship to the Scenic and Environmental group? For example, how does the bike/ped project provide a natural resource enhancement?

RESPONSE:

The proposed bridge improvements are strongly related to the environmental group as they will ensure the continued provision of an important non-motorized transportation facility and include appropriate environmental mitigation measures where necessary.

The bridge improvements will provide and enhance pedestrian and bicycle connections to the natural areas near the project area, including the nearby Currie Park, Father Hennepin Bluffs Park, and the recreational trails of the Mississippi River.

When the bridge improvements are planned, all efforts will be taken to ensure that there are no or minimal impacts to the natural environment. If there are impacts, proper mitigation techniques will be applied. Best management practices with regard to construction will be employed to reduce impacts from runoff and other issues that occur during concrete improvements and during painting of the steel superstructure.

- What is the relationship to the Historic and Archaeological group? For example, how does the bike/ped project take advantage of or enhance historic and cultural resources or provide orientation/interpretation to users?

RESPONSE:

In 1994, a historic evaluation determined that Bridge No. 9 is recommended eligible for nomination to the National Register of Historic Places. The proposed project will preserve and enhance the bridge as a historic asset to its users and the community. Improvement and preservation of Bridge No. 9 will ensure the continued presence and function of this historic and cultural resource for future generations.

4. **Relationship to Intermodal/Multimodal Transportation System (100 points).** Discuss how the project will function as a component and/or enhancement of the transportation system:
- How will the bicycle or pedestrian facility benefit the experience of users of the transportation system?

RESPONSE:

The proposed bridge improvements will ensure that Bridge No. 9 remains functional and safe well into the future, serving pedestrians and bicyclists.

Pedestrians and bicyclists will benefit through continued access to a crucial river crossing between the Cedar Riverside Neighborhood on the West Bank and the University of Minnesota on the East Bank. If Bridge No. 9 is allowed to continue to deteriorate resulting in closure, these non-motorized system users would be forced to travel nearly one half mile up river and three quarters of a mile down river to cross the Mississippi River.

- How will the project benefit multiple modes of transportation? An example of a project that would do this would be a bicycle facility that connects to a transit center or a mixed-use pedestrian-oriented district, or a pedestrian project that is a component of a transit-oriented development.

RESPONSE:

By ensuring that Bridge No. 9 continues to function safely, the proposed rehabilitation project will benefit users of multiple modes, including pedestrians, bicyclists, transit users, and motorists.

Pedestrian and bicyclists will benefit from the preservation of this crucial Mississippi River crossing. Without the pedestrian and bicycle facilities on Bridge No. 9, these non-motorized system users would be forced to travel nearly one half mile up river or three quarters of a mile down river to cross the Mississippi River. Given it's proximity to the East Bank of the University of Minnesota and the densely populated areas of student housing in the Cedar Riverside Neighborhood, the bridge is a primary route linking students and employees to the University.

The proposed project will benefit users of many local transit services operating around Bridge No. 9. Preservation and rehabilitation of the bridge will ensure that pedestrians and bicyclists can continue to use Bridge No. 9 in a protected right-of-way to access transit routes on either side of the river, in order to reach the greater regional transit network.

The project will benefit motorists in the vicinity of Bridge No. 9 by ensuring continued use of the City of Minneapolis off road trail as a non-motorized facility for pedestrians and bicyclists, thus resulting in less congestion of vehicles on the local streets in the area.

- How does the facility serve trips that could otherwise be made by motor vehicles?

RESPONSE:

The City of Minneapolis off road trail facility over the Mississippi River provides a convenient and attractive alternate to local residents and University of Minnesota students and employees to travel between the Cedar Riverside Neighborhood on the West Bank to the University of Minnesota on the East Bank.

5. **Development Framework (100 points)**

- If the project is a trail project, does it help to connect to or complete the Metropolitan Council's Regional Trail network? How so? If the project is on part of the Regional Trail system, it must be identified in a Metropolitan Council-approved master plan.

RESPONSE:

Bridge No. 9 currently provides a critical City of Minneapolis off road trail crossing of the Mississippi River linking the Cedar Riverside Neighborhood on the West Bank and the University of Minnesota on the East Bank. This project will ensure continued use of the City of Minneapolis off road trail in the future.

This off road trail is part of the City of Minneapolis bike trail system that is connected to the Metropolitan Council's Regional Trail network.

- Briefly describe how the project implements the Bicycle and Pedestrian Plan in the 2030 Transportation Policy Plan (2009).

RESPONSE:

The proposed improvements will continue to facilitate pedestrian and bicycle movements on and around Bridge No. 9, and in doing so, will support several goals and policies maintained in the Metropolitan Council's 2030 Transportation Policy Plan. The proposed project will fulfill the Council's priority policy of maintaining and preserving investment in existing infrastructure. The proposed bridge improvements will ensure safe and convenient pedestrian and bicycle travel and access to frequent transit service on either end of the bridge span. The proposed improvements have the potential to yield significant and measurable improvements in maintaining an important and historic resource while providing a crucial river crossing link for multimodal transportation system users.

General Criteria (200 points)

Maturity of Project Concept.

200 points

Projects selected through this solicitation will be programmed for construction in 2013 or 2014. That is a fairly long time but it takes several years to complete preliminary engineering, environmental studies and acquire right-of-way. The region must manage the federal funds in each year of the TIP. Projects that are not implemented in their original program year create problems. Proposed projects that have already completed some of the work is a plus. A schedule is important to know what kind of work might be needed. Large projects that need right-of-way require more work than others that do not.

- 0-200 points** Applications involving construction must complete the project implementation schedule found in Appendix K. A detailed schedule of events is expected for all phases of the project. Applications involving non-construction projects must include a detailed discussion of the timeframes involved for initiating and completing each phase of planned activities. Points under this criterion are assigned based on how many steps have been taken toward implementation of the project. These steps reflect a federally funded project development path.

Refer to Attachment H for the Project Implementation Schedule found in Appendix K.

TOTAL: 1000 POINTS

ATTACHMENT A – PROJECT LOCATION MAPS

FIGURE 1: PROJECT LOCATION MAP (AERIAL)

FIGURE 2: PROJECT LOCATION MAP (USGS)

FIGURES 3 TO 10: PROJECT PHOTOS (BRIDGE)

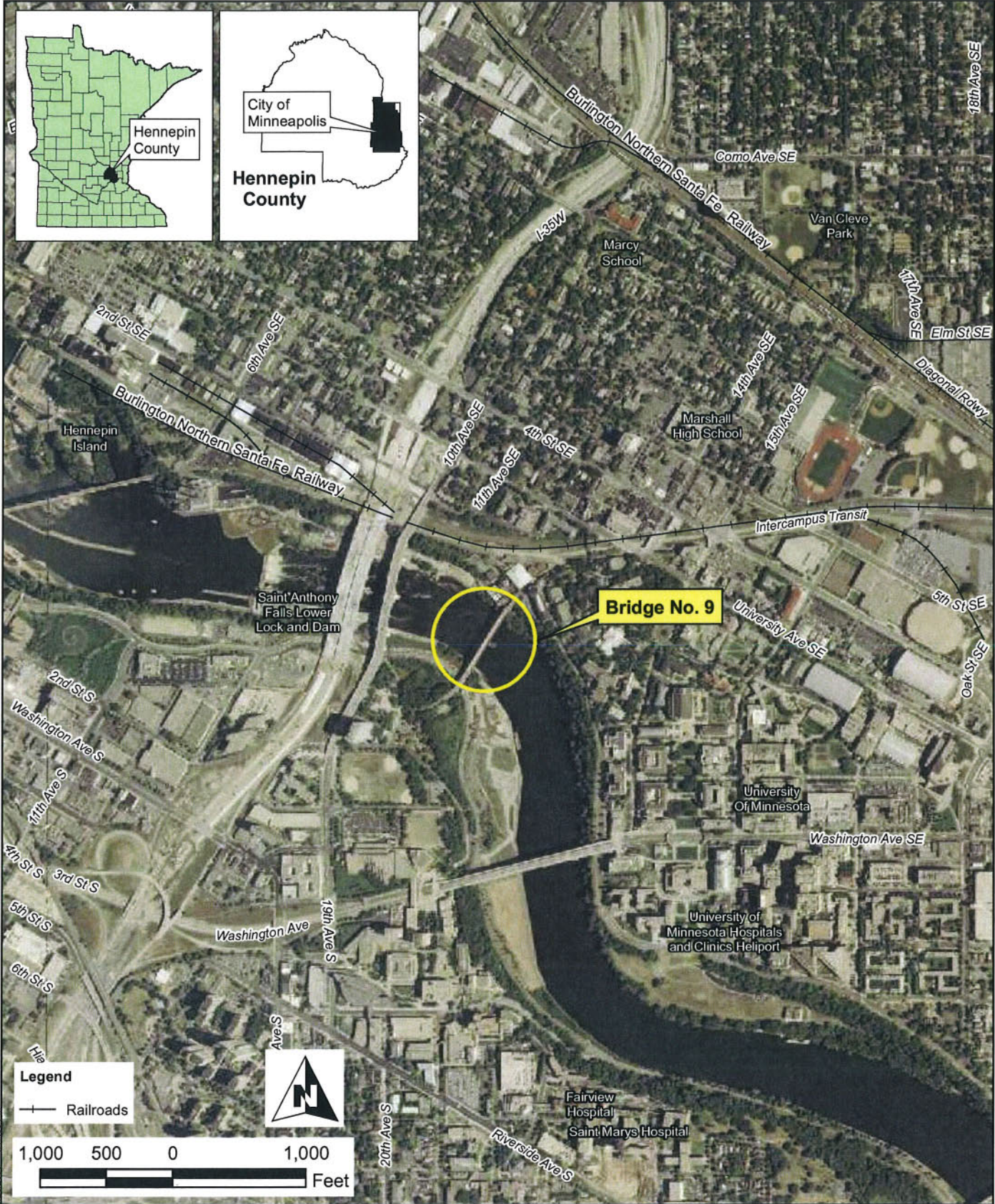

Legend
 — Railroads

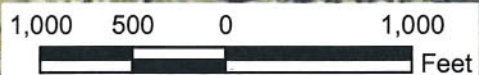

Map Document: S:\KOW\Minpls108529\GIS\Maps\Fig01_OverviewMap.mxd
 5/28/2009 4:17:59 PM

	3535 VADNAIS CENTER DR. ST. PAUL, MN 55110 PHONE: (651) 490-2000 FAX: (651) 490-2150 WATTS: 800-325-2055 www.sehinc.com	Project: MNPLS108529 Print Date: 05/28/2009 Map by: SH Projection: UTM, Zone 15, NAD 83, m Source: USGS 7.5 Min. Topo, MnDOT, and SEH Inc.	<p align="center">Site Location</p> <p align="center">BRIDGE NO. 9 PEDESTRIAN BRIDGE OVER MISSISSIPPI RIVER Minneapolis, Minnesota</p>	<p align="center">Attachment A</p> <p align="center">Figure 1</p>
	<p><small>This map is neither a legally recorded map nor a survey map and is not intended to be used as one. This map is a compilation of records, information, and data gathered from various sources listed on this map and is to be used for reference purposes only. SEH does not warrant that the Geographic Information System (GIS) Data used to prepare are error free, and SEH does not represent that the GIS Data can be used for navigational, tracking, or any other purpose requiring exacting measurement of distance or direction or precision in the depiction of geographic features. The user of this map acknowledges that SEH shall not be liable for any damages which arise out of the user's access or use of data provided.</small></p>			

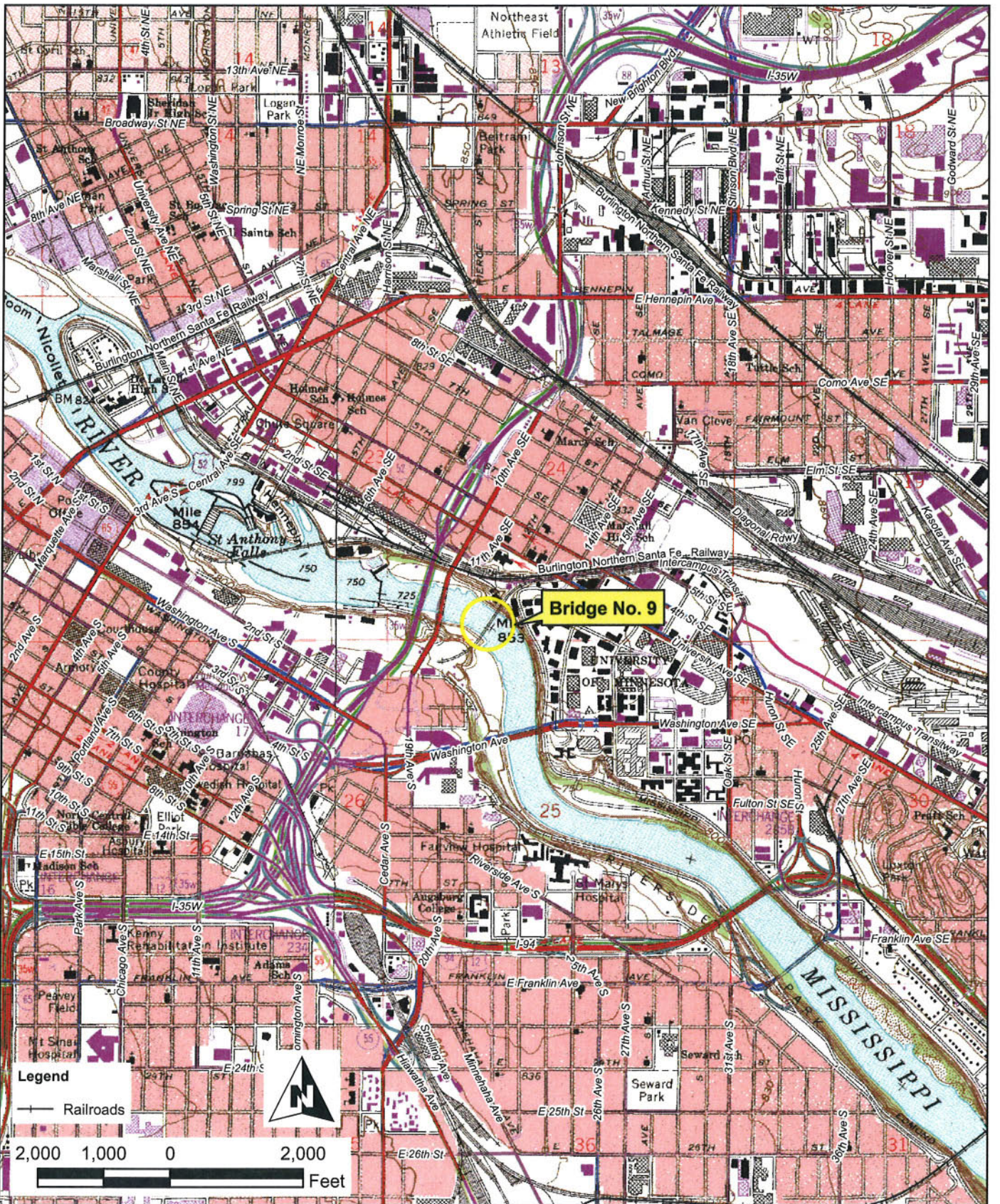

Map Document: S:\KOMM\Maplist\108529\GIS\Map\Fig02_QuadOverviewMap.mxd
 5/28/2009 4:15:06 PM

	<p>3535 VADNAIS CENTER DR. ST. PAUL, MN 55110 PHONE: (651) 490-2000 FAX: (651) 490-2150 WATTS: 800-325-2055 www.sehinc.com</p>	<p>Project: MNPLS108529 Print Date: 05/28/2009 Map by: SH Projection: UTM, Zone 15, NAD 83, m Source: USGS 7.5 Min. Topo, MNDOT, and SEH Inc.</p>	<p>Project Location Map BRIDGE NO. 9 PEDESTRIAN BRIDGE OVER MISSISSIPPI RIVER Minneapolis, Minnesota</p>	<p>Attachment A Figure 2</p>
---	---	--	--	---

This map is neither a legally recorded map nor a survey map and is not intended to be used as one. This map is a compilation of records, information, and data gathered from various sources listed on this map and is to be used for reference purposes only. SEH does not warrant that the Geographic Information System (GIS) Data used to prepare are error free, and SEH does not represent that the GIS Data can be used for navigational, tracking, or any other purpose requiring exacting measurement of distance or direction or precision in the depiction of geographic features. The user of this map acknowledges that SEH shall not be liable for any damages which arise out of the user's access or use of data provided.

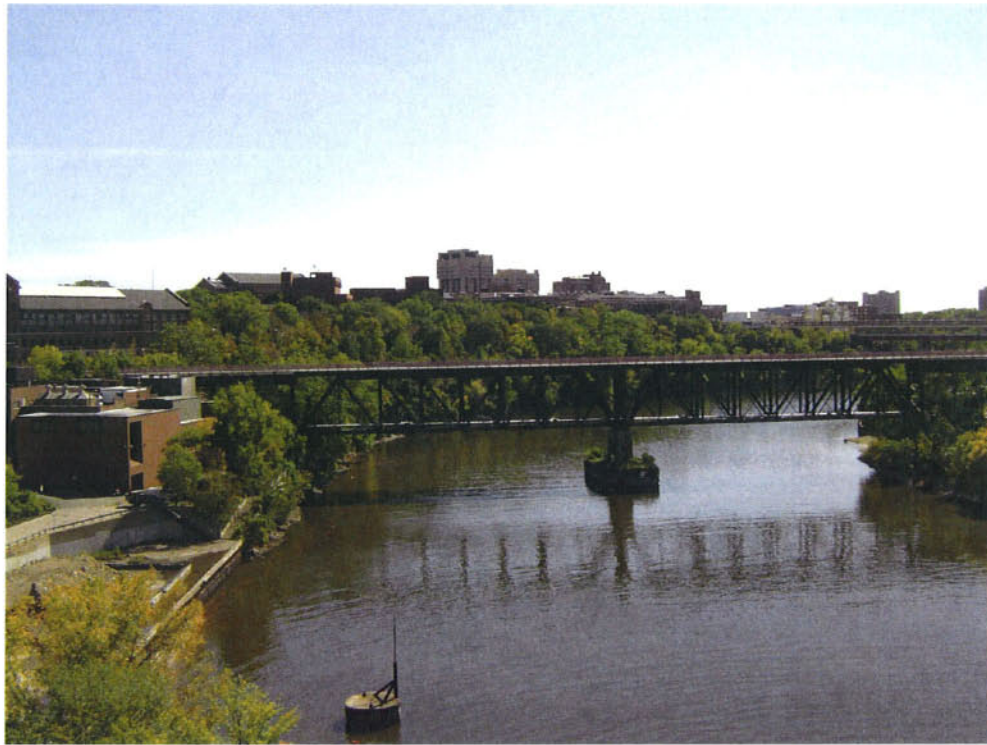

Looking South Towards Bridge No. 9



Looking North Towards Bridge No. 9

BRIDGE NO. 9 OVER
MISSISSIPPI RIVER

ATTACHMENT A FIGURE 3
EXISTING CONDITIONS
PHOTOGRAPHS



Looking East at West Abutment of Bridge No. 9



Looking West at East Abutment of Bridge No. 9

BRIDGE NO. 9 OVER
MISSISSIPPI RIVER

ATTACHMENT A FIGURE 4
EXISTING CONDITIONS
PHOTOGRAPHS



Looking West Towards West Abutment of Bridge No. 9



Looking East on Bridge No. 9

BRIDGE NO. 9 OVER
MISSISSIPPI RIVER

ATTACHMENT A FIGURE 5
EXISTING CONDITIONS
PHOTOGRAPHS



Looking East Towards East Abutment of Bridge No. 9



Original
Nameplate



New
Nameplate



Historical
Marker
At East Abutment



Looking Towards West Approach Spans of Bridge No. 9



West Approach Spans of Bridge No. 9

BRIDGE NO. 9 OVER
MISSISSIPPI RIVER

ATTACHMENT A FIGURE 7
EXISTING CONDITIONS
PHOTOGRAPHS



Looking Towards River Pier Fender of Bridge No. 9



Truss Bearing of Bridge No. 9

BRIDGE NO. 9 OVER
MISSISSIPPI RIVER

ATTACHMENT A FIGURE 8
EXISTING CONDITIONS
PHOTOGRAPHS



Looking Towards West Approach Span Bearings at Pier 7 of Bridge No. 9



Looking Towards West Approach Bearings at Pier 6 of Bridge No. 9

BRIDGE NO. 9 OVER
MISSISSIPPI RIVER

ATTACHMENT A FIGURE 9
EXISTING CONDITIONS
PHOTOGRAPHS



Looking Towards South Deck Edge in End Span of Bridge No. 9



Center Deck Joint at West Approach Span of Bridge No. 9

ATTACHMENT B – SYSTEM MAPS

FIGURE 1: MINNEAPOLIS BIKEWAYS MASTER PLAN - 2001

FIGURE 2: MINNEAPOLIS BIKEWAYS MASTER PLAN – 2008 DRAFT

FIGURE 3A: MINNEAPOLIS MULTI-MODAL MAP

FIGURE 3B: MINNEAPOLIS MULTI-MODAL MAP (DOWNTOWN)

CITY OF MINNEAPOLIS BIKEWAYS MASTER PLAN

CITY COUNCIL,
MAYOR, &
MPRB APPROVED
DECEMBER 2001

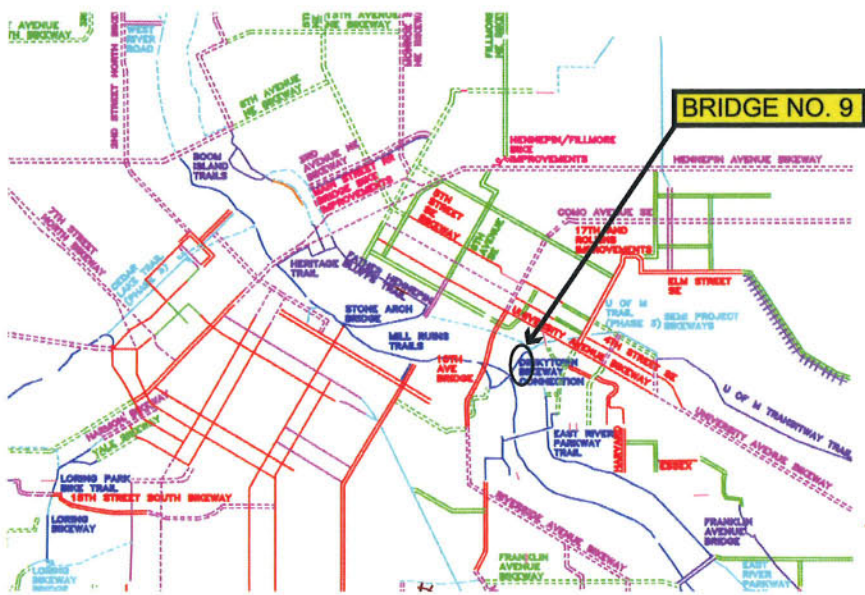

- EXISTING OFF-STREET PAVED BIKE TRAIL (BIKES AND PEDESTRIANS SEPARATED - BIKEWAY 4 FEET OR MORE PER DIRECTION)
- EXISTING OFF-STREET PAVED BIKE TRAIL (SHARED USE TRAIL - TRAIL 8 FEET OR MORE IN WIDTH)
- ||||||| EXISTING OFF-STREET PAVED BIKE TRAIL (SEPARATED TRAIL - BIKEWAY WIDTH LESS THAN 4 FEET PER DIRECTION)
- ||||||| EXISTING OFF-STREET PAVED BIKE TRAIL (SHARED USE TRAIL - TRAIL WIDTH LESS THAN 8 FEET WIDE)
- PLANNED BIKE TRAIL (PROGRAMMED, CONSTRUCTION STARTING BY 2006)
- PROPOSED BIKE TRAIL (CANDIDATE OFF-STREET FACILITY)
- EXISTING ON-STREET STRIPED BIKE LANE (4 FEET OR MORE IN WIDTH)
- ||||||| EXISTING ON-STREET STRIPED BIKE LANE (LESS THAN 4 FEET IN WIDTH)
- ON-STREET PLANNED BIKE LANE (PROGRAMMED, CONSTRUCTION STARTING BY 2006 - 4 FEET OR MORE IN WIDTH)
- ON-STREET PROPOSED BIKE LANE (CANDIDATE ON-STREET FACILITY - 4 FEET OR MORE IN WIDTH)
- EXISTING SIGNED ON-STREET BIKE ROUTE (PROGRAMMED ON-STREET BIKE ROUTE)
- PROPOSED SIGNED ON-STREET BIKE ROUTE
- EXISTING PEDESTRIAN BRIDGE
- PROPOSED PEDESTRIAN/BIKE BRIDGE
- UNPAVED BIKE TRAIL (4 FEET OR MORE IN WIDTH SURFACE TO INCLUDE GRAVEL OR Limestone)
- ||||||| EXISTING CONCRETE SIDEWALK TRAIL



3535 VADNAIS CENTER DR.
ST. PAUL, MN 55110
PHONE: (651) 490-2000
FAX: (651) 490-2150
WATTS: 800-325-2055
www.sehinc.com

Project: MNPLS108529
Print Date: 05/28/2009
Map by: SEH
Projection: UTM, Zone 15, NAD 83, m
Source: USGS 7.5 Min. Topo, MnDOT, and SEH Inc.

Site Location
BIKEWAYS MASTER PLAN
Minneapolis, Minnesota

Attachment B
Figure 1

This map is neither a legally recorded map nor a survey map and is not intended to be used as one. This map is a compilation of records, information, and data gathered from various sources listed on this map and is to be used for reference purposes only. SEH does not warrant that the Geographic Information System (GIS) Data used to prepare are error free, and SEH does not represent that the GIS Data can be used for navigational, tracking, or any other purpose requiring exacting measurement of distance or direction or precision in the depiction of geographic features. The user of this map acknowledges that SEH shall not be liable for any damages which arise out of the user's access or use of data provided.

CITY OF MINNEAPOLIS 2008 DRAFT BIKEWAYS MASTER PLAN

- TRAIL
- BIKE LANES
- SIGNED BIKE ROUTES
- BICYCLE/PEDESTRIAN BRIDGE
- EXPERIMENTAL BIKEWAY
- SHOULDER ACCOMMODATIONS
- BICYCLE BOULEVARD

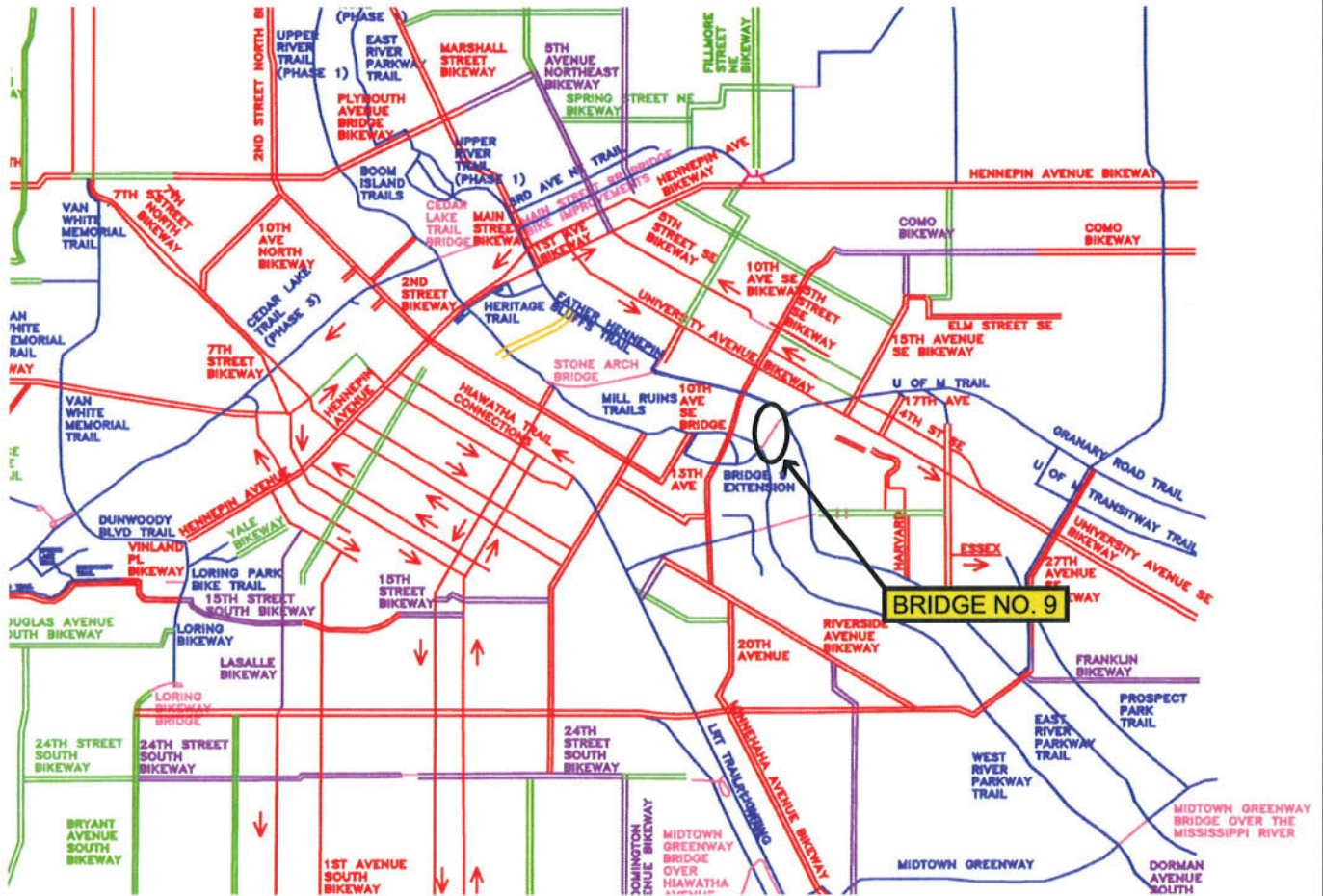

	3535 VADNAIS CENTER DR. ST. PAUL, MN 55110 PHONE: (651) 490-2000 FAX: (651) 490-2150 WATTS: 800-325-2055 www.sehinc.com	Project: MNPLS108529 Print Date: 05/28/2009 Map by: SEH Projection: UTM, Zone 15, NAD 83, m Source: USGS 7.5 Min. Topo, MnDOT, and SEH Inc.	<h3 style="margin: 0;">Site Location</h3> <h2 style="margin: 0;">2008 DRAFT BIKEWAYS MASTER PLAN</h2> <p style="margin: 0;">Minneapolis, Minnesota</p>	Attachment B Figure 2
	This map is neither a legally recorded map nor a survey map and is not intended to be used as one. This map is a compilation of records, information, and data gathered from various sources listed on this map and is to be used for reference purposes only. SEH does not warrant that the Geographic Information System (GIS) Data used to prepare are error free, and SEH does not represent that the GIS Data can be used for navigational, tracking, or any other purpose requiring exacting measurement of distance or direction or precision in the depiction of geographic features. The user of this map acknowledges that SEH shall not be liable for any damages which arise out of the user's access or use of data provided.			

Legend

- Existing Off-road Bicycle Trail
- Pending Construction
- Existing On-road Bicycle Trail
- Pending Construction
- Interstate Highway 94
- State or U.S. Expressway 100 12
- State or U.S. Highway 55 52
- County Road 117 14
- Municipal Road
- Proposed Highway/County Road
- Hiawatha LRT Line and Station
- Northstar Commuter Rail (Nov. 2009)
- Great River Road
- Regional or County Park
- City Hall/County Library/County Service Center
- Major Park and Ride
- County Public Works
- Emergency Hospital
- Park Entrance

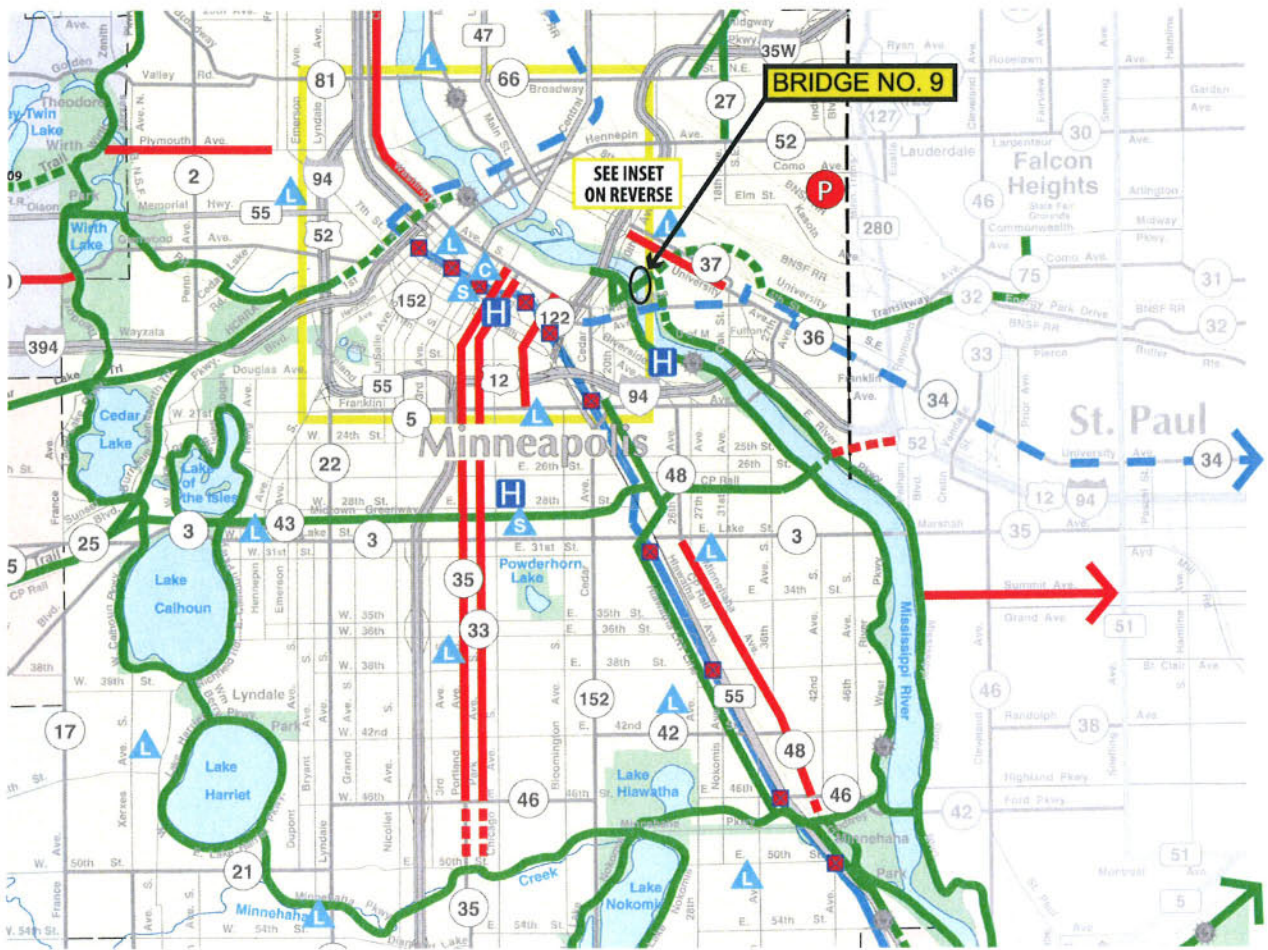

3535 VADNAIS CENTER DR.
ST. PAUL, MN 55110
PHONE: (651) 490-2000
FAX: (651) 490-2150
WATTS: 800-325-2055
www.sehinc.com

Project: MNPLS108529
Print Date: 05/28/2009
Map by: SEH
Projection: UTM, Zone 15, NAD 83, m
Source: USGS 7.5 Min. Topo,
MnDOT, and SEH Inc.

Site Location
CITY OF MINNEAPOLIS MULTI-MODAL MAP
Minneapolis, Minnesota

Attachment B
Figure 3A

This map is neither a legally recorded map nor a survey map and is not intended to be used as one. This map is a compilation of records, information, and data gathered from various sources listed on this map and is to be used for reference purposes only. SEH does not warrant that the Geographic Information System (GIS) Data used to prepare are error free, and SEH does not represent that the GIS Data can be used for navigational, tracking, or any other purpose requiring exacting measurement of distance or direction or precision in the depiction of geographic features. The user of this map acknowledges that SEH shall not be liable for any damages which arise out of the user's access or use of data provided.

Downtown Minneapolis

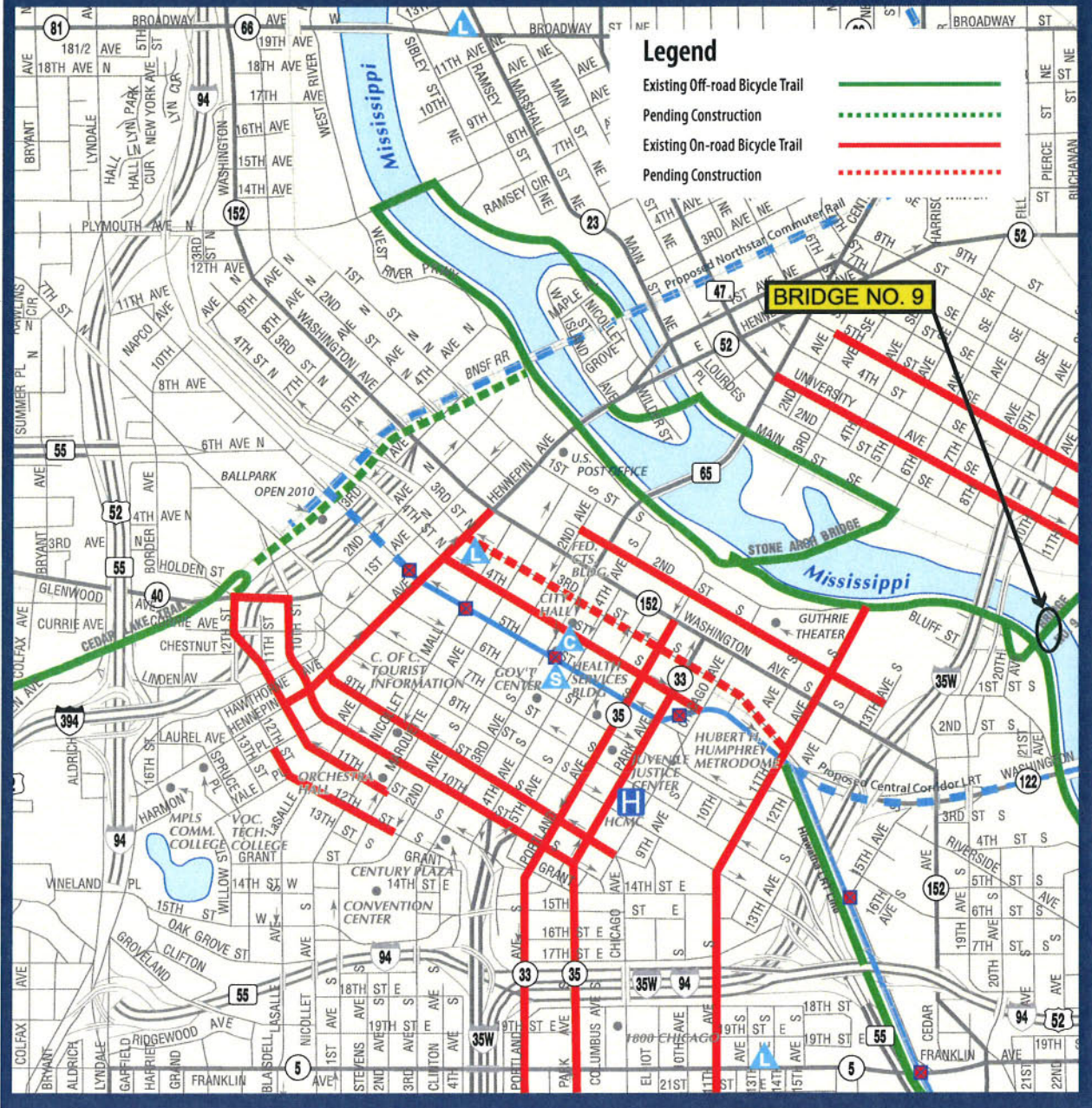

Legend

- Existing Off-road Bicycle Trail ———
- Pending Construction - - - - -
- Existing On-road Bicycle Trail ———
- Pending Construction - - - - -

BRIDGE NO. 9



3535 VADNAIS CENTER DR
ST. PAUL, MN 55110
PHONE: (651) 490-2000
FAX: (651) 490-2150
WATTS: 800-325-2055
www.sehinc.com

Project: MNPLS108529
Print Date: 05/28/2009
Map by: SEH
Projection: UTM, Zone 15, NAD 83, m
Source: USGS 7.5 Min. Topo,
MnDOT, and SEH Inc.

Site Location
CITY OF MINNEAPOLIS MULTI-MODAL MAP
(DOWNTOWN)
Minneapolis, Minnesota

Attachment B
Figure 3B

This map is neither a legally recorded map nor a survey map and is not intended to be used as one. This map is a compilation of records, information, and data gathered from various sources listed on this map and is to be used for reference purposes only. SEH does not warrant that the Geographic Information System (GIS) Data used to prepare are error free, and SEH does not represent that the GIS Data can be used for navigational, tracking, or any other purpose requiring exacting measurement of distance or direction or precision in the depiction of geographic features. The user of this map acknowledges that SEH shall not be liable for any damages which arise out of the user's access or use of data provided.

ATTACHMENT C – MINNEAPOLIS CIP APPROVED PROJECT LIST

Capital Improvement Projects

Council Approved 2009 Projects - 2010 - 2014 Capital Plan Submitted to CLIC

Subject to Change

Map Date: June 11, 2009



- Map Key:
- City Council
 - City Department
 - City Engineer
 - City Planning
 - City Public Works
 - City Police
 - City Fire
 - City Public Safety
 - City Parks & Recreation
 - City Health & Human Services
 - City Housing
 - City Economic Development
 - City Community Development
 - City Cultural Resources
 - City Information Technology
 - City Office of the Mayor
 - City Office of the City Clerk
 - City Office of the City Attorney
 - City Office of the City Auditor
 - City Office of the City Treasurer
 - City Office of the City Manager

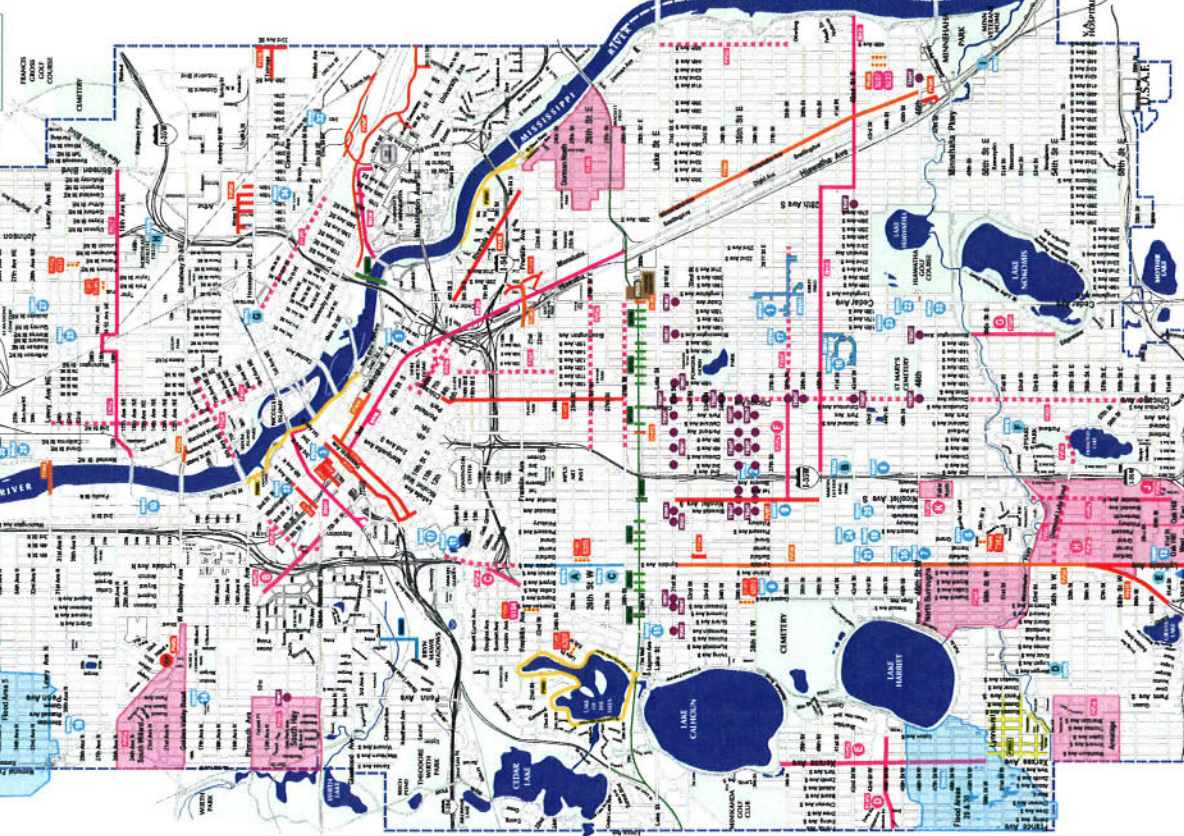

ID	PROJECT NAME	2009	2010	2011	2012	2013	2014
2009-0001	Center City Job Plan #1						
2009-0002	Center City Job Plan #2						
2009-0003	Center City Job Plan #3						
2009-0004	Center City Job Plan #4						
2009-0005	Center City Job Plan #5						
2009-0006	Center City Job Plan #6						
2009-0007	Center City Job Plan #7						
2009-0008	Center City Job Plan #8						
2009-0009	Center City Job Plan #9						
2009-0010	Center City Job Plan #10						
2009-0011	Center City Job Plan #11						
2009-0012	Center City Job Plan #12						
2009-0013	Center City Job Plan #13						
2009-0014	Center City Job Plan #14						
2009-0015	Center City Job Plan #15						
2009-0016	Center City Job Plan #16						
2009-0017	Center City Job Plan #17						
2009-0018	Center City Job Plan #18						
2009-0019	Center City Job Plan #19						
2009-0020	Center City Job Plan #20						
2009-0021	Center City Job Plan #21						
2009-0022	Center City Job Plan #22						
2009-0023	Center City Job Plan #23						
2009-0024	Center City Job Plan #24						
2009-0025	Center City Job Plan #25						
2009-0026	Center City Job Plan #26						
2009-0027	Center City Job Plan #27						
2009-0028	Center City Job Plan #28						
2009-0029	Center City Job Plan #29						
2009-0030	Center City Job Plan #30						
2009-0031	Center City Job Plan #31						
2009-0032	Center City Job Plan #32						
2009-0033	Center City Job Plan #33						
2009-0034	Center City Job Plan #34						
2009-0035	Center City Job Plan #35						
2009-0036	Center City Job Plan #36						
2009-0037	Center City Job Plan #37						
2009-0038	Center City Job Plan #38						
2009-0039	Center City Job Plan #39						
2009-0040	Center City Job Plan #40						
2009-0041	Center City Job Plan #41						
2009-0042	Center City Job Plan #42						
2009-0043	Center City Job Plan #43						
2009-0044	Center City Job Plan #44						
2009-0045	Center City Job Plan #45						
2009-0046	Center City Job Plan #46						
2009-0047	Center City Job Plan #47						
2009-0048	Center City Job Plan #48						
2009-0049	Center City Job Plan #49						
2009-0050	Center City Job Plan #50						

2009-0001 Parkway Paving Program

2009-0001 Parkway Paving Program (Continued from 2008)

2009-0002 Parkway Paving Program (Continued from 2008)

2009-0003 Parkway Paving Program (Continued from 2008)

2009-0004 Parkway Paving Program (Continued from 2008)

2009-0005 Parkway Paving Program (Continued from 2008)

2009-0006 CSMA Paving Program

2009-0006 CSMA Paving Program (Continued from 2008)

2009-0007 CSMA Paving Program (Continued from 2008)

2009-0008 CSMA Paving Program (Continued from 2008)

2009-0009 CSMA Paving Program (Continued from 2008)

2009-0010 CSMA Paving Program (Continued from 2008)

2009-0011 Alley Renovation Program

2009-0011 Alley Renovation Program (Continued from 2008)

2009-0012 Alley Renovation Program (Continued from 2008)

2009-0013 Alley Renovation Program (Continued from 2008)

2009-0014 Alley Renovation Program (Continued from 2008)

2009-0015 Alley Renovation Program (Continued from 2008)

2009-0016 Street Renovation Program

2009-0016 Street Renovation Program (Continued from 2008)

2009-0017 Street Renovation Program (Continued from 2008)

2009-0018 Street Renovation Program (Continued from 2008)

2009-0019 Street Renovation Program (Continued from 2008)

2009-0020 Street Renovation Program (Continued from 2008)

2009-0021 Traffic

2009-0021 Traffic (Continued from 2008)

2009-0022 Traffic (Continued from 2008)

2009-0023 Traffic (Continued from 2008)

2009-0024 Traffic (Continued from 2008)

2009-0025 Traffic (Continued from 2008)

2009-0030 Storm Drain

2009-0030 Storm Drain (Continued from 2008)

2009-0031 Storm Drain (Continued from 2008)

2009-0032 Storm Drain (Continued from 2008)

2009-0033 Storm Drain (Continued from 2008)

2009-0034 Storm Drain (Continued from 2008)

2009-0036 Sanitary

2009-0036 Sanitary (Continued from 2008)

2009-0037 Sanitary (Continued from 2008)

2009-0038 Sanitary (Continued from 2008)

2009-0039 Sanitary (Continued from 2008)

2009-0040 Sanitary (Continued from 2008)

2009-0045 Water

2009-0045 Water (Continued from 2008)

2009-0046 Water (Continued from 2008)

2009-0047 Water (Continued from 2008)

2009-0048 Water (Continued from 2008)

2009-0049 Water (Continued from 2008)

ATTACHMENT D – PROJECT EXHIBITS

- FIGURE 1: GENERAL PLAN AND ELEVATION
- FIGURE 2: TYPICAL SECTION
- FIGURE 3: TYPICAL TRUSS SECTION
- FIGURE 4: MEMBER IDENTIFICATION
- FIGURE 5: WATERPROOFING LAYOUT PLAN
- FIGURE 6: WATERPROOFING DETAILS
- FIGURE 7: PIER DETAILS



LIST OF SHEETS	
NO.	DESCRIPTION
1	GENERAL PLAN AND ELEVATION
2	TYPICAL SECTIONS AND QUANTITIES
3	TRUSS AND GIRDER CONNECTIONS
4	TRUSS AND GIRDER CONNECTIONS
5	TRUSS AND GIRDER CONNECTIONS
6	WATERPROOFING LAYERS PLAN
7	WATERPROOFING DETAILS
8	PIER DETAILS

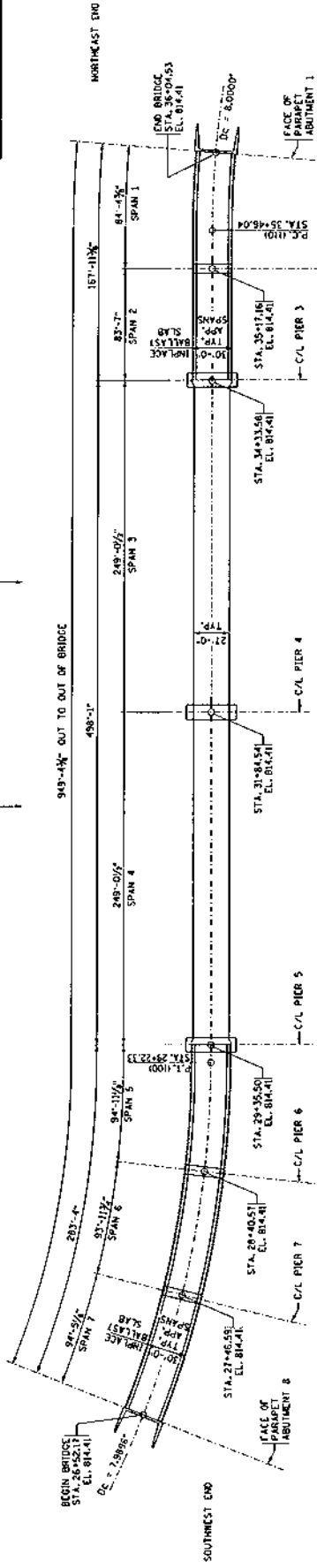

GENERAL PLAN

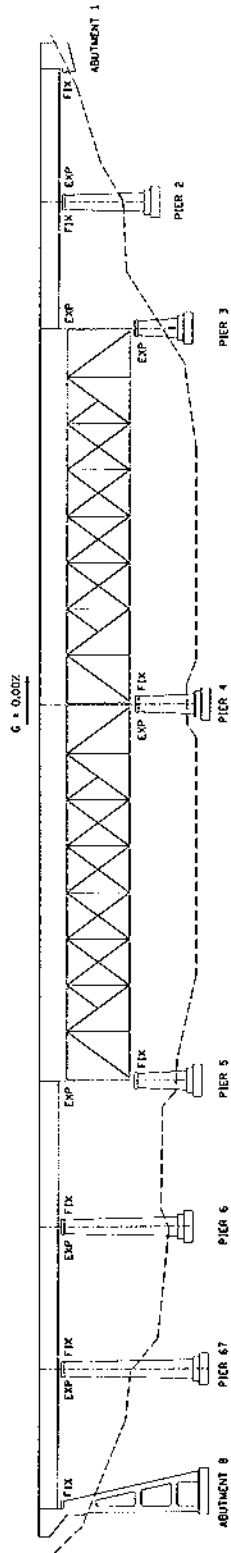

GENERAL ELEVATION

GENERAL PLAN AND ELEVATION

FIGURE NO. 1

BRIDGE NUMBER 94246 DINKY TOWN BIKEWAY CONNECTION OVER THE MISSISSIPPI RIVER AT THE UNIVERSITY OF MINNESOTA IN MINNEAPOLIS

SEH
3171/2009

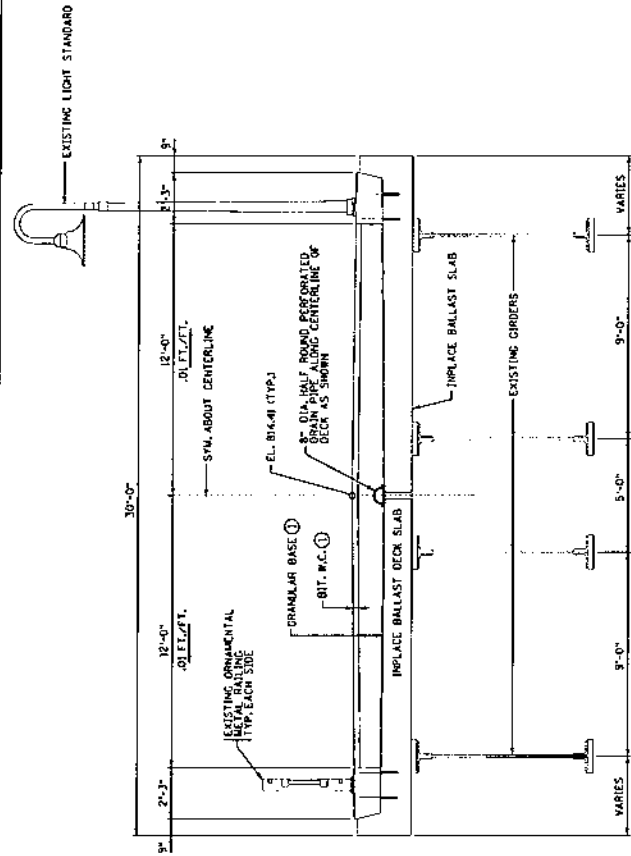

TYPICAL TRANSVERSE SECTION AT APPROACH SPANS
 IMPLACE BRIDGE 94246

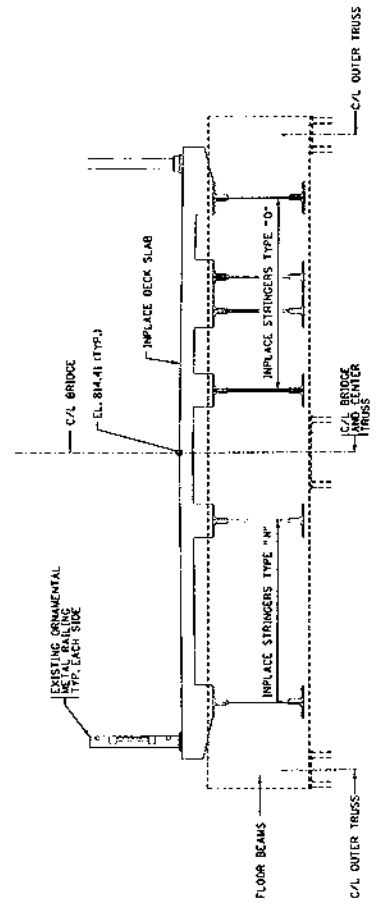

TYPICAL TRANSVERSE SECTION AT TRUSS SPANS

TYPICAL SECTION

FIGURE NO. 2

BRIDGE NUMBER 94246 DINKYTOWN BIKEWAY CONNECTION
 OVER THE MISSISSIPPI RIVER AT THE UNIVERSITY OF MINNESOTA IN MINNEAPOLIS
 TYPICAL SECTION &
 SUMMARY OF QUANTITIES

SEH
 315 UNIVERSITY CENTER DRIVE
 ST. PAUL, MN 55108
 PHONE 651/487-2000
 FAX 651/487-7422

10122126.RP

17127209

5170\WORK\11\190446-5-03\11-000R5\FRONT\17127209.TIF 9/24/03 11:27:09

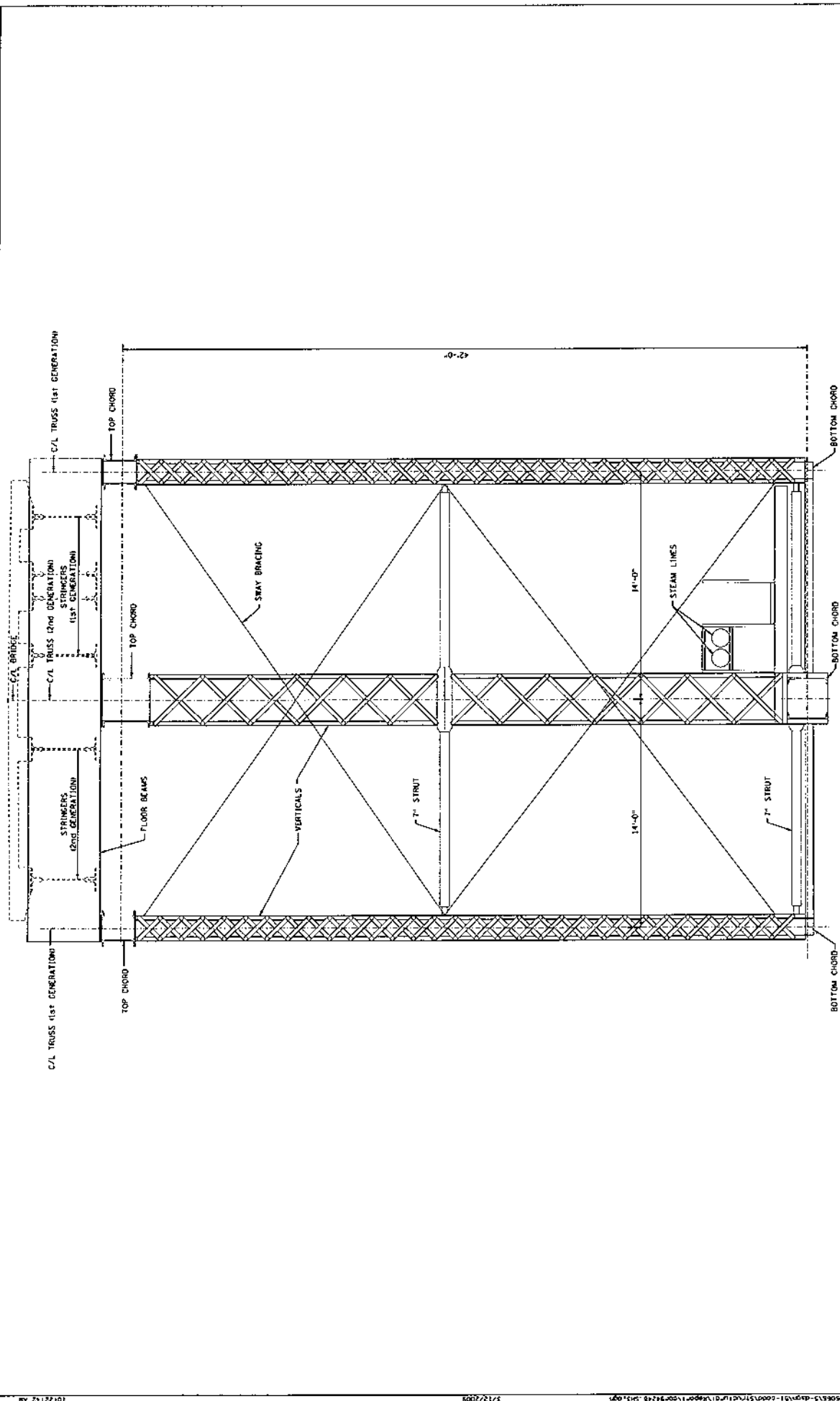

TYPICAL TRUSS SECTION
FIGURE NO. 3

TYPICAL TRANSVERSE SECTION AT TRUSS SPANS
BRIDGE NUMBER 94246 DINKYTOWN BIKEWAY CONNECTION
OVER THE MISSISSIPPI RIVER AT THE UNIVERSITY OF MINNESOTA IN MINNEAPOLIS

SEH
375 UNIVERSITY CENTER DRIVE
ST. PAUL, MN 55108
PHONE 651-455-2000
FAX 651-455-7972

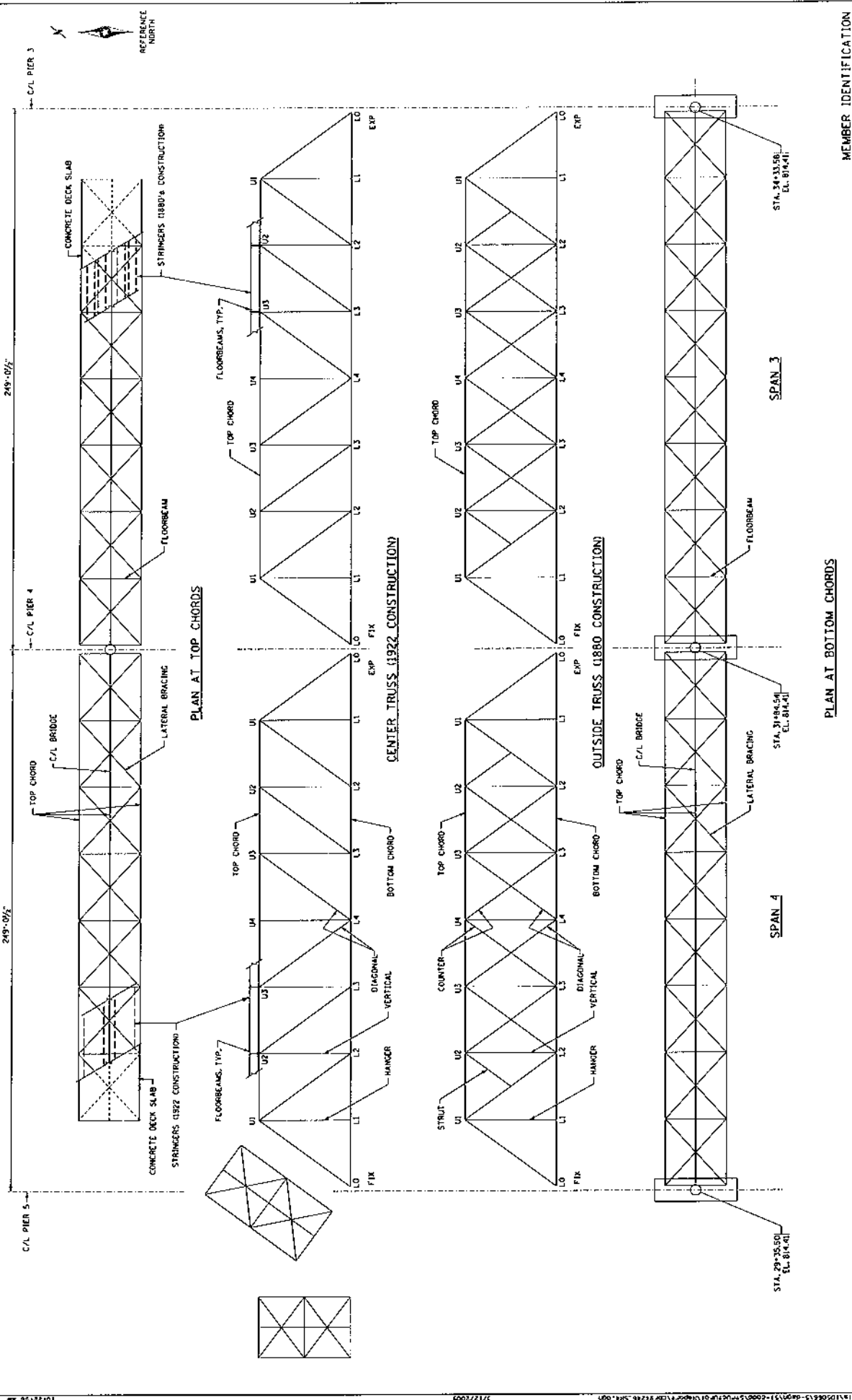

MEMBER IDENTIFICATION

FIGURE NO. 4

PLAN AT TOP CHORDS

PLAN AT BOTTOM CHORDS

BRIDGE NUMBER 94246 DINKYTOWN BIKEWAY CONNECTION
OVER THE MISSISSIPPI RIVER AT THE UNIVERSITY OF MINNESOTA IN MINNEAPOLIS

3125 VANDERBILT CENTER DRIVE
MINNEAPOLIS, MN 55405
TEL: 612-328-7000
FAX: 612-328-7000

SCHEDULE OF QUANTITIES FOR MEMBRANE WATERPROOFING SYSTEM		
ITEM	UNIT	TOTAL
STRUCTURAL STEEL (3308)	POUND	8979
MEMBRANE WATERPROOFING	SQ. FT.	12571
DRAINAGE SYSTEM	LUMP SUM	1

QUANTITIES FOR TIE MEMBERS AND WATERPROOFING SYSTEM PAID FOR BY THE LUMP SUM AND SHOWN IN ALL ITEMS SHOWN ON THIS SHEET UNLESS OTHERWISE NOTED.

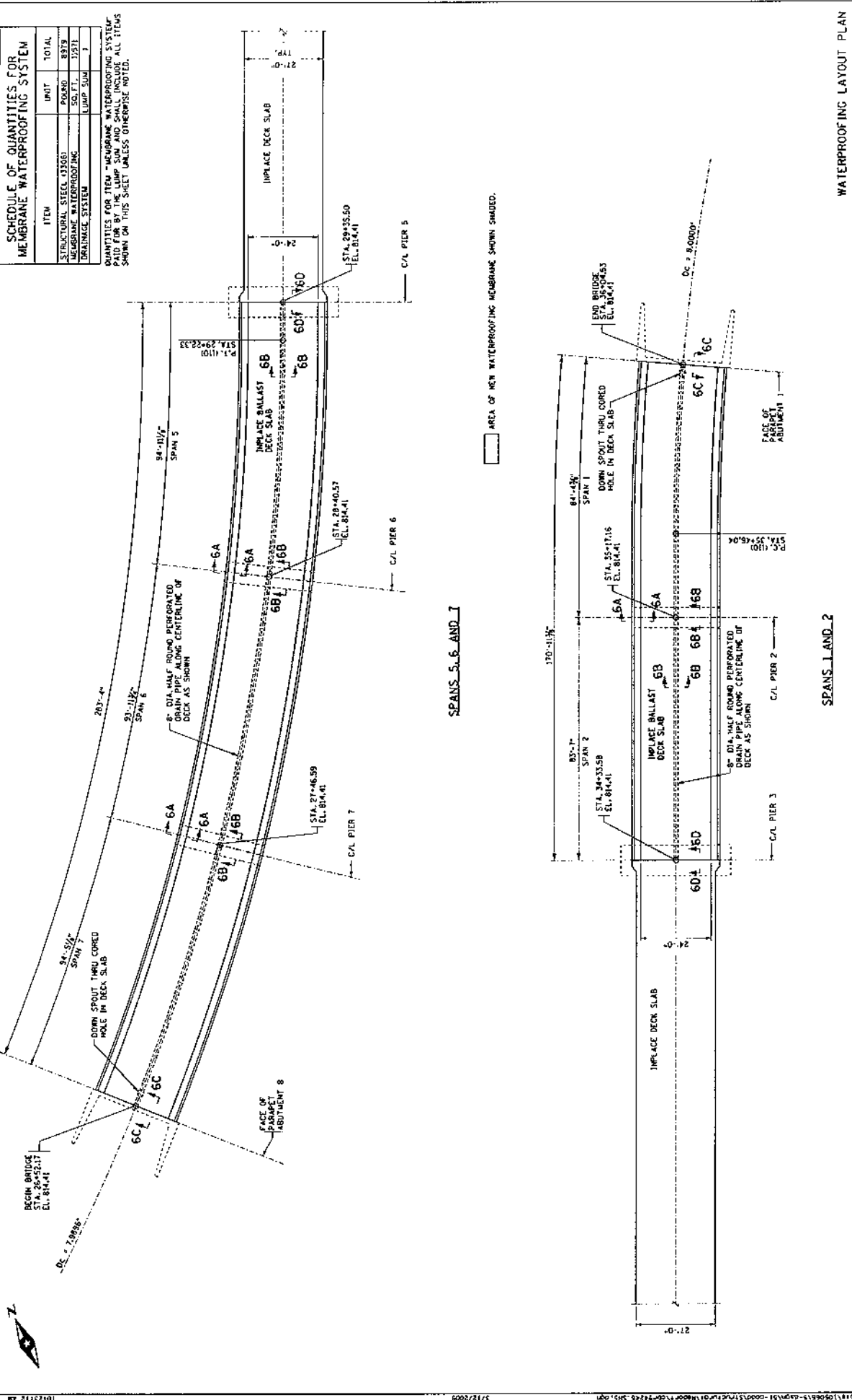

SPANS 5, 6 AND 7

SPANS 1 AND 2

WATERPROOFING LAYOUT PLAN

BRIDGE NUMBER 94246 DINKYTOWN BIKEWAY CONNECTION OVER THE MISSISSIPPI RIVER AT THE UNIVERSITY OF MINNESOTA IN MINNEAPOLIS

SEH
3110 University Avenue
St. Paul, MN 55102
Phone: 651-763-0000
Fax: 651-763-0000

FIGURE NO. 5

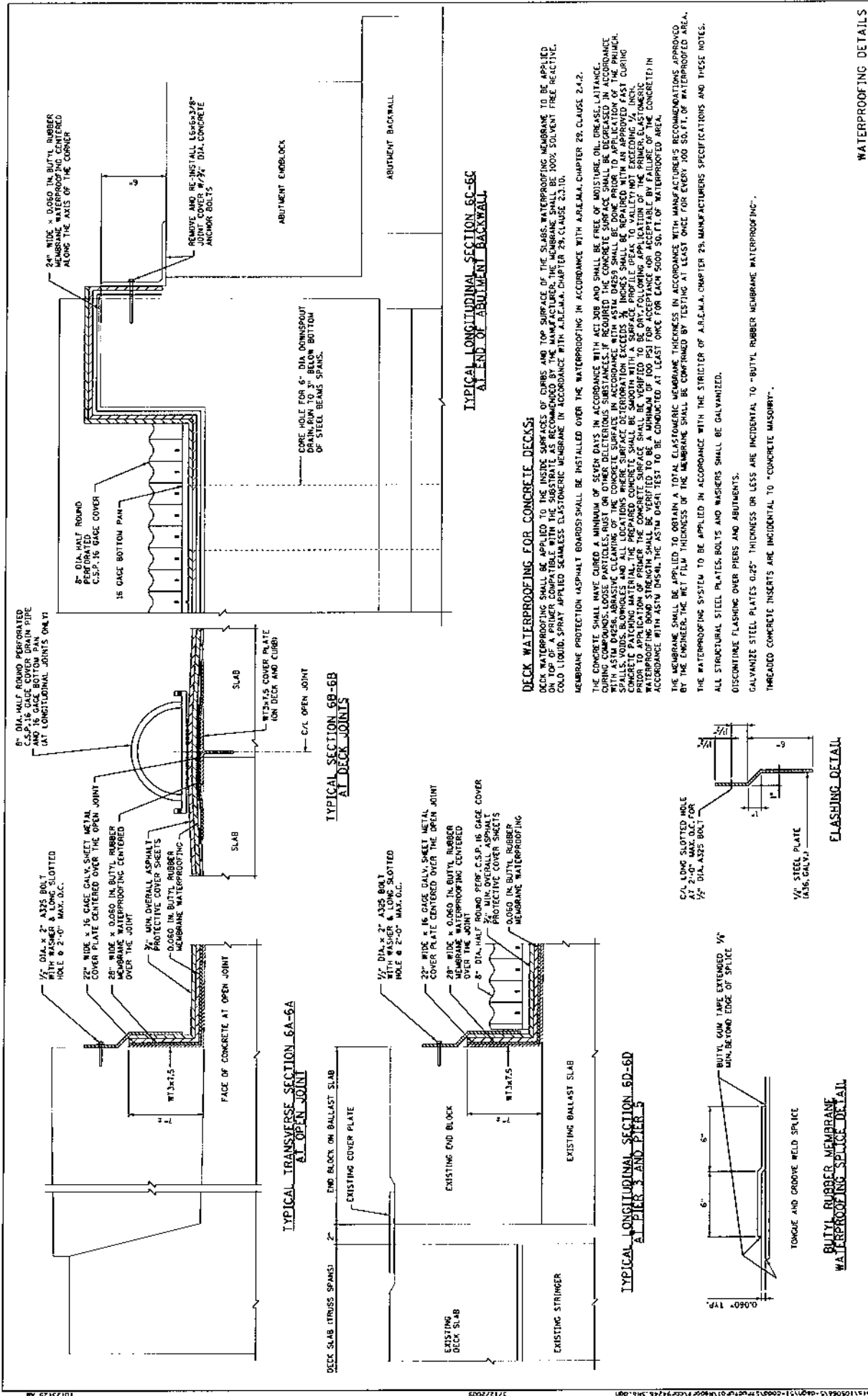

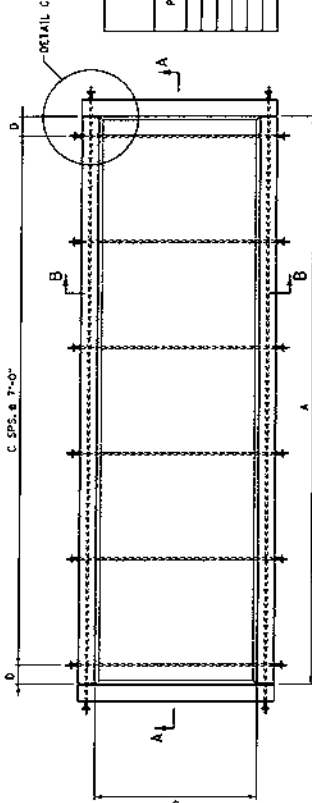

SCHEDULE OF QUANTITIES FOR POST-TENSIONING SYSTEM

ITEM	UNIT	PIER 2	PIER 3	PIER 4	PIER 5	PIER 6	PIER 7	TOTAL
STRUCTURAL STEEL 33260	POUND	13269	16579	16837	16579	13269	13269	90000
POST-TENSIONING DECS	LIN.FT.	186	246	249	246	186	186	1299
CURTAIN WALLS	YD	79	63	66	63	35	35	297
CONCRETE SURFACE REPAIR	LUMP SUM	76	74	16	14	46	60	406

PIER CAP DIMENSIONS

PIER	DIMENSIONS			
	A	B	C	D
2	30'-3"	7'-0"	4	1'-1/2"
3	37'-7"	10'-6"	5	1'-3/4"
4	37'-7"	11'-0"	5	1'-3/4"
5	37'-7"	10'-6"	5	1'-3/4"
6	30'-3"	7'-0"	4	1'-1/2"
7	30'-3"	7'-0"	4	1'-1/2"

QUANTITIES FOR ITEM "POST-TENSIONING SYSTEM" PAID FOR BY THE SYS. SYSTEM AND SHALL INCLUDE ALL ITEMS SHOWN ON THIS SHEET UNLESS OTHERWISE NOTED.

RODS SHALL COMPLY WITH M-7007 SPEC. 3313, TYPE 1.
 SHAPES, PLATES, FLAT BARS AND ANCHORAGES SHALL COMPLY WITH M-7007 SPEC. 3306.
 GALVANIZE BOLTS, NUTS, WASHERS AND RODS AS PER M-7007 SPEC. 3392.
 ALL OTHER MATERIALS SHALL COMPLY WITH M-7007 SPEC. 3309 AFTER FABRICATION.

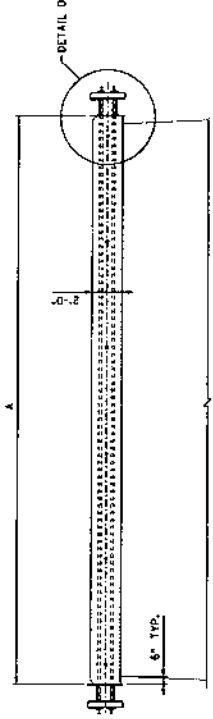
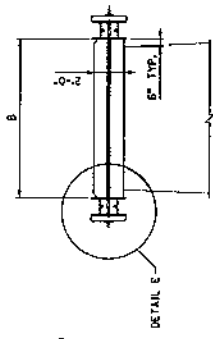

SECTION A-A

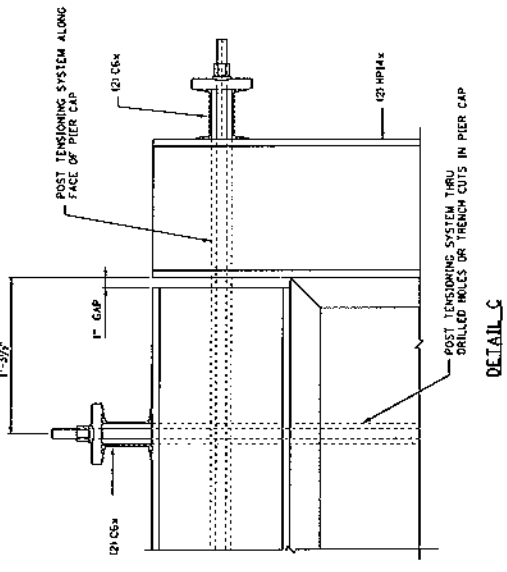

SECTION B-B

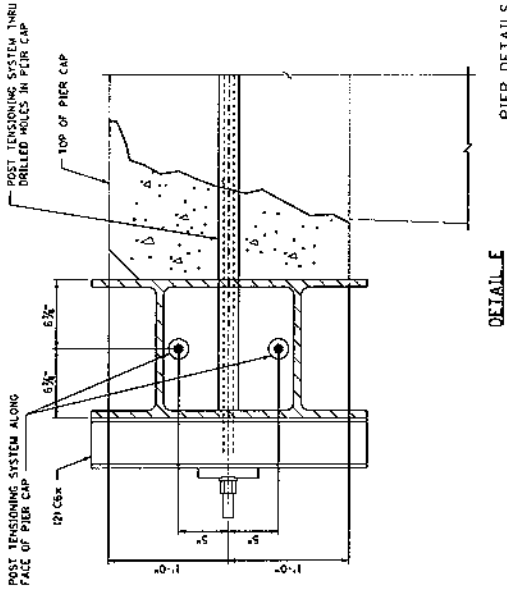
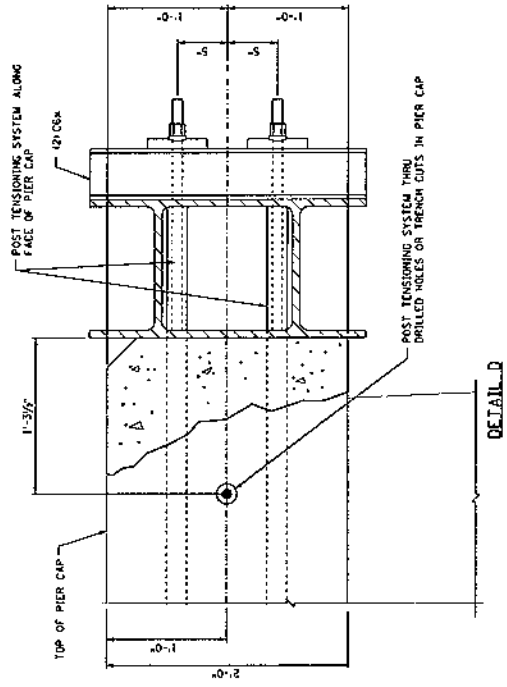

DETAIL C

DETAIL D

DETAIL E

PIER DETAILS

FIGURE NO. 7

BRIDGE NUMBER 94246 DINKYTOWN BIKEWAY CONNECTION
 OVER THE MISSISSIPPI RIVER AT THE UNIVERSITY OF MINNESOTA IN MINNEAPOLIS

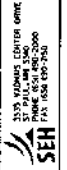

ATTACHMENT E – PROJECT SUPPORT CORRESPONDENCE

MAY 22, 2009

Discharge Elimination System/State Disposal System permit maintained by the Minneapolis Water Works. The agreement includes payment of a civil penalty in the amount of \$13,300, which will be paid from the Water Enterprise Fund (07400).

Adopted 5/22/2009.

T&PW & W&M/Budget - Your Committee recommends that the proper City officers be authorized to execute an agreement between the City of Minneapolis, Hennepin County, and the Minneapolis Park and Recreation Board, as set forth in Petn No 273500, for roadway improvements on and adjacent to Victory Memorial Parkway between Xerxes Ave N and Irving Ave N.

Adopted 5/22/2009.

T&PW & W&M/Budget - Your Committee recommends that the proper City officers be authorized to submit a series of applications for federal Safe, Accountable, Flexible, Efficient Transportation Equity Act: A Legacy for Users (SAFETEA-LU) New Freedom funds passed through the state.

Your Committee further recommends that local funds be committed to support the approved SAFETEA_LU projects, per federal requirements.

Adopted 5/22/2009.

T&PW & W&M/Budget - Your Committee recommends acceptance of the following bids submitted to the Public Works Department:

a) OP 7110, Accept low bid of HBM Services, Inc., for an estimated annual expenditure of \$90,000, to furnish and deliver janitorial services at the Public Service Center;

b) OP 7124, Accept low bid of Construction Results, for an estimated expenditure of \$254,790, to furnish and deliver areaway abandonment;

c) OP 7128, Accept low bid of Kone, inc., for an estimated expenditure of \$45,000, to furnish and deliver elevator and escalator maintenance; and

d) OP 7129, Accept low bid of Huis Bros. Trucking, Inc., d/b/a Avon AG-Lime for an estimated expenditure of \$2,225,000, to furnish and deliver all labor, equipment, and incidentals necessary to load, haul, and dispose of water treatment residuals for the Public Works Water Department.

Your Committee further recommends that the proper City officers be authorized and directed to execute a contract for said services, all in accordance with City specifications and contingent upon approval of the Civil Rights Department.

Adopted 5/22/2009.

The WAYS & MEANS/BUDGET Committee submitted the following reports:

W&M/Budget - Your Committee recommends passage of the accompanying resolution authorizing the settlement of legal matters, as recommended by the City Attorney.

Adopted 5/22/2009.

Resolution 2009R-236, authorizing settlement of *Michael Maile v. City of Minneapolis, et al.*; *Blia Xiong, Johnny Her and David Herv. City of Minneapolis*, was adopted 5/22/2009 by the City Council. A complete copy of this resolution is available for public inspection in the office of the City Clerk.

The following is the complete text of the unpublished summarized resolution.

RESOLUTION 2009R-236

By Ostrow

Authorizing legal settlements.

Resolved by The City Council of The City of Minneapolis:

That the City Attorney is authorized to proceed with the settlements of:

**ATTACHMENT F – MN/DOT STRUCTURE INVENTORY AND INSPECTION
REPORTS FOR BRIDGE #94246**

ATTACHMENT G – PRELIMINARY PROJECT COST ESTIMATE

**CONSTRUCTION COST ESTIMATE
BRIDGE NO. 9 OVER THE MISSISSIPPI RIVER**

Federal Aid Participating Items (STP)

Pier Repairs	\$ 412,000
Approach Spans Waterproofing and Clean/Repair Bearings	\$ 319,000
Abutment Repairs	\$ 25,000
Repair and Paint Steel Superstructure	\$4,413,500
Install "No Vehicles Allowed" Sign	<u>\$ 500</u>
Construction Total	\$5,170,000
Engineering/Administration 33%	\$1,705,000
Total Project Cost	\$6,875,000

Notes:

- Costs are indicated in 2009 dollars
- Cost based on preliminary concept.
Actual cost will be based upon final design.

ATTACHMENT H - APPENDIX K / PROJECT IMPLEMENTATION SCHEDULE

APPENDIX K

Project Implementation Schedule

Please check those that apply and fill in anticipated completion dates

1) **Project Scope**

- Stake Holders have been identified
- Meetings or contacts with Stake Holders have occurred

2) **Layout or Preliminary Plan**

- Identified Alternates
 - Selected Alternates
 - Layout or Preliminary Plan started
 - Layout or Preliminary Plan completed
 - Condition Study Report by Short Elliott Hendrickson, Inc. has been completed.
- Anticipated date or date of completion: 2013

3) **Environmental Documentation**

- EIS EA PM

Document Status

- Document not started
- Document in progress; environmental impacts identified
- Document submitted to State Aid for review (date submitted: _____)
- Document approved (need copy of signed cover sheet)

Anticipated date or date of completion/approval: 2013

4) **R/W**

- No R/W required
 - R/W required, parcels not identified
 - R/W required, parcels identified
 - R/W has been acquired
- Anticipated date or date of acquisition _____

5) **Railroad Involvement**

- No railroad involvement on project
- Railroad R/W Agreement required; negotiations not begun
- Railroad R/W Agreement required; negotiations have begun
- Railroad R/W Agreement is complete

6) **Construction Documents/Plan**

- Construction plans have not been started
 - Construction plans in progress
- Anticipated date or date of completion: _____
- Construction plans completed/approved

7) **Letting**

Anticipated Letting Date: December 2013

ATTACHMENT I - PROJECT CHRONOLOGY

Bridge No. 9 Chronology

1. 1922 Constructed for use as a dual railroad track structure
2. 1981 Railroad service was discontinued
3. 1986 City took over ownership of structure
4. 1986 HNTB perform an inspection and structural analysis
5. 1987 Several repairs were made
6. 1991 Pier protection was repaired
7. 1993 Railing and deck boards repaired
8. 1994 MnDOT performed an in-depth snooper inspection
9. 1994 Woodward-Clyde evaluated bridge as a potential historic structure
10. 1997 Collins Engineering performed under water inspection
11. 1999 Remodeled to provide for pedestrian and bicycle traffic (opened 2000)
12. 2000 Replaced navigation light system
13. 2001 City performed first in-depth fracture critical snooper inspection
14. 2006 City performed an in-depth fracture critical snooper inspection
15. 2006 Public Works submitted a capital budget request for \$6.4M to perform rehabilitation on the structure
16. 2007 Collins Engineering performed under water inspection
17. 2007 City and TKDA performed an in-depth fracture critical snooper inspection
18. 2008 SEH performed an in-depth snooper inspection
19. 2009 SEH prepared a Condition Study Report
20. Annual City performs route inspection
21. Annual City performs river sounding and produces scour analysis report

**ATTACHMENT J – CONDITION STUDY REPORT:
BRIDGE NO. 9 PEDESTRIAN BRIDGE
OVER MISSISSIPPI RIVER**

Condition Study Report

Bridge No. 9 Pedestrian Bridge over the Mississippi River

Minneapolis, Minnesota

SEH No. MNPLS 105066

March 31, 2009



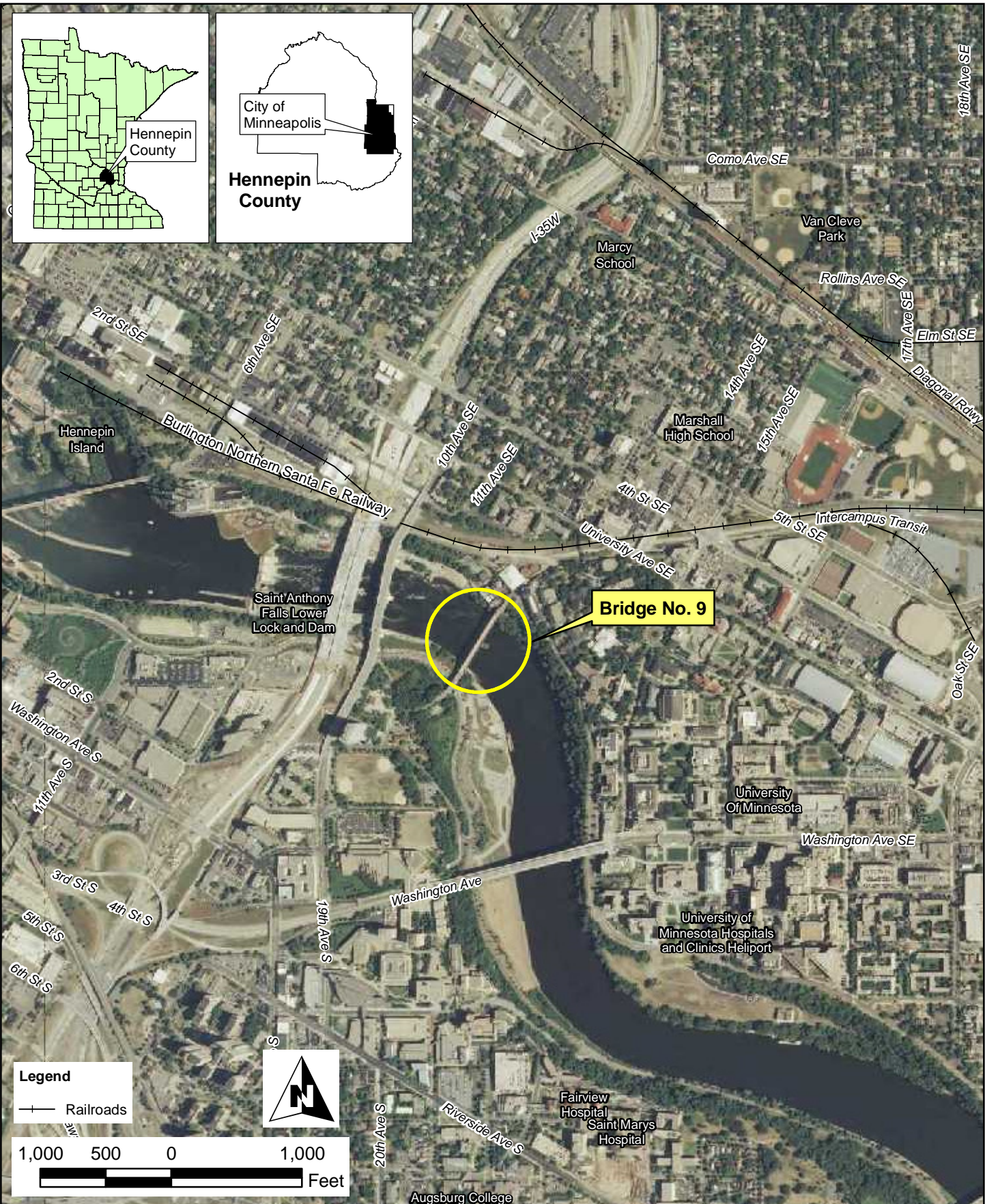
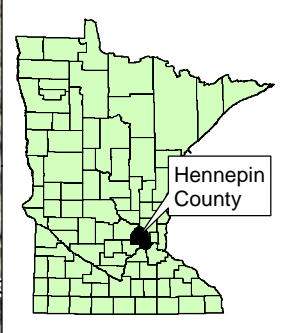

Bridge No. 9

Legend
 — Railroads

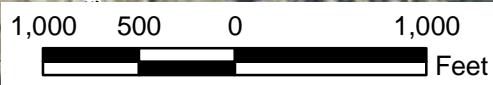

Map Document: (S:\K0MM\mpls\105066\GIS\Maps\Fig01_OverviewMap.mxd) 3/11/2008 -- 1:09:27 PM

	3535 VADNAIS CENTER DR. ST. PAUL, MN 55110 PHONE: (651) 490-2000 FAX: (651) 490-2150 WATTS: 800-325-2055 www.sehinc.com © SEH 2008	Project: DORSE105749 Print Date: 11/21/2008 Map by: SH Projection: UTM, Zone 15, NAD 83, m Source: USGS 7.5 Min. Topo, MnDOT, and SEH Inc.	<h2>Site Location</h2> <h1>Condition Study Report</h1> <h2>BRIDGE NO. 9 PEDESTRIAN BRIDGE</h2> <h3>Minneapolis, Minnesota</h3>

This map is neither a legally recorded map nor a survey map and is not intended to be used as one. This map is a compilation of records, information, and data gathered from various sources listed on this map and is to be used for reference purposes only. SEH does not warrant that the Geographic Information System (GIS) Data used to prepare are error free, and SEH does not represent that the GIS Data can be used for navigational, tracking, or any other purpose requiring exacting measurement of distance or direction or precision in the depiction of geographic features. The user of this map acknowledges that SEH shall not be liable for any damages which arise out of the user's access or use of data provided.

March 31, 2009

RE: Bridge No. 9 Pedestrian Bridge over the
Mississippi River
Condition Study Report
Minneapolis, Minnesota
SEH No. MNPLS 105066

Mr. Mike Kennedy, PE
Division of Transportation, Maintenance and Repair
City of Minneapolis
330 S 5th St., 203 City Hall
Minneapolis, MN 55415

Dear Mr. Kennedy:

Enclosed please find two copies of the Bridge No. 9 Pedestrian Bridge over the Mississippi River Condition Study Report. The enclosed report is submitted in accordance with our September 10, 2008 Engineering Agreement (Master Contract No. C-25367). An additional copy has been sent to Jeff Johnson for review and comment.

Also enclosed is a CD with an electronic file in PDF format of the Condition Study Report.

Sincerely,

Jeff A. Johnson, PE
Principal/Structural Project Manager

c: Mr. Jeff A. Johnson, PE (City of Minneapolis)

s:\ko\m\mnpls\105066\reports&specs\rdm\pls bridge no 9 condition study report.doc

Bridge No. 9 Pedestrian Bridge over the Mississippi River
Condition Study Report
Minneapolis, Minnesota

SEH No. MNPLS 105066

March 31, 2009

I hereby certify that this report was prepared by me or under my direct supervision, and that I am a duly Licensed Professional Engineer under the laws of the State of Minnesota.

Gaylen L. Perkuhn, PE

Date: March 31, 2009 Lic. No.: 15925

Reviewed by: Jeff A. Johnson, PE March 31, 2009
Date

Short Elliott Hendrickson Inc.
3535 Vadnais Center Drive
St. Paul, MN 55110-5196
651.490.2000

Executive Summary

Bridge No. 9, built in 1922 by the Northern Pacific Railroad, is a seven span steel deck bridge providing a railroad link between St. Paul and Minneapolis over the Mississippi River. The structure consists of two 245-foot steel deck trusses spanning the river, and five steel plate girder approach spans (three spans on the west bank, two spans on the east bank). The three approach spans located on the west bank are 90 feet long. The two approach spans on the east bank are 80 feet and 90 feet long. The total length of the bridge is 952 feet and the width is 24 feet. Reinforced concrete piers and abutments support the entire structure. When originally constructed, the bridge carried two sets of parallel tracks with simple pipe handrails along each side of the bridge.

In 1999, Bridge No. 9 was remodeled to convert the bridge usage to a bicycle and pedestrian facility. The remodeling included: removal of the old railroad ties and ballast; placement of granular material and bituminous wearing course pavement on the approach plate girder spans; placement of a 27-foot wide, 7-inch thick concrete deck on the main deck truss spans; installation of ornamental metal railing, deck lighting, navigation lighting, striping, and signing.

The primary goal of this inspection and evaluation report is to apprise the City of Minneapolis of the current physical condition and structural rating of Bridge No. 9. On September 18, 2008, the City of Minneapolis authorized SEH, Inc. to proceed with field inspection and load analysis/rating work to determine the current physical condition of Bridge No. 9, and to evaluate the feasibility for repairing the existing bridge. The scope of work excluded underwater inspection of the piers and inspection of the timber fenders that protect the river pier.

The field inspection was conducted from September 22, 2008 to September 24, 2008. The City of Minneapolis furnished a snooper vehicle with platform operator and truck driver to facilitate access to the main span steel deck trusses and the approach span steel plate girder superstructure and the bottom of the concrete deck. The portions of the bridge at the abutment and the pier substructures and the topside of the concrete deck were inspected on foot.

The field inspection of Bridge No. 9 included the following work activities:

- Perform visual inspection of all elements of the bridge and document findings in accordance with the AASHTO Manual for Condition Evaluation of Bridges; and
- Obtain two samples of existing coating system for hazardous material assessment.

The following observations were noted during the field inspection:

- The concrete surfaces at the ends of the caps for Piers 2 to 7 are deteriorated due to weathering and scaling. Reinforcing bars are exposed at a few pier locations. However, the concrete surfaces under the bearings are not affected to date.
- Water is leaking through the open longitudinal joints of the approach span ballast slab decks. This is causing calcium deposit buildups to form on the underside of the deck and on the steel members of the plate girders and causing corrosion and pack rust to form on the steel plate girders and the cross frame members adjacent to the open longitudinal joint. Water is also leaking through the transverse compression seals located over the piers of the approach spans causing corrosion and pack rust to form at the ends of the plate girders and the end frames.
- Concrete spalls with exposed reinforcement bars are located on the sides ballast slab and curb adjacent to the transverse deck joints.

Executive Summary (Continued)

- The fixed bearings and the expansion bearing assemblies of the main spans and the approach spans had some loose or bent anchor bolts. The bearings are dirty with excessive debris built up around the bearings on the concrete shelf.
- The paint coating system on steel members of the main span deck trusses and the approach span plate girders is in poor condition with excessive loss of coating system.

Both of the paint samples submitted for hazardous material assessment contained lead.

The structural rating analysis revealed that the truss is adequate to support the required 85 psf design live load for pedestrian and bicycle use in accordance with AASHTO Design Specifications. Since the bridge was originally designed for dual track railroad live load, the bridge components were also checked, rated, and found adequate for a single HS20 truck live load. No impact was applied to this single HS20 truck live load since the bridge is currently used to carry a multi-use trail for bicycles and pedestrians. Controlling members currently have minimal section loss due to corrosion. Members with light to moderate corrosion will be monitored during future routine bridge inspections.

In 1994, Woodward-Clyde conducted a historic evaluation of Bridge No. 9 (Mn/DOT S.P. 27-637-02, SHPO No. 94-2179). This historic evaluation determined that Bridge No. 9 is recommended eligible for nomination to the National Register of Historic Places.

Generally the bridge is in good condition but several items should be considered for repair or rehabilitation. Five rehabilitation items of most significance were identified. Estimates of project costs were determined for each of the five rehabilitation items. The five rehabilitation items and estimates of project costs are presented below:

▪ Item 1: Pier Repairs	\$ 412,000
▪ Item 2: Approach Spans Waterproofing and Ballast Curb Repairs	\$ 319,000
▪ Item 3: Abutment Repairs	\$ 25,000
▪ Item 4: Repair & Partial Paint Steel Superstructure and Clean/Repair Bearings	\$ 449,000
▪ Item 5: Install “No Vehicles Allowed” Sign on North Approach	\$ 500

It is our recommendation that Bridge No. 9 be rehabilitated by performing the recommended work listed for Items 1, 2, and 5 for a total cost of \$731,500. These items preserve the structural integrity of the bridge by repairing the deteriorated features with the most urgent needs of repair. Item 3 should be performed in 5 to 10 years and Item 4 should be performed in 10 to 15 years. Additional maintenance repairs will most likely need to be performed after 15 years as the structure is continuously inspected over the remaining life of the bridge. The City of Minneapolis should consider submitting Items 1, 2, and 5 as a possible inclusion as a project funded under the potential upcoming Federal Economic Stimulus Package with the goal of commencing construction in 2009.

Table of Contents

Letter of Transmittal
Certification Page
Title Page
Executive Summary
Table of Contents

	Page
1.0 Introduction	1
2.0 Bridge Condition Inspection Procedure	2
3.0 Bridge Condition Inspection Findings and Documentation	3
3.1 General Bridge Description.....	3
3.2 Existing Bridge Geometrics.....	4
3.3 Current Physical Condition of Bridge No. 9	4
3.3.1 Inspection Observations and Documentation.....	4
3.3.1.1 Main spans steel deck truss superstructure.....	4
3.3.1.2 Approach spans steel plate girder superstructure.....	6
3.3.1.3 Main spans concrete deck	6
3.3.1.4 Approach spans ballast slab with bituminous wearing course pavement	6
3.3.1.5 Ornamental Metal Railing	7
3.3.1.6 Substructure.....	7
3.3.1.7 Miscellaneous	8
3.3.2 Hazardous Material Assessment.....	8
3.3.3 Historical Significance of Existing Bridge	8
4.0 Structural Analysis and Rating	8
4.1 General	8
4.2 Structural Analysis and Rating Results.....	9
5.0 Bridge Rehabilitation Evaluation	10
5.1 Item 1: Pier Repairs	11
5.1.1 Scope of Work: (Refer to Figure 7)	11
5.2 Item 2: Approach Spans Waterproofing and Ballast Curb Repair.....	11
5.2.1 Scope of Work: (Refer to Figures 5 and 6).....	11
5.3 Item 3: Abutment Repairs	12
5.3.1 Scope of Work:.....	12
5.4 Item 4: Repair & Partial Paint Steel Superstructure and Clean/Repair Bearings 13	
5.4.1 Scope of Work:.....	13
5.5 Item 5: Install “No Vehicles Allowed” Sign on North Approach	14
5.5.1 Scope of Work:.....	14
6.0 Summary Of Project Costs	14

Table of Contents (Continued)

List of Figures

- Figure 1 – General Plan and Elevation
- Figure 2 – Typical Section
- Figure 3 – Typical Truss Section
- Figure 4 – Member Identification
- Figure 5 – Waterproofing Layout Plan
- Figure 6 – Waterproofing Details
- Figure 7 – Pier Details

List of Appendices

- Appendix A Photographs from Bridge Condition Inspections
- Appendix B Hazardous Material Assessment
- Appendix C Mn/DOT Structure Inventory and Bridge Inspection Reports



Elevation Photo: Looking South Towards Bridge No. 9

Condition Study Report

Bridge No. 9 Pedestrian Bridge over the Mississippi River

Prepared for Minneapolis, Minnesota

1.0 Introduction

This report summarizes the inspection and evaluation of the Bridge No. 9 Pedestrian Bridge over the Mississippi River in Minneapolis, Minnesota. Bridge No. 9 is also known as Bridge No. 94246 in Mn/DOT's Bridge Inventory List.

Bridge No. 9, built in 1922 by the Northern Pacific Railroad, is a seven span steel deck bridge providing a railroad link between St. Paul and Minneapolis over the Mississippi River. The structure consists of two 245-foot steel deck trusses spanning the river, and five steel plate girder approach spans (three spans on the west bank, two spans on the east bank). The three approach spans located on the west bank are 90 feet long. The two approach spans on the east bank are 80 feet and 90 feet long. The total length of the bridge is 952 feet and the width is 24 feet. Reinforced concrete piers and abutments support the entire structure. When originally constructed, the bridge carried two sets of parallel tracks with simple pipe handrails along each side of the bridge.

In 1960, the University of Minnesota placed a steam line at the bottom chord level of the main truss spans. The steam line services the University's west bank buildings.

After 1966, rail traffic on Bridge No. 9 was confined to a single track and the other track was removed. By 1981, rail traffic ceased completely and the bridge structure was abandoned. In 1986, the abandoned structure (including the rail corridor right-of-way) was sold to the City of Minneapolis by Burlington Northern Railroad Company (now Burlington Northern Santa Fe Railroad Company).

In 1999, Bridge No. 9 was remodeled to convert the bridge usage to a bicycle and pedestrian facility. The reconstruction included: removal of the old railroad ties and ballast; placement of granular material and bituminous wearing course pavement on the concrete ballast slab of the approach plate girder spans; placement of a 27-foot wide, 7-inch thick concrete deck on the

main deck truss spans; installation of ornamental metal railing, deck lighting, navigation lighting, striping, and signing.

Figures 1 through 4 depict the Bridge No. 9 in plan, elevation, and section views. Photos taken during the field inspection to document the current physical condition of the bridge are included in Appendix A.

The primary goal of this inspection and evaluation report is to apprise the City of Minneapolis of the current physical condition and structural rating of Bridge No. 9. Five bridge rehabilitation items are identified and addressed in the report. The five rehabilitation items evaluated are:

- Option 1: Pier Repairs
- Option 2: Approach Spans Waterproofing and Ballast Curb Repairs
- Option 3: Abutment Repairs
- Option 4: Repair & Partial Paint Steel Superstructure and Clean/Repair Bearings
- Option 5: Install “No Vehicles Allowed” Sign on North Approach

2.0 Bridge Condition Inspection Procedure

The field inspection of Bridge No. 9 Pedestrian Bridge over the Mississippi River included the following work activities:

1. Perform hands on inspection of all elements of the bridge and document findings in accordance with the AASHTO Manual for Condition Evaluation of Bridges;
 - the two main span steel deck truss and five approach span steel plate girder superstructures were visually inspected to determine the current physical condition of the steel members including loose or missing rivets, misaligned or damaged members, cracked plates, corrosion or deformation of structural components, coating system condition
 - the bearing assemblies for the deck truss and steel plate girder superstructures were visually inspected to determine the current physical condition of the bearing assembly components
 - concrete deck was visually inspected for defects such as cracks, spalls, exposed corroded reinforcing steel, and efflorescence.
 - ornamental metal railings were visually inspected for misaligned or bent members, coating system condition
 - concrete abutments and piers were visually inspected for cracks, spalls, corrosion of reinforcing steel, misaligned or damaged members, scour or erosion and the concrete surfaces were sounded with a chipping hammer for delaminations in the vicinity of cracks and spalls. Primary focus was on the pier caps.
2. Obtain two samples of existing coating system for hazardous material assessment.

This inspection scope of work did not include: underwater inspection of the piers; inspection of the timber fenders that protect the river pier; and inspection of the steam pipe and electrical utilities on the bridge.

The field inspection was conducted from September 22, 2008 to September 24, 2008. The City of Minneapolis furnished a snooper vehicle with platform operator and truck driver to facilitate access to the main span steel deck trusses and the approach span steel plate girder superstructure and the bottom of the concrete deck. The portions of the bridge at the abutment and the pier substructures and the topside of the concrete deck were inspected on foot.

Standard tools and equipment used during the field inspection consisted of chipping hammers, wire brushes, pocket tapes, flashlights, marking crayons, safety harnesses, hard hats, shovel, and plastic bags for paint sample collection. Special equipment used included an ultrasonic thickness gauge used to measure existing steel thickness to hundredths of an inch, a snooper vehicle, and a digital camera.

3.0 Bridge Condition Inspection Findings and Documentation

3.1 General Bridge Description

Bridge No. 9 over the Mississippi River in Minneapolis, Minnesota, (Mn/DOT Bridge No 94246) consists of first and second generation structural components. In the late 1880's the Northern Pacific Railroad constructed a river crossing at the location of the Bridge No. 9. In 1922 a second bridge, Bridge No. 9, was constructed using portions of the original bridge. A center truss was added between the original (late 1880's) pair of trusses for the two main spans. Other original bridge members reused in the 1922 construction included: floor beams; stringers; lateral bracing; and truss expansion joints. The original approaches, the approach spans, and the substructure units were replaced in the 1922 construction resulting in a bridge structure consisting of three west approach spans of approximately 90 foot length on a curved horizontal alignment, two main spans of approximately 249 foot length on a tangent horizontal alignment, and two east approach spans of approximately 84 foot length. The 1922 construction was designed for and carried dual railroad tracks.

The bridge remained in service for railroad traffic until 1981. In 1999, the bridge was remodeled and reopened to carry pedestrian traffic across the Mississippi River. The decks and the railings were reconstructed. The truss span's railroad decks were removed and replaced with a concrete deck. In the approach spans, concrete rail parapets were placed adjacent to the existing concrete ballast slab curbs on both sides to permit anchorage of the new ornamental metal railing and light poles. Granular base fill topped with bituminous wearing course pavement was placed between the new concrete parapets in the existing ballast slabs of the approach spans. Ornamental railing and lights were added full length of the bridge on both sides.

Bridge No. 9 is classified as a Fracture Critical Bridge. The bridge has been routinely inspected as required by Mn/DOT. A Fracture Critical Bridge is defined as having at least one fracture critical member or member

components. Fracture critical members are steel tension members whose failure would be expected to result in the collapse of the bridge.

3.2 Existing Bridge Geometrics

Plans for the original (1880's) bridge construction, the 1922 bridge construction, and the 1999 bridge remodeling are available and were used in computer modeling the bridge for the structure rating. Figures 1 through 4 depict Bridge No. 9 in plan, elevation, and section views.

3.3 Current Physical Condition of Bridge No. 9

During the bridge condition inspection conducted from September 22, 2008 to September 24, 2008, the current physical condition of Bridge No. 9 was compared previous inspection findings. The previous inspection reports referenced are as follows:

- A. Burlington Northern Bridge No. 9 Inspection and Analysis Report dated February 10, 1986 (prepared by HNTB);
- B. Mn/DOT Structure Inventory Report for Bridge ID94246 (Bridge No. 9);
- C. Mn/DOT Bridge Inspection Report for Bridge ID94246 (Bridge No. 9);
- D. First Inspection of Fracture Critical Bridge Report for Bridge No. 9 dated June 11, 2001 (prepared by City of Minneapolis);
- E. Inspection of Fracture Critical Bridge Report for Bridge No. 9 dated September 26, 2006 (prepared by City of Minneapolis);
- F. Bridge Inspection Peer Review Report for Bridge No. 9 dated August 10, 2007 (prepared by TKDA); and
- G. Underwater Bridge Inspection Report for Bridge No. 9 dated June 30, 2008 (prepared by Collins Engineers, Inc).

No new or significantly advancement of defects were noted during this bridge condition inspection. The current physical condition essentially matches the condition noted in the Mn/DOT Bridge Inspection Reports.

Refer to Appendix C for the bridge inspection reports noted in Items B to G above for Bridge No. 9.

3.3.1 Inspection Observations and Documentation

3.3.1.1 Main spans steel deck truss superstructure

As described above, the 245-foot main spans are a hybrid trusses consisting of first and second generation structural components. The two outside trusses are from the 1880's. The center trusses were added in 1922.

The outside trusses are of the pin and eyebar type which was typically used in the late 1800's and early 1900's. The tension members are constructed of bars and the compression members are built-up riveted sections. All members are pin connected.

The center truss consists of built-up riveted sections for all members with rigid connections.

The lower lateral and sway bracing are pinned members with turnbuckles used for adjustment. The upper lateral bracing consists of parallel angles placed back-to-back connected to the top chord by gusset plates. The inclined posts of the trusses are braced with two sets of lateral bracing consisting of parallel back-to-back angles placed symmetrical about midpoint of the end posts.

The floor beams from the 1880's construction were reconstructed for use in the 1922 construction. The reconstruction consisted of increasing the length of the floor beams and re-drilling stringer connection rivet holes.

Stringers from the 1880's construction were used in the 1922 construction. It appears that all of the original stringers were placed in the east truss due to increase in design loading at half the original spacing. New stringers of heavier section were fabricated for the west truss and placed at the original stringer spacing.

Stringers frame into the sides of the floor beams and are supported by clip angles on each side of the web. The end span stringers bear on expansion assemblies at the approach girder end diaphragms.

Floor beams bear upon the top chord of the trusses at the panel point locations. There are also two floor beams over Pier 4 which are supported by three columns each.

The ends of the floor beams are connected to gusset plates between the floor beams and the top chord. The gusset plates are symmetrical about the centerline of the web of the floor beams at all panel points except at the end panel points U1 and U7 where the gusset plates extend inward towards the center of the truss.

Inspection of the floor beams, stringers, and the truss members revealed the following:

1. The paint coating system on steel members of the deck truss superstructure is in poor condition with excessive loss of coating system.
2. No significant section loss due to corrosion or pack rust was observed in any of the primary truss members.
3. A number of the counters in the trusses were found to be bowed, deformed, and loose due to no tension in the members.
4. The fixed bearings and expansion bearing assemblies had some loose or missing anchor bolts. The bearings are dirty with excessive debris built up around the bearings on the concrete shelf.
5. Majority of the lower lateral bracing members have little or no section loss but some are loose and may need adjustment.
6. For the top lateral bracing and the end post lateral bracing, some pack rust has developed between the back-to-back legs of the angles resulting in some section loss.
7. Some pack rust occurs at the splice plates of the floor beams with no significant section loss.

-
8. At the expansion assemblies supporting the end span stringers, there are some locations with pack rust on the sliding plates and some anchor bolts are loose.

The steam line supports /connections and the steel walkway platform at the bottom chord level of the truss are in good condition.

3.3.1.2 Approach spans steel plate girder superstructure

The approach steel plate girders are arranged in five spans of four girders each. The three west approach spans are approximately 90-foot long, varying with the horizontal curve of the deck. The two east approach spans are 80 and 85 feet long.

The girders were found to be typically in good condition with little or no corrosion and pack rust. The two girders in each span adjacent to the open longitudinal joint in the concrete ballast slab deck typically had minor corrosion on the top flange and the top surface of the bottom flange due to water leaking through the open longitudinal joint. Calcium deposits had formed at a few locations on the girders in the west approach spans.

The steel members of the cross frames, the end frames, and their gusset plate connections were in generally good condition with little or no corrosion and pack rust. Most of the corrosion found was located in the center bay with the open longitudinal deck joint that is leaking water.

The paint coating system on steel members of the approach steel plate girders superstructure is in poor condition with excessive loss of coating system.

The fixed bearings and the expansion bearing assemblies had some loose or bent anchor bolts. The bearings are dirty with excessive debris built up around the bearings on the concrete shelf.

3.3.1.3 Main spans concrete deck

The main spans concrete deck was constructed in 1999. The strip seal expansion joints at Piers 3, 4, and 5 and the ½” sawcut transverse joints in the top of the concrete deck filled with joint sealant over each floor beam were included in this reconstruction. The concrete deck and the joints are in good condition.

3.3.1.4 Approach spans ballast slab with bituminous wearing course pavement

The existing ballast slab decks of the approach spans were reconstructed in 1999. The reconstruction consisted of removing the old ties and ballast, adding concrete parapets adjacent to and against the existing ballast slab curbs on both sides for the ornamental metal railing anchorage, placement of new granular fill and bituminous wearing course pavement between the new concrete parapets, placement of new ornamental metal railing on both sides, and placement of new transverse compression seal joints at the pier locations.

The top surface of the bituminous wearing course pavement has a number of longitudinal and transverse cracks. Depression ruts have formed a few feet away from the edge of the concrete parapets. There are a few locations that have evidence of water ponding on the bituminous surface.

Water is leaking at the transverse compression seal joints at the piers.

Inspection of the underside of the existing concrete ballast slab deck revealed reinforcement bars exposed at isolated bottom surface spall locations, and isolated transverse and longitudinal cracks with efflorescence adjacent to the cracks.

Concrete spalls with exposed reinforcement bars are located at the transverse deck joint locations over the piers.

Isolated concrete spalls with exposed reinforcement bars are located on the sides of the ballast slab and curb. Most are located adjacent to the transverse deck joint locations over the piers.

3.3.1.5 Ornamental Metal Railing

The ornamental metal railing was installed in 1999. The railing is in good condition with isolated locations of corrosion. Water entered the expansion areas of the railing and collected in the rail posts causing the rail posts to crack during freeze conditions. The paint system on the metal railing has faded in color and has isolated locations where the paint system has failed due to the thermal cracking of the rail posts. There are paint patches present on the railing that were placed to cover graffiti on the ornamental metal railing.

3.3.1.6 Substructure

The substructure for Bridge No. 9 was constructed in 1922. The substructure consists of two abutments, five land piers, and one river pier. All substructure have spread footing foundations bearing on sandstone. In general, all of the substructure units are in fair condition except as noted below.

East abutment (east bank): Concrete is in fair condition. The surfaces of the wingwalls have a fair amount of scaling and spalling. The north and south ends of the bearing caps have concrete scaling and small cracks. The top surface of the bearing seat is covered with stone and aggregate debris. There is a build up of trees at this abutment

All piers are in fair condition.

Pier 2: Concrete bearing cap is deteriorating (scaling) at north and south ends. Shaft cracks on west side.

Pier 3 and 5: Concrete bearing cap is deteriorating (scaling) at north and south ends.

Pier 4: Concrete bearing cap is deteriorating (scaling) at north and south ends. Shaft cracks on east side.

Pier 6: Concrete bearing cap is deteriorating (scaling) at south end. Cracks in bearing cap between center bearings north side.

Pier 7: Concrete bearing cap is deteriorating (scaling) at north and south ends. Minor cracks developing in the concrete shaft below the concrete bearing cap.

The deterioration of the pier caps have not affected the concrete surfaces under the bearings to date.

West abutment (west bank): Concrete is in fair condition. There are exposed timber form ties from 1922 construction. Minor scaling of concrete on south wingwall. Heavy graffiti painted on exposed abutment concrete surfaces under the bridge.

3.3.1.7 Miscellaneous

No “No Vehicles Allowed” signs posted on roadway adjacent to east abutment.

3.3.2 Hazardous Material Assessment

Two samples of the existing coating system were sent to Corrosion Control Consultants and Labs, Inc in Kentwood, Michigan for hazardous material assessment testing. The results of the sample testing are as follows:

1. North fascia beam, exterior face, 2nd approach span from east abutment:

Element	Result by weight	Reporting Limit
Cadmium	<RL	0.00075%
Chromium	0.085%	0.0013%
Lead	9%	0.0050%

2. South fascia beam, exterior face, 1st approach span from west abutment:

Element	Result by weight	Reporting Limit
Cadmium	<RL	0.00075%
Chromium	0.23%	0.0013%
Lead	15%	0.0050%

Refer to Appendix B for the Analytical Laboratory Report submitted by Corrosion Control Consultants and Labs, Inc.

The University of Minnesota steam line on the bridge used to be covered with insulation containing asbestos. This insulation has been removed and replaced with insulation material not containing asbestos per personnel from the University of Minnesota.

No other regulated materials/waste other than lead paint were observed. The lead paint material must be properly handled and disposed of during bridge rehabilitation.

3.3.3 Historical Significance of Existing Bridge

In 1994, Woodward-Clyde conducted a historic evaluation of Bridge No. 9 (Mn/DOT S.P. 27-637-02, SHPO No. 94-2179). This historic evaluation determined that Bridge No. 9 is recommended eligible for nomination to the National Register of Historic Places.

4.0 Structural Analysis and Rating

4.1 General

The structural analysis and load rating procedures used for Bridge No. 9 followed the guidelines stated in the AASHTO Manual For Condition

Evaluation of Bridges. In accordance with the AASHTO guidelines, the bridge was rated at two levels, Inventory and Operating levels. The Inventory level generally corresponds to the customary design level of stresses but reflects the existing bridge and material conditions with regard to deterioration and loss of section. Load ratings based on the Inventory level result in a live load intensity which can be safely used for an indefinite period of time. Load ratings based on the Operating level generally describe the maximum permissible live load intensity to which the structure may be subjected. Allowing unrestricted live loads at this intensity may shorten the life of the bridge.

In order to check the live load effects on the individual truss and deck members, the allowable stress (AS) method was used to compute the Inventory and Operating rating factors.

A pedestrian live load of 85 pounds per square foot (psf) was used to compute the Inventory and Operating rating factors. No live load impact was applied to this pedestrian live load in accordance with the AASHTO Design Specifications.

Since the bridge was originally designed for dual track railroad live load, the bridge components were also checked, rated, and found to be adequate for a single HS20 truck live load. No impact was applied to this single HS20 truck live load since the bridge is currently used to carry a multi-use trail for bicycles and pedestrians.

For the components of the bridge fabricated in 1922, the allowable stresses of the steel members are based on a tensile strength (F_u) of 60 kips per square inch (ksi) and a yield stress (F_y) of 30 ksi in accordance with the AASHTO guidelines. These members include the center deck truss, the approach steel plate girders, the west truss main span steel stringers and portions of the lateral bracing.

For the components of the bridge fabricated in the 1880's, the allowable stresses of the steel members are based on a tensile strength (F_u) of 52 kips per square inch (ksi) and a yield stress (F_y) of 26 ksi in accordance with the AASHTO guidelines. These members include the outside deck trusses, floor beams, east truss main span steel stringers, and portions of the lateral bracing.

The concrete ballast slabs for the five approach steel plate girder spans were constructed in 1922. The concrete deck for the two main deck truss spans was constructed in 1999.

4.2 Structural Analysis and Rating Results

The steel deck trusses with the floor beam and stringers were analyzed using three-dimensional structural members with the transverse members and bracing members included in the structural model. Dead loads, live loads, and wind loads in accordance with the AASHTO Design Specifications were applied to the three-dimensional truss model. Since the steel deck truss system was originally designed for dual track railroad live loading, the resulting truss system was stable and effective in resisting lateral wind loads and pedestrian live loads.

The approach span steel plate girders were analyzed as two-dimensional structural members as allowed per the AASHTO Design Specifications.

The lowest Inventory and Operating rating factors for the main spans steel deck truss members, the approach spans steel plate girder members, and the concrete deck are as follows:

Rated Element	Pedestrian Live Load		HS20 Truck Live Load	
	Inventory Rating	Operating Rating	Inventory Rating	Operating Rating
Truss Deck Span	2.8 ³	4.3 ³	12.7 ³	19.9 ³
Girder Approach Span	6.2 ¹	10.7 ¹	3.6 ²	6.1 ²
Concrete Deck	18.7	29.3	1.1	1.8

¹ 85-foot span interior girder controls using the AS method.

² 80-foot span exterior girder controls using the AS method.

³ Top chord member in compression controls using the AS method.

The member locations with the controlling rating factors are in good condition with minimal section loss. The members with section loss, heavy corrosion, and other deterioration are at locations with low stress levels and have relatively high rating factors.

Since the existing cast-in-place concrete abutments and piers below the bearing seat caps are massive and in relatively good condition with minimal signs of defects or distress, no rating analysis was conducted on the substructure units.

5.0 Bridge Rehabilitation Evaluation

Based on field inspection findings and/or structural capacity rating results, quantitative and qualitative conclusions can be drawn regarding the condition of various components of the bridge. The condition of any given component, together with its effect on the function of the bridge, dictate if and to what extent repairs are warranted. It is recommended that five repair/rehabilitation items be addressed as follows:

- Item 1: Pier Repairs
- Item 2: Approach Spans Waterproofing and Ballast Curb Repair
- Item 3: Repair & Partial Paint Steel Superstructure and Clean/Repair Bearings
- Item 4: Abutment Repairs
- Item 5: Install “No Vehicles Allowed” Sign on North Approach

Scope of work and estimated project costs for each of the evaluation items are as follows:

5.1 Item 1: Pier Repairs
5.1.1 Scope of Work: (Refer to Figure 7)

1. Remove unsound deteriorated concrete to sound concrete on the top and sides of existing pier caps (Piers 2 to 7). Do not undermine the existing seat surfaces under the bearing surfaces. If required remove existing concrete as required to form adequate trenches in the top of the pier cap for installation of the transverse post-tensioning ducts.
2. Where possible, prepare existing reinforcement bars for placement of non-shrink grout. Make sure 1/2" of cover is provided under the existing reinforcement bars.
3. Drill and epoxy grout into place new reinforcement bars as required
4. Place transverse post-tensioning ducts as required.
5. Where required, repair existing cracks greater than 1/16" in width by epoxy injection repair techniques.
6. Place non-shrink grout (f'c = 7,000 psi minimum) or conventional concrete (f'c = 4,000 psi minimum) in larger areas. Finish the patch surfaces and continuously cure the concrete patches for the required cure period and until the concrete patch material has attained adequate compression strength.
7. If required, core drill holes in the concrete pier cap for the transverse post-tensioning ducts.
8. Temporarily support all walers and install post-tensioning strands or bars. Partially stress each post-tensioning tendon to make sure the walers are seated properly. Stress all post-tensioning tendons to the maximum desired force in accordance with the PT suppliers submitted stressing sequence.
9. Prepare the post-tensioning tendons for grouting.
10. Grout the post-tensioning tendons.

<u>Approximate Construction Cost:</u>	
Concrete repairs & PT system for Piers 2 to 7	\$220,500
Mobilization @ 10%	\$ 22,500
General Conditions @ 15%	<u>\$ 33,500</u>
Subtotal	\$276,500
Contingency @ 10%	<u>\$ 28,000</u>
Total Construction Cost	\$304,500
Total Project Cost (\$ 304,500 X 1.35) =	\$412,000

Design and construction administration costs of 35% were added to the construction cost estimates to arrive at a project cost.

5.2 Item 2: Approach Spans Waterproofing and Ballast Curb Repair
5.2.1 Scope of Work: (Refer to Figures 5 and 6)

1. Remove existing bituminous wearing course pavement and granular fill in the ballast slab of the approach spans. Salvage granular fill.

2. Prepare the existing concrete surfaces of the concrete parapet and the ballast slab decks for the membrane waterproofing system.
3. Install the ballast slab waterproofing system.
4. Install new ballast slab drainage system along both sides of deck.
5. Backfill and compact granular fill (salvaged).
6. Place new bituminous wearing course pavement.
7. Remove unsound deteriorated concrete to sound concrete on the sides and underside of ballast slab deck and curb.
8. Where possible, prepare existing reinforcement bars for placement of non-shrink grout. Make sure ½” of cover is provided under the existing reinforcement bars.
9. Drill and epoxy grout into place new reinforcement bars as required.
10. Place non-shrink grout ($f'c = 7,000$ psi minimum). Finish the patch surfaces and continuously cure the concrete patches for the required cure period and until the concrete patch material has attained adequate compression strength.

Approximate Construction Cost:

Installation of approach spans waterproofing and ballast slab sides repair	\$170,900
Mobilization @ 10%	\$ 17,500
General Conditions @ 15%	<u>\$ 26,000</u>
Subtotal	\$214,400
Contingency @ 10%	<u>\$ 21,500</u>
Total Construction Cost	\$235,900
Total Project Cost (\$ 235,900 X 1.35) =	\$319,000

Design and construction administration costs of 35% were added to the construction cost estimates to arrive at a project cost.

5.3 Item 3: Abutment Repairs

5.3.1 Scope of Work:

1. Remove unsound deteriorated concrete to sound concrete on the top and sides of existing abutment seat caps (West and East Abuts). Do not undermine the existing seat surfaces under the bearing surfaces. If required remove existing unsound concrete as required on the exterior exposed surfaces of the wingwalls.
2. Where possible, prepare existing reinforcement bars for placement of non-shrink grout. Make sure ½” of cover is provided under the existing reinforcement bars.
3. Drill and epoxy grout into place new reinforcement bars ducts as required.
4. Where required, repair existing cracks greater than 1/16” in width by epoxy injection repair techniques.
5. Place non-shrink grout ($f'c = 7,000$ psi minimum). Finish the patch surfaces and continuously cure the concrete patches for the required cure

period and until the concrete patch material has attained adequate compression strength.

6. Where required, remove trees whose trunks are within 3-feet of the concrete surfaces of the abutment at the groundline.

Approximate Construction Cost:

Concrete repairs and tree removal at abutments	\$12,820
Mobilization @ 10%	\$ 1,500
General Conditions @ 15%	<u>\$ 2,000</u>
Subtotal	\$16,320
Contingency @ 10%	<u>\$ 2,000</u>
Total Construction Cost	\$ 18,320
Total Project Cost (\$ 18,320 X 1.35) =	\$ 25,000

Design and construction administration costs of 35% were added to the construction cost estimates to arrive at a project cost.

5.4 Item 4: Repair & Partial Paint Steel Superstructure and Clean/Repair Bearings

5.4.1 Scope of Work:

1. Prepare for removal of existing coating system that contains lead from the approach span plate girders where partial removals and partial painting will be applied. All of the surfaces of the two steel plate girders adjacent to the open longitudinal joint will be painted. All of the surfaces of the remaining approach span plate girders along with the end frames will be painted to the limits of 10 feet from the center line of the piers each way and to the limits of 10 feet from the end of the girders at the abutments.
2. Enclose, contain, and dispose of the hazardous waste material generated during removal of the existing coating system.
3. Prepare, clean, lubricate, and paint all bearing assemblies.
4. Remove and replace lateral bracing secondary members with excessive section loss due to formation of corrosion and pack rust. Use high strength bolts for the connections in lieu of rivets. The new lateral bracing members will be painted.
5. Where possible, tighten loose lateral bracing members and counters.
6. Place new coating system to the steel surfaces identified for the new coating system.

Approximate Construction Cost:

Spot removal and disposal of haz. material and spot application of new coating system, and clean & lub existing bearings	\$240,500
Mobilization @ 10%	\$ 24,500
General Conditions @ 15%	<u>\$ 36,500</u>
Subtotal	\$301,500
Contingency @ 10%	<u>\$ 30,500</u>
Total Construction Cost	\$332,000
Total Project Cost (\$ 332,000 X 1.35) =	\$449,000

Design and construction administration costs of 35% were added to the construction cost estimates to arrive at a project cost.

5.5 Item 5: Install “No Vehicles Allowed” Sign on North Approach

5.5.1 Scope of Work:

1. Install “No Vehicles Allowed” sign and sign post adjacent to the curb and gutter at the northeast corner of the bridge.

Approximate Construction Cost:

Install “No Vehicles Allowed sign and sign post	\$ 250
Mobilization @ 10%	\$ 30
General Conditions @ 15%	\$ 40
Subtotal	\$ 320
Contingency @ 10%	\$ 30
Total Construction Cost	\$ 350
Total Project Cost (\$ 350 X 1.35) =	\$ 500

Design and construction administration costs of 35% were added to the construction cost estimates to arrive at a project cost.

6.0 Summary Of Project Costs

■ Item 1:	Pier Repairs	\$412,000
■ Item 2:	Approach Spans Waterproofing and Clean/Repair Bearings	\$319,000
■ Item 3:	Abutment Repairs	\$ 25,000
■ Item 4:	Repair & Partial Paint Steel Superstructure and Clean/Repair Bearings	\$449,000
■ Item 5	Install “No Vehicles Allowed” Sign	\$ 500

It is our recommendation that Bridge No. 9 be rehabilitated by performing the recommended work listed for Items 1, 2, and 5 for a total cost of \$731,500. These Items preserve the structural integrity of the bridge by repairing the deteriorated features with the most urgent needs of repair. Option 3 should be performed in 5 to 10 years and Option 4 should be performed in 10 to 15 years. Additional maintenance repairs will most likely need to be performed after 15 years as the bridge is continuously inspected over the remaining life of the bridge. The City of Minneapolis should consider submitting Items 1, 2, and 5 as a possible inclusion as a project funded under the potential upcoming Federal Economic Stimulus Package with the goal of commencing construction in 2009.

List of Figures

Figure 1 – General Plan and Elevation

Figure 2 – Typical Section

Figure 3 – Typical Truss Section

Figure 4 – Member Identification

Figure 5 – Waterproofing Layout Plan

Figure 6 – Waterproofing Details

Figure 7 – Pier Details



LIST OF SHEETS	
NO.	DESCRIPTION
1	GENERAL PLAN AND ELEVATION
2	TYPICAL SECTIONS AND QUANTITIES
3	TYPICAL TRUSS SECTION
4	TRUSS MEMBER IDENTIFICATIONS
5	WATERPROOFING LAYOUT PLAN
6	WATERPROOFING DETAILS
7	PIER DETAILS

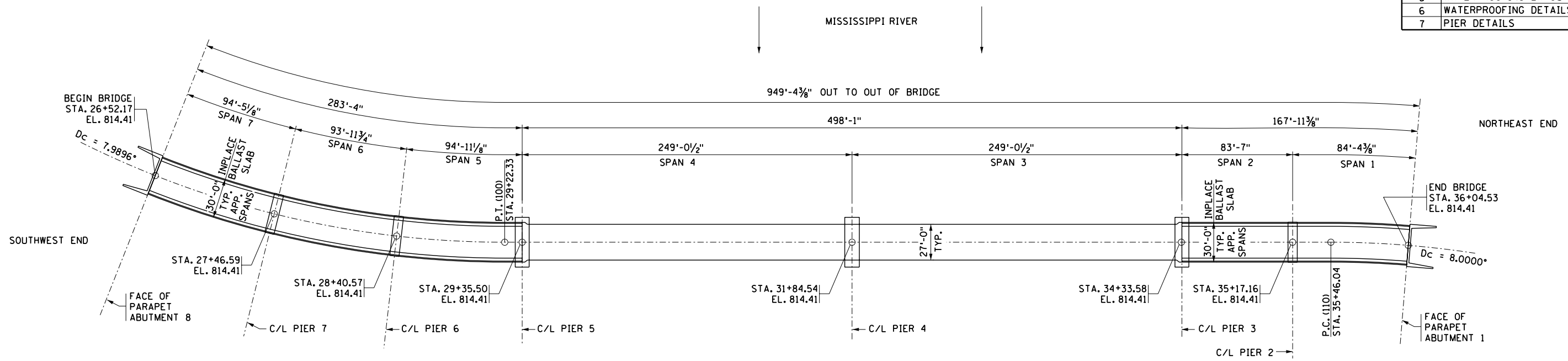

GENERAL PLAN

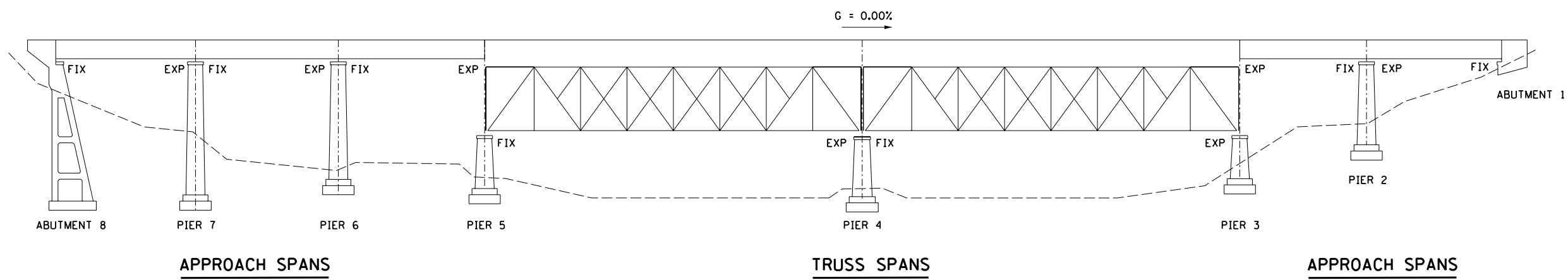

GENERAL ELEVATION

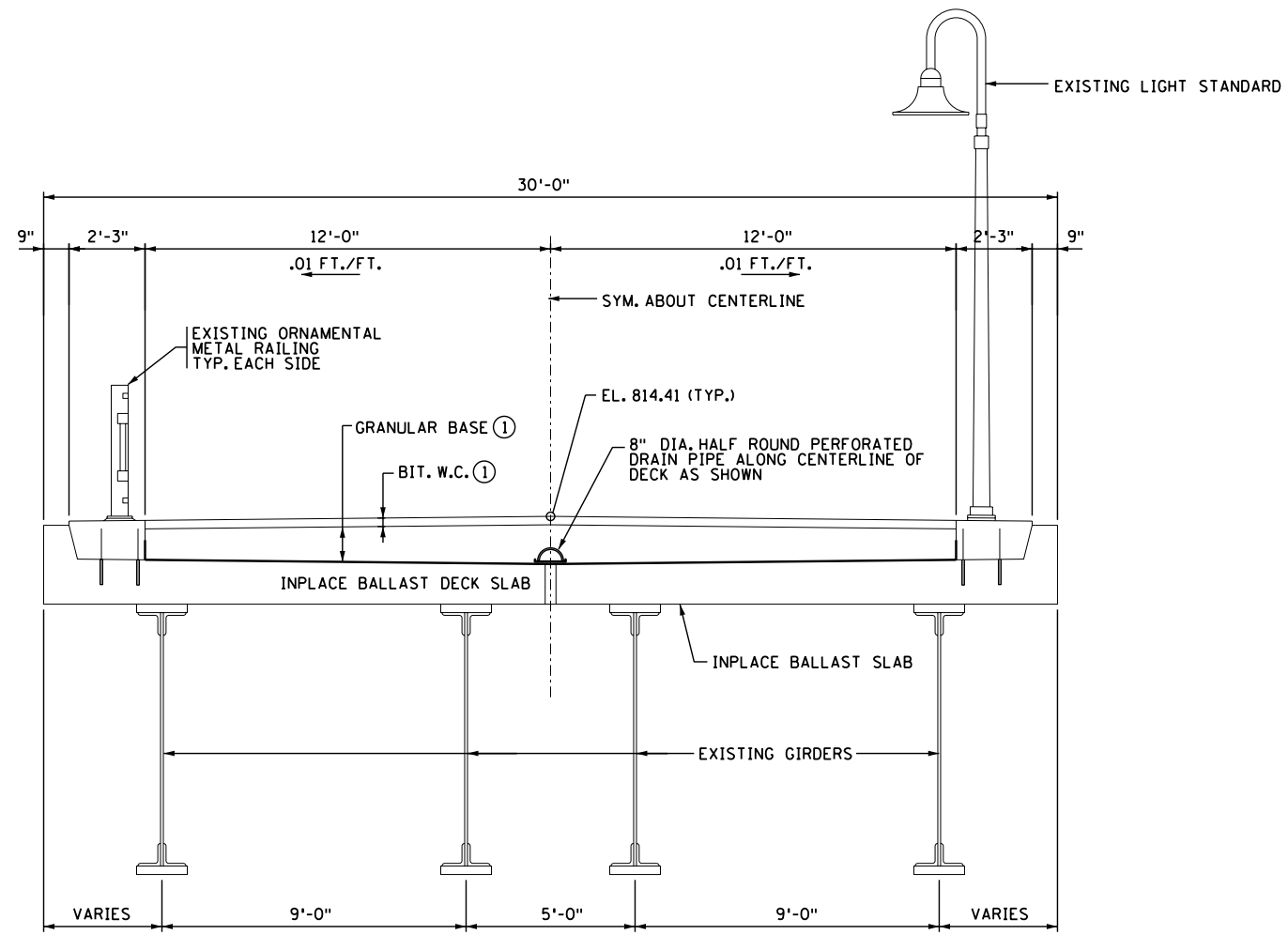

① REMOVE AND REPLACE

TYPICAL TRANSVERSE SECTION AT APPROACH SPANS

INPLACE BRIDGE 94246

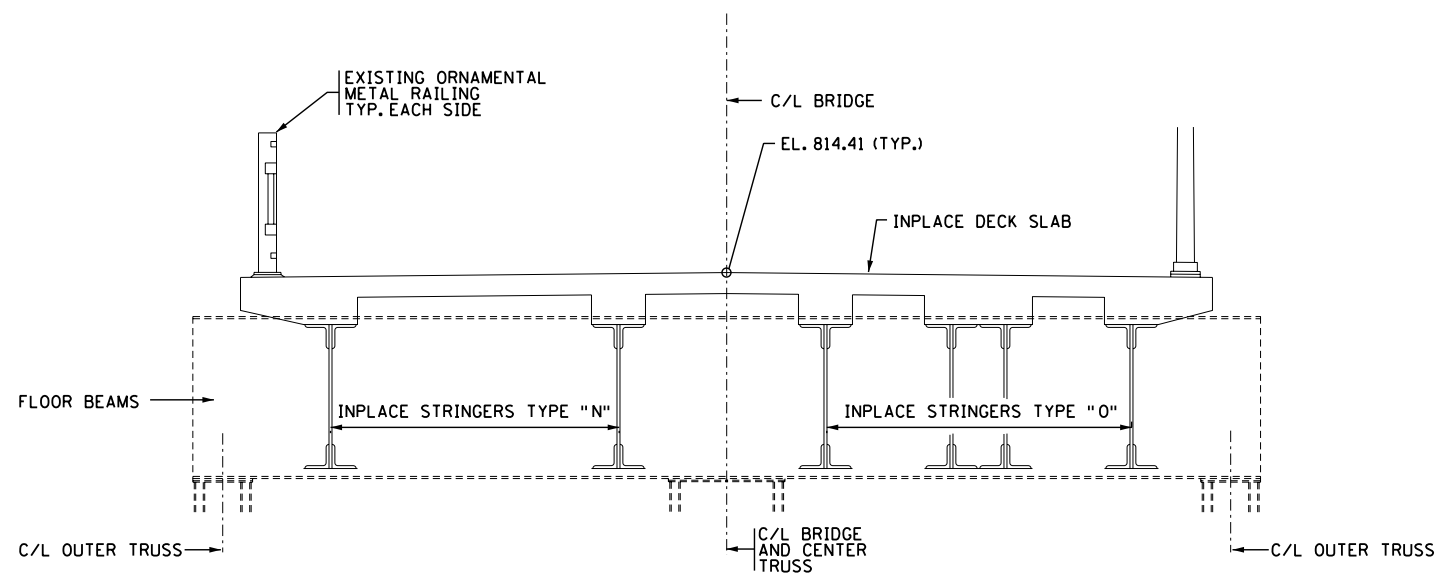

TYPICAL TRANSVERSE SECTION AT TRUSS SPANS

TYPICAL SECTION

BRIDGE NUMBER 94246 DINKYTOWN BIKEWAY CONNECTION
OVER THE MISSISSIPPI RIVER AT THE UNIVERSITY OF MINNESOTA IN MINNEAPOLIS

TYPICAL SECTION &
SUMMARY OF QUANTITIES

FIGURE NO.
2

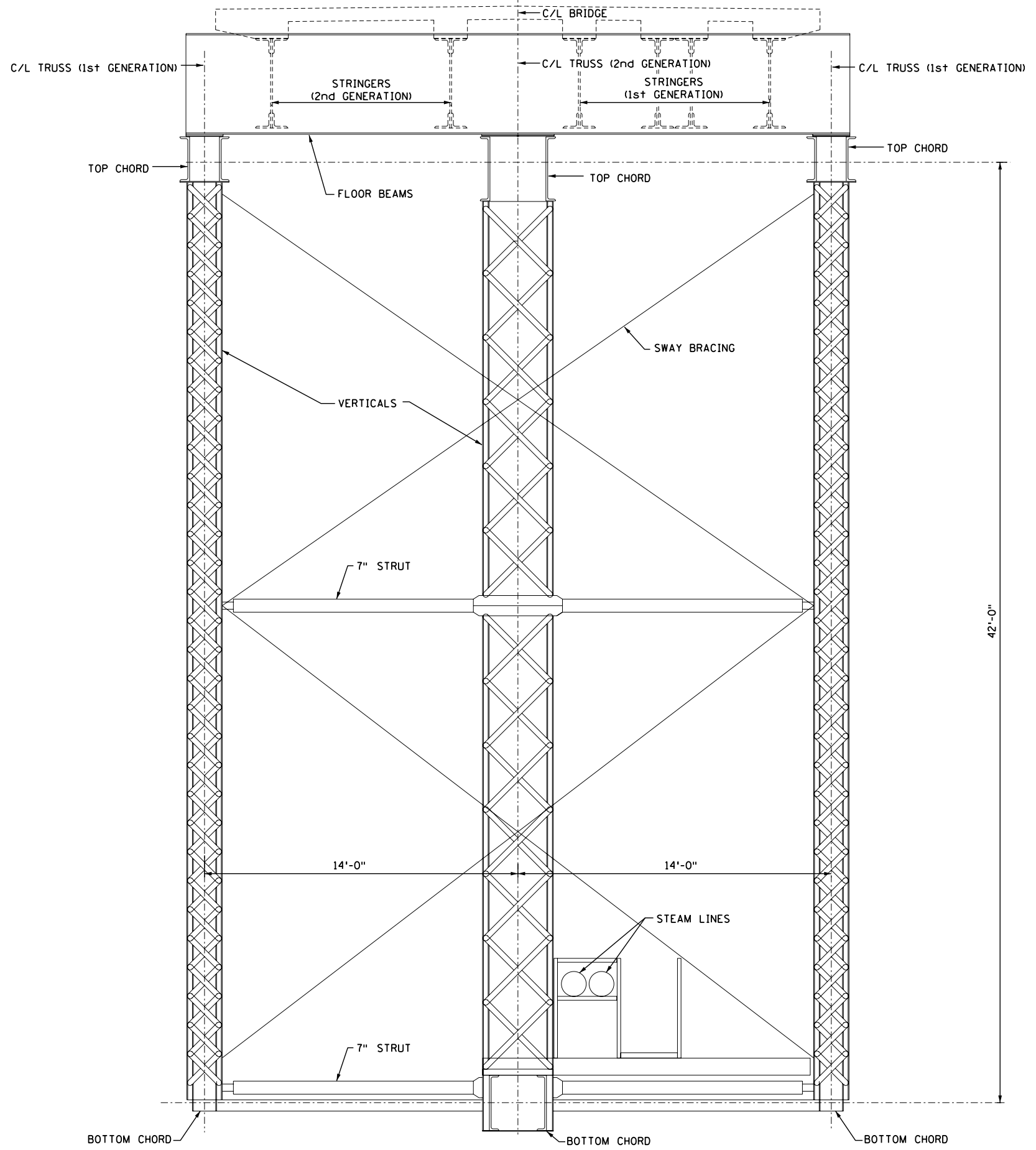

42'-0"

TYPICAL TRANSVERSE SECTION AT TRUSS SPANS

TYPICAL TRUSS SECTION

BRIDGE NUMBER 94246 DINKYTOWN BIKEWAY CONNECTION
OVER THE MISSISSIPPI RIVER AT THE UNIVERSITY OF MINNESOTA IN MINNEAPOLIS

FIGURE NO.
3

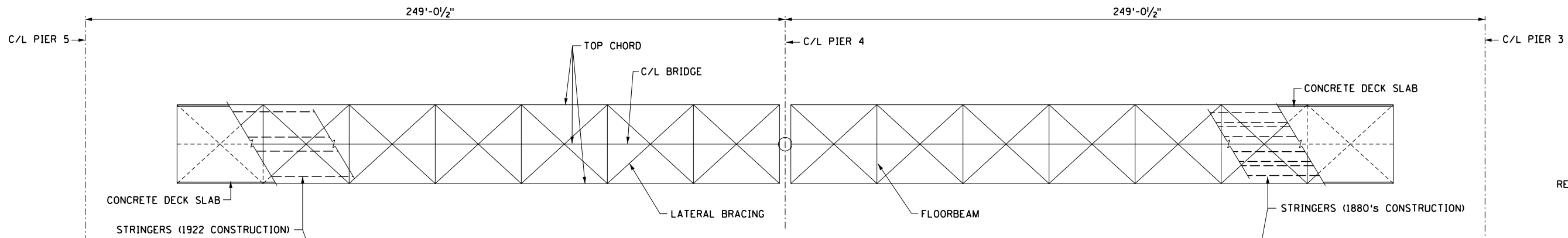

PLAN AT TOP CHORDS

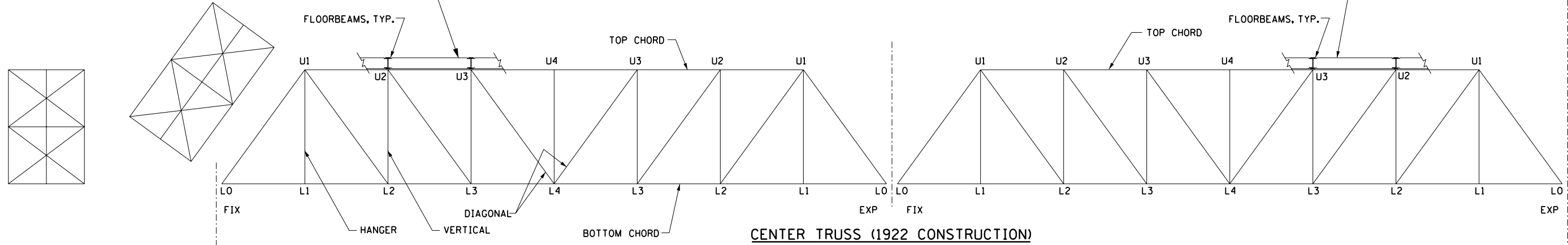

CENTER TRUSS (1922 CONSTRUCTION)

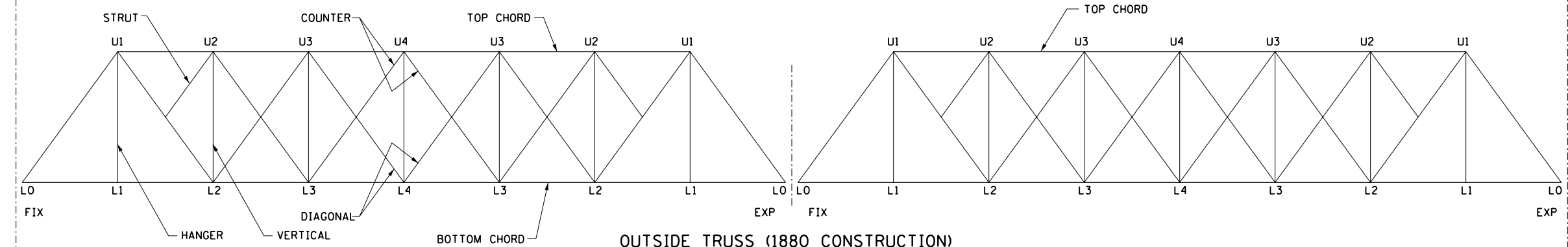

OUTSIDE TRUSS (1880 CONSTRUCTION)

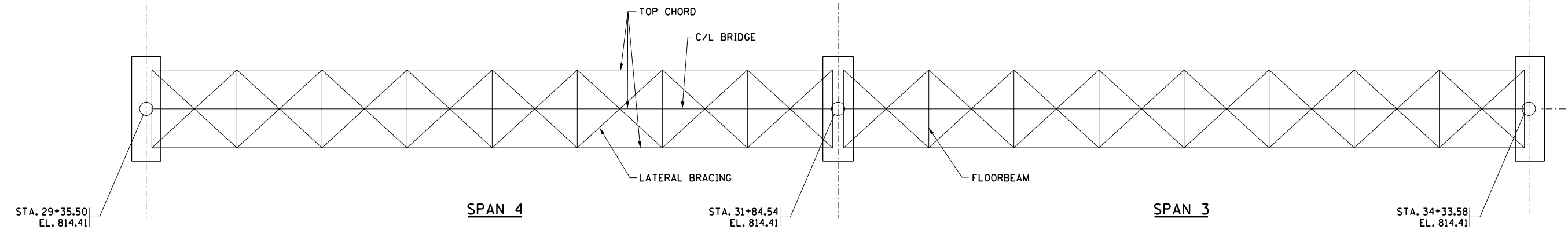

PLAN AT BOTTOM CHORDS

MEMBER IDENTIFICATION

BRIDGE NUMBER 94246 DINKYTOWN BIKEWAY CONNECTION
OVER THE MISSISSIPPI RIVER AT THE UNIVERSITY OF MINNESOTA IN MINNEAPOLIS

FIGURE NO.
4

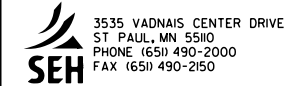

10:23:12 AM

3/12/2009

S:\WORK\WIP\15-105066\15-dsgn\1-cadd\Structural\Report\cbr94246_sh5.dgn

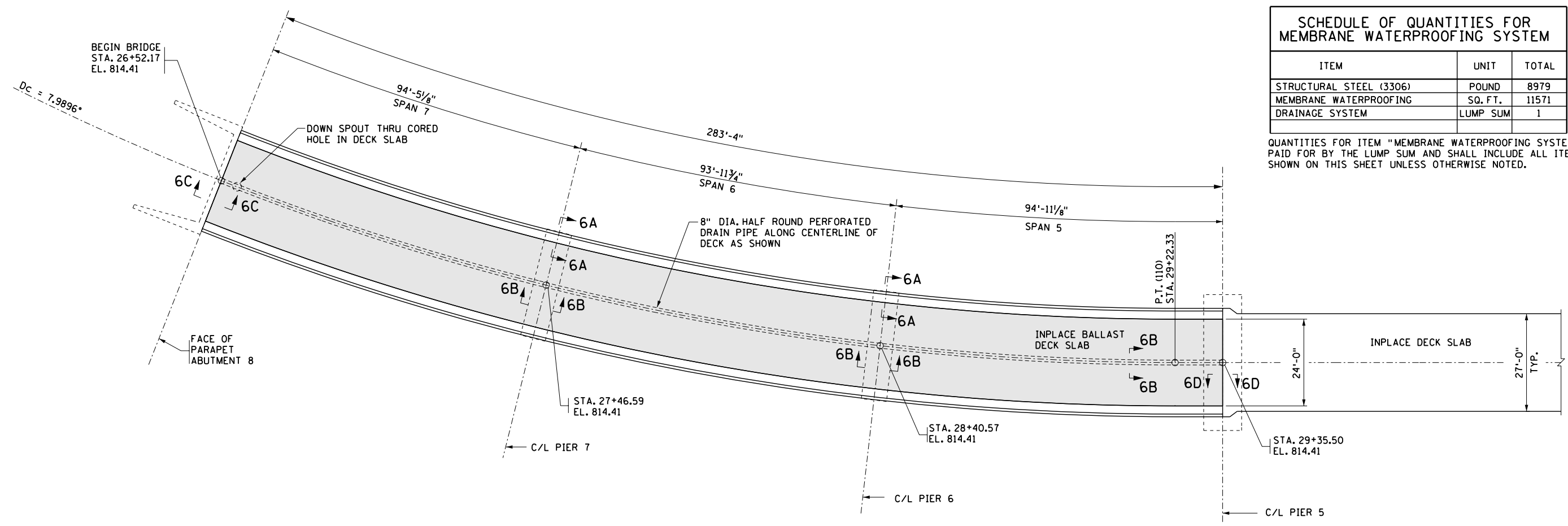

SCHEDULE OF QUANTITIES FOR MEMBRANE WATERPROOFING SYSTEM		
ITEM	UNIT	TOTAL
STRUCTURAL STEEL (3306)	POUND	8979
MEMBRANE WATERPROOFING	SQ. FT.	11571
DRAINAGE SYSTEM	LUMP SUM	1

QUANTITIES FOR ITEM "MEMBRANE WATERPROOFING SYSTEM" PAID FOR BY THE LUMP SUM AND SHALL INCLUDE ALL ITEMS SHOWN ON THIS SHEET UNLESS OTHERWISE NOTED.

SPANS 5, 6 AND 7

AREA OF NEW WATERPROOFING MEMBRANE SHOWN SHADED.

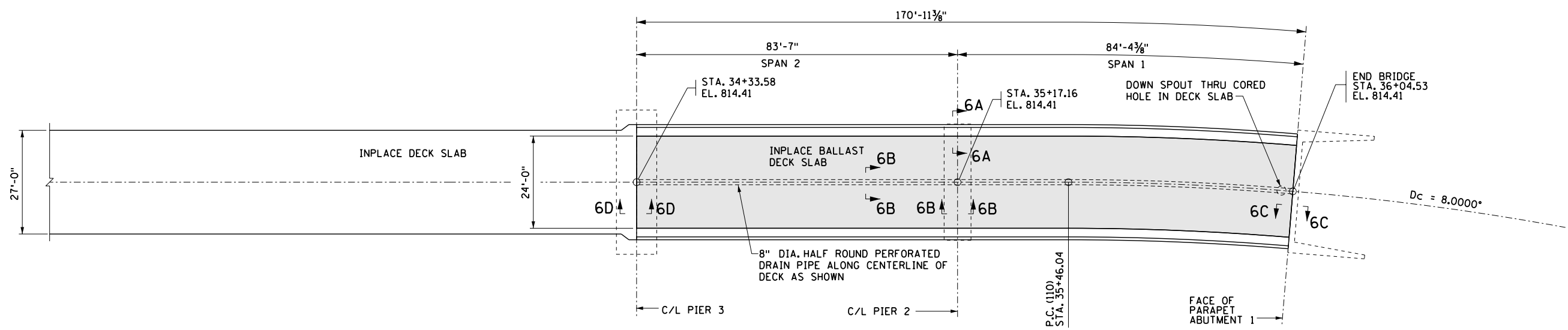

SPANS 1 AND 2

WATERPROOFING LAYOUT PLAN

BRIDGE NUMBER 94246 DINKYTOWN BIKEWAY CONNECTION
OVER THE MISSISSIPPI RIVER AT THE UNIVERSITY OF MINNESOTA IN MINNEAPOLIS

FIGURE NO.
5

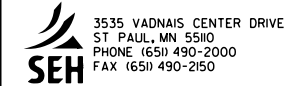

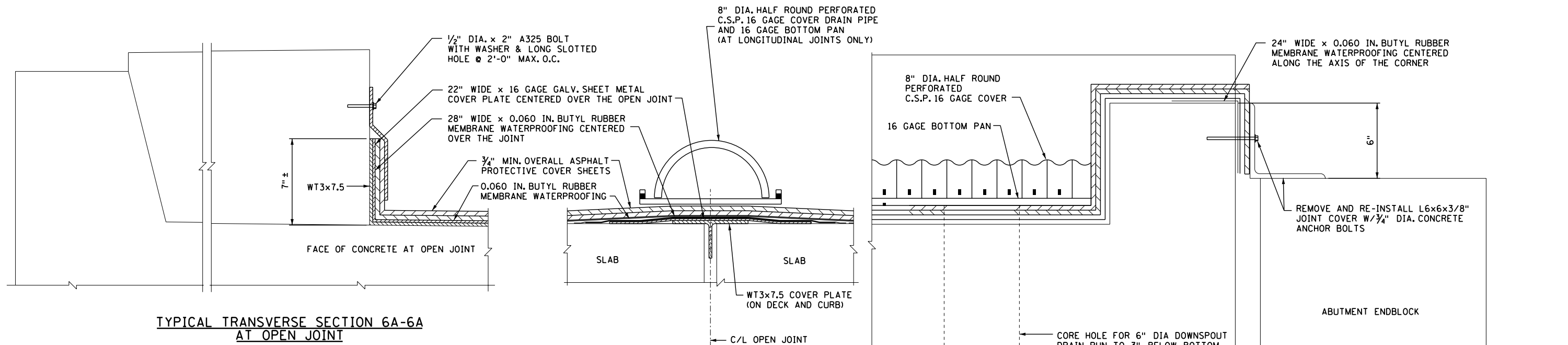

TYPICAL TRANSVERSE SECTION 6A-6A AT OPEN JOINT

TYPICAL SECTION 6B-6B AT DECK JOINTS

TYPICAL LONGITUDINAL SECTION 6C-6C AT END OF ABUTMENT BACKWALL

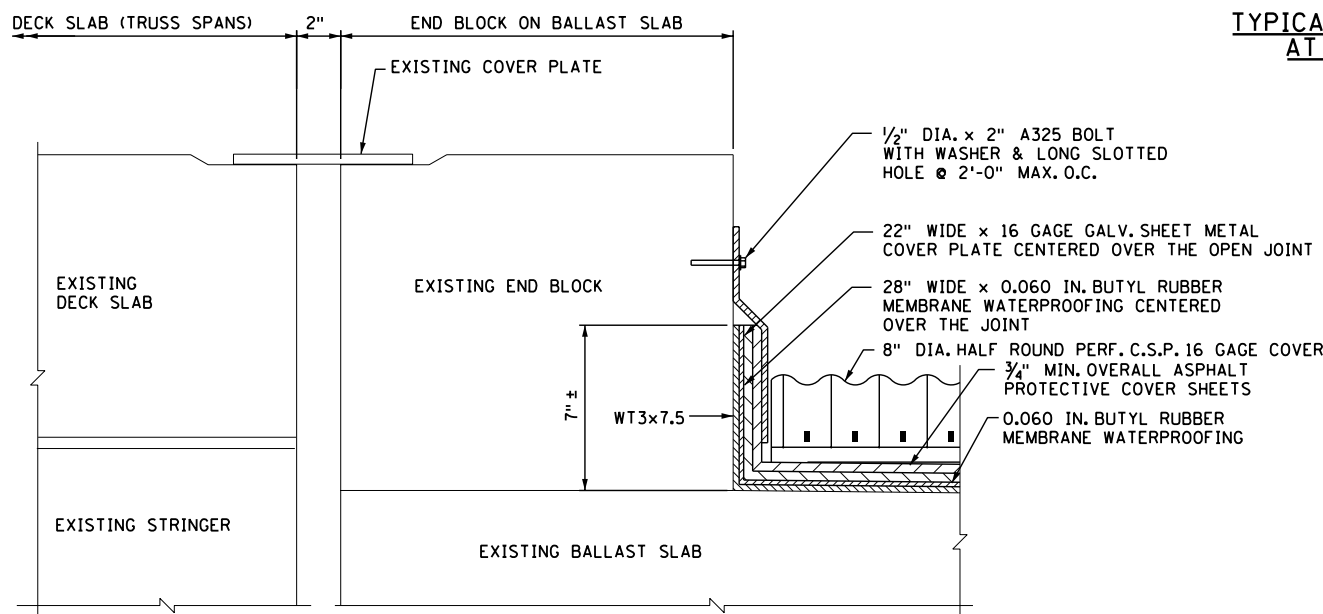

TYPICAL LONGITUDINAL SECTION 6D-6D AT PIER 3 AND PIER 5

DECK WATERPROOFING FOR CONCRETE DECKS:

DECK WATERPROOFING SHALL BE APPLIED TO THE INSIDE SURFACES OF CURBS AND TOP SURFACE OF THE SLABS. WATERPROOFING MEMBRANE TO BE APPLIED ON TOP OF A PRIMER COMPATIBLE WITH THE SUBSTRATE AS RECOMMENDED BY THE MANUFACTURER. THE MEMBRANE SHALL BE 100% SOLVENT FREE REACTIVE, COLD LIQUID, SPRAY APPLIED SEAMLESS ELASTOMERIC MEMBRANE IN ACCORDANCE WITH A.R.E.M.A. CHAPTER 29, CLAUSE 2.3.10.

MEMBRANE PROTECTION (ASPHALT BOARDS) SHALL BE INSTALLED OVER THE WATERPROOFING IN ACCORDANCE WITH A.R.E.M.A. CHAPTER 29, CLAUSE 2.4.2.

THE CONCRETE SHALL HAVE CURED A MINIMUM OF SEVEN DAYS IN ACCORDANCE WITH ACI 308 AND SHALL BE FREE OF MOISTURE, OIL, GREASE, LAITANCE, CURING COMPOUNDS, LOOSE PARTICLES, RUST OR OTHER DELETERIOUS SUBSTANCES. IF REQUIRED THE CONCRETE SURFACE SHALL BE DEGREASED IN ACCORDANCE WITH ASTM D4258. ABRASIVE CLEANING OF THE CONCRETE SURFACE IN ACCORDANCE WITH ASTM D4259 SHALL BE DONE PRIOR TO APPLICATION OF THE PRIMER. SPALLS, VOIDS, BLOWHOLES AND ALL LOCATIONS WHERE SURFACE DETERIORATION EXCEEDS 3/8 INCHES SHALL BE REPAIRED WITH AN APPROVED FAST CURING CONCRETE PATCHING MATERIAL. THE PREPARED CONCRETE SHALL BE SMOOTH WITH A SURFACE PROFILE (PEAK TO VALLEY) NOT EXCEEDING 1/4 INCH. PRIOR TO APPLICATION OF PRIMER THE CONCRETE SURFACE SHALL BE VERIFIED TO BE DRY. FOLLOWING APPLICATION OF THE PRIMER, ELASTOMERIC WATERPROOFING BOND STRENGTH SHALL BE VERIFIED TO BE A MINIMUM OF 100 PSI FOR ACCEPTANCE (OR ACCEPTABLE BY FAILURE OF THE CONCRETE) IN ACCORDANCE WITH ASTM D4541. THE ASTM D4541 TEST TO BE CONDUCTED AT LEAST ONCE FOR EACH 5000 SQ. FT. OF WATERPROOFED AREA.

THE MEMBRANE SHALL BE APPLIED TO OBTAIN A TOTAL ELASTOMERIC MEMBRANE THICKNESS IN ACCORDANCE WITH MANUFACTURER'S RECOMMENDATIONS APPROVED BY THE ENGINEER. THE WET FILM THICKNESS OF THE MEMBRANE SHALL BE CONFIRMED BY TESTING AT LEAST ONCE FOR EVERY 100 SQ. FT. OF WATERPROOFED AREA.

THE WATERPROOFING SYSTEM TO BE APPLIED IN ACCORDANCE WITH THE STRICTER OF A.R.E.M.A. CHAPTER 29, MANUFACTURERS SPECIFICATIONS AND THESE NOTES.

ALL STRUCTURAL STEEL PLATES, BOLTS AND WASHERS SHALL BE GALVANIZED.

DISCONTINUE FLASHING OVER PIERS AND ABUTMENTS.

GALVANIZE STEEL PLATES 0.25" THICKNESS OR LESS ARE INCIDENTAL TO "BUTYL RUBBER MEMBRANE WATERPROOFING".

THREADED CONCRETE INSERTS ARE INCIDENTAL TO "CONCRETE MASONRY".

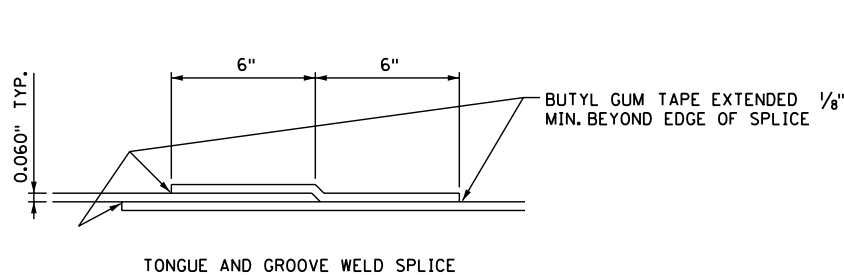

BUTYL RUBBER MEMBRANE WATERPROOFING SPLICE DETAIL

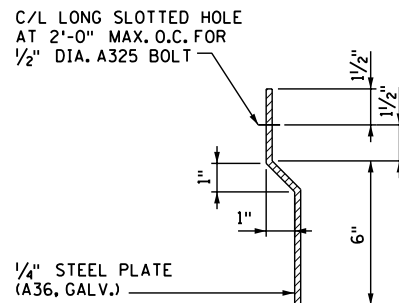

FLASHING DETAIL

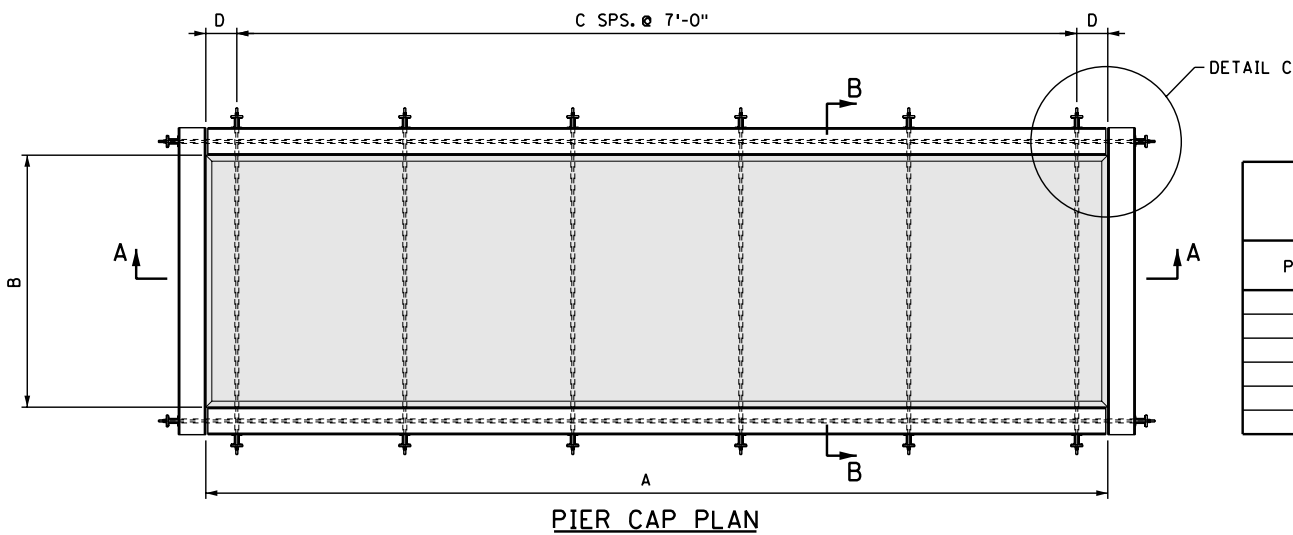

PIER CAP DIMENSIONS				
PIER	DIMENSIONS			D
	A	B	C	
2	30'-3"	7'-0"	4	1'-1/2"
3	37'-7"	10'-6"	5	1'-3/2"
4	37'-7"	11'-0"	5	1'-3/2"
5	37'-7"	10'-6"	5	1'-3/2"
6	30'-3"	7'-0"	4	1'-1/2"
7	30'-3"	7'-0"	4	1'-1/2"

SCHEDULE OF QUANTITIES FOR POST-TENSIONING SYSTEM								
ITEM	UNIT	PIER 2	PIER 3	PIER 4	PIER 5	PIER 6	PIER 7	TOTAL
STRUCTURAL STEEL (3306)	POUND	13269	16679	16837	16679	13269	13269	90000
POST-TENSIONING DUCTS	LIN. FT.	186	246	249	246	186	186	1299
CORE DRILLED HOLES 3" DIA	LIN FT	35	63	66	63	35	35	297
CONCRETE SURFACE REPAIR	LUMP SUM	76	74	76	74	46	60	406

QUANTITIES FOR ITEM "POST-TENSIONING SYSTEM" PAID FOR BY THE SYS.(SYSTEM) AND SHALL INCLUDE ALL ITEMS SHOWN ON THIS SHEET UNLESS OTHERWISE NOTED.

RODS SHALL COMPLY WITH Mn/DOT SPEC. 3313, TYPE I.

SHAPES, PLATES, FLAT BARS AND ANCHORAGES SHALL COMPLY WITH Mn/DOT SPEC. 3306.

GALVANIZE BOLTS, NUTS, WASHERS AND RODS AS PER Mn/DOT SPEC. 3392.
GALVANIZE STRUCTURAL MEMBERS AND ALL MISC OTHER MATERIAL AS PER Mn/DOT SPEC. 3394 AFTER FABRICATION.

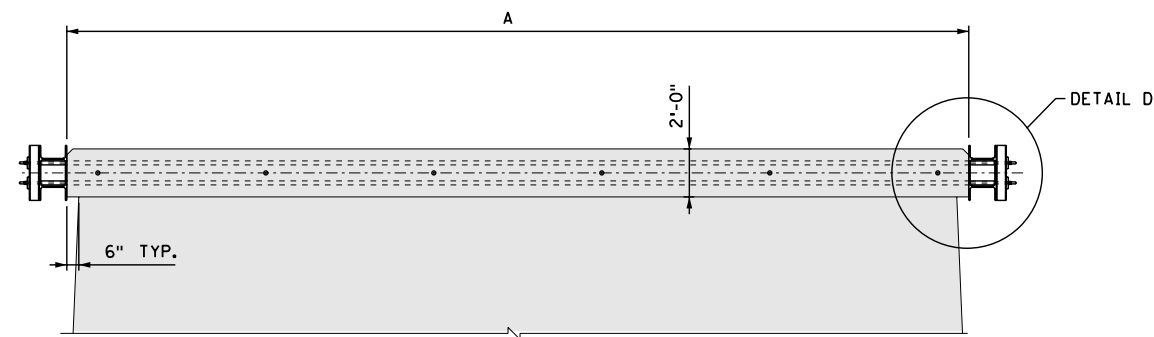

SECTION A-A

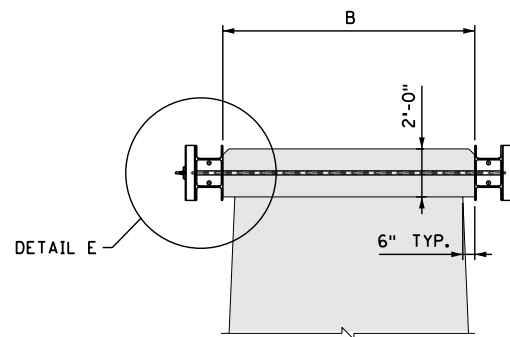

SECTION B-B

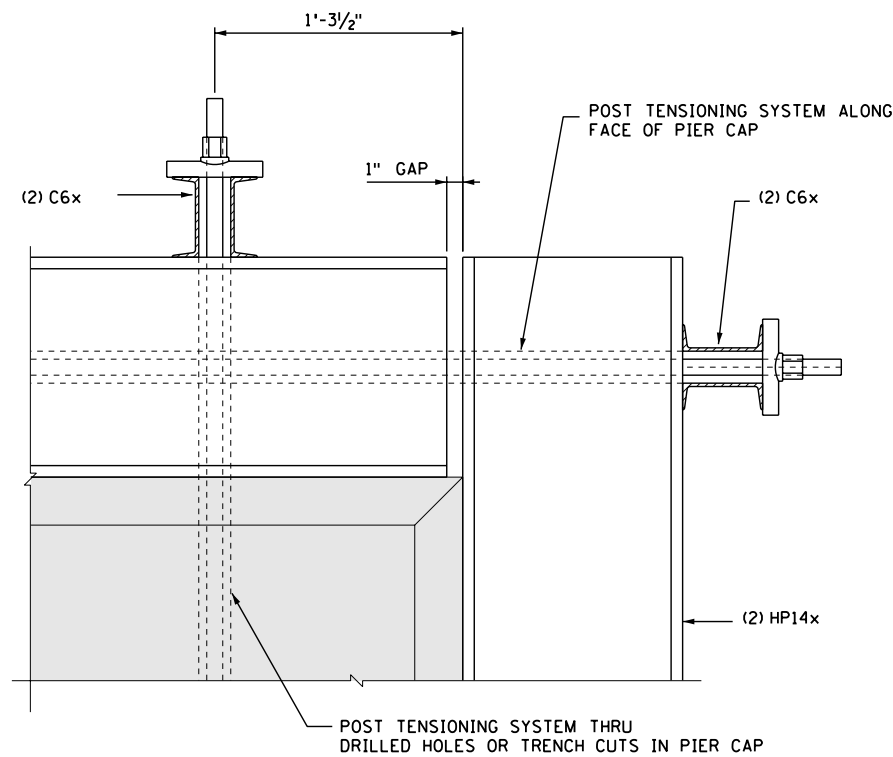

DETAIL C

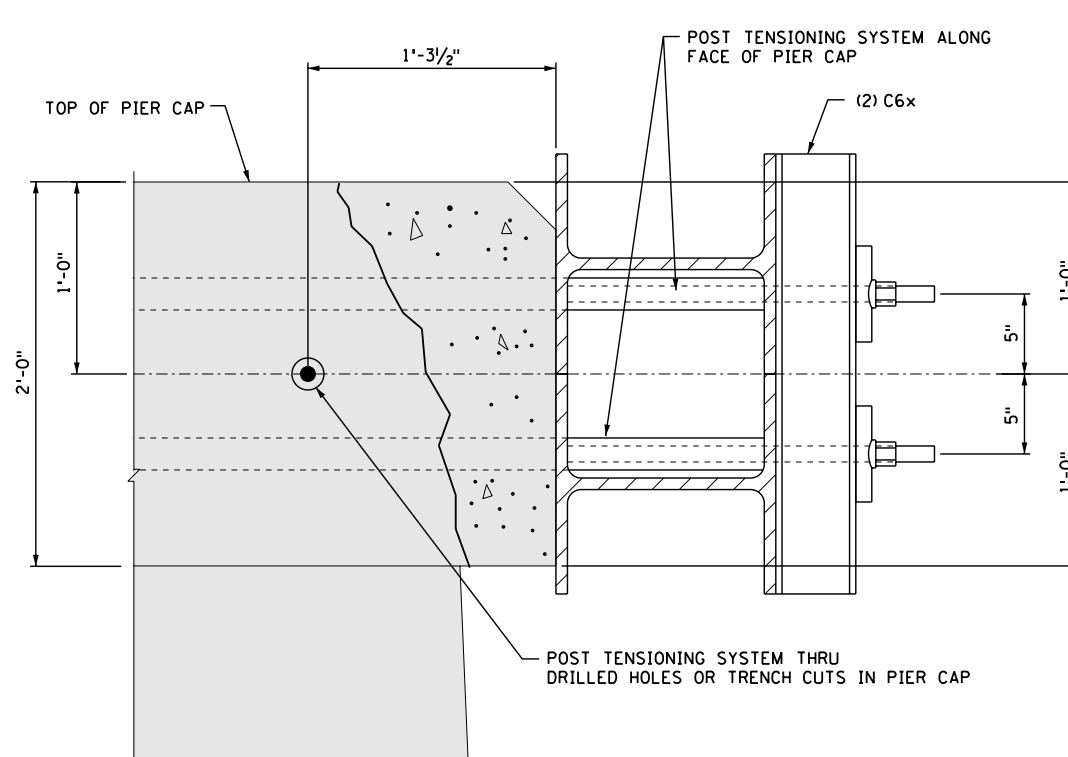

DETAIL D

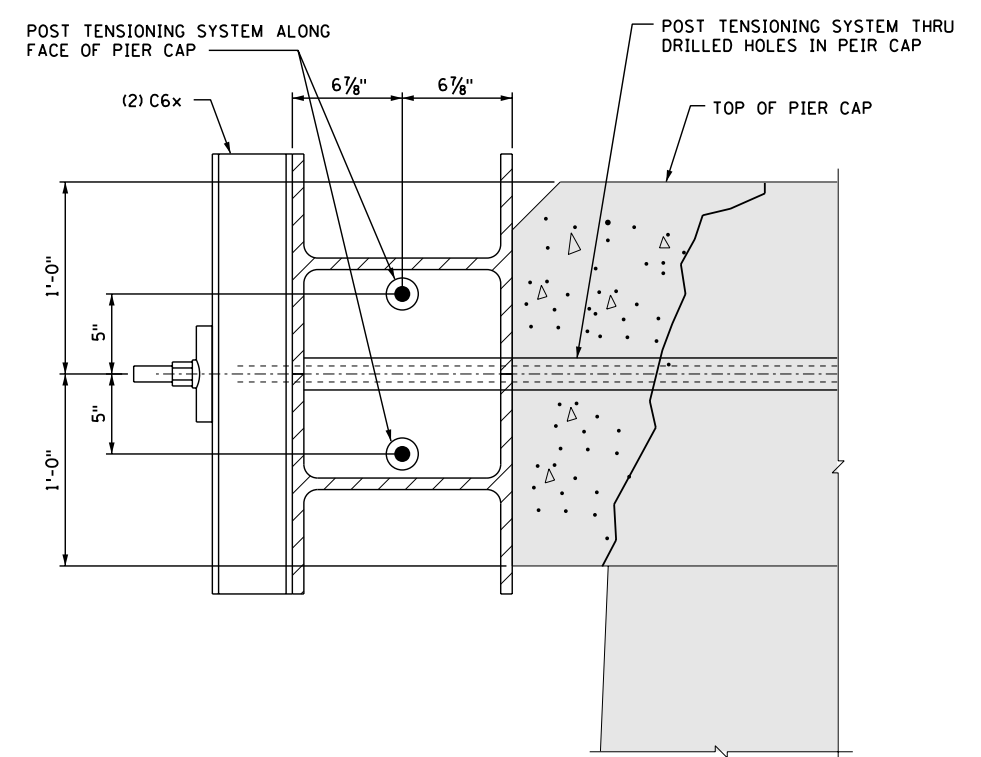

DETAIL E

PIER DETAILS

Appendix A

Photographs from Bridge Condition Inspections



Elevation Photo: Looking South Towards Bridge No. 9



Abutment 1: North Side Bearing



Abutment 1: Bearing



Abutment 1: South Wingwall



Abutment 1: Stem Wall



Abutment 1: Bearing



Abutment 1: North Wingwall

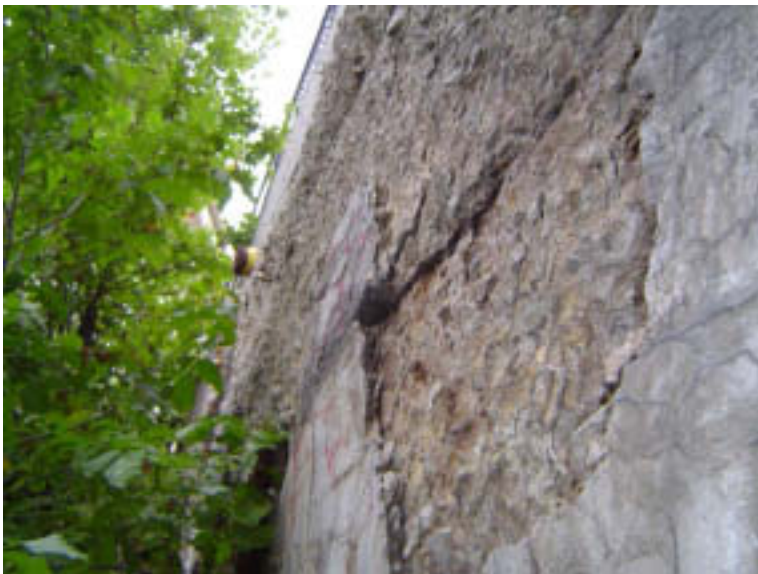

Abutment 1: North Wingwall



Abutment 1: Abutment Seat



Abutment 1: Abutment Seat



Abutment 1: Abutment Seat



Pier 2: Pier Cap



Pier 2: Pier Cap



Pier 2: Pier Cap



Pier 2: Pier Column



Pier 2: Pier Downstream Side



Pier 2



Pier 2: Pier Cap



Pier 2: Pier Cap



Pier 2: Bearings



Pier 2: Bearings



Pier 2: Bearings



Pier 2: Pier Cap



Pier 2: Pier Cap



Pier 2: Pier Cap



Pier 2: Pier Cap



Pier 2: Pier Column Upstream



Pier 2: Pier Cap and Bearings



Pier 2: Pier Cap



Pier 3: Concrete Cap and Bearing



Pier 3: Concrete Cap and Bearing



Pier 3: Bearing



Pier 3: Bearing and Concrete Cap



Pier 3: Concrete Cap



Pier 3: Concrete Pier



Pier 3: Steel Cap and Girder Span Bearing



Pier 3: Steel Cap and Girder Span Bearing



Pier 3: Steel Cap and Girder Span Bearing



Pier 3: Steel Cap and Girder Span Bearing



Pier 3: Steel Cap and Girder Span Bearing



Pier 3: Steel Cap and Girder Span Bearing



Pier 3: Concrete Cap and Bearing



Pier 3: Concrete Cap



Pier 3: Lower Concrete Bearing



Pier 3: Lower Concrete Bearing



Pier 3: Lower Concrete Cap



Pier 3: Lower Concrete Cap



Pier 3: Lower Concrete Bearing



Pier 3: Lower Concrete Cap



Pier 3: Lower Concrete Cap



Pier 3: Lower Concrete Cap



Pier 4: Center Bearing



Pier 4: Side Bearing



Pier 4: Center Bearing



Pier 4: Center Bearing



Pier 4: Side Bearing



Pier 4



Pier 4



Pier 4



Pier 4



Pier 4: Center Bearing



Pier 4: Bearing



Pier 4: Cap and Column Wall



Pier 4: Bearing



Pier 4: Pier Cap



Pier 5: Concrete Cap Edge and Bearing



Pier 5: Steel Cap and Bearing



Pier 5: Steel Cap



Pier 5: Expansion Joint



Pier 5: Truss Span Bearing



Pier 5: Steel Cap Calcium Carbonate Built Up



Pier 5: Steel Cap Calcium Carbonate Built Up



Pier 5: Steel Cap Bearing



Pier 5: Expansion Joint



Pier 5



Pier 5



Pier 5: Steel Column



Pier 5: Concrete Cap



Pier 5: Concrete Cap



Pier 5: Concrete Cap



Pier 5: Concrete Cap and Bearing



Pier 5: Concrete Cap Edge



Pier 6: Pier Cap and Bearing



Pier 6: Pier Cap



Pier 6: Pier Cap Deterioration



Pier 6: Pier Cap



Pier 6: Pier Cap



Pier 6: Bearing and Calcium Carbonate



Pier 6: Exposed Reinforcement Below Cap



Pier 6: Exposed Reinforcement Below Cap



Pier 6: Bearing and Calcium Carbonate



Pier 6



Pier 6: Pier Cap and Bearing



Pier 6: Drainage on to Pier from Deck



Pier 7: Pier Cap



Pier 7: Pier Cap



Pier 7: Bearing Calcium Carbonate



Pier 7: Bearing Calcium Carbonate



Pier 7: Bearing



Pier 7: Pier Cap Deterioration



Pier 7: Pier Cap Deterioration



Pier 7: Drainage on Cap from Deck



Pier 7: Pier Cap Deterioration



Pier 7: Drainage on Cap from Deck



Pier 7: Pier Cap Deterioration



Pier 7: Pier Cap Deterioration



Pier 7: Pier Cap Deterioration



Pier 7



Abutment 8



Abutment 8



Abutment 8



Abutment 8



Span 1: Exposed Reinforcement



Span 1: Center of Deck



Span 1: Soffit Crack



Span 1: Soffit Exposed Reinforcement



Span 1: Soffit Exposed Reinforcement



Span 1: Soffit Exposed Reinforcement



Span 2: Exposed Reinforcement



Span 2: Under Side Center of Deck



Span 2: Soffit



Span 2: Exposed Reinforcement



Span 2: Expansion Joint



Span 2: Soffit



Span 2: Staining from Drainage



Span 3: Bottom Chords



Span 3: Upper Chords



Span 3: Bottom Chords



Span 3: Top Chords and Vertical Members



Span 3: Center Truss



Span 3: Outside Truss Bracing



Span 3: Center Truss L1



Span 3: Outside Truss L1



Span 3: Upper Chord



Span 3: Center Truss Lower Connection



Span 3: Upper Chord and Floor Beam



Span 3: Vertical Members



Span 3: Upper Chords



Span 3: Lower Chords



Span 3: Center Truss Lower Connection



Span 3: Upper Chords

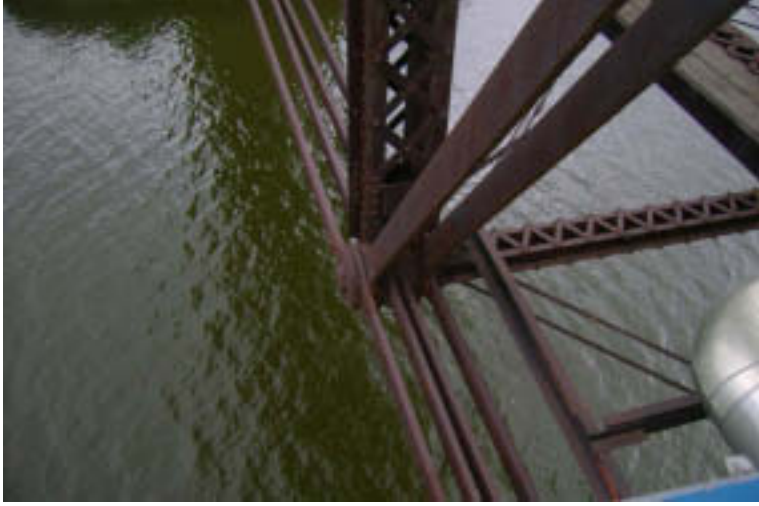

Span 3: Lower Chords



Span 3: Lower Chords



Span 3: Upper Chords Members



Pier 3: Upper Bearing



Pier 3: Upper Steel Cap



Pier 3: Upper Steel Cap



Pier 3: Lower Concrete Cap



Pier 3: Steel Column Bracing



Pier 3: Steel Cap



Span 3: Upper Truss Members



Span 3: Upper Truss Connections



Span 3: Center Truss



Span 3: Upper Chords



Span 3: Transverse Bracing



Span 4: Upper Chord



Span 4: Upper Chords: Floor Beams and Stringers



Span 4: Outside Truss Bracing



Span 4: Bottom Chord Connection



Span 4: Upper Chord Connection



Span 4: Outside Truss Bracing



Span 4: Vertical Members



Span 4: Lower Chord Connection



Span 4: Diagonal Members



Span 4: Lower Chord Connection



Span 4: Center Truss Connection



Span 4: Lower Chord Connection



Span 4: Deck Crack and Bleaching



Span 4: Diagonal Members



Span 4: Lower Chord Transverse Bracing



Span 4: Upper Chord: Floor Beams and Stringers



Span 4: Upper Chord: Floor Beams and Stringers



Span 4: Vertical Members



Span 4: Center Truss



Span 4: Center Truss



Span 4: Center Truss



Span 4: Center Truss: Floor Beams and Stringers



Span 4: Lower Chord Connection



Span 4: Lower Chords



Span 4: Bracing



Span 4: Vertical Members



Span 4: Lower Chord Connection



Span 4: Center Truss Lower Connection



Span 4: Center Truss Upper Connection



Span 4: Center Truss



Span 5: Center Line of Deck



Span 5: Center Line of Deck



Span 5: Expose Reinforcement



Span 5: Calcium Carbonate Dripping



Span 5: Calcium Carbonate Build Up



Span 5: Calcium Carbonate Dripping from Deck to Girders



Span 5: Deck and Girder at the Expansion



Span 5: Deck at Expansion Joint



Span 5: Calcium Carbonate Built



Span 5: Calcium Carbonate Built



Span 6: Deck Expose Reinforcement



Span 6: Center Line of Deck



Span 6: Drainage Cracks



Span 6: Deck Expose Reinforcement



Span 6: Deck Crack



Span 6: Deck Expose Reinforcement



Span 7: Deck Weathering



Span 7: Deck Exposed Reinforcement



Span 7: Center of the Deck



Span 7: Deck Spawling



Span 7: Deck



Span 7: Calcium Carbonate Built Up



Span 7: Joint near Pier 7



Span 7: Calcium Carbonate Built Up



Span 7: Calcium Carbonate Built Up



Span 7: Expose Reinforcement



Span 7: Expose Reinforcement



Historic Marker

Appendix B

Hazardous Material Assessment

CORROSION CONTROL CONSULTANTS & LABS, INC. a GPI company

ANALYTICAL LABORATORY REPORT

Monday, October 6, 2008

Page 1 of 1

CUSTOMER: SEH, Inc.
3535 Vadnais Center Dr
St. Paul, MN 55110

DATE RECEIVED: Wednesday, October 1, 2008
PO/PROJECT #: 105066
SUBMITTAL #: 2008-10-01-012

LAB NUMBER: AA40703

Sampled By: Gaylen Perkuhn
Job Location: Minneapolis Bridge No. 9 over Mississippi River
Sample Identification: 1. North Fascia Beam, Exterior Face 2nd Approach Span From East Abut.

Date Sampled: Monday, September 22, 2008
Sample Description: Paint Chips

Preparation Method: EPA 600/R-93/200M-P (Total Metals in Paint Chips, Sonication)
Analysis Method: EPA 6010B (ICP-AES Method for Determination of Metals)
Date Analyzed: Monday, October 6, 2008

ELEMENT	RESULT (by weight)	REPORTING LIMIT (RL)
Cadmium	< RL	0.00075 %
Chromium	0.085 %	0.0013 %
Lead	9.0 %	0.0050 %

LAB NUMBER: AA40704

Sampled By: Gaylen Perkuhn
Job Location: Minneapolis Bridge No. 9 over Mississippi River
Sample Identification: 2. South Fascia Beam, Exterior Face 1st Approach Span From West Abut.

Date Sampled: Tuesday, September 23, 2008
Sample Description: Paint Chips

Preparation Method: EPA 600/R-93/200M-P (Total Metals in Paint Chips, Sonication)
Analysis Method: EPA 6010B (ICP-AES Method for Determination of Metals)
Date Analyzed: Monday, October 6, 2008

ELEMENT	RESULT (by weight)	REPORTING LIMIT (RL)
Cadmium	< RL	0.00075 %
Chromium	0.23 %	0.0013 %
Lead	15 %	0.0050 %

Unless otherwise noted, the condition of each sample was acceptable upon receipt, all laboratory quality control requirements were met, and sample results have not been adjusted based on field blank or other analytical blank results.

Tests Reviewed By: Michael J. Swiech, QA/QC Manager *Michael Swiech*

Corrosion Control Consultants & Labs, Inc. is ATHA accredited in the Environmental Lead Program for paint, soil, dust wipes, and air; and in the Industrial Hygiene Program for metals in air.

This report shall not be reproduced except in full, without written approval of CCC&L.
Individual sample results relate only to the sample as received by the laboratory.

Appendix C

Mn/DOT Structure Inventory and Bridge Inspection Reports

MINNESOTA DEPARTMENT OF TRANSPORTATION
 BRIDGE MANAGEMENT UNIT
 BRIDGE ROSTER
 for CITY OF MINNEAPOLIS (Sorted by Bridge Number)

02/13/2009

PAGE: 11

BRDG NBR	AGCY BRDG NBR	FACILITY CARRIED	REFERENCE POINT	MAIN SPAN DESCRIPTION	D ESSHU CUAL KPBNU	CC VECHP AOL2P LMROR	EGU A	FHWA STATUS	DEF STAT	SUFF RATE
93965	4871	SKYWAY / 9TH ST S	000+00.540	STEEL HIGH TRUSS	8 8 8 N N	N N 7 N N		OPEN	ADEQ	
94168	9958.1	PEDESTRIAN / BASSETT CREEK		STEEL LOW TRUSS	7 8 8 8 N	N N N 8 N		OPEN	ADEQ	
94169	7875	SKYWAY / NICOLLET MALL		STEEL HIGH TRUSS	8 8 8 N N	N N 9 N N		OPEN	ADEQ	
94170	4876	SKYWAY / GRANT ST	000+00.024	STEEL HIGH TRUSS	8 8 8 N N	N N 4 N N		OPEN	ADEQ	
94172	4874	SKYWAY / 8TH ST S	000+00.518	STEEL HIGH TRUSS	8 8 8 N N	N N 9 N N		OPEN	ADEQ	
94173	9981	PEDESTRIAN / LAKE NOKOMIS OUTLET		TIMB BEAM SPAN	7 7 6 8 N	N N N 8 N		OPEN	ADEQ	
94188	7877	SKYWAY / 23RD AV S	000+00.041	STEEL HIGH TRUSS	8 8 8 N N	N N 9 N N		OPEN	ADEQ	
94209	4878	SKYWAY (2ND LEVEL) / 6TH ST S	000+00.510	STEEL HIGH TRUSS	8 8 8 N N	N N 9 N N		OPEN	ADEQ	
94210	4879	SKYWAY(4TH LEVEL) / 6TH ST S	000+00.511	STEEL HIGH TRUSS	8 8 8 N N	N N 9 N N		OPEN	ADEQ	
94211	4880	SKYWAY / LASALLE AVE	001+00.000	STEEL HIGH TRUSS	8 8 8 N N	N N 7 N N		OPEN	ADEQ	
94212	4881	SKYWAY / MARQUETTE AVE	000+00.025	STEEL HIGH TRUSS	8 8 8 N N	N N 9 N N		OPEN	ADEQ	
94213	4882	SKYWAY / 11TH ST S	000+00.803	STEEL HIGH TRUSS	8 8 8 N N	N N 6 N N		OPEN	ADEQ	
94214	4883.1	SKYWAY / 12TH ST S	000+00.120	STEEL HIGH TRUSS	8 8 8 N N	N N 5 N N		OPEN	ADEQ	
94215	4884	SKYWAY / 6TH ST S	000+00.348	STEEL HIGH TRUSS	8 8 8 N N	N N 9 N N		OPEN	ADEQ	
94216	4887	SKYWAY / 2ND AVE S	000+00.610	STEEL HIGH TRUSS	8 8 8 N N	N N 7 N N		OPEN	ADEQ	
94217	7885	SKYWAY / 13TH ST S	000+00.120	STEEL HIGH TRUSS	8 8 8 N N	N N 9 N N		OPEN	ADEQ	
94218	7886	SKYWAY / NICOLLET MALL	000+00.072	STEEL HIGH TRUSS	8 8 8 N N	N N 4 N N		OPEN	ADEQ	
94229	4891	SKYWAY / 2ND AV S	000+00.295	STEEL HIGH TRUSS	7 8 8 N N	N N 8 N N		OPEN	ADEQ	
94230	4892	SKYWAY / 10TH ST	000+00.571	STEEL HIGH TRUSS	8 8 8 N N	N N 6 N N		OPEN	ADEQ	
94231	4893.2	SKYWAY / 2ND AVE S	000+00.220	STEEL HIGH TRUSS	8 8 8 N N	N N 5 N N		OPEN	ADEQ	
94242	4894	SKYWAY / 3RD ST S	000+00.120	STEEL HIGH TRUSS	8 8 8 N N	N N N N N		OPEN	ADEQ	
94243	7895	SKYWAY / 3RD-4TH ST ALLEY		STEEL HIGH TRUSS	8 8 8 N N	N N 3 N N		OPEN	F.O.	
94246	7214	BR#9 PED (ABAN RR) / MISS RIVER & W RIVER RD		STEEL DECK TRUSS	8 6 4 7 N	N N 9 8 N		OPEN	S.D.	
94247	9538	WEST RIVER PARKWAY / BASSETT CREEK		MASONRY ARCH	N 6 6 8 N	5 N N 5 N		OPEN	ADEQ	82.6
94253	9982	PEDESTRIAN / BASSETT CREEK		STEEL LOW TRUSS	6 6 8 8 N	N N N 9 N		OPEN	ADEQ	
94254	7555	4TH AVE N / BASSETT CREEK	000+00.250	CONC ARCH	N 7 7 8 N	9 N N 8 8		OPEN	ADEQ	100.0
94255	7556	5TH AVE N / BASSETT CREEK	000+00.100	CONC BOX CULV	N N N 8 6	6 N N 8 8		OPEN	ADEQ	100.0

7/22/2008

CITY OF MINNEAPOLIS Fracture Critical, Underwater, and Pinned Assembly Inspection Report

Br #	Facility Carried	Feature Crossed	Location	Fracture Critical	Underwater	Pinned Assembly	Bridge Status
2796	MSAS 328(10TH)	MISS R; BNSF & STS	0.3 MI N OF WASH AVE		Y - 60 - 08/2007		OPEN
27549	MSAS 262(42nd AVE)	Mississippi River & RR	0.2 MI E OF LYNDAL AVE		Y - 60 - 08/2007	Y - 60 - 08/2007	OPEN
27611	197(PLYMOUTH AVE)	MISSISSIPPI RIVER	0.4 MI E OF WASH. AVE		Y - 60 - 08/2007		OPEN
27687	MUN 605(1ST ST)	CNW RY (ABANDONED)	0.1 MI SE OF 3RD AVE S	Y - 24 - 10/2007			OPEN
90664	97 (ST ANTHONY PK)	BNSF & CP RAILROAD	0.2 MI W OF UNIVERSITY A	Y - 24 - 11/2007			OPEN
94246	PED(ABAN RR)	MISS R & W RIVER RD	PED. BRIDGE SOUTH OF CED		Y - 60 - 08/2007		OPEN
L5733	CP RAIL	W RIVER RD & E RIVER RD	0.9 MI SE OF FRANKLIN AV		Y - 60 - 10/2007		OPEN
L8898	(4 AVE N)	BNSF RR(ABAN)	BTWN 1ST ST & 2ND ST N	Y - 24 - 01/1901			CLOSED

8 Records returned

NOTE: Data shown includes inspection requirement (Y/N), inspection frequency (months), and date of last inspection.

Mn/DOT Structure Inventory Report

Bridge ID: 94246 BR#9 PED (ABAN RR) over MISS RIVER & W RIVER RD

Date: 02/13/2009

+ GENERAL +	+ ROADWAY +	+ INSPECTION +
Agency Br. No. 7214	Bridge Match ID (TIS) 1	Deficient Status S.D.
District METRO Maint. Area	Roadway O/U Key 2-UNDER	Sufficiency Rating
County 27 - HENNEPIN	Route Sys/Nbr MUN	Last Inspection Date 09-22-2008
City MINNEAPOLIS	Roadway Name or Description MISS RIVER & W RIVER RD	Inspection Frequency 12
Township	Roadway Function MAINLINE	Inspector Name MINNEAPOLIS
Desc. Loc. PED. BRIDGE SOUTH OF CE	Roadway Type 2 WAY TRAF	Structure A-OPEN
Sect., Twp., Range 24 - 029N - 24W	Control Section (TH Only)	+ CONDITION CODES +
Latitude 44d 58m 42.00s	Ref. Point (TH Only)	Deck 8
Longitude 93d 14m 24.00s	Date Opened to Traffic 06-01-2000	Superstructure 6
Custodian CITY	Detour Length 1 mi.	Substructure 4
Owner CITY	Lanes 2 Lanes UNDER Bridge	Channel 7
Inspection By CITY OF MINNEAPOLIS	ADT (YEAR) 0 (1995)	Culvert N
BMU Agreement	HCA DT	+ APPRAISAL RATINGS +
Year Built 1922	Functional Class. URBAN LOCAL	Structure Evaluation N
Year Fed Rehab	+ RDWY DIMENSIONS +	Deck Geometry N
Year Remodeled 1999	If Divided NB-EB SB-WB	Underclearances 9
Temp	Roadway Width 24.0 ft	Waterway Adequacy 8
Plan Avail. NO PLAN	Vertical Clearance 18.0 ft	Approach Alignment N
+ STRUCTURE +	Max. Vert. Clear. 18.0 ft	+ SAFETY FEATURES +
Service On PED-BICYCLE	Horizontal Clear. 24.0 ft	Bridge Railing 0-SUBSTANDARD
Service Under HWY;STREAM	Lateral Clr. - L/Rt 18.0 ft	GR Transition UNKN
Main Span Type STEEL DECK TRUSS	Appr. Surface Width 28.0 ft	Appr. Guardrail UNKN
Main Span Detail PRATT	Roadway Width 24.0 ft	GR Termini UNKN
Appr. Span Type STEEL DECK GIRJ	Median Width	+ IN DEPTH INSP. +
Appr. Span Detail	+ MISC. BRIDGE DATA +	Frac. Critical
Skew	Structure Flared NO	Underwater Y 60 mo 08/2007
Culvert Type	Parallel Structure NONE	Pinned Asbly.
Barrel Length	Field Conn. ID PINNED	Spec. Feat.
Number of Spans	Cantilever ID	+ WATERWAY +
MAIN: 2 APPR: 5 TOTAL: 7	Foundations	Drainage Area
Main Span Length 249.0 ft	Abut. CONC - UNKN	Waterway Opening 99999 sq ft
Structure Length 952.0 ft	Pier CONC - UNKN	Navigation Control PERM'T REQD
Deck Width 28.5 ft	On - Off System NO	Pier Protection NOT REQUIRED
Deck Material C-I-P CONCRETE	+ PAINT +	Nav. Vert./Horz. Clr. 38 ft 232.0 ft
Wear Surf Type MONOLITHIC CONC	Year Painted 2000 Pct. Unsound 85 %	Nav. Vert. Lift Bridge Clear.
Wear Surf Install Year	Painted Area	MN Scour Code K-LIMITED RISK
Wear Course/Fill Depth	Primer Type 3309-INORGANIC ZINC	Scour Evaluation Year 1997
Deck Membrane NONE	Finish Type URETHANE	+ CAPACITY RATINGS +
Deck Rebars EPOXY COATED REBAR	+ BRIDGE SIGNS +	Design Load RR
Deck Rebars Install Year	Posted Load NOT REQUIRED	Operating Rating
Structure Area 27,055 sq ft	Traffic NOT REQUIRED	Inventory Rating
Roadway Area 23,734 sq ft	Horizontal NOT REQUIRED	Posting
Sidewalk Width - L/R	Vertical NOT APPLICABLE	Rating Date 01-07-1999
Curb Height - L/R		Mn/DOT Permit Codes
Rail Codes - L/R 40 40		A: N B: N C: N

Mn/DOT BRIDGE INSPECTION REPORT

Inspector: MINNEAPOLIS

BRIDGE 94246 BR#9 PED (ABAN RR) OVER MISS RIVER & W RIVER RD INSP. DATE: 09-22-2008

County: HENNEPIN	Location: PED. BRIDGE SOUTH OF CED	Length: 952.0 ft
City: MINNEAPOLIS	Route: MUN Ref. Pl.:	Deck Width: 28.5 ft
Township:	Control Section: Maint. Area:	Rdwy. Area / Pct. Unsnd: 23,734 sq ft
Section: 24 Township: 029N Range: 24W	Local Agency Bridge Nbr: 7214	Paint Area/ Pct. Unsnd: 85 %
Span Type: STEEL DECK TRUSS		Culvert: N/A
NBF Deck: 8 Super: 6 Sub: 4 Chan: 7 Culv: N	Open, Posted, Closed: OPEN	
Appraisal Ratings - Approach: N Waterway: 8	MN Scour Code: K-LIMITED RISK	Def Stat: S.D. Suff. Rate: UNKN
Required Bridge Signs - Load Posting: NOT REQUIRED	Traffic: NOT REQUIRED	
Horizontal: NOT REQUIRED	Vertical: NOT APPLICABLE	

STRUCTURE UNIT: 0

ELEM NBR	ELEMENT NAME	ENV	INSP. DATE	QUANTITY	QTY CS 1	QTY CS 2	QTY CS 3	QTY CS 4	QTY CS 5
26	TOP OF CONC DECK-EPX	2	09-22-2008 09-11-2007	23,734 SF 27,050 SF	23,734 27,050	0 0	0 0	0 0	0 0
Notes: 26. THERE IS SOME FINE SIZE TRANSVERSE AND LONGITUDINAL CRACKS. SOME GRAFFITI.									
300	STRIP SEAL JOINT	2	09-22-2008 09-11-2007	89 LF 89 LF	89 89	0 0	0 0	N/A N/A	N/A N/A
Notes: 300. FULL OF SAND. MINOR SPALL ON NORTH SIDE BY COVER PLATE.									
301	POURED DECK JOINT	2	09-22-2008 09-11-2007	325 LF 325 LF	325 325	0 0	0 0	N/A N/A	N/A N/A
Notes: 301. MINOR LOSS OF ADHESION WITH MOISTURE LEAKING THROUGHOUT.									
320	CONC APPR SLAB-BITOL	2	09-22-2008 09-11-2007	2 EA 2 EA	2 2	0 0	0 0	0 0	N/A N/A
Notes: 320. ASPHALT OVERLAY HAS ONE MED. SIZE TRANSVERSE CRACK AT PIER EAST END AND ONE LONGITUDINAL AND MANY TRANSVERSE ON THE WEST. UPSTREAM SIDE OF BRIDGE ORIENTS TO THE NORTH AND TO BRIDGE PLANS. VEGETATION GROWING OUT UNDER RAIL.									
334	METAL RAIL-COATED	2	09-22-2008 09-11-2007	1,896 LF 1,896 LF	1,855 1,896	25 0	16 0	0 0	0 0
Notes: 334. THE PAINT IS STARTING TO OXIDIZE WITH SOME PAINT PEELING AND RUST. 30' HEAVY PAINT PEELING WITH RUST DOWNSTREAM SIDE MIDDLE OF BRIDGE. MANY AREAS OF RAIL ARE PITTING. UPSTREAM N.E. VERTICALS HAS WATER EXPANSION. MINOR ACCIDENT DAMAGE TO BOTTOM RAIL AT EAST SIDE NORTH.									
107	PAINTED STEEL GIRDER	2	09-22-2008 09-11-2007	1,818 LF 1,818 LF	0 0	0 0	1,818 1,818	0 0	0 0
Notes: 107. THERE IS UNIFORM MODERATE TO HEAVY RUST ON ALL OF THE APPROACH GIRDERS.									
113	PAINT STEEL STRINGER	2	09-22-2008 09-11-2007	1,959 LF 1,959 LF	0 0	0 0	1,959 1,959	0 0	0 0
Notes: 113. THERE IS UNIFORM MODERATE TO HEAVY RUST WITH PACK RUST AT MANY OF THE CREVICES. RIVET FLOWERING AND HEAVY PACK RUST ON THE UPPER GUSSET PLATES. THERE ARE FOUR STRINGERS ON THE NORTH TRUSS AND EIGHT STRINGERS ON THE SOUTH TRUSS.									
131	PAINT STL DECK TRUSS	1	09-22-2008 09-11-2007	1,493 LF 1,493 LF	0 0	0 0	1,493 1,493	0 0	0 0
Notes: 131 & 357. THERE IS UNIFORM MODERATE TO HEAVY RUST THROUGHOUT WITH PACKRUST AT MANY OF THE CREVICES.									
151	WEATH STL FLOORBEAM	2	09-22-2008 09-11-2007	449 LF 449 LF	0 0	0 0	449 449	0 0	N/A N/A
Notes: 151. THERE IS UNIFORM MODERATE TO HEAVY RUST THROUGHOUT WITH PACKRUST AT THE CREVICES.									

Mn/DOT BRIDGE INSPECTION REPORT

Inspector: MINNEAPOLIS

BRIDGE 94246 BR#9 PED (ABAN RR) OVER MISS RIVER & W RIVER RD INSP. DATE: 09-22-2008**STRUCTURE UNIT: 0**

ELEM NBR	ELEMENT NAME	ENV	INSP. DATE	QUANTITY	QTY CS 1	QTY CS 2	QTY CS 3	QTY CS 4	QTY CS 5
380	SECONDARY ELEMENTS	1	09-22-2008	1 EA	1	0	0	0	N/A
			09-11-2007	1 EA	1	0	0	0	N/A
Notes: 380. DIAPHRAGMS- HEAVY RUST.									
311	EXPANSION BEARING	2	09-22-2008	26 EA	0	26	0	N/A	N/A
			09-11-2007	26 EA	0	26	0	N/A	N/A
Notes: 311. SOME OF THE BEARING NUTS AND BOLTS ARE MISSING. THERE IS HEAVY PACK RUST AT ALL OF THE BEARINGS FULL OF DEBRIS.									
313	FIXED BEARING	2	09-22-2008	26 EA	0	26	0	N/A	N/A
			09-11-2007	26 EA	0	26	0	N/A	N/A
Notes: 313. SOME OF THE BEARING NUTS AND BOLTS ARE MISSING. THERE IS HEAVY PACK RUST AT ALL OF THE BEARINGS. THERE IS SOME DEBRIS IN THE ROCKER ASSEMBLIES. LOSS OF BEARING WEST SIDE OF PIER 3.									
210	CONCRETE PIER WALL	2	09-22-2008	167 LF	0	142	25	0	N/A
			09-11-2007	167 LF	0	142	25	0	N/A
Notes: 210. THERE ARE MANY CRACKS AND SPALLS WITH RUST STAINS. THE CENTER PIER ALSO HAS AREAS OF EFFLORESCENCE. THERE IS HEAVY GRAFFITI.									
215	CONCRETE ABUTMENT	2	09-22-2008	56 LF	0	30	30	0	N/A
			09-11-2007	56 LF	0	30	30	0	N/A
Notes: 215. THE EAST HAS HEAVY SCALE, SPALLING, MAP CRACKING AND VERTICAL CRACKS. THE N.E SEEMS TO BE SINKING. THE WEST BACKWALL HAS SOME VERTICAL CRACKS THE WEST ABUTMENT HAS ONE SMALL SIZED FULL HEIGHT VERTICAL CRACK. THE WEST ABUTMENT IS FULL OF SAND. WEST HEAVY GRAFFITI.									
234	CONCRETE CAP	2	09-22-2008	167 LF	0	135	30	2	N/A
			09-11-2007	167 LF	0	135	30	2	N/A
Notes: 234. THE WEST ABUTMENT CAP HAS SOME CRACKS. ALL OF THE PIERS HAVE SOME DEBRIS ON THEM. THE EAST ABUTMENT CAP IS MASSIVELY CRACKED AND IS FULL OF DEBRIS. THE PIER CAPS ARE DETERIORATING, SPALLS AND SOME LOSS OF BEARING.									
387	CONCRETE WINGWALL	2	09-22-2008	4 EA	0	2	2	0	N/A
			09-11-2007	4 EA	0	2	2	0	N/A
Notes: 387. THE ABUTMENT SIDEWALLS ON THE EAST HAVE LARGE AREAS OF SCALING, SPALLS AND MAP CRACKING WITH EFFLORESCENCE AND DELAMINATION.									
357	PACK RUST	2	09-22-2008	1 EA	0	1	0	0	N/A
			09-11-2007	1 EA	0	1	0	0	N/A
Notes: 357. PACK RUST AT ELEMENT 131, 151 AND 113.									
358	CONC DECK CRACKING	2	09-22-2008	1 EA	1	0	0	0	N/A
			09-11-2007	1 FA	1	0	0	0	N/A
Notes: 358 THERE IS 515 LIN. FT. OF DECK CRACKING IN 2000.									
359	CONC DECK UNDERSIDE	2	09-22-2008	1 EA	1	0	0	0	0
			09-11-2007	1 EA	1	0	0	0	0
Notes: 359. THE CONCRETE SUBSURFACE ON THE APPROACH ON THE WEST HAS SPALLS WITH REBARS EXPOSED, CRACKS WITH EFFLORESCENCE AND RUST STAINS.									
361	SCOUR	1	09-22-2008	1 EA	1	0	0	N/A	N/A
			09-11-2007	1 EA	1	0	0	N/A	N/A
Notes: 361. THERE IS SOME MINOR ACCIDENT DAMAGE TO THE DOWNSTREAM SIDE OF THE PIER PROTECTION AND THE WOOD PROTECTION AT WATER LEVEL IS NOT BOLTED TO THE BRACKETS. SOME TIMBERS ARE MISSING. (RATED K - LIMITED RISK. MONITORING REQUIRED.)									
964	CRITICAL FINDING	2	09-22-2008	1 EA	1	0	N/A	N/A	N/A
			09-11-2007	1 EA	1	0	N/A	N/A	N/A
Notes. Notes. 964. NO CRITICAL FINDINGS.									

Mn/DOT BRIDGE INSPECTION REPORT

Inspector: MINNEAPOLIS

BRIDGE 94246 BR#9 PED (ABAN RR) OVER MISS RIVER & W RIVER RD INSP. DATE: 09-22-2008**STRUCTURE UNIT: 0**

ELEM NBR	ELEMENT NAME	ENV	INSP. DATE	QUANTITY	QTY CS 1	QTY CS 2	QTY CS 3	QTY CS 4	QTY CS 5
981	SIGNING	2	09-22-2008	1 EA	1	0	0	0	0
			09-11-2007	1 EA	1	0	0	0	0
Notes: 981. HISTORICAL MARKERS AT BOTH ENDS. THE RIVER PIER HAS "NO WAKE ZONE" SIGNS ATTACHED.									
988	MISCELLANEOUS	2	09-22-2008	1 EA	0	1	0	N/A	N/A
			09-11-2007	1 EA	0	1	0	N/A	N/A
Notes: 988. LIGHTING: MISSING COVER PLATE DOWNSTREAM, CENTER OF CHANNEL.									

General Notes: *CITY BRIDGE #7214

NOTE: FOR ADDITIONAL INFORMATION LOOK IN SNOOPER REPORTS AND SCOUR REPORT.

NOTE: HNTB PERFORMED AN INSPECTION AND ANALYSIS IN 1986. IN 1994 THE STATE PERFORMED AN IN-DEPTH SNOOPER INSPECTION AND WOODWARD-CLYDE PERFORMED AN EVALUATION OF THE BRIDGE AS A POTENTIAL HISTORIC STRUCTURE.

NOTE: IN 2008 SEH CONSULTANTS DID A IN-DEPTH SNOOPER INSPECTION.

REPAIRS MADE: NO TRESPASSING SIGNS WERE INSTALLED, BROKEN DECK BOARDS AND LOOSE RAILING POSTS WERE REPAIRED IN 1987. THE S.W. PIER

PROTECTION WAS REPAIRED IN 1991. PIER PROTECTION AND BROKEN DECK BOARDS WERE REPAIRED IN 1993. FOUR SECTIONS OF BROKEN RAILING WERE REPAIRED IN 1995. THE BRIDGE DECK IS WAS REMODELED BY EDWARD KRAEMER AND SONS IN 1999. PERMANENT NAVIGATIONAL LIGHTS WERE ATTACHED IN 2000. LIGHTING ON BRIDGE NEW IN 2000. IN-DEPTH INSPECTION WITH ST. PAUL'S SNOOPER IN 2001.

CRACK SEALED THE SIDEWALK AND DECK IN 2002. 2006 U OF M LOCK REMOVED AND REPLACED BY CITY'S #43 KEY, U OF M CONTACT: GENE HUSTED, GENERAL FOREMAN-CELL 282-9572

NOTE: TWO SNOOPER INSPECTION WERE DONE IN 2007, ONE AFTER 35W COLLAPSE AND ONE WITH TKDA CONSULTANT REVIEWING OUR INSPECTION TECHNIQUES.

Inspector's Signature_____
Reviewer's Signature / Date

Bridge No. # 9 Over Mississippi River

Minneapolis Bridge #7214, State Bridge #94246
6/11/01

FIRST INSPECTION OF FRACTURE CRITICAL BRIDGE



INSPECTION CREW

Gary Stern
Kent Madsen
St. Paul Snooper
Ron Ekstrand

FRACTURE CRITICAL MEMBERS

INTRODUCTION & GENERAL CONDITION

FRACTURE CRITICAL BRIDGE INSPECTION

**The following quotes were taken from
MnDOT Technical Memorandum No. 96-03-B-01
March 6, 1996**

The purpose of the Fracture Critical Bridge Inspection "is to ensure the safety of fracture critical bridges in accordance with Minnesota Rule 8810, as well as federal regulations and guidelines which require appropriate inspection of bridge members which are fracture critical (23 CFR 650.303)."

"A fracture critical (FC) bridge has at least one fracture critical member or member component. Fracture critical members or member components (FCMs) are steel tension members or steel tension components whose failure would be expected to result in collapse of the bridge (Ref: AASHTO Manual for Maintenance of Bridges - 1994). An FCM lacks redundancy: if it fails there is no other member supporting a major part of the bridge."

OTHER SOURCES OF INFORMATION

If desired the following information sources may also be referred to:
Yearly Bridge Inspection Reports by Mpls. Bridge Inspections

FRACTURE CRITICAL MEMBERS

BRIDGE DESCRIPTION

The bridge is a two span steel deck truss and five span approach deck girders, built in 1922. With a remodeled concrete deck in 1999.

NOTE KEEPING NUMBERING SYSTEM

The vertical stiffeners on all girders were numbered from west bank to east bank as a convenient way to break down each truss into small sections for inspection note keeping (lower truss L0, L1, L2, etc., upper truss U0, U1, U2, etc.). The spans and piers numbered from the east bank to the west bank following the 1922 bridge plans. The stringer, bearings and girders are number from downstream to upstream side.

Abutment #8-The bearings are fixed and with rust. Bearing #1 NE corner is missing anchor bolt. Bearing #2 SE corner anchor bolt is bent and NE anchor bolt is missing. Bearing #3 SE is missing anchor bolt. Bearing #4 SE anchor bolt is bent and NE is gone. No debris on cap.

Span #7- No. #3 girder has 12' of rust on the bottom flange with pack rust. All girders have 70% lose of paint. Under deck fine.

Pier #7-The concrete cap is full of ballast. The concrete cap is spalled, delaminated and rebars exposed. All west (movable) bearing marks have not moved and are rusted and have pack rust with anchor bolts missing. Bearings #1 and #3 top rocker has one bolt missing. Bearing #1 and #2 connected at the bottom of the girder are bent or warped from the bearings not working. East side (fixed) bearings #1 and #3 upper bolt is missing on the rocker. Many bottom anchor bolts are missing (See picture #1).

Span #6-The girders have 70% lose of paint.

Pier #6-West side (movable) bearings #1 and #3 top rocker bolts are missing. Rocker bearing #1 and #2 rusted with pack rust and #1 is bent or warp at the girder flange (See picture #2, #4, #5 and #6). Bearings #3 and #4 are frozen open with rust and pack rust (See picture #3). East side (fixed) bearings have many bolts missing from the upper rocker. The lower anchor bearing bolts #1, #2 and #3 have bolts missing.

Span #5-The girders have 70% lose of paint

Pier #5-The upper hinges have some metal missing from the bearing plates to the west. The steel column upper rockers on #1 and #3 have some bolts missing. Bearing at L0 (fixed) are rusted with some debris around them. The chain link fence and gate are in disrepair. The upstream truss at U0 hinge is missing one bolt and nut.

Span #4-downstream truss-L1 hauger has pack rust. Strut at U2 is not in tension at all and is bent. L3 is full of rust and pack rust. M3 the bolt has some packrust. U4 has heavy paint flaking. L4 has light paint flaking and rust. M4 has 95% paint loss. L5 has some minor packrust and paint flaking. M6 both struts are bent. **Center truss-** L3 the gusset plate has rust and graffiti. L5 has one rivet missing. U6 the beam gusset plate has pack

rust. **Upstream truss**-L1 has packrust around hanger and pin. U1 to center truss the false work is in place with clamps. M2 has packrust and the pin spacer is pushed out 2". L3 from upstream truss to L3 center truss is missing one rivet. The gusset plate spacer at U3 has packrust and a crack also has pack rust and push away from the beam. L4 upstream truss to L5 center truss is severely bent (about 2' pushed down). The counter from U4 to L5 is bent. M4 the pin has packrust around it. The gusset plate spacer at U5 has packrust and a crack. M5 has packrust and the pin spacer is pushed up 2".

Pier #4- At L8 the bearings are frozen in place with pack rust and some loss of member on the bearing sliders.

Span #3-downstream truss- The bottom flange of the top beam 2' east of U1 is bent up 2". Between U1 and U2 and between downstream side and inside truss sway bar are twisted. From U1 and L1 the hanger is bent. L1 has some packrust with paint loss. L2 has packrust throughout and paint loss. M1 to Strut U2 are slightly bent. U3 gusset plate west side has packrust throughout. L6 has some packrust and paint flaking. **Center truss**-U2 and U3 have packrust. The sway bar between U1 and U2 has heavy packrust. **Upstream truss**- Between U8 to U1 the false work is still in place at the expansion joint. L1 the pin spacer holding the hangers has packrust and is open about 1". L1 to U1 the hangers are bent. M2 the coupling has packrust and the pin spacer is pushed open 2". The gusset plate spacer at U3 has packrust with a small hole through it. M5 is packrusted and the pin spacer is pushed up 2". Strut at M6 has packrust and the pin spacer is push out 2".

Pier #3-The #4 hinge on the downstream side are moving and the #4 hinge upstream side are frozen. The #2 bearing rocker at the girder has one sheared bolt and all rockers rusted top and bottom. The steel columns are 50% loss of paint with some rust. The bearing to the truss (movable) are rusted with packrust and the rockers are locked or frozen in place.

Span #2-The bottom flanges have heavy rust with little paint. The underdeck has some small spalls.

Pier #2- West side (fixed) bearings are rusted throughout and the base pins or bolts on some are bent and rusted. East side (movable) bearings are rusted with packrust and froze in place. The rockers are in different positions. Bearing #4 has two pins not connected on the top rocker plate and the bolts are sticking out 1" on both. The top of the pier caps are full of debris. The ends of the cap are delaminated with spalls and rebar exposed.

Span #1-The girders and sway bars are rusted and the top and lower flanges have no paint left. Some small spalls between girder #3 and #4 (1' X 1') with rebars exposed. The bottom to the deck upstream side is delaminated for 15'.

Abutment #1-Fixed bearing are rusted throughout. The abutment cap is delaminated, spalled and full of debris.



Picture #1

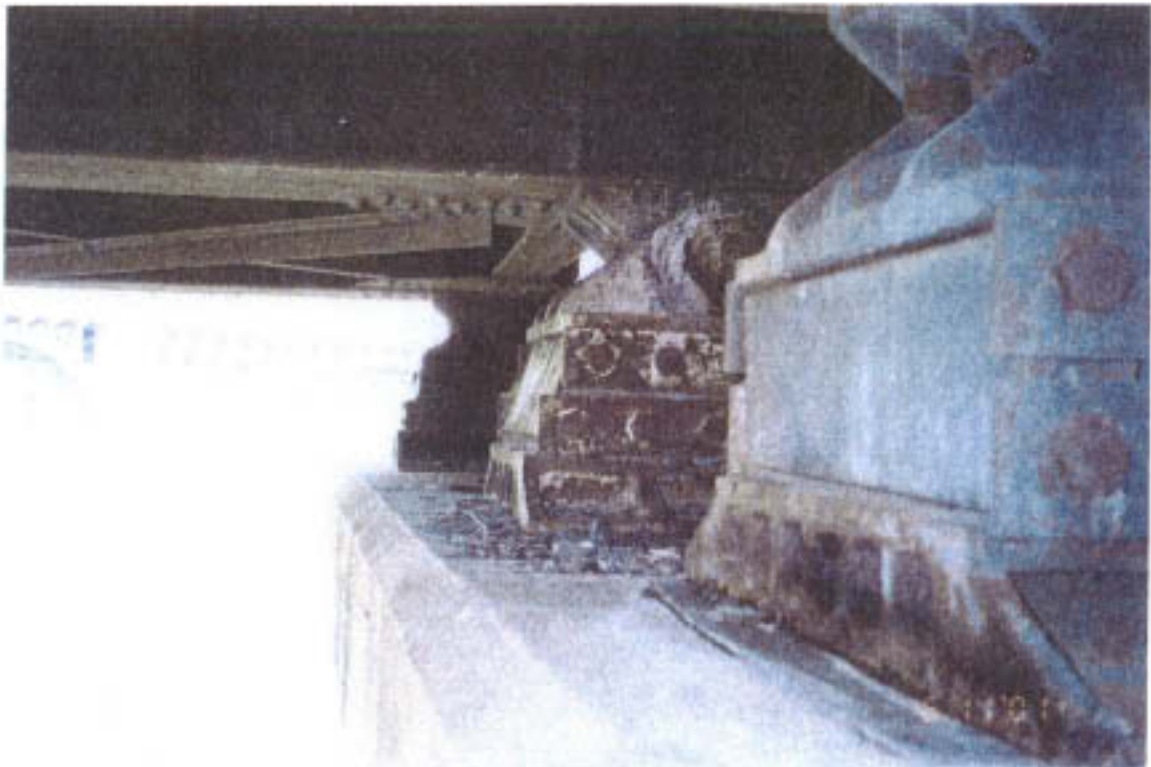

Picture #2



Picture #3

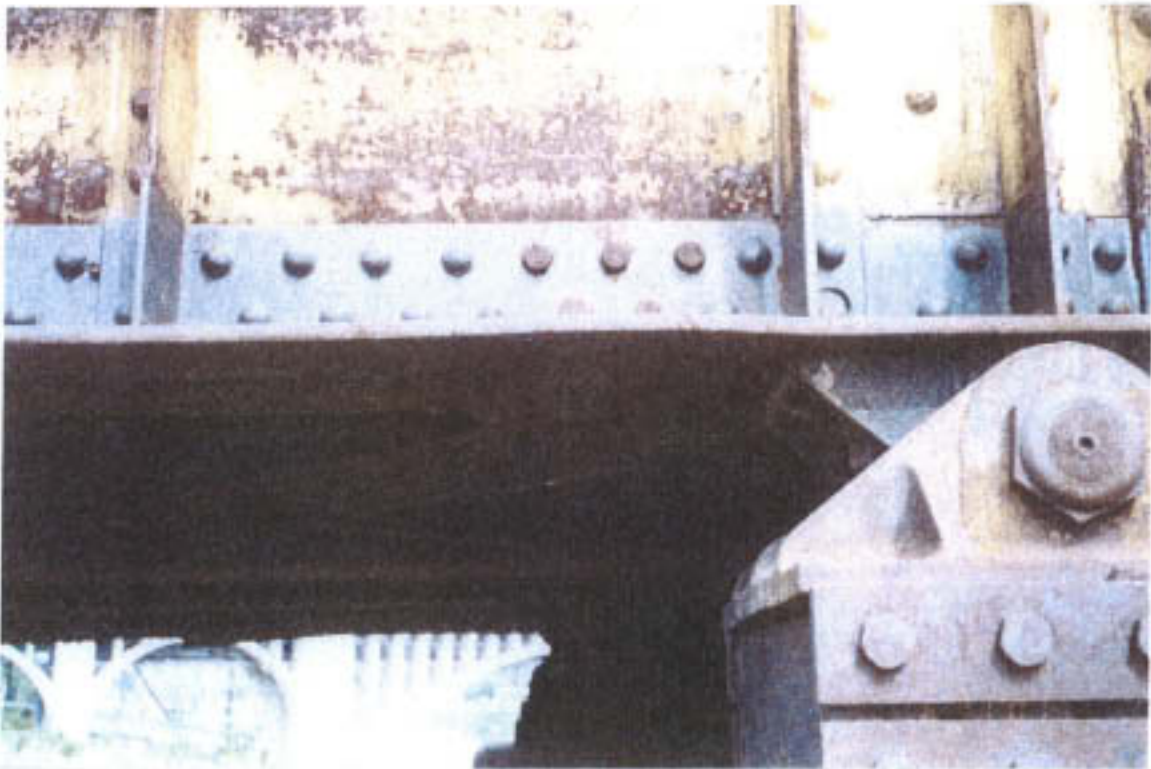

Picture #4

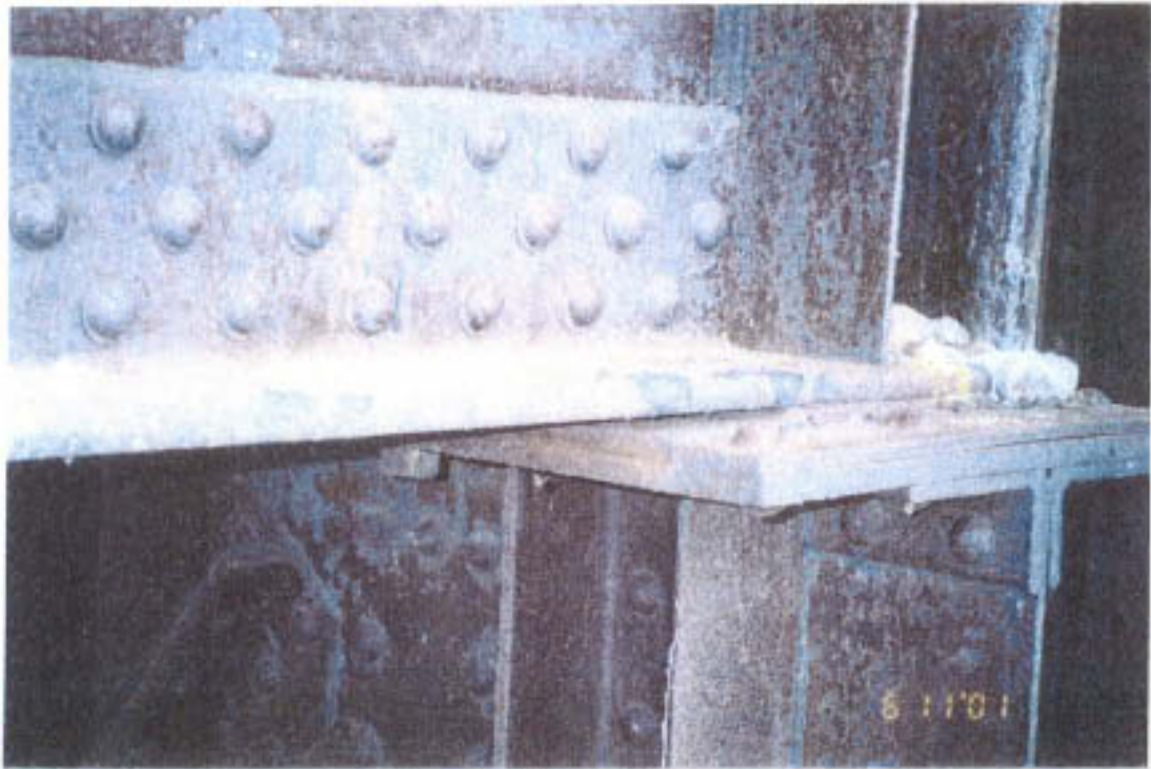

Picture #5



Picture #6

NO-7214.DOC

Bridge No. # 9 Over
Mississippi River

Minneapolis Bridge #7214, State Bridge #94246

9/25/2006 Kent Madsen

9/26/2006 John Beetsch

**INSPECTION OF FRACTURE
CRITICAL BRIDGE**



INSPECTION CREW

Kent Madsen

John Beetsch

UNDER BRIDGE INSPECTION UNIT CREW

John Miller

Vance Strood

Jeff Olson (Boat)

FRACTURE CRITICAL MEMBERS

INTRODUCTION & GENERAL CONDITION

FRACTURE CRITICAL BRIDGE INSPECTION

The following quotes were taken from
MnDOT Technical Memorandum No. 96-03-B-01
March 6, 1996

The purpose of the Fracture Critical Bridge Inspection "is to ensure the safety of fracture critical bridges in accordance with Minnesota Rule 8810, as well as federal regulations and guidelines which require appropriate inspection of bridge members which are fracture critical (23 CFR 650.303)."

"A fracture critical (FC) bridge has at least one fracture critical member or member component. Fracture critical members or member components (FCMs) are steel tension members or steel tension components whose failure would be expected to result in collapse of the bridge (Ref: AASHTO Manual for Maintenance of Bridges - 1994). An FCM lacks redundancy; if it fails there is no other member supporting a major part of the bridge."

OTHER SOURCES OF INFORMATION

If desired the following information sources may also be referred to:

- Yearly Bridge Inspection Reports by Mpls. Bridge Inspections

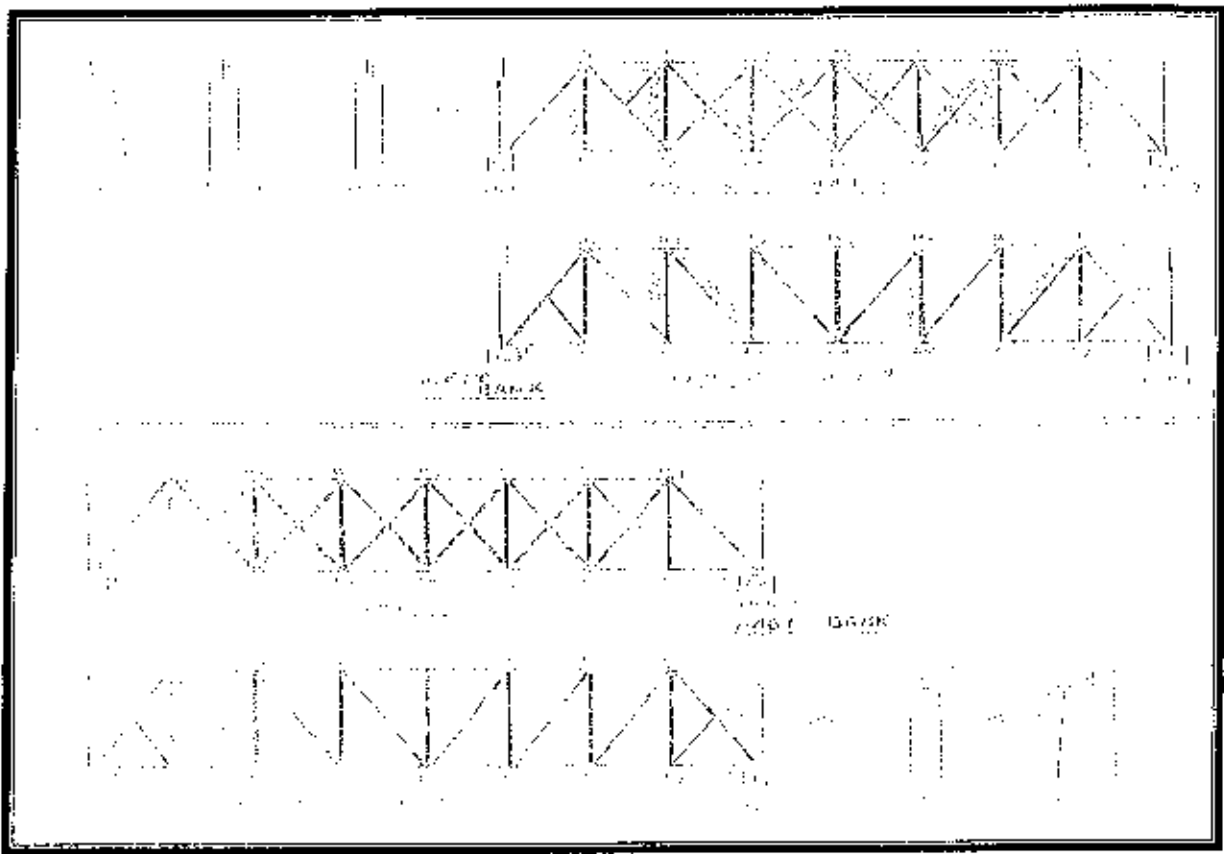

FRACTURE CRITICAL MEMBERS

BRIDGE DESCRIPTION

The bridge is a two span steel deck truss and five span approach deck girders, built in 1922. With a remodeled concrete deck in 1999.

NOTE KEEPING NUMBERING SYSTEM

The vertical stiffeners on all girders were numbered from west bank to east bank as a convenient way to break down each truss into small sections for inspection note keeping (lower truss L0, L1, L2, etc., upper truss U0, U1, U2, etc.). The spans and piers numbered from the east bank to the west bank following the 1922 bridge plans. The stringer, bearings and girders are number from downstream to upstream side.

Abutment #8-The bearings are fixed and with rust. Bearing #1 NE corner is missing anchor bolt. Bearing #2 SE corner anchor bolt is bent and NE anchor bolt is missing. Bearing #3 SE is missing anchor bolt. Bearing #4 SE anchor bolt is bent and NE is gone. Debris on cap. Heavy Graffiti.

Span #7- No. #3 girder has 12' of rust on the bottom flange with pack rust. All girders have 70% lose of paint. Under deck some spalls, some seepage at center joint. Downstream fascia is spalled with rebar exposed. Upstream deck between 3 & 4 is spalled with rebar exposed.

Pier #7-The concrete cap is full of ballast. Heavy Graffiti west side. The concrete cap is spalled, delaminated and rebars exposed. Bearing #1 some loss of bearing. **(Picture #1)** All west (movable) bearing marks have not moved and are rusted and have pack rust with anchor bolts missing. Bearings #1 and #3 top rocker has one bolt missing. #3 is missing bottom plate and 5 bolts. **(Picture #2)** Bearing #1 and #2 connected at the bottom of the girder are bent or warped from the bearings not working. East side (fixed) bearings #1 and #3 upper bolt is missing on the rocker. Many bottom anchor bolts are missing. Heavy seepage over bearing #3 eastside of joint. Bearing #4 is tilted to the west.

Span #6-The girders have 70% lose of paint. Under deck has some spalls with rebar exposed. Heavy seepage at center joint.

Pier #6-West side (movable) bearings #1 and #3 top rocker bolts are missing. Rocker bearing #1 and #2 rusted with pack rust and #1 is bent or warp at the girder flange. Bearings #3 and #4 are frozen open with rust and pack rust. East side (fixed) bearings have many bolts missing from the upper rocker. The lower anchor bearing bolts #1, #2 and #3 have bolts missing. Pier face has some spalls with rebar exposed. Cap is delaminated and spalled. **(See picture #2 is west bearing #4)**

Span #5-The girders have 70% lose of paint. Heavy seepage at center joint, with calcium carbonates leaching out and building up on the lower cord in all spans.

Pier #5-The upper hinges have some metal missing from the bearing plates to the west. The steel column upper rockers on #1 and #3 have some bolts missing. Bearing at L₀ (fixed) are rusted with some debri around them. The chain link fence and gate are in disrepair. The upstream truss at U₀ hinge is missing one bolt and nut. Cap is delaminated and spalled. Heavy graffiti on pier.

Span #4-

Downstream truss-L1 hanger has pack rust. Strut at U2 is not in tension at all and is bent. L3 is full of rust and pack rust. M3 the bolt has some packrust. U4 has heavy paint flaking. L4 has light paint flaking and rust. M4 has 95% paint loss. L5 has some minor packrust and paint flaking. M6 both struts are bent.

Center truss- L3 the gusset plate has rust and graffiti. L5 has one rivet missing. U6 the beam gusset plate has pack rust.

Upstream truss-L1 has packrust around hanger and pin. U1 to center truss the false work is in place with clamps. M2 has packrust and the pin spacer is pushed out 2". L3 from upstream truss to L3 center truss is missing one rivet. The gusset plate spacer at U3 has packrust and a crack also has pack rust and push away from the beam. L4 upstream truss to L5 center truss is severely bent (about 2' pushed down). The counter from U4 to L5 is bent. M4 the pin has packrust around it. The gusset plate spacer at U5 has packrust and a crack. M5 has packrust and the pin spacer is pushed up 2". Outside diagonal from U4 to M3 is bent out 1". Vertical at L7 to V7 bent in 2".

Pier #4- At L8 the bearings are frozen in place with pack rust and some loss of member on the bearing sliders. Concrete cap is deteriorating, spalled and delaminated. Bearing #3 westside has 4 bolts missing.

Span #3-

Downstream truss- The bottom flange of the top beam 2' east of U1 is bent up 2". Between U1 and U2 and between downstream side and inside truss sway bar are twisted. From U1 and L1 the hanger is bent. L1 has some packrust with paint loss. L2 has packrust throughout and paint loss. M1 to Strut U2 are slightly bent. U3 gusset plate west side has packrust throughout. L6 has some packrust and paint flaking. One of the counters from U4 to M4 is starting to corroded at M4.

Center truss-U2 and U3 have packrust. The sway bar between U1 and U2 has heavy packrust.

Upstream truss- Between U8 to U1 the false work is still in place at the expansion joint. L1 the pin spacer holding the hangers has packrust and is open about 1". L1 to U1 the hangers are bent. M2 the coupling has packrust and the pin spacer is pushed open 2". The gusset plate spacer at U3 has packrust with a small hole through it. M5 is packrusted and

the pin spacer is pushed up 2". Strut at M6 has packrust and the pin spacer is pushed out 2".

Pier #3- The #4 hinge on the downstream side are moving and the #4 hinge upstream side is frozen. The #2 bearing rocker at the girder has one sheared bolt and all rockers rusted top and bottom. The steel columns are 50% loss of paint with some rust. The bearing to the truss (movable) are rusted with packrust and the rockers are locked or frozen in place. Cap at #1 & #4 is spalling and undermined at the outsides.

Span #2- The bottom flanges have heavy rust with little paint. The underdeck has some small spalls.

Pier #2- West side (fixed) bearings are rusted throughout and the base pins or bolts on some are bent and rusted. East side (movable) bearings are rusted with packrust and froze in place. The rockers are in different positions. Bearing #4 has two pins not connected on the top rocker plate and the bolts are sticking out 1" on both. The top of the pier caps are full of debris. The ends of the cap are deteriorating to a point that bearing #1 westside is starting to undermined. **In Pictures 3 and 4 you can see how much of the cap is spalled off. The cap under Bearing #1 needs to be watched for additional deterioration and possible loss of bearing.**

Span #1- The girders and sway bars are rusted and the top and lower flanges have no paint left. Some small spalls between girder #3 and #4 with rebars exposed. The bottom to the deck upstream side is delaminated for 15'. Some minor spalls between #2 & #3 at center line joint.

Abutment #1- Fixed bearing are rusted throughout. The abutment cap is delaminated, spalled and full of debris.



Picture #1



Picture #2



Picture #3



Picture #4



Picture #5

NO-7214 #9

MEMORANDUM

To: Don Elwood, City of Minneapolis
Copies To: Jeff Johnson, City of Minneapolis
Kevin Cullen, TKDA

Reference: Pedestrian Bridge #9
(Mn/DOT Bridge No. 94246)
Bridge Inspection Peer Review
City of Minneapolis, Minnesota

From: Hans L. Erickson, P.E., S.E.
Date: August 10, 2007

Proj. No.: 13990.000
Routing: _____

As requested by the City of Minneapolis, TKDA is in the process of conducting a peer review of the City's bridge inspection program. One element of the peer review consisted of spot-checking components of recently inspected bridges for comparison with information presented in the bridge safety inspection reports. To accommodate scheduling of City equipment and staff and to perform the review while the structure is closed to traffic, spot-checking of Pedestrian Bridge #9 (Mn/DOT Bridge No. 94246) was completed on August 9, 2007, prior to full completion of the entire peer review. The following report presents only the findings of the spot-checking portion of the review.



Pedestrian Bridge #9 (Mn/DOT Bridge No. 94246)

The spot check review did not consist of a complete Condition State rating of every component on the bridge. "Spot-checking" only refers to a visual inspection of a portion of the selected bridge components. A portion of the following bridge components were selected for considered:

- Bearing Assemblies
- Main span truss
- Pier walls
- Pier caps

These components were selected for this portion of the review because they had been previously inspected by the City on Friday, August 3, 2007, in response to the I-35W bridge collapse.

Only comparisons of Condition State ratings were made. Investigations of the quantities used for each element were not made for this portion of the study. The City provided TKDA with a copy of the most recent Mn/DOT Bridge Inspection Report, which indicates that the prior safety inspection of this structure was performed on April 26, 2006. Additional information provided by the City included the fracture critical bridge inspection report which was performed on September 25-26, 2006, by the City's bridge safety inspection staff. Spot check comparisons were made only with the information presented in the Mn/DOT Bridge Inspection Report.

Access to the bridge components was made via the City's snooper truck, from an inspection catwalk located on the main span truss at the lower chord elevation, and from the ground under the bridge on the river's west bank.

Element 313—Fixed Bearing Assemblies

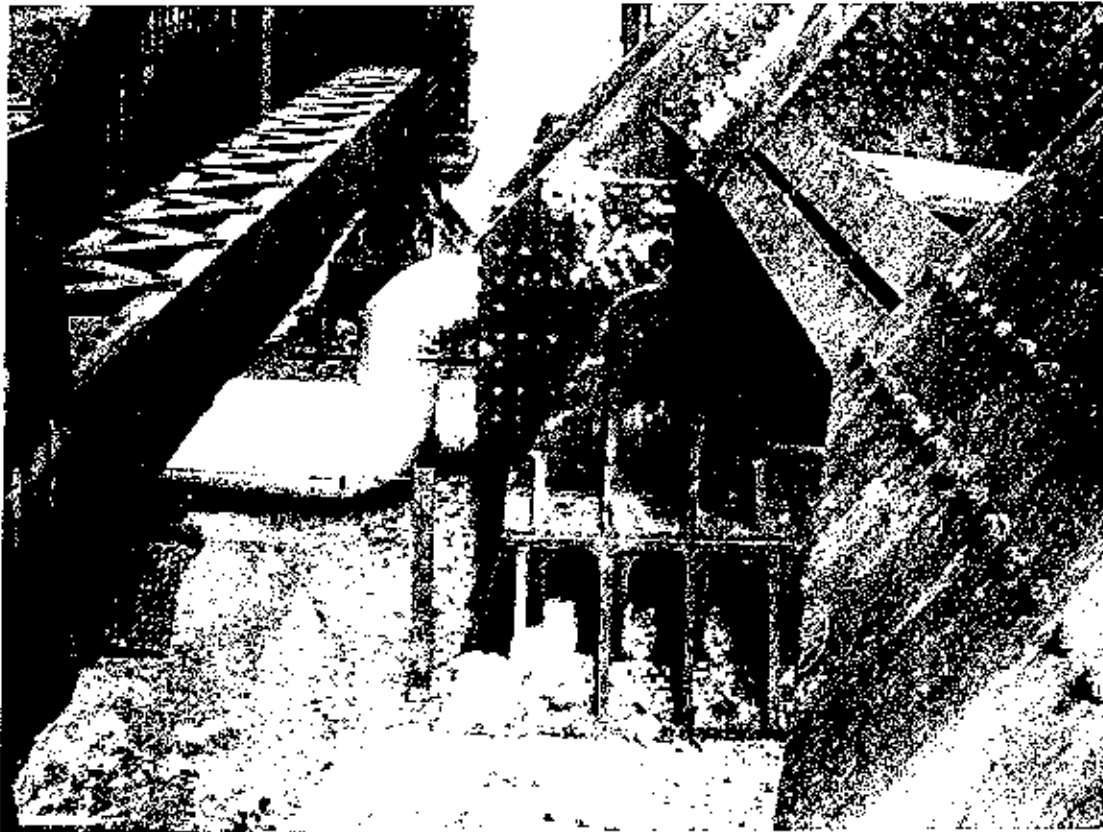

Spot-Checked Fixed Bearing Assembly

All of the fixed bearing assemblies are rated at Condition State Level 2 on the current Mn/DOT Bridge Inspection Report. According to the Mn/DOT *Bridge Inspection Manual*, Condition State Level 2 for fixed bearings is defined as follows:

Fixed Bearing has moderate deterioration - cleaning or painting may be recommended. Bearing assembly may have extensive corrosion (section loss may be present), or may be covered with debris. Primary bearing components (castings, pins, pads, etc.) may be moderately worn or slightly out of alignment. Secondary bearing components (cotter pins, lead plates, sole plate bolts, etc.) may be working out, loose, or missing. Anchor bolts may be corroded, but remain intact. The bearing seat may have moderate deterioration (there may be slight loss of bearing area).

Based on our spot check review of the fixed bearing assemblies, we believe the Condition State rating of Level 2 to be appropriate.

Element 311—Expansion Bearing Assemblies

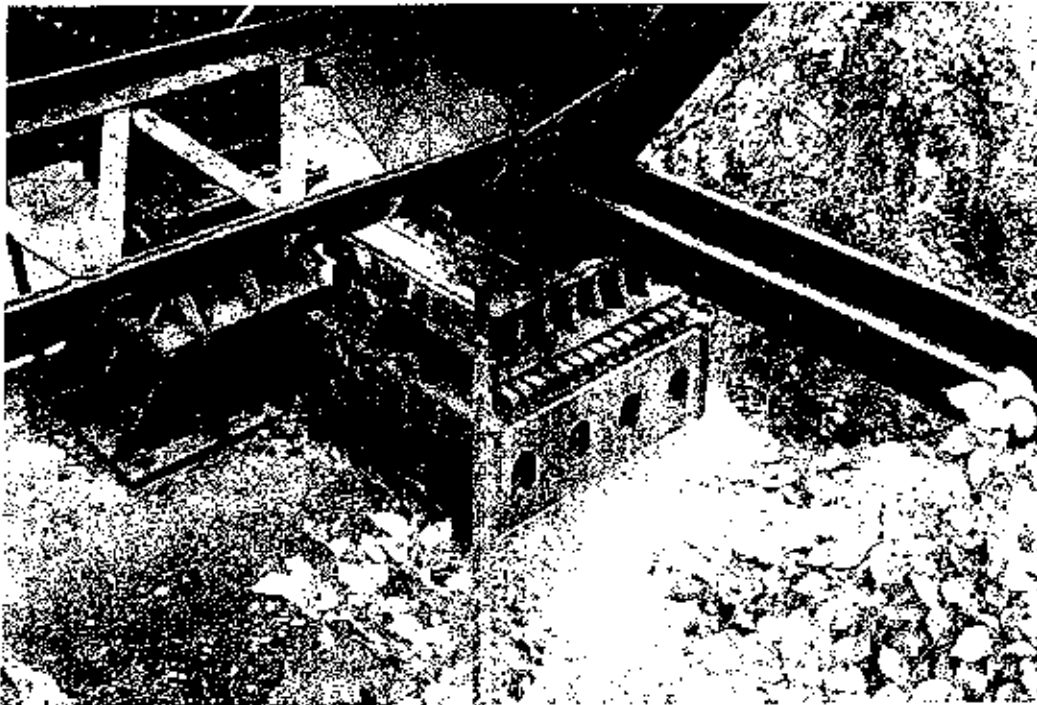

Spot-Checked Expansion Bearing Assembly

All of the expansion bearing assemblies are rated at Condition State Level 2 on the current Mn/DOT Bridge Inspection Report. According to the Mn/DOT *Bridge Inspection Manual*, Condition State Level 2 for expansion bearings is defined as follows:

Expansion Bearing has moderate deterioration - bearing function may be slightly restricted (cleaning, painting, or lubrication may be recommended). Bearing alignment may be at or near the design limits (or inappropriate for the current temperature), but is still tolerable. Bearing assembly may have extensive corrosion (section loss may be present), or may be covered with debris. Lubrication system may have failed. Primary bearing components (sliding plates, rockers, rollers, pins, etc.) may be moderately worn or slightly out of alignment. Secondary bearing components (cotter pins, etc.) may be loose or missing. The lateral guide/restraint system (guide tabs, keeper bars, pintles, pin caps, etc.) may be moderately worn or slightly out of alignment (there may be minor binding). Uplift restraint system (if present) may have moderate deterioration, but is still functioning as intended. Anchor bolts may be corroded or bent, but remain intact. The bearing seat may have moderate deterioration (there may be a slight loss of bearing area).

Based on our spot check review of the expansion bearing assemblies, we believe the Condition State rating of Level 2 to be appropriate.

Element 130—Weathering Steel Deck Truss



Spot-Checked Weathering Steel Deck Truss

City inspectors have correctly noted that this element should be changed to a painted steel deck truss, not the weathering steel deck truss currently listed on the inspection report.

The entire length of the steel deck truss is rated at Condition State Level 3 on the current Mn/DOT Bridge Inspection Report. According to the Mn/DOT *Bridge Inspection Manual*, Condition State Level 3 for a painted steel deck truss is defined as follows:

Painted steel element has moderate deterioration. The paint system may have extensive deterioration. Surface corrosion (freckled rust) may be prevalent - there may be isolated flaking rust (with minor section loss). Repainted elements may have measurable section loss in non-critical locations. Connections may have minor distress - element may be slightly out of alignment.

Our spot check review of the steel deck truss did not find any areas of extensive deterioration or significant section loss of the main members. Some misalignment of the diagonal members was observed and complete loss of the paint system was observed throughout. We believe the Condition State rating of Level 3 to be appropriate for a painted steel member.

Element 210—Concrete Pier Walls

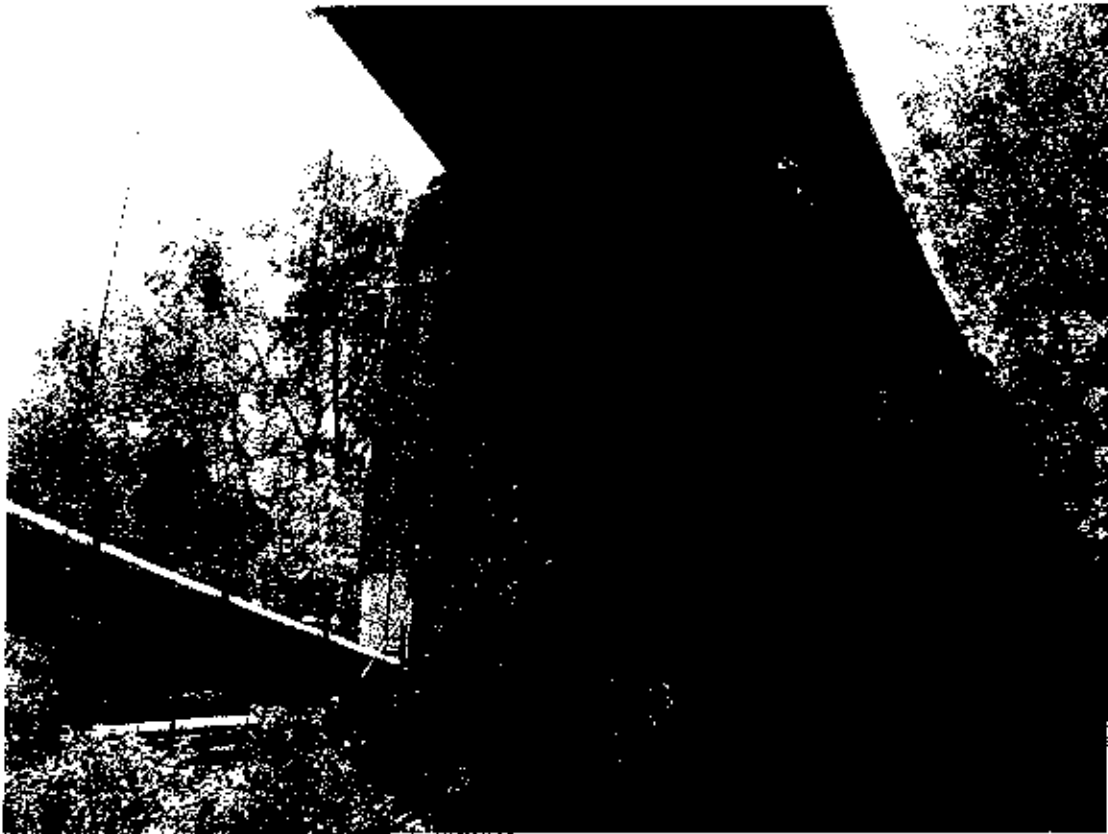

Spot-Checked Concrete Pier Wall

The entire length of the concrete pier walls is rated at Condition State Level 2 on the current Mn/DOT Bridge Inspection Report. According to the Mn/DOT *Bridge Inspection Manual*, Condition State Level 2 for concrete pier walls is defined as follows:

Reinforced concrete element has minor to moderate deterioration. There may be moderate cracking, leaching, staining, or surface scale. Minor delaminations or spalls may be present, but there is little or no exposure of steel reinforcement. Element is in proper position and alignment - all connections are sound. Repair patches (if any) remain sound.

Based on our spot check review of the concrete pier walls, we believe the Condition State rating of Level 2 to be appropriate.

Element 210—Reinforced Concrete Pier Cap



Spot-Checked Reinforced Concrete Pier Cap

The entire length of the reinforced concrete pier caps is rated at Condition State Level 2 on the current Mn/DOT Bridge Inspection Report. According to the Mn/DOT *Bridge Inspection Manual*, Condition State Level 2 for reinforced concrete pier caps is defined as follows:

Reinforced concrete element has minor to moderate deterioration. There may be moderate cracking, leaching, staining, or surface scale. Minor delaminations or spalls may be present, but there is little or no exposure of steel reinforcement. Element is in proper position and alignment - all connections are sound. Repair patches (if any) remain sound.

Based on our spot check review of the reinforced concrete pier caps, we believe the Condition State rating of Level 2 to be appropriate for portions of the pier cap; however, observed conditions closer to Condition State Level 3 were also observed. According to the Mn/DOT *Bridge Inspection Manual*, Condition State Level 3 for reinforced concrete pier caps is defined as follows:

Reinforced concrete element has extensive deterioration, but the load-carrying capacity of the element has not been significantly reduced. There may be extensive cracking, leaching, staining, or scale. Structural cracking (from shear or flexure) may be present. Delaminations

and spalls may be prevalent. Exposed reinforcement may have corrosion, but any section loss is incidental and does not significantly affect the strength and/or serviceability of either the element or the bridge. Element may be slightly out of position or alignment - connections may have started to come loose.

Examples of the observed elements warranting a Condition State Level 3 rating may be seen in the following photos.



Exposed Rebar and Spalled Concrete at End of Cap



Spalled Concrete on Edge of Pier Cap

Conclusions

Based on the findings of our spot check review, TKDA agrees with the majority of the Condition State ratings of the elements observed. The only observation which contradicted previous inspections was made on the reinforced concrete pier cap. The current Mn/DOT Bridge Inspection Report indicates that the entire length of the reinforced concrete pier caps is rated at Condition State Level 2. Based on our spot check review observations, we believe portions of the reinforced concrete pier caps warrant a Condition State rating of Level 3.

UNDERWATER BRIDGE INSPECTION REPORT

STRUCTURE NO. 94246

ABANDONED RR SOUTH OF CEDAR

OVER THE

MISSISSIPPI RIVER

DISTRICT 5 - HENNEPIN COUNTY, CITY OF MINNEAPOLIS



PREPARED FOR THE

MINNESOTA DEPARTMENT OF TRANSPORTATION

BY

COLLINS ENGINEERS, INC.

JOB NO. 5221 (CEI 18A)

MINNESOTA DEPARTMENT OF TRANSPORTATION
UNDERWATER BRIDGE INSPECTION

REPORT SUMMARY:

The substructure unit inspected at Bridge No. 94246, Pier 4, was found to be in good condition below water with no defects of structural significance. Overall, the conditions at the bridge have not changed appreciably since the last inspection. The steel sheeting encasement exhibited moderate surface corrosion with no appreciable loss of section. The timber fender system protecting Pier 4 was in fair to at times poor condition with some areas of failed connections, missing members, and impact damage. The channel bottom was stable with no evidence of significant scour or appreciable changes since the previous inspection.

INSPECTION FINDINGS:

- (A) The steel sheeting encasing the concrete pier below water displayed a uniform 1/8 inch layer of moderate corrosion, random 1 inch diameter rust nodules, and random 1/8 inch deep pitting.
- (B) The timber fenders showed signs of moderate decay and rot at the waterline along with some failed connections, missing members, and impact damage.

RECOMMENDATIONS:

- (A) Depending on the proposed future use of the structure, consideration can be given to replacing the missing, deteriorated and damaged timber fender components during normal maintenance operations.

- (B) Reinspect the submerged substructure unit at the normal maximum recommended (NBIS) interval of five (5) years.

I hereby certify that this plan, specification, or report was prepared by me or under my direct supervision and that I am a duly Licensed Professional Engineer under the laws of the State of Minnesota.

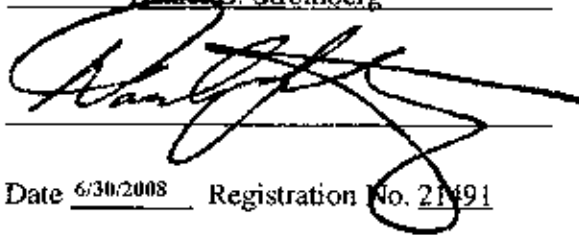
Daniel G. Stromberg

Date 6/30/2008 Registration No. 21491

Respectfully submitted,

COLLINS ENGINEERS, INC.

Daniel G. Stromberg
Registered Professional
Engineer, State of Minnesota

MINNESOTA DEPARTMENT OF TRANSPORTATION
UNDERWATER BRIDGE INSPECTION

1. BRIDGE DATA

Bridge Number: 94246

Feature Crossed: Mississippi River

Feature Carried: Abandoned RR South of Cedar

Location: District 5 - Hennepin County, City of Minneapolis

Bridge Description: The superstructure consists of a steel deck truss over seven spans. The superstructure is supported on reinforced concrete abutments and piers. Plans indicate that the pier and abutment footings are spread footings bearing on sandstone. The abutments and piers are numbered 1 through 8 from east to west.

2. INSPECTION DATA

Professional Engineer/Team Leader: Daniel G. Stromberg, P.E., S.E.

Dive Team: Todd Demski, John J. Loflus, Valerie Rouston.

Date: August 30, 2007

Weather Conditions: Sunny, $\approx 65^{\circ}$ F

Underwater Visibility: 0.5 Feet

Waterway Velocity: 1.0 f.p.s.

3. SUBSTRUCTURE INSPECTION DATA

Substructure Inspected: Pier 4

General Shape: The pier consists of a rectangular reinforced concrete shaft encased in an oblong rectangular steel sheet pile encasement (perimeter wall construction) filled with concrete. The sheet piling was faced with a timber fender system above the waterline.

Maximum Water Depth at Substructure Inspected: Approximately 14.9 feet.

4. WATERLINE DATUM

Water Level Reference: The top of the steel sheeting pile encasement on the downstream end of Pier 4.

Water Surface: The waterline was approximately 11.6 feet below reference.
Waterline Elevation = 725.4.

5. NBIS CODING INFORMATION (Minnesota specific codes are used for 92B and 113)

Item 60: Substructure: Code 7

Item 61: Channel and Channel Protection: Code 8

Item 92B: Underwater Inspection: Code B/08/07

Item 113: Scour Critical Bridges: Code C/95

Bridge is scour critical because abutment or pier foundation is rated as unstable due to observed scour at bridge site.

 Yes X No



Photograph 1. View of Downstream End of Pier 4, Looking North.



Photograph 2. View of Damaged Fender System at Upstream Half of Pier 4, Looking West.

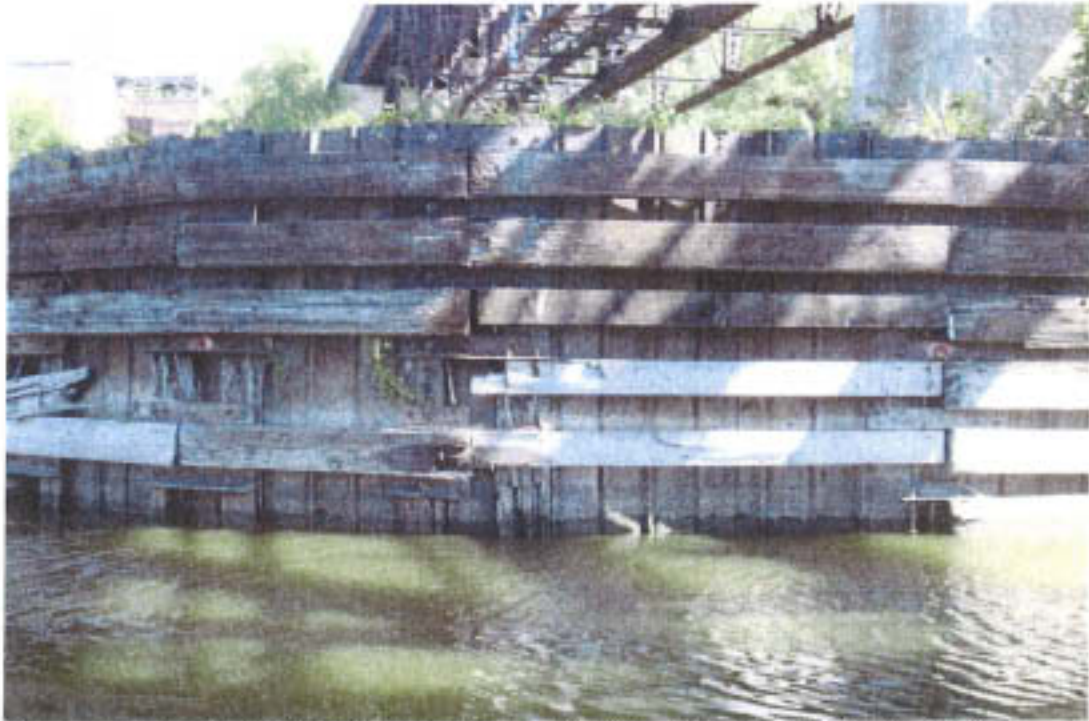

Photograph 3. View of the Damaged Fender System at Upstream Nose of Pier 4, Looking East.



Photograph 4. View of the Damaged Fender System at Downstream Half of Pier 4, Looking East.

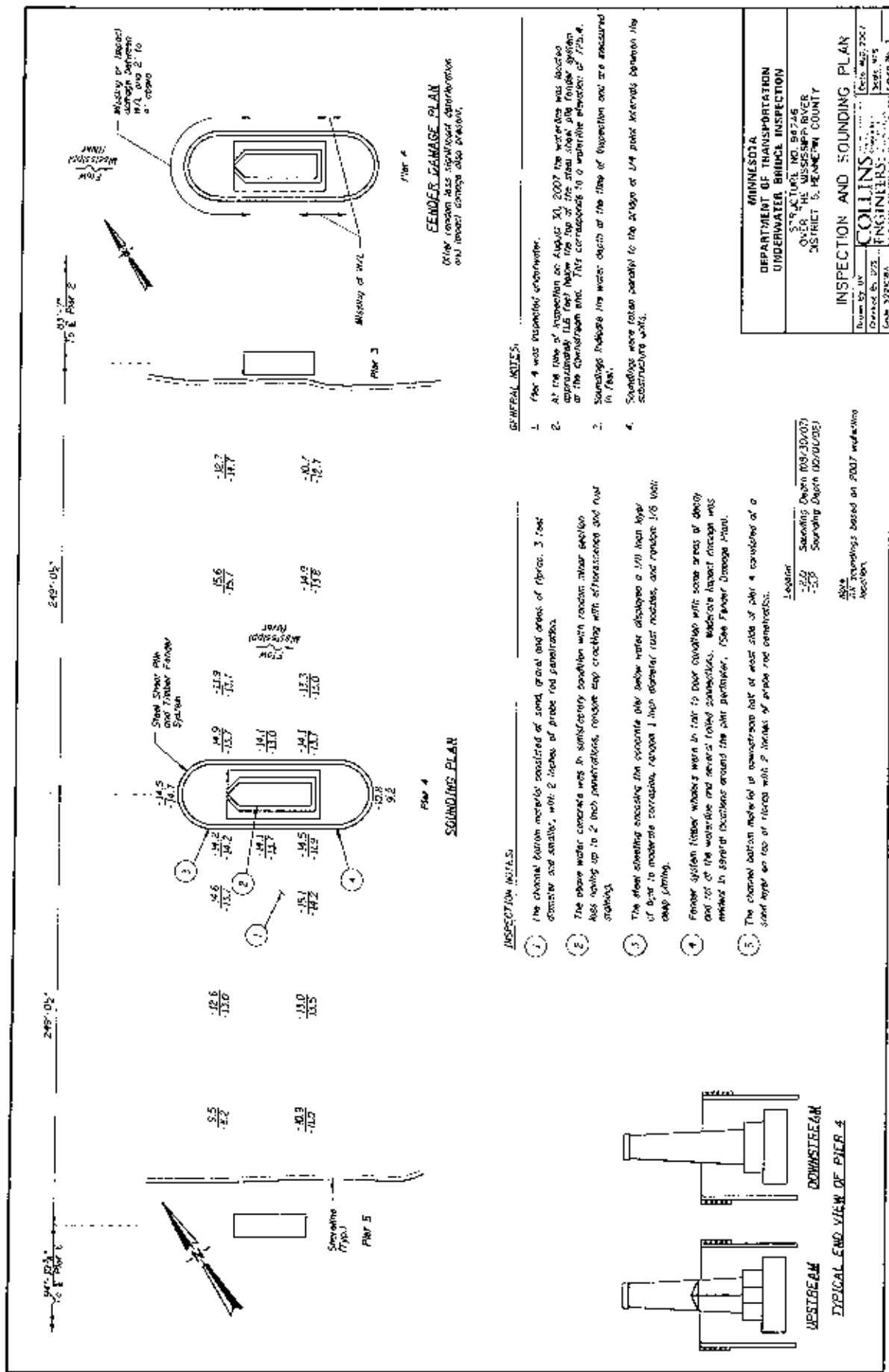

EENDER DAMAGE PLAN
 Other random less significant observations on Eender damage also present.

SOUNDING PLAN

WEST BEAM
DOWNSIDE VIEW
EAST BEAM
TYPICAL END VIEW OF PIER 4

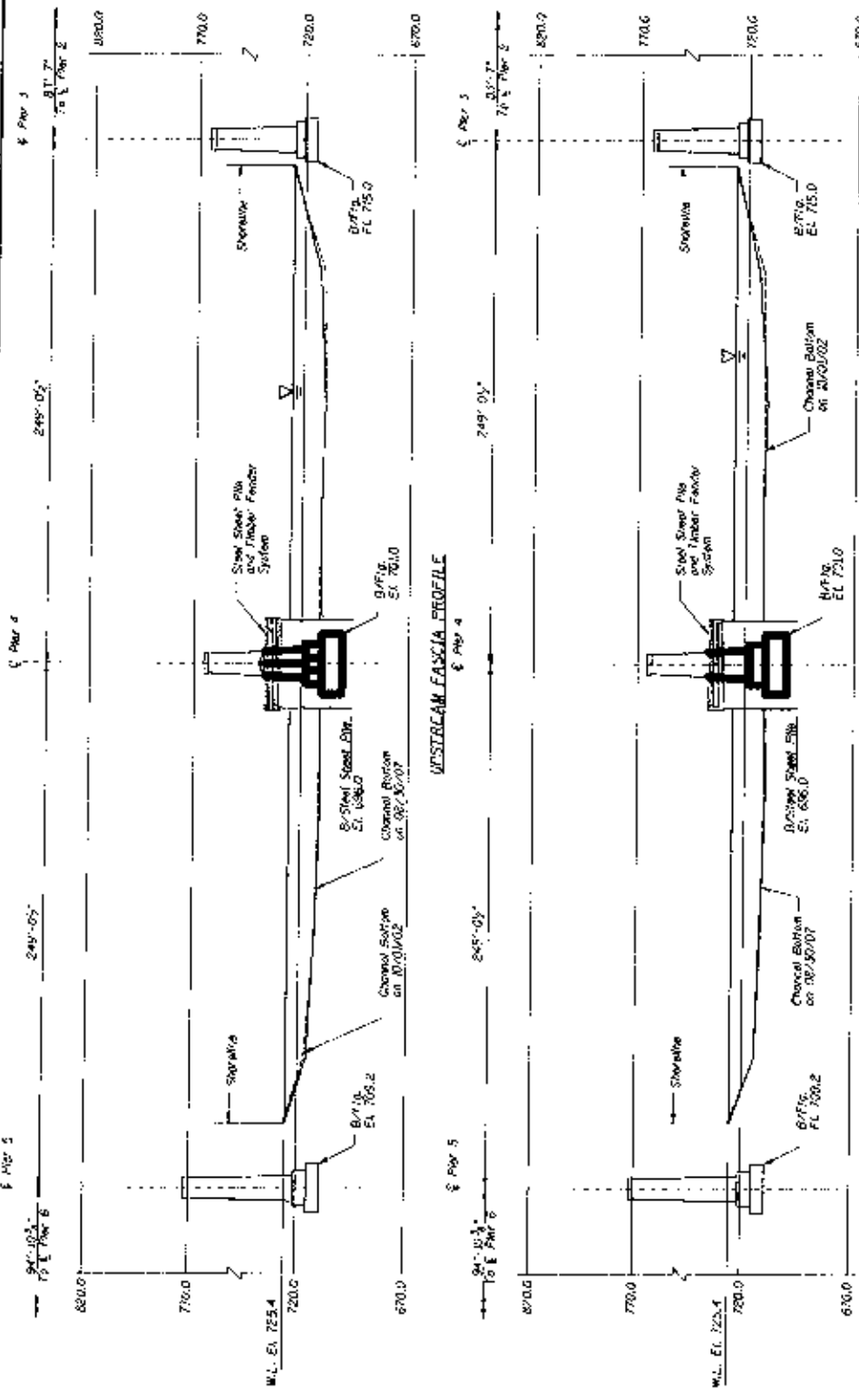

MINNESOTA
 DEPARTMENT OF TRANSPORTATION
 UNDERWATER BRIDGE INSPECTION

STRUCTURE NO. 34248
 OVER THE MISSISSIPPI RIVER
 DISTRICT 5, KENNEPIN COUNTY
 UPSTREAM AND DOWNSTREAM
 FASCIA PROFILES

Collins
 ENGINEERS

Date: Aug 2007
 Scale: 1"=10'
 Figure No. 2

UPSTREAM FASCIA PROFILE

DOWNSTREAM FASCIA PROFILE

Note: Refer to Figure 1 for Section notes.

MINNESOTA DEPARTMENT OF TRANSPORTATION
OFFICE OF BRIDGES AND STRUCTURES
DAILY DIVING REPORT

INSPECTORS: Collins Engineers, Inc. DATE: August 30, 2007
ON-SITE TEAM LEADER: Daniel G. Stromberg, P.E., S.E.
BRIDGE NO: 94246 WEATHER: Sunny, ±65° F
WATERWAY CROSSED: Mississippi River
DIVING OPERATION: _____ SCUBA SURFACE SUPPLIED AIR
_____ OTHER _____

PERSONNEL: Todd Demski, John J. Loftus, Valerie Rouston.
EQUIPMENT: Scuba, U/W Light, Scraper, Probe Rod, Boat, Camera, Fathometer
TIME IN WATER: 10:50 A.M.
TIME OUT OF WATER: 11:45 A.M.
WATERWAY DATA: VELOCITY ±1.0 f.p.s.
VISIBILITY 0.5 feet
DEPTH 14.9 feet maximum at Pier 4

ELEMENTS INSPECTED: Pier 4
REMARKS: Overall, the steel sheet pile encasement construction around Pier 4 was in good condition with uniform moderate corrosion, 1/8 inch scale delamination, and random 1 inch diameter rust nodules with 1/8 inch deep pitting. Above water, the timber fender system was in fair to poor condition with several areas of decay/rot, impact damage, missing members, and failed connections. The above water concrete exhibited random minor areas of section loss having 2 inch maximum penetrations.

FURTHER ACTION NEEDED: _____ YES NO

* Depending on the proposed future use of the structure, consideration can be given to replacing the missing, deteriorated and damaged timber fender components during normal maintenance operations.

Reinspect the submerged substructure unit at the normal maximum recommended (NBIS) interval of five (5) years.

