

ACTION TRANSMITTAL – 2020-30

DATE: September 3, 2020

TO: Transportation Advisory Board

FROM: Technical Advisory Committee

PREPARED BY: Elaine Koutsoukos, TAB Coordinator (651-602-1717)
Joe Barbeau, Senior Planner (651-602-1705)

SUBJECT: Program Year Extension Request: Saint Paul Kellogg Boulevard Bridge

REQUESTED ACTION: Saint Paul requests a program year extension for its Kellogg Boulevard Bridge project (SP# 164-158-025) from fiscal year 2021 to fiscal year 2022.

RECOMMENDED MOTION: That the Transportation Advisory Board approve Saint Paul's program year extension request to move its Kellogg Boulevard Bridge project (SP# 164-158-025) from fiscal year 2021 to fiscal year 2022.

BACKGROUND AND PURPOSE OF ACTION: Saint Paul received \$7,000,000 from the 2016 Regional Solicitation to fund reconstruction of the Kellogg Boulevard bridge from East 7th Street to Market Street (near the RiverCentre and Xcel Energy Center) in program year 2021. The City is requesting an extension of the program year to 2022 as it awaits the results of its request for state funds from the 2020 legislative session.

RELATIONSHIP TO REGIONAL POLICY: The Transportation Advisory Board (TAB) adopted the Program Year Policy in April 2013 and updated it in August 2014 to assist with management and timely delivery of transportation projects awarded federal funding through the TAB's Regional Solicitation. The policy includes a procedure to request a one-year extension based on extenuating circumstances within certain guidelines.

STAFF ANALYSIS: Based on the score on the attached worksheet, staff recommends approval of the program year extension to 2022.

The project is on track for completion in terms of milestones. Existing right-of-way is adequate and construction plans and environmental documentation are on track to be completed by December of 2020. The request has been submitted because the city is requesting state funds from the 2020 legislative session. The request includes a scoresheet, scored by MnDOT Metro District's State Aid office, that tracks progress. The minimum score of seven points was achieved on this request.

It is important to note that an extension of the program year does not guarantee federal funding will be available in that year. The project sponsor is responsible for completing the project in the new program year and covering the federal share of the project until federal funding becomes available. At this time the project would be in line for 2024 reimbursement of federal funds, though an earlier reimbursement may occur if funding becomes available. In that case

the program year change would be administered in the annual Transportation Improvement Program (TIP) update and does not require a separate TIP amendment.

COMMITTEE COMMENTS AND ACTION: At its August 20, 2020, meeting the Funding & Programming Committee voted unanimously to recommend approval of the City of Saint Paul's request for a program year extension for its Kellogg Boulevard Bridge project from fiscal year 2021 to fiscal year 2022.

At its September 2, 2020, meeting, the Technical Advisory Committee voted unanimously to recommend approval of the City of Saint Paul's request for a program year extension for its Kellogg Boulevard Bridge project from fiscal year 2021 to fiscal year 2022.

ROUTING

TO	ACTION REQUESTED	DATE SCHEDULED/COMPLETED
TAC Funding & Programming Committee	Review & Recommend	8/20/2020
Technical Advisory Committee	Review & Recommend	9/2/2020
Transportation Advisory Board	Review & Accept	9/16/2020

REQUEST FOR PROGRAM YEAR EXTENSION

For

SP 164-158-025

MSAS 158, FROM W 7TH ST TO MARKET ST IN ST PAUL - RECONSTRUCT BRIDGE # 90378, WALLS,
APPROACH ROADWAYS AND SIGNAL REPLACEMENTS

City of Saint Paul, MN

REQUESTED BY:

Paul Kurtz

Phone: +1-651-266-6203

Email:

Paul.Kurtz@ci.stpaul.mn.us

1. PROJECT BACKGROUND

a. Project Name: Reconstruct Bridge No. 90378 Kellogg Boulevard (MSAS 158), from W 7th St to Market St in Saint Paul, including Retaining Walls and Approach Roadways

b. Location Map: City of Saint Paul, MN (**Figure 1 – Project Location Map**)

c. Sponsoring Agency: City of Saint Paul, MN

d. Other Participating Agencies: N/A

e. Project Description: Reconstruct Bridge No. 90378, walls, approach roadways and replace signals on MSAS 158, From W 7th St to Market St in St Paul

f. Funding Category:
The project is funded with STP funds.

g. Federal Funds Allocated:
Federal funds in the amount of \$7,000,000 have been secured for Fiscal Year 2021.

2. PROJECT PROGRESS

a. Project Schedule:

The list below outlines the project schedule from preparation of preliminary plans to approval of project memorandum to approval of final plans for construction. The dates highlight current status and upcoming milestones for the project without the program year extension.

Activity / Milestone Date Completed

Design - Conceptual Layouts Completed – May 2020
ROW Certs #1A Completed – June 2020
Design – Preliminary Bridge Plans Submit/Approve – July/August 2020
Design – 30% Preliminary Layouts Underway – October 2020
Design - Draft Project Memorandum – November 2020
Design - Project Memorandum Approval – December 2020
Design – 60% Plan Layouts – December 2020
Design – 90 % Plan Layouts – March 2021
Final Plans Approval and Authorization – June 2021
Project Bid Opening – September 2021
Desired Construction Start – October 2021

b. Right of Way Acquisition:

The City has issued Right of Way Certification No. 1A certifying that existing Right of Way is adequate to facilitate construction of the Project.

c. Plans:

The project involves the reconstruction of the Eastbound Kellogg Bridge No. 90378 at RiverCentre. The bridge is approximately 1000 feet long and carries two eastbound lanes on Kellogg Boulevard between W. 7th Street and Market Street. The bridge spans over the Exchange Street viaduct, which carries one lane of traffic in each direction. Additionally, the Xcel Energy/RiverCentre Loading Dock Exit Road runs parallel to the Exchange Street viaduct underneath the bridge. Commercial delivery vehicles and buses use the Loading Dock Road to exit onto the Exchange Street viaduct.

Adjoining properties add to the complexity of this project. The bridge is situated near or adjacent to major attractions in downtown Saint Paul including Xcel Energy Center, RiverCentre, the Science Museum of Minnesota, RiverCentre Parking Ramp and District Energy Downtown Plant. The City convened a stakeholder meeting in May 2020 and has started the coordination with property owners, facility managers, and utility operators.

30% preliminary plans are current being developed and the plan preparation will be at 60% completion by December 2020. To date, TKDA used a 3D model to check minimum State Aid standards for speed, lane widths, and horizontal and vertical alignments. The City of Saint Paul does not anticipate requesting any variance to meet minimum State Aid requirements.

Attached are plan layout sheets for the City's preferred option including typical sections and profile sheets. **(Figure 2 – Project Layout)**

d. Permits:

Table 1 – Permits required

PERMITS		
Permitting Agency	Required (Y/N)	Permit Status
DNR - Water	No	No DNR properties will be impacted
DNR – Public Waters	No	No DNR properties will be impacted
DNR – Retaining Walls	No	No DNR properties will be impacted
MPCA – NPDES	Yes	City will obtain permit prior to construction
Watershed District	Yes	City will obtain permit prior to construction
Railroad	No	No RR property will be impacted

e. Approvals:

The following is a list of agencies with approval authority and the status of each approval:

Table 2 – Agency Approval Required

AGENCY APPROVAL REQUIRED		
Agency for Approval	Requirement	Status
MnDOT State Aid	Project Memorandum	Approval by December 1, 2020
	Preliminary Plans	Prelim bridge plans due July 2020 30% plans due October 2020 60% plans due December 2020
	Final Plans and Specifications	Approved by June 1, 2021
City of Saint Paul	Conceptual Layouts	Completed – <i>May 2020</i>
	Preliminary Bridge Plans	Complete by July 2020
	30% Plans	Complete by October 2020
	60% Plans	Complete by December 2020
	Final Plans and Specifications	Complete by June 2021

f. Identified Funds Spent to Date on Project:

The City of Saint Paul has encumbered more than \$1 million of local funds to advance the design of this project in 2020. The City will advance local funding to carry out the design and aims to complete all design phase engineering work by June 2021, in anticipation of securing full construction phase funding for this project.

The City of Saint Paul has committed an additional \$2.71 million of local funds in 2021 to complete the design of this project and to gain State Aid approval of final plans and specifications. Since 2018, the City has dedicated staff resources to administer project design and to carry forward its high-priority bonding request at State legislative sessions.

3) Justification for Extension Request:

a) What is unique about this project that requires an extension of the program year?

Bridge No. 90378, originally built in 1936, has served downtown Saint Paul for more than 84 years. As the only remaining load-posted structure on Kellogg Boulevard, the bridge is impeding on the unrestricted movement of freight through downtown. Advancement of steel corrosion and concrete degradation have rendered the bridge structurally deficient. At 84 years old, the bridge is beyond its useful service life and unable to sustain its function in the road transportation network. Recognizing a need for reconstruction, the City of Saint Paul placed the bridge on its 5-year bridge replacement prioritization plan and has since submitted capital funding requests to the State Legislature (beginning in the 2018 session). Currently, the City is requesting State funds for the 2020 legislative session. In the meantime, the City assumed the cost of engineering and design of the bridge and will proceed with design in anticipation of construction funding assistance from the State level.

It is possible that the State funds may be deferred in 2020 and the City will then submit request to the State again in 2021/22. If an extension of the program year is granted, the City of Saint Paul may be able to guarantee full project funding ahead of the 2022 federal authorization.

b) What are the financial impacts if this project does not meet its current program year?

If the project does not meet its current program year, the City will continue to incur a budget shortfall. The City has committed all available local funds to advance the project, but it will not be able to start construction until the funding gap is narrowed. The size and complexity of this bridge, as well as its role in the regional transportation network, places the City in an untenable funding situation without external funding support.

The expected financial impact of program year extension to 2022 is that there may be construction cost escalation to address factors including inflation, changes in labor and industry, or material cost changes due to the introduction of tariffs or resource availability. In recent prior years the City has estimated an annual escalation rate of 3.5%. Increased construction cost will add to the project funding shortfall.

c) What are the implications if the project does not obtain the requested extension?

Without obtaining the requested program year extension, financing the project in its program year will not be feasible and Federal funding will be forfeited, placing the City in an even less manageable position to reconstruct the bridge, which is a core component of Kellogg Boulevard and a major key to providing continued access to major Saint Paul attractions. The City must rely on leveraging all available Federal (and State) funds to accomplish the Project

d) What actions will the agency take to resolve the problems facing the project in the next three to six months?

The project follows an aggressive design schedule. Our goal is to continue to work with MnDOT to deliver final plans and specifications by June 1, 2020. In terms of the project schedule, the City of Saint Paul issued a design RFP at the beginning of this year and had an agreement in force with its design consultant TKDA on April 1, 2020. TKDA immediately developed multiple alternative plans for review and comments by City traffic engineers, roadway engineers and transportation planning group.

In May 2020, the City narrowed the concept plans to two main options and Bridge Division held its first key stakeholder meeting (virtual) to discuss the vision and gather information about logistical and operational needs of nearby facilities. TKDA presented their 3D model of the proposed bridge.

In June 2020, TKDA completed plan layouts for the City's preferred option and compiled preliminary cost estimate for the project. The design of the project is on schedule to deliver 30% plans to Metro State Aid in July 2020 and 60% plans in December 2020.

The following activities have been planned and scheduled to occur in the next few weeks and months:

1. Soil boring and environmental investigations – June 2020 through July 2020
2. Topographic survey work of project area – June 2020 through July 2020
3. Utility locates and verification – June 2020
4. Obtain ROW Certificates – June 2020
5. Bridge Preliminary Plans Approved – July 2020
6. Stakeholder Coordination – Ongoing
7. 30% plans to Metro State Aid – October 2020
8. 60% Plans to Metro State Aid – December 2020
9. Design Project Memorandum Approved – December 1, 2020

The City and its design consultant in partnership with stakeholders, Metro State Aid, and City Public Works will strive to remain on schedule for completing design for this project.

Regional Program Year Policy

TAB Adopted: April 17, 2013

Administrative Modifications: August 20, 2014

Attachment 1: Progress Schedule for Program Year Extension

Enter request date
FRIDAY JUNE 26, 2020

INSTRUCTIONS:

1. Check status of project under each major heading.
2. Enter dates as requested for each major heading.
3. Enter points as suggested by each applicable response.
4. Total points received in the TOTAL POINTS line on the last page. **The minimum score to be eligible to request an extension is seven points.**

ENVIRONMENTAL DOCUMENTATION

PROJECT MEMORANDUM

_____ Reviewed by State Aid If checked enter 4. _____

Date of approval _____

_____ Completed/Approved If checked enter 5. _____

Date of approval _____

_____ EA

_____ Completed/Approved If checked enter 2. _____

Date of approval _____

EITHER

_____ Not Complete

Anticipated Date of Completion December 1, 2020 1

If prior to January 31 of the program year, enter 1. _____

OPPORTUNITY FOR PUBLIC HEARING (not necessary for project memorandum)

_____ Completed

Date of Hearing _____ If checked enter 2. _____

_____ Not Complete

Anticipated Date of Completion _____

If prior to February 28 of the program year, enter 1. _____

FINAL ENVIRONMENTAL ASSESSMENT (not required for project memorandum)

_____ Completed/FONSI Approved If checked enter 2. _____

Date of approval _____

_____ Not Complete

Anticipated Date of Completion _____

If prior to March 31 of the program year, enter 1. _____

STUDY REPORT (required for Environmental Assessment Only)

_____ Complete/Approved If checked enter 1. _____

Date of Approval _____

_____ Not Complete

Anticipated Date of Completion _____

Regional Program Year Policy

TAB Adopted: April 17, 2013

Administrative Modifications: August 20, 2014

CONSTRUCTION PLANS

_____ Completed (includes signature of District State Aid Engineer)
Date _____ If checked enter 3. _____
_____ Completed (approved by District State Aid as to SA Standards but not signed) 2
Date December 2020 If checked enter 2. _____
_____ Not Complete
Anticipated Date of Completion _____
If prior to June 30 of the program year, enter 1. _____

RIGHT OF WAY ACQUISITION

_____ Completed (includes approval of R/W Cert. #1 or #1A) If checked enter 2. 2
Date June 2020 _____
_____ Not Complete
Anticipated Date of Completion _____
If prior to December 31 of the year following the original program year, enter 1. _____

ENGINEERS ESTIMATE OF COSTS

_____ Completed May 2020 If checked enter 2. 2
Date _____
_____ Not Complete
Anticipated Date of Completion _____
If prior to December 31 of the year following the original program year, enter 1. _____

AUTHORIZED

Anticipated Letting Date September 1, 2021
Anticipated letting date must be prior to June 30
in the year following the original program year,
so that authorization can be completed prior to
June 30 of the extended program year.

7

TOTAL POINTS

FIGURE 1 - PROJECT LOCATION MAP

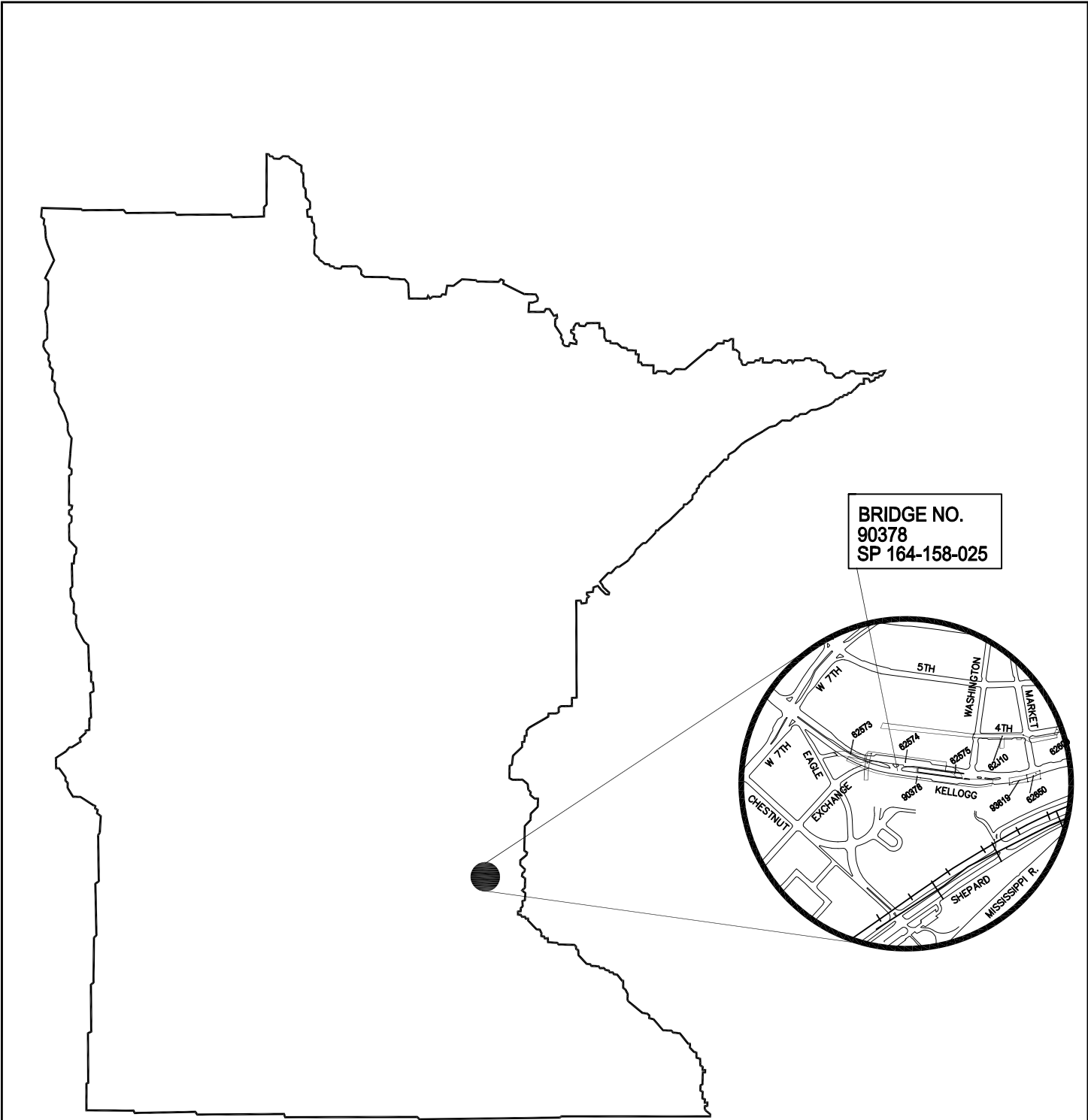

**BRIDGE NO.
90378
SP 164-158-025**

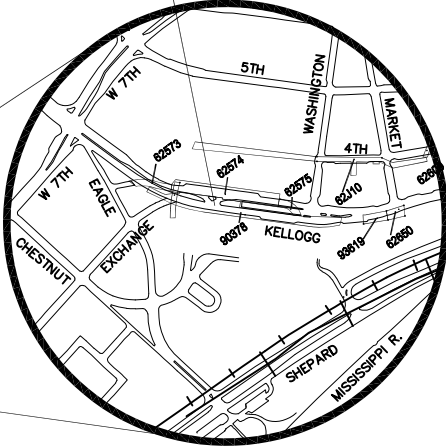

NOT TO SCALE

Z:\bridges\dwgs\B1212 EB kellogg Bridge no. 90378 @ river Centre\Financing\Federal Extension Request\location-map.dwg Jun 19, 2020 - 9:05am



DESIGNED
DGN CHECK
DRAWN
DWG CHECK

PREPARED BY **BRIDGE DIVISION** FOR THE CITY OF ST. PAUL, DEPARTMENT OF PUBLIC WORKS
EASTBOUND KELLOGG BOULEVARD
BRIDGE NO. 90378
STATE LOCATION MAP

STATE AID
PROJECT NUMBER:
S.P. NO. 164-158-025
CITY PROJECT NO.:
B-1212
DATE: 06/19/2020
PAGE:



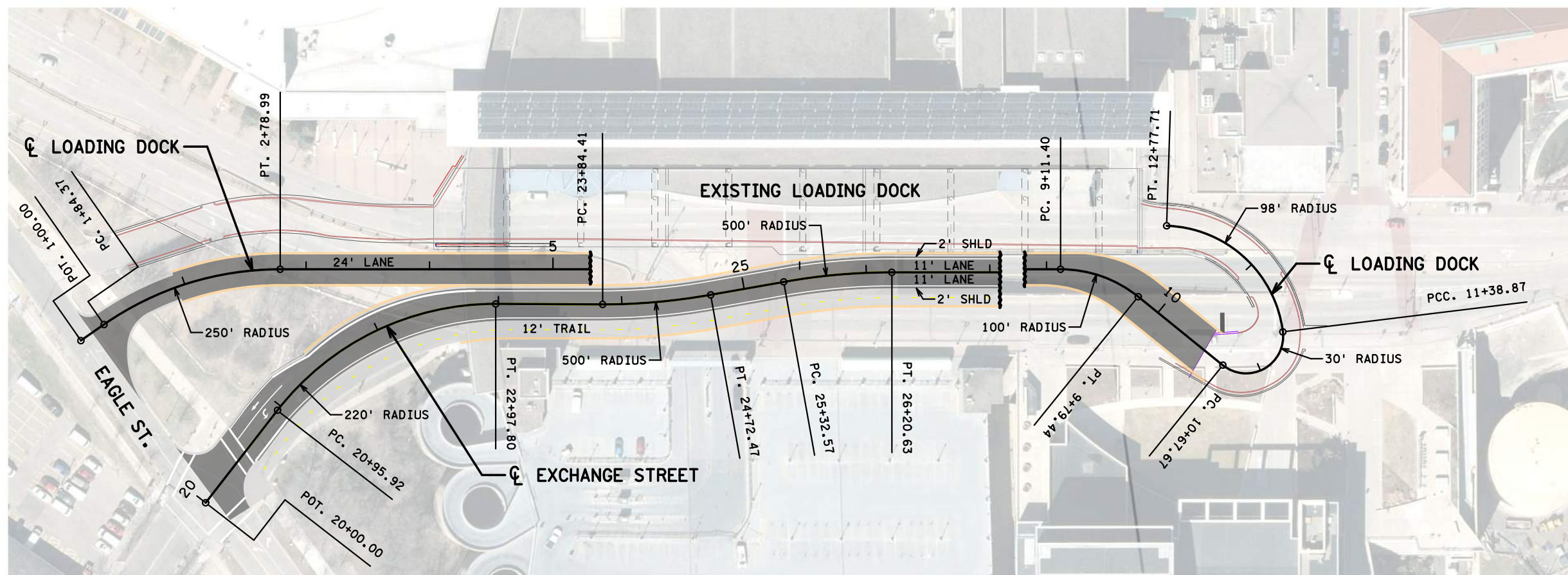
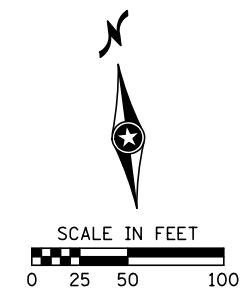
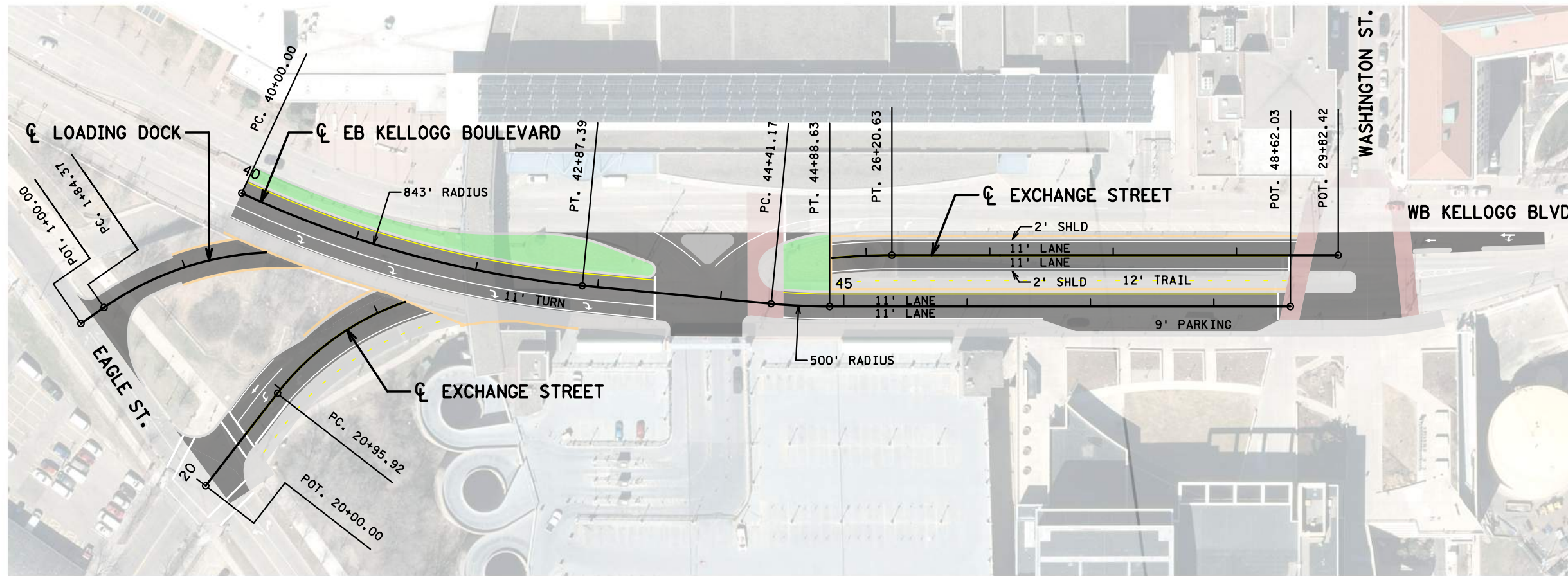

DATE: 6/18/2020 TIME: 6:50:52 PM
 FILENAME: ...Concept_B_Plan.dgn



CITY OF SAINT PAUL

EB KELLOGG BLVD. BRIDGE REPLACEMENT

PLAN LAYOUT

DATE: 6/18/2020 TIME: 7:09:26 PM
FILENAME: ..\Concept_B_Plan_Tsl.dgn

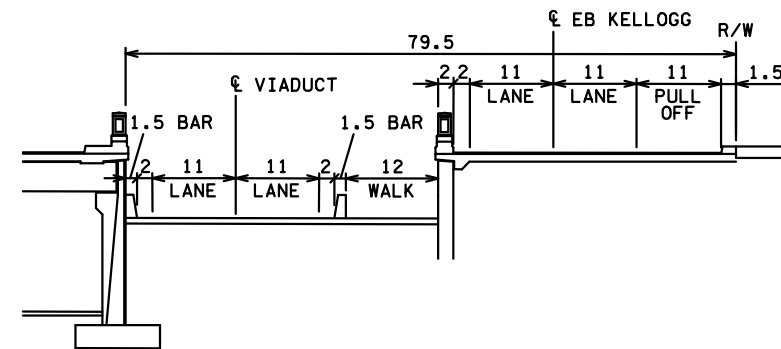
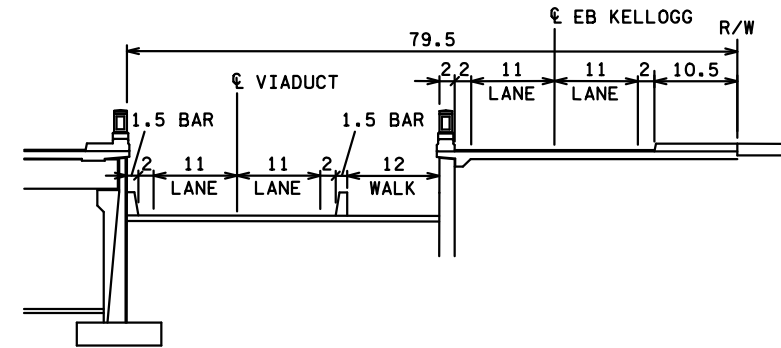
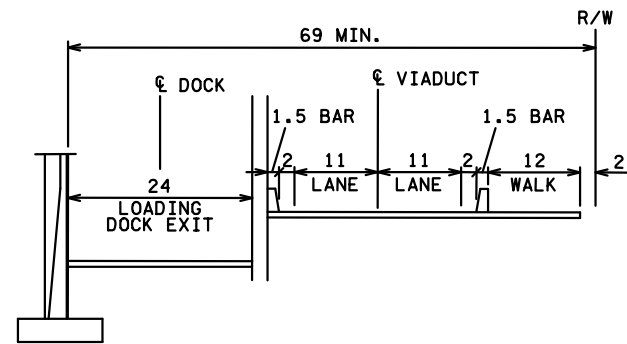

EXCHANGE STREET (VIADUCT) PROFILE

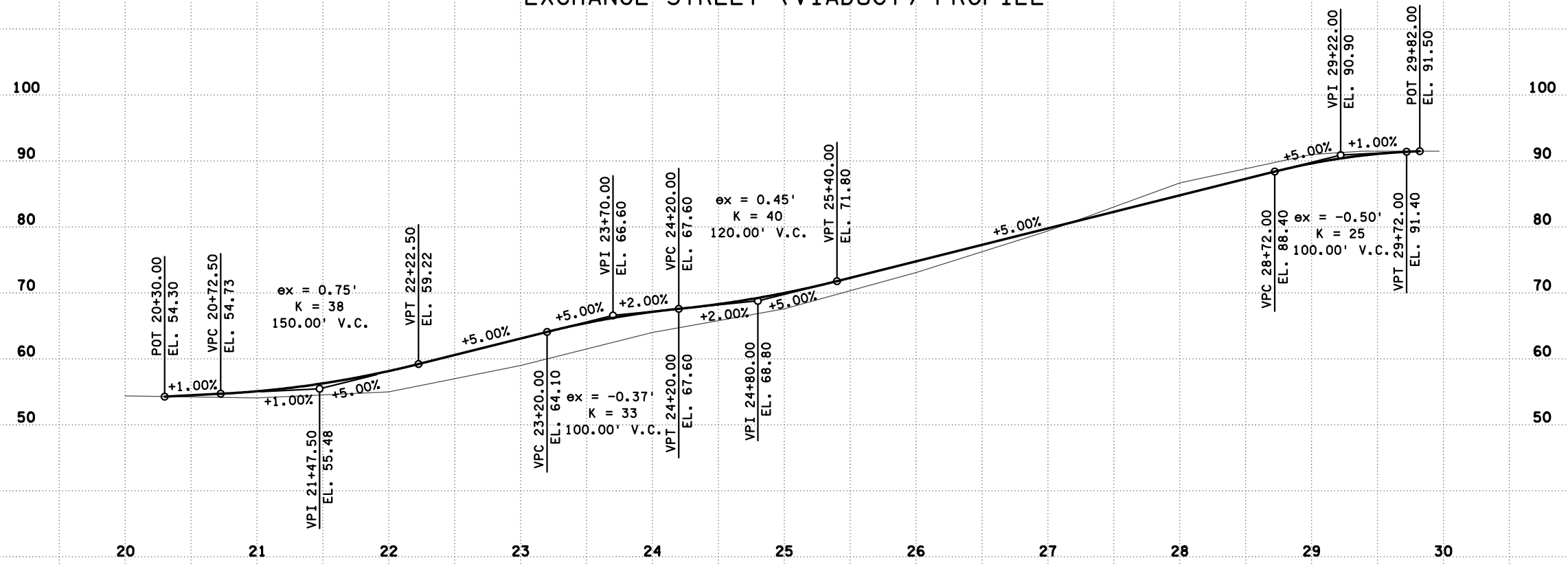

LOADING DOCK PROFILE

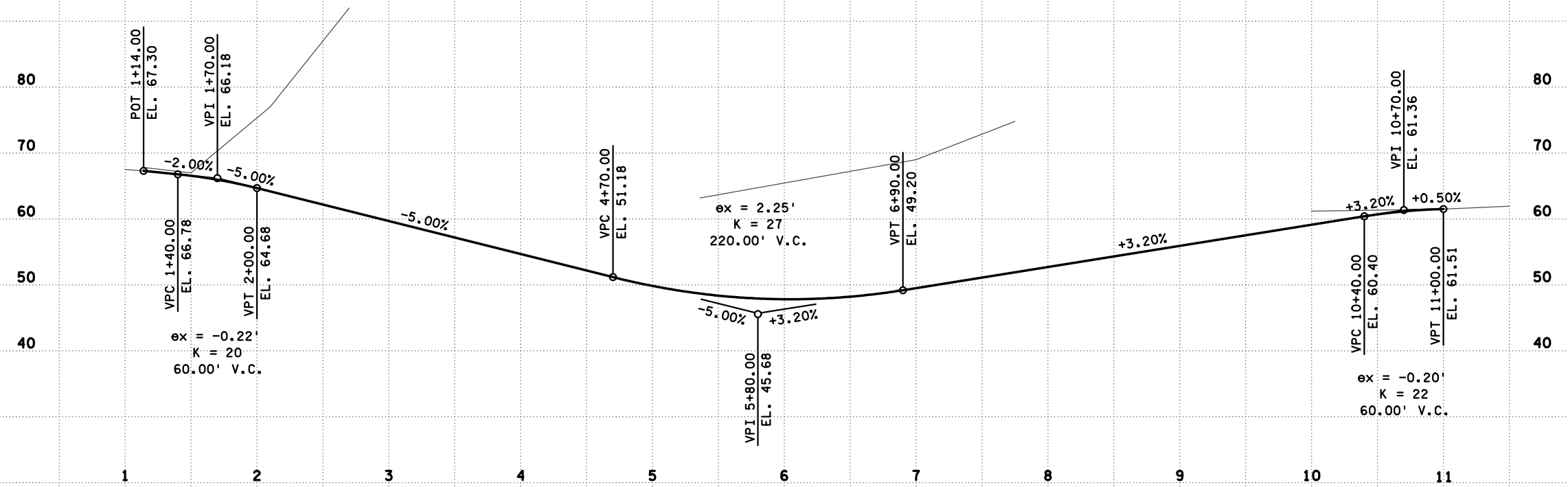

DATE: 6/18/2020 TIME: 2:46:17 PM
 FILENAME: ...Concept_B_Profile.dgn



Transportation Advisory Board Regional Program Year Policy

- The Regional Program Year Policy is intended to manage the development and timely delivery of transportation projects awarded federal funds through the TAB's Regional Solicitation Process.
- Project sponsors awarded federal funds through the regional solicitation process are expected to get their project ready for authorization in their program year.
- The program year is July 1 to June 30 of the year in which the project is originally programmed in the Transportation Improvement Program (TIP).
- By April 1 of the program year, the project must meet the criteria on the attached sheet.
- Additionally, if a regionally selected project is not ready to request authorization by June 15 of its program year, the project will not be carried over into the new TIP unless the project sponsor receives a program year extension from the TAB.
- Project sponsors that have made significant progress but are delayed by circumstances that prevent them from delivering their projects on time must submit a request for a program year extension to the TAB Coordinator by December 31 of the project's program year.
- The maximum length of a program year extension is one year. Projects are eligible for only one program year extension request.
- If a program year extension is granted, funding the project will be contingent on the availability of federal funds. A project sponsor is responsible for funding the project until federal funding becomes available.
- Projects receiving program year extensions will not receive an inflationary cost increase in their federal cost caps.
- "Procedure to Request a Program Year Extension" is provided as Attachment 1.

CRITERIA FOR MEETING PROGRAM YEAR

Construction Projects through the FHWA Process:

- Environmental document approved – April 1
 - *Environmental Documentation draft submittal due December 1*
- Right of way certificate approved –April 1
 - *Condemnation proceedings formally initiated by February 28 with title and possession by June 1.*
- Final construction plans submitted and reviewed for standards, eligibility, funding and structural design – April 1
- Engineer's estimate – April 1
- Utility relocation certificate – April 1
- Permit applications submitted – April 1

Construction Projects through the FTA Process

- Environmental document completed; project plans complete and reflect the project that was selected
- Letting date can be set within 90 days
- FTA notification that grant approval imminent

Right of Way Only Projects through FHWA Process

- Environmental document approved – April 1
- OCPPM/SALT authorization to proceed – June 1

Right of Way Only Projects through FTA Process

- Environmental document completed
- Appraisals over \$250,000 approved by FTA; under \$250,000 reviewed by Right of Way Section
- FTA notifies that grant approval is imminent
- OCPPM transfers funds
- Offers made/condemnation initiated if offers refused

Program Project

- Grant application submitted to FTA; includes work plan
- Notification from FTA that grant approval is imminent
- Work will begin within 90 days after grant approval
- Agreement executed between MnDOT and proposer once funds are transferred

TRANSPORTATION ADVISORY BOARD PROCEDURE TO REQUEST A PROGRAM YEAR EXTENSION

If it appears that a project cannot meet the deadline for authorization within its program year and a program year extension is necessary, the project sponsor must demonstrate to the Funding and Programming Committee that significant progress has been made on the project and the program year criteria can be met within the requested one-year time extension. Projects may be granted only one program year extension. Requests for a program year extension must be submitted by December 31 of the project's program year.

The answers provided on the Progress Schedule for Program Year Extension on Attachment 1 will determine whether a project is **eligible** for a one-year extension. In addition to responding to the Progress Schedule for Program Year Extension, the project sponsor must submit the following materials to the Funding and Programming Committee so it can determine if a program year extension is reasonable:

- 1) Project Background (will be provided by TAB Coordinator).
- 2) Project Progress:
 - a) Complete attached progress schedule with actual dates.
 - b) Right of way acquisition - provide map showing status of individual parcels.
 - c) Plans - Provide layout and discussion on percent of plan completion.
 - d) Permits - provide a list of permitting agencies, permits needed and status.
 - e) Approvals - provide a list of agencies with approval authority and approval status.
 - f) Identify funds and other resources spent to date on project.
- 3) Justification for Extension Request:
 - a) What is unique about this project that requires an extension of the program year?
 - b) What are the financial impacts if this project does not meet its current program year?
 - c) What are the implications if the project does not obtain the requested extension?
 - d) What actions will the agency take to resolve the problems facing the project in the next three to six months?

PROCESS AND ROLES

The Funding and Programming Committee will hear all requests for extensions. The Committee's recommendation will be forwarded to the TAC and TAB for action. The requests will be presented to the TAB for action on its consent agenda. Staff for the Funding and Programming Committee will notify the applicant of the committee's decision.

Adopted by the Transportation Advisory Board

April 17, 2013

STUDY REPORT (required for Environmental Assessment Only)

Complete/Approved If checked enter 1. _____
Date of Approval _____
 Not Complete
Anticipated Date of Completion _____

CONSTRUCTION PLANS

Completed (includes signature of District State Aid Engineer)
Date _____ If checked enter 3. _____
 Completed (approved by District State Aid as to SA Standards but not signed)
Date _____ If checked enter 2. _____
 Not Complete
Anticipated Date of Completion _____
If prior to June 30 of the program year, enter 1. _____

RIGHT OF WAY ACQUISITION

Completed (includes approval of R/W Cert. #1 or #1A) If checked enter 2. _____
Date _____
 Not Complete
Anticipated Date of Completion _____
If prior to December 31 of the year following the original program year, enter 1. _____

ENGINEERS ESTIMATE OF COSTS

Completed If checked enter 2. _____
Date _____
 Not Complete
Anticipated Date of Completion _____
If prior to December 31 of the year following the original program year, enter 1. _____

AUTHORIZED

Anticipated Letting Date _____.
Anticipated letting date must be prior to June 30
in the year following the original program year,
so that authorization can be completed prior to
June 30 of the extended program year.

TOTAL POINTS _____