

**ACTION TRANSMITTAL No. 2014-22**

**DATE:** February 21, 2014  
**TO:** Technical Advisory Committee  
**FROM:** TAC Funding and Programming Committee  
**PREPARED BY:** Heidi Schallberg, Senior Planner (651-602-1721)  
**SUBJECT:** Scope Change Request for the Crystal Lake Regional Trail in Robbinsdale  
**REQUESTED ACTION:** Three Rivers Park District requests a scope change to modify the scope of SP#091-090-075 to increase the length by 0.4 miles, change the trail alignment, eliminate three bridges, change approximately 0.5 miles of the project from off-road trail to on-street facility with shared lane markings, and move the regional trail head facilities. The change would reduce the budget to a total of \$2,600,000 with \$1,840,000 in Surface Transportation Program (STP) funds (less than the \$2,163,200 originally programmed) and an increased local amount of \$760,000.  
**RECOMMENDED MOTION:** Recommend approval of the request to modify the scope for the Crystal Lake Regional Trail as described above with the addition of some type of pedestrian accommodations in an 800' section where there are no existing sidewalks.

**BACKGROUND AND PURPOSE OF ACTION:** In the 2009 solicitation, the Three Rivers Park District received \$2,163,200 in Surface Transportation Program (STP) funding for the Robbinsdale segment of the Crystal Lake Regional Trail. The project is programmed in 2014. The scope change request and supporting information are attached. A related TIP amendment request has also been submitted.

**RELATIONSHIP TO REGIONAL POLICY:** Projects that receive funding through the regional solicitation process are subject to the regional scope change policy. The purpose of this policy is to ensure that the project is designed and constructed according to the plans and intent described in the original application. Additionally, federal rules require that any federally-funded project scope change must go through a formal review and TIP amendment process if the project description or total project cost changes substantially. The scope change policy and process allow project sponsors to make adjustments to their projects as needed while still providing substantially the same benefits described in their original project applications.

**STAFF ANALYSIS:** Staff reviewed the submitted scope change request. The trail project originally scored 791 points and was ranked 2<sup>nd</sup> out of the seven applications in this category. It was the second of two funded projects for STP in the Bike Walk category. Based on a review of the original application, the proposed scope changes would not have been likely to considerably change the project score. Additional

considerations could include that a segment of the new alignment that may not include sidewalks, changing the project from a consistent multimodal trail connection to an on-street connection only for bicycles for a segment. The crossing at CSAH 81 and 40<sup>th</sup> Ave N. would also increase the number of lanes pedestrians and bicyclists would need to cross (appears to be five lanes) compared to the original two-lane crossing proposed. Detailed scoring notes were not available for this project from the 2009 solicitation. Based on the information provided, staff recommends approval of the requested scope change.

**COMMITTEE COMMENTS AND ACTION:** At its February 20, 2014, meeting, the Funding and Programming Committee discussed the scope change request and concerns about an 800' section that does not include existing sidewalks. Under this scope change request, this section would change to on-street shared lane markings for bicycles, eliminating the multi-use trail in this section. The committee discussed the project as a regional trail and potential ways this section could be addressed, including striping and wayfinding. The committee's recommendation to approve the scope change request is contingent on the project sponsor adding some type of pedestrian accommodations to address this section before the TAC meeting. Additional information has been provided by the Three Rivers Park District to address the request from the Funding & Programming Committee.

---

**ROUTING**

<b>TO</b>	<b>ACTION REQUESTED</b>	<b>DATE COMPLETED</b>
TAC Funding & Programming Committee	Review & Recommend	February 20, 2014
Technical Advisory Committee	Review & Recommend	
Transportation Advisory Board	Review & Approve	

January 23, 2014

**Three Rivers  
Park District  
Board of  
Commissioners**

Penny Steele  
District 1

Mr. Karl Keel, PE  
TAC Funding and Programming Committee  
1700 West 98th Street  
Bloomington, Minnesota

Jennifer DeJournett  
District 2

**SUBJECT: CRYSTAL LAKE REGIONAL TRAIL- ROBBINSDALE SEGMENT, ROBBINSDALE,  
MINNESOTA – SCOPE CHANGE REQUEST**

Dear Mr. Keel:

Daniel Freeman,  
Vice Chair  
District 3

### **INTRODUCTION**

John Gunyou,  
Chair  
District 4

Three Rivers Park District was successful in the 2009 federal funding solicitation of the Bikeways/Walkways category for development of the Crystal Lake Regional Trail-Robbinsdale Segment. The State Transportation Improvement Program (STIP) has \$2,163,200 in federal funding (total project cost of \$2,704,000) scheduled for improvements within the City of Robbinsdale in fiscal year 2014 (see Attachment A, Figure 1: Project Location Map). Although the original project description has changed since the original submittal, the benefits have remained consistent with its original intent. Therefore, the Park District is requesting a scope amendment in order to move forward with a revised project scope. Please consider this formal request from Three Rivers Park District for the change in scope for the development of Crystal Lake Regional Trail-Robbinsdale Segment for fiscal year 2014

John Gibbs  
District 5

Larry Blackstad  
Appointed  
At Large

### **ORIGINAL PROJECT DESCRIPTION**

Steve Antolak  
Appointed  
At Large

In the 2009 STP funding submittal, the scope of Crystal Lake Regional Trail –Robbinsdale Segment was identified as the construction of two new miles of off-road regional trail within the City of Robbinsdale, connecting the existing Minneapolis Grand Rounds regional trail network at the southern project terminus to the existing Twin Lakes Regional Trail tunnel under Trunk Highway 100 at the northern project terminus. The Park District also planned on the development of a regional trail head in Lakeview Terrace Park, as well as three bridges over planned storm water treatment facilities. The overall objective of the development of the Crystal Lake Regional Trail

Cris Gears  
Superintendent

- Robbinsdale Segment is to improve safety, speed and attractiveness of bicycle commuting by connecting to the regional trail system in Minneapolis north to the Twin Lakes Regional Trail into Crystal and Brooklyn Park, as well as provide the connecting link to the northern portion of the Crystal Lake Regional Trail in Elm Creek Park Reserve.

## **REQUESTED CHANGE OF SCOPE**

Subsequent to submitting the STP funding submittal, the Park District completed a master plan for the development of Crystal Lake Regional Trail from Minneapolis to Elm Creek Park Reserve in Maple Grove. Through this planning process, the selected alignment of the trail deviated from the alignment presented in the STP submittal. Most notably, the need for pedestrian bridges within Lakeview Terrace Park was eliminated as the final location of the storm water treatment facilities (Attachment B, Figure 3), which does not interfere with the proposed trail alignment, and reaffirms that the proposed trail is intended to be on street in a shared configuration with the low volume section of Lakeland Avenue between Lake View Terrace Park and 40th Avenue (Attachment B, Figures 4 and 5). An on street alignment in this location was selected due to the significant impacts an off road trail would have to private property at this location. It is proposed that Shared Lane Markings (SLMs), or "Sharrows," be used to indicate a shared lane environment for bicycles and automobiles on this local street. One other alignment change indicated in the master plan showed the trail traveling along the north side of Spanjers Park along Lake Drive /CSAH 9 to the controlled intersection of CSAH 81 (Attachment B, Figure 6).

Early stages of the final design for this portion of the trail also included refinements to the route alignment that differ from the STP funding submittal. Through direction from the Robbinsdale City Council, the portion of the trail that was to traverse the wooded area north of Lakeview Terrace Park was modified to follow the shoreline on a boardwalk to create a connection to the lake until merging with the CSAH 81 alignment to avoid crossing a large storm sewer outlet (Attachment B, Figure 4). In addition, design refinements suggest that it is more appropriate to have the trail cross CSAH 9 at Lake Road, which requires the trail to then follow the north side of CSAH 9 from Lake Road to Lakeland Avenue (Attachment B, Figure 6) where, due to private property constraints, the trail would once again be located on street in a shared configuration with the low volume Lakeland Avenue from CSAH 9 north to the Twin Lakes boat launch area and intersection with Twin Lakes Regional Trail (Attachment B, Figure 7).

Since the STP submittal, Hennepin County has also constructed approximately 2.5 miles of Crystal Lake Regional Trail in the Cities of Crystal and Brooklyn Park. Through local funding, Three Rivers Park District has included a section of additional trail from the Twin Lakes Regional Trail underpass of TH 100 to 47<sup>th</sup> Avenue to connect to the existing section of Crystal Lake Regional Trail (Attachment B, Figure 8).

During the design process, it was also determined that it would be appropriate to locate the trail head parking and restroom facilities to the Twin Lakes boat launch area instead of Lakeview Terrace Park as indicated in the STP funding submittal since parking and other facilities already exist in Lakeview Terrace Park.

## **MODIFIED PROJECT DESCRIPTION AND COST ESTIMATE**

This project consists of the construction of a 10-foot wide, paved, multi-use trail from Victory Memorial Parkway to Twin Lakes Regional Trail tunnel under Trunk Highway 100. Three Rivers Park District under a separate project is also constructing the section of trail from Twin Lakes Regional Trail under Trunk Highway 100 to 47th Avenue North for a total distance of 2.4 miles. The Preferred Alternative provides connections to downtown Robbinsdale and connects Lakeview Terrace Park and Spanjers Park. Attachment B (Figures 1 through 8) illustrates the location of the proposed Crystal Lake Regional Trail – Robbinsdale Segment and existing trails.

From Victory Memorial Parkway, the off-road trail follows Lakeland Avenue to the northwest, parallel to the east side of CSAH 81 (Bottineau Boulevard) along residential neighborhood frontage. The trail route continues along the western boundary of Lakeview Terrace Park and the west side of Crystal Lake via a boardwalk. The trail then connects to Lakeland Avenue where it is located on street in a shared configuration, passing a residential area consisting of multi-family and single-family residential housing to 40th Avenue North, which it crosses at the controlled intersection of CSAH 81 and 40th Avenue.

From this intersection, the trail follows the north side of 40th Avenue North to Lake Road and continues along the west side of Lake Road following the eastern boundary of Spanjers Park to Lake Drive/CSAH 9. The trail continues west along the north side of Lake Drive to Lakeland Avenue (This portion of the trail will be constructed in 2015 as part of a 2014 Hennepin County Road Reconstruction Project and will utilize local funds). The trail follows Lakeland Avenue in an on-street shared configuration to the Twin Lakes boat launch southeast of the CSAH 81/TH 100 interchange. The project will include the construction of trail connections, a trailhead parking, trail kiosks and restroom facilities within the boat launch area. Within the boat launch area, an off-road trail connection will be made to the existing Twin Lakes Regional Trail, which crosses under TH 100 and a connection to trail / tunnel under CSAH 81.

The STIP has \$2,163,200 in federal funding (total project cost of \$2,704,000) scheduled for improvements within the City of Robbinsdale in fiscal year 2014. In order to be consistent with the revised scope and proposed design concept, a more refined construction cost estimate was developed. The revised total project cost estimate is estimated at \$2,600,000. Of this total, \$2,300,000 is for the STP portion of the project, and \$300,000 is for the local portion of the project. Based on updated information and updated details, this cost estimate better represents the proposed improvements associated with the Crystal Lake Regional Trail – Robbinsdale Segment project.

The modified scope and revised design for the Crystal Lake Regional Trail –Robbinsdale Segment project continues to respond to the needs identified in the original application. While project elements have been modified, the benefits remain consistent with its original intent. Hence, responses to the prioritizing criteria do not need to be revised.

We look forward to discussing the revised project with you in more detail. If you have any questions, I can be reached at 763-559-6758.

Sincerely,



THREE RIVERS PARK DISTRICT

Alex Meyer

Landscape Architect/Project Manager

#### Attachments

cc: Colleen Brown, MnDOT  
Heidi Schallberg Met Council  
David Juliff, SRF

**To:** Pat Bursaw, TAC Chair  
Funding and Programming

**From:** David Juliff, PE, LEED AP, Principal

**Date:** February 27, 2014

**Subject:** Crystal Lake Regional Trail (Robbinsdale Segment)  
Additional Information for Amendment Request  
SP# 091-090-075

## Background

This project was part of the agenda for the most recent TAC meeting held on Thursday, February 20, 2014 at the offices of the Metropolitan Council. The discussion was regarding the request by Three Rivers Park District to amend the project for scope and budget. Specifically, there were questions regarding the proposal to eliminate off-street accommodations for pedestrians/bicyclists for approximately 800 feet of the proposed 2.4 mile route. This memorandum provides more detail on the reasons for eliminating the off-street accommodations at this location.

## Existing Conditions

In 2006-2008, Hennepin County reconstructed CSAH 81 (Bottineau Boulevard) which runs parallel and adjacent to the proposed Crystal Lake Regional Trail corridor for the segment in question. (See figures 4 and 5 of the initial Amendment Request for the location of the segment – approximately Station 155+00 to Station 163+00). As part of that project, the East Frontage Road of CSAH 81 was also reconstructed as a 24 foot wide street with a 10' boulevard between CSAH 81 and the East Frontage Road. The project required the acquisition of right of way from several of the most southerly parcels (the condominiums and the five single family homes). Because of the existing conditions and the opposition by the property owners of the condominium and the first single family residential property, sidewalk was not constructed in this section of the corridor (as can be seen from the aerial photo on the graphics referenced above).

For these same reasons, it is the desire of Three Rivers Park District to eliminate the off-road accommodations and utilize the existing low volume street for the pedestrian/bicycle connection in this location. We have provided the following additional information to assist in your review of the Amendment Request:

- Typical Sections from the CSAH 81 Reconstruction Project (Sheet 48 of 713) – Note the width of the frontage road and narrow boulevard between CSAH 81 and the East Frontage Road

- Cross Sections from the CSAH 81 Reconstruction Project (Sheets 660-662 of 713) – Note the significant walls, trees and slopes in the boulevard of the East Frontage Road as well as the steep slope between CSAH 81 and the East Frontage Road
- Photographs (A, B and C) of the existing conditions adjacent to the condominium and first single family home north of the cul de sac) with key dimensions indicated on the images. All photographs are taken with a view to the north (CSAH 81 is on the left of the photos).
- The following is an excerpt from page 61 of the Crystal Lake Regional Trail Master Plan (approved by the Metropolitan Council on December 14, 2011 and adopted by Three Rivers Park District on January 5, 2012) that was prepared by Three Rivers Park District in conjunction with the City of Robbinsdale, Hennepin County, and the Minnesota Department of Transportation: *“The regional trail the(sic) extends along the east side of Lakeland Avenue, passing a residential area consisting of both multi-family and single-family residential. The Park District recognizes Lakeland Avenue’s existing spatial constraints for this segment, and recommends the trail to be on-street until accommodations for an off-street trail option are available.”*

It should also be noted that because this is a cul de sac that serves a total of 13 residential units, it is estimated that the Average Daily Traffic (Vehicular) will be less than 100. Also note the existing sign on Photograph B (City of Robbinsdale Walking Route).

### **Requested Action**

Because of the low volume of traffic, the difficulty in constructing a separated bicycle or pedestrian path/sidewalk in this area, and the existing pedestrian designation, Three Rivers Park District requests approval of the Amendment to the project scope and budget. It is our belief that the impact of constructing a separate facility for pedestrians and/or bicyclists would be significant, yet would not provide a benefit commensurate with those impacts (significant tree and landscaping removal as well as easement acquisition for construction). Additional wayfinding signs and markings will be included in the final plans for the project to provide appropriate guidance to the trail users as well as to provide awareness to those in motorized vehicles.

CC: Alex Meyer, Three Rivers Park District  
Colleen Brown, Minnesota Department of Transportation







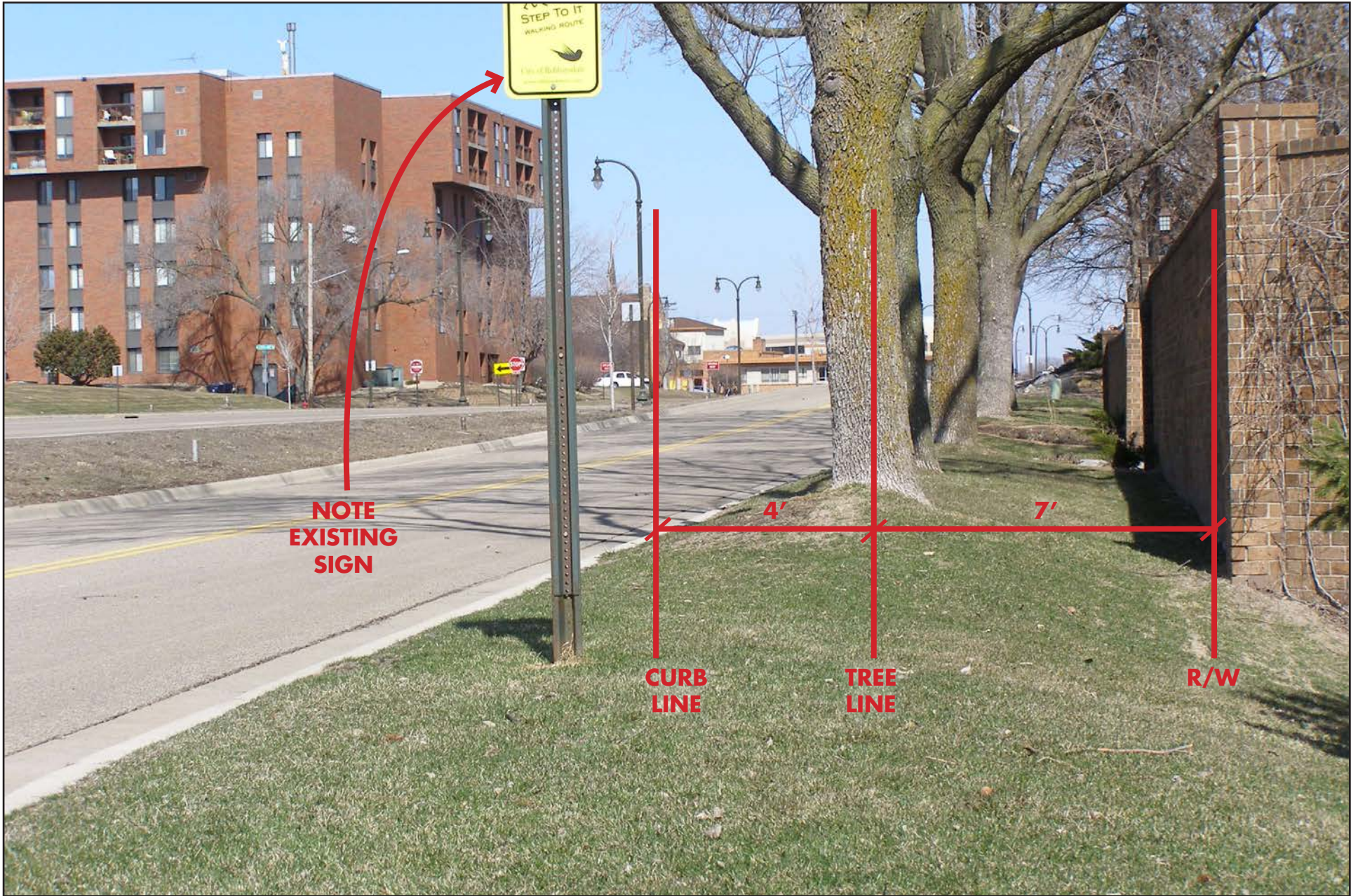



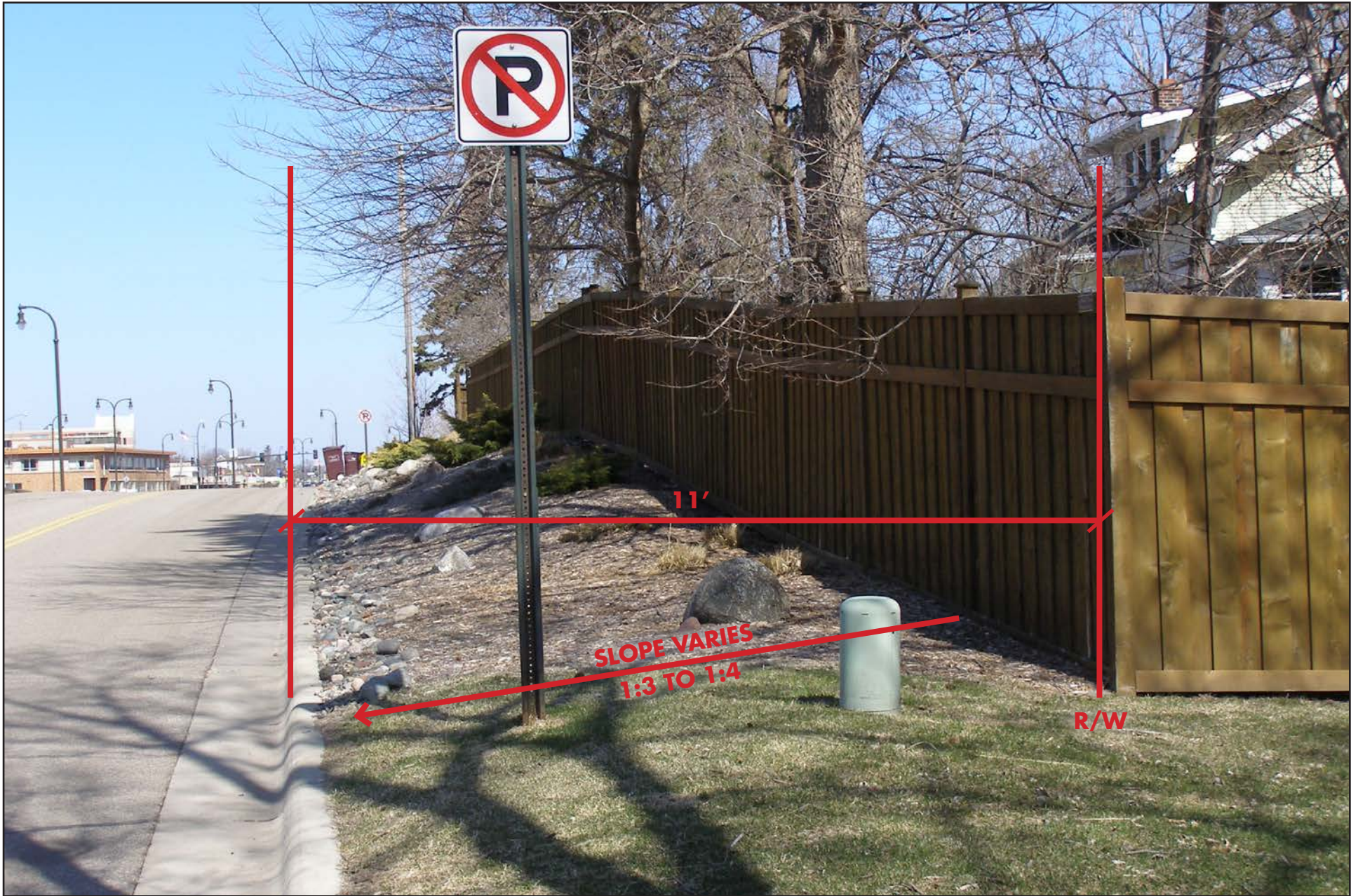



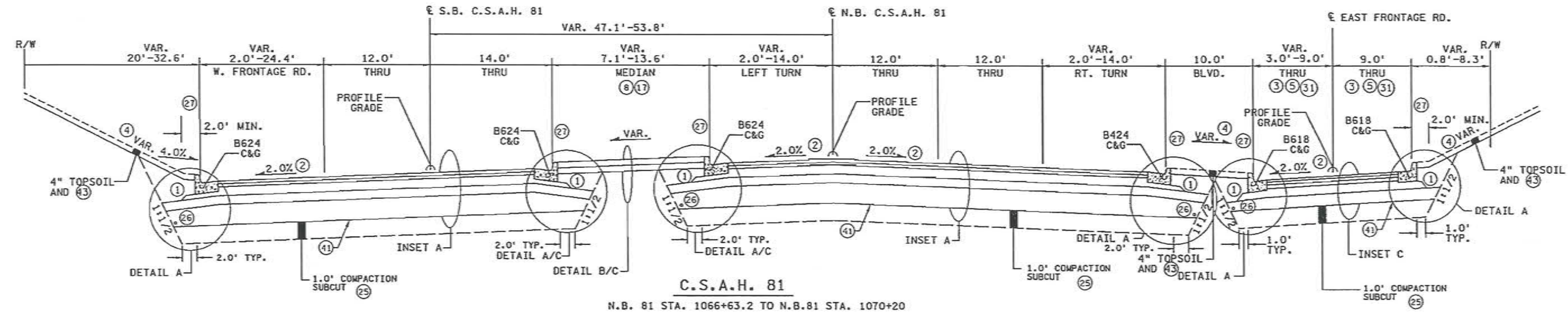
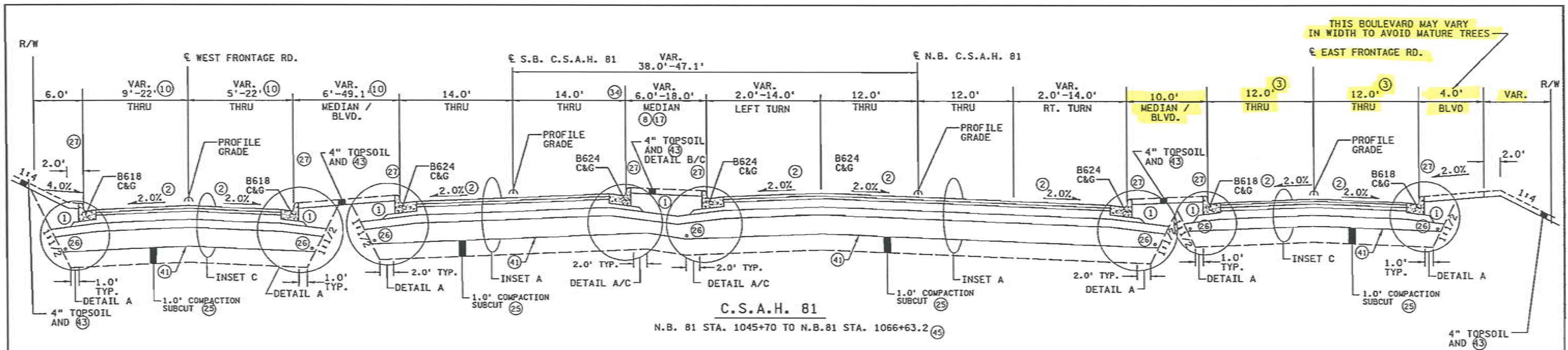

**NOTES:**

- ① BACKFILL WITH SUITABLE GRADING MATERIAL.
- ② CROSS SLOPE VARIES. SEE SUPERELEVATION AND DRAINAGE PLANS FOR LOCATION AND SUPERELEVATION TRANSITION RATE.
- ③ EAST FRONTAGE ROAD NARROWS BETWEEN N.B.81 STA 1066+15.53 TO STA. 1068+80.82 AS IT SERVES AS A DRIVEWAY ACCESS ONLY.
- ④ GRADE BERM / BOULEVARD TO MATCH EXISTING GROUND OR PROPOSED ADJACENT CONSTRUCTION AS SHOWN IN THE CROSS SECTIONS AND AS DIRECTED BY THE ENGINEER.
- ⑤ 8.0' WIDE SIDEWALK WITH VARIABLE OFFSET FROM FACE OF CURB FROM N.B. 81 STA. 1049+96 TO STA. 1056+67.6 AND FROM N.B.81 STA. 1068+80.8 TO STA. 1069+67.8, IN PLACE OF EAST FRONTAGE ROAD, SEE SIDEWALK AND DRIVEWAY CONSTRUCTION PLANS.
- ⑥ MEDIAN SURFACE SHALL BE TREATED AS SHOWN IN THE LANDSCAPE PLANS AND DETAILS.
- ⑩ ONE WAY WEST FRONTAGE ROAD (SLIP) (SOUTHBOUND ONLY) FROM N.B.81 STA. 1062+80.0 TO N.B.81 STA. 1066+63.2. (SEE CONSTRUCTION PLANS)
- ⑰ GRADE MEDIAN AS SHOWN IN THE CROSS SECTIONS AND AS DIRECTED BY THE ENGINEER TO DRAIN.
- ⑳ MNDOT SPEC. 2112 MODIFIED TO A DEPTH OF 1.0' TO BE PAID FOR AS "SUBGRADE EXCAVATION" (CUT SECTION ONLY)
- ㉔ 4" PERFORATED T.P. PIPE DRAIN ALONG THE BOTTOM OUTSIDE LOWER EDGE OF THE SELECT GRANULAR MATERIAL AS SHOWN IN THE DRAINAGE AND UTILITY PLAN AND AS DIRECTED BY THE ENGINEER IN THE FIELD. T.P. PIPE DRAIN TO BE CONNECTED TO THE STORM SEWER SYSTEM.
- ㉗ 1.5' OBSTACLE FREE CLEAR ZONE FROM FACE OF CURB (TYPICAL)
- ㉘ SIDEWALK LOCATION AND DIMENSIONS VARY. SEE SIDEWALK CONSTRUCTION PLAN FOR LOCATIONS AND DIMENSIONS.
- ㉙ CONSTRUCT A 12' WIDE LEFT TURN LANE ADJACENT TO SB THRU LANE BETWEEN N.B.81 STA. 1047+85.9 AND STA. 1050+45.7.
- ㉚ FURNISH & INSTALL GEOTEXTILE FABRIC TYPE V, ONLY AS DIRECTED BY THE ENGINEER IN THE FIELD.
- ㉛ TURF ESTABLISHMENT AS SHOWN IN THE TURF ESTABLISHMENT PLAN AND AS SUPPLEMENTED AND AMENDED IN THE LANDSCAPE PLANS AND DETAILS.
- ㉜ FROM N.B. 81 STA. 1044+00 TO N.B. 81 STA. 1054+00 AN EXTRA 1.0' DEPTH OF SUBGRADE EXCAVATION IS PROVIDED FOR REMOVAL OF POTENTIAL UNSUITABLE SOILS (SEE CROSS SECTIONS). UNSUITABLE SOILS TO BE REMOVED AND REPLACED WITH SELECT GRANULAR BORROW TO THE EXTENT AS DIRECTED BY ENGINEER IN FIELD FOR THIS REGION AND THROUGHOUT THE PROJECT LIMITS. PAYMENT FOR THIS WORK SHALL BE UNDER THE CONTRACT ITEMS "SUBGRADE EXCAVATION" AND "SELECT GRANULAR BORROW".

5:32:09 PM  
 1/17/2006  
 H:\projects\5037\HI-MUP\lan\5037.TSD

NO	DATE	BY	CHK	APPR	REVISION

I hereby certify that this plan, specification, or report was prepared by me or under my direct supervision and that I am a duly Licensed Professional Engineer under the laws of the State of Minnesota.  
 Print Name: MICHAEL R. TURNER  
*Michael R. Turner*  
 Date: 01-05-2006 License # 40120  
 SRF CONSULTING GROUP, INC



STATE AID PROJECT NO. 27-681-23 / M.S.A. 158-020-02  
 COUNTY PROJECT NO. 0117  
 CITY PROJECT NO. 32205

DRAWN BY J.MELVILLE  
 DESIGNED BY M.MOHS  
 CHECKED BY M.TURNER  
 CDWA. NO. 5037

HENNEPIN COUNTY  
 TYPICAL SECTIONS  
 C.S.A.H. 81

SHEET 48 OF 713



NOT ALL EXISTING UTILITIES ARE SHOWN IN THESE CROSS SECTIONS. SEE EXISTING UTILITY TABULATIONS AND TOPOGRAPHY AND UTILITY PLAN SHEETS FOR ALL LOCATIONS. FOR THE LOCATION OF PROPOSED UTILITIES, SEE THE VARIOUS UTILITY PLAN SHEETS AND PROFILES.

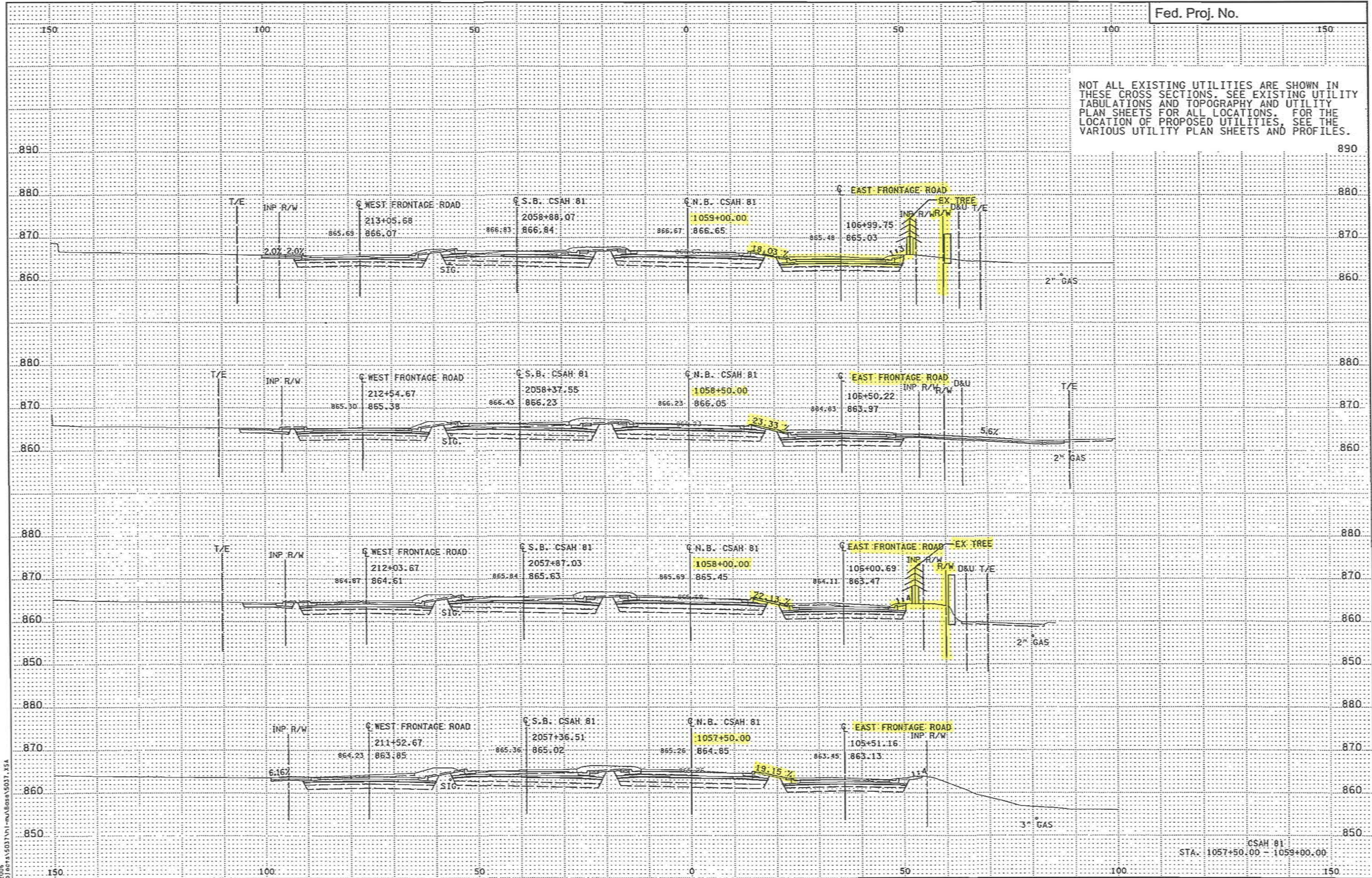

10:48:32 AM  
1/20/2006  
H:\Project\secta\037\N1-mc\Bosh\0037.X5A

CSAH 81  
STA. 1057+50.00 - 1059+00.00



NOT ALL EXISTING UTILITIES ARE SHOWN IN THESE CROSS SECTIONS. SEE EXISTING UTILITY TABULATIONS AND TOPOGRAPHY AND UTILITY PLAN SHEETS FOR ALL LOCATIONS. FOR THE LOCATION OF PROPOSED UTILITIES, SEE THE VARIOUS UTILITY PLAN SHEETS AND PROFILES.



10:48:20 AM  
1/20/2006  
M:\VProj\acra\5037\1-m\Boren\5037.X54



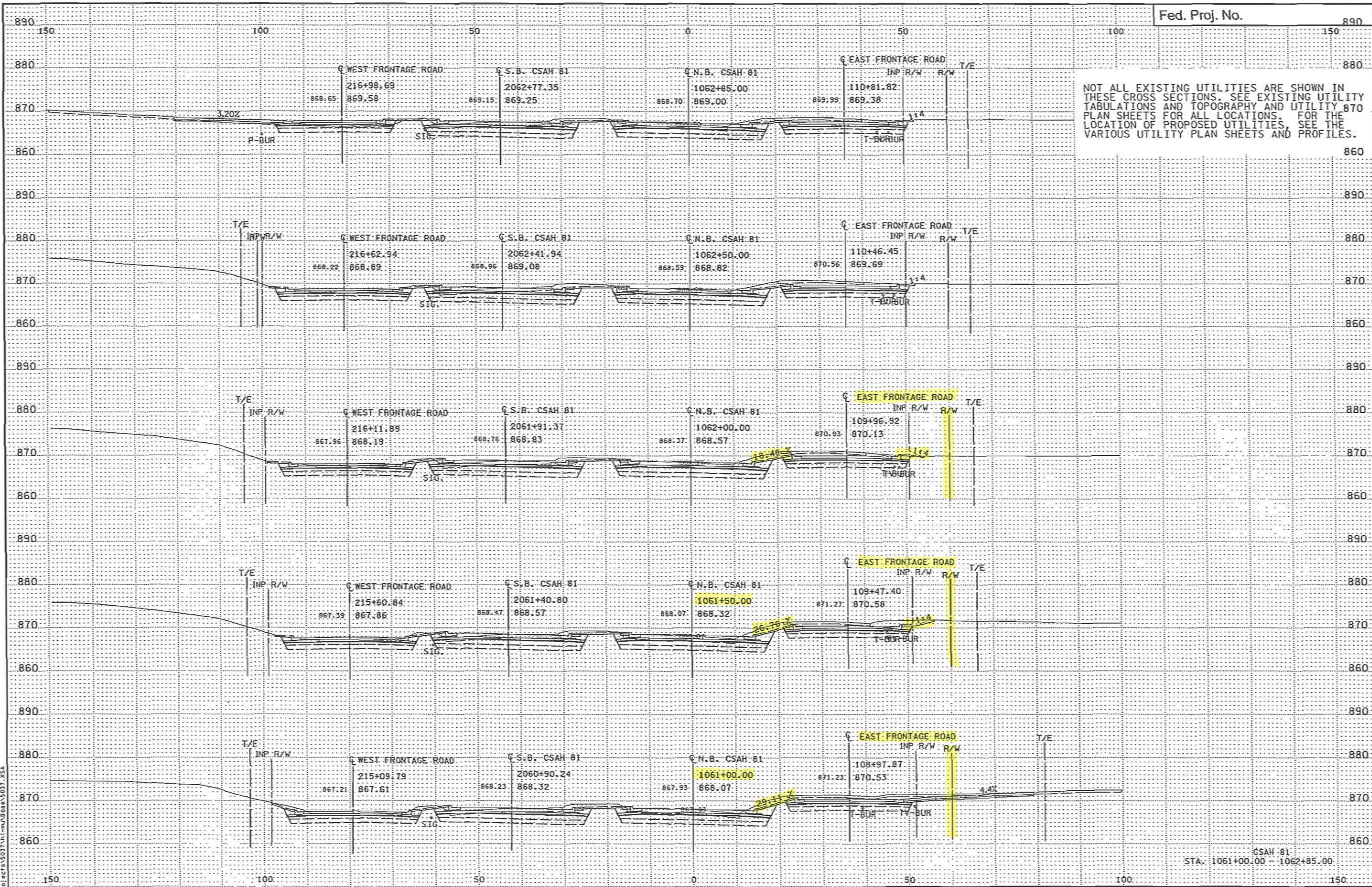

CSAH 81  
STA. 1061+00.00 - 1062+85.00

10:48:05 AM  
1/20/2006  
I:\Projects\5037\11-m\Bases\5037.X54



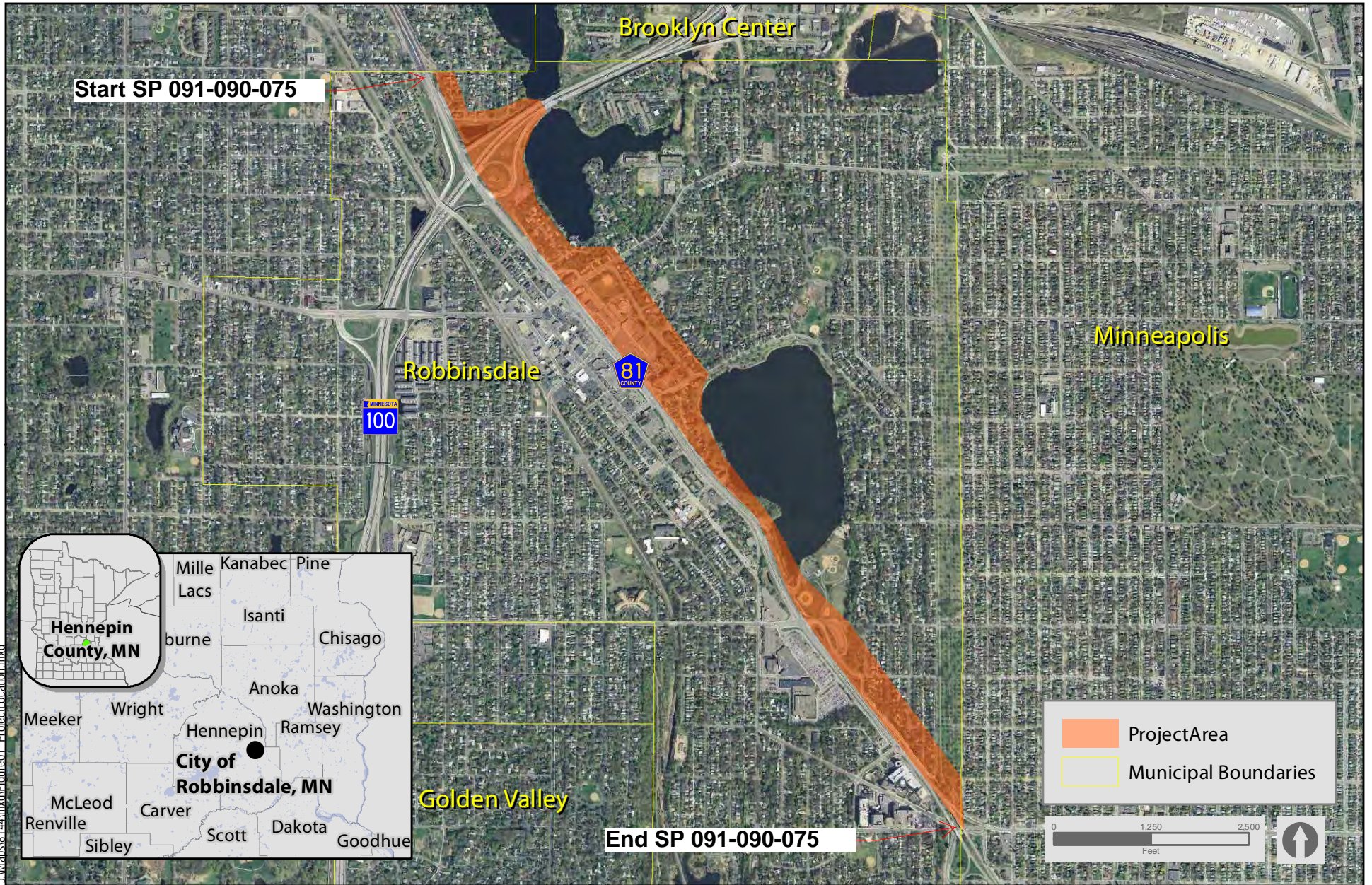

**Project Location**

Crystal Lake Regional Trail  
 SP 091-090-075  
 City of Robbinsdale, Minnesota

Figure 1