

SOUTHWEST

Green Line LRT Extension



# Visual Quality Guide (VQG)

Final for Approval June 30, 2015

**DRAFT**



# Table of Contents

## 1.0 Executive Summary

## 2.0 Introduction

## 3.0 Bridge Substructures

3.0.1 Hammer Head Pier LRT, FRT, TRL

3.0.2 Twin Hammer Head Pier LRT

3.0.3 Monolithic Pier

3.0.4 Pipe Pile Bent

3.0.5 Abutment Pilasters

## 3.1 Other Corridor Treatments to Bridges

3.1.1 Shady Oak LRT

3.1.2 I-494 LRT

3.1.3 Glenwood Ave. Vehicle and LRT Bridge

3.1.4 LRT Bridge 5<sup>th</sup> and 7<sup>th</sup>

3.1.5 Crash Protection Barriers

## 4.0 Tunnels

4.0.1 Pedestrian Entrance Portals

## 5.0 Retaining Walls

5.1.1 Corridor Wide Wall Textures

5.1.2 Wall Coping

5.1.3 Minor Off-system Site Retaining Walls

## 6.0 Railing/Fencing

6.1 Safety Railing

## 7.0 Color Palette

## 8.0 Summary of Aesthetics Application - Roll Plots

# 1.0 Executive Summary

## **Purpose**

The SWLRT Visual Quality Guide (VQG) is a working document intended primarily for the use of the SWLRT structures design team as a resource to enable the unified integration and application of the visual quality elements into major structures such as bridge substructures, bridge abutments, site retaining wall elements. As a working document, it is expected that details will be refined as constructability, cost considerations and technical design advances among the multitude of structures on the project. The VQG does not address station architecture as this covered by other documentation.

The SWLRT Structures Aesthetics Goals for the base design include:

- Develop a corridor wide aesthetic for these elements which is flexible to accommodate some level of local community expression and/or local context.
- Establish a corridor wide approach to structures which is unique to the SWRLT corridor.
- Establish universal parameters for structures aesthetic elements which will facilitate the advancement of the structures design while final aesthetic treatments are still being finalized.
- Unify the design of the structures to the greatest extent possible such that they share a common kit of parts.

The visual quality guidance for SWLRT structures as documented in this guide describes a corridor wide approach to the aesthetic treatment for major structures, bridges and retaining walls within the SWLRT corridor. Exceptions to the application of the corridor wide aesthetic have been made for structures at the following locations: I-494 &, TH 100, TH 212 (which follow MnDOT corridor aesthetic) Kenilworth corridor, (aesthetics are undetermined at this time as elements in this portion of the LRT corridor remains under study) and; Glenwood Ave. and the 5<sup>th</sup> and 7<sup>th</sup> LRT facilities which will follow aesthetic cues from surrounding infrastructure. The VQG constitutes the base design improvements which are to be included in the project. It does not include items which may be voluntarily added by a Local Community Requested Investment (LRCI) which are being managed separately.

## **Elements to receive aesthetic treatment**

The following illustration identifies the basic elements of the LRT corridor to receive the aesthetic treatment.

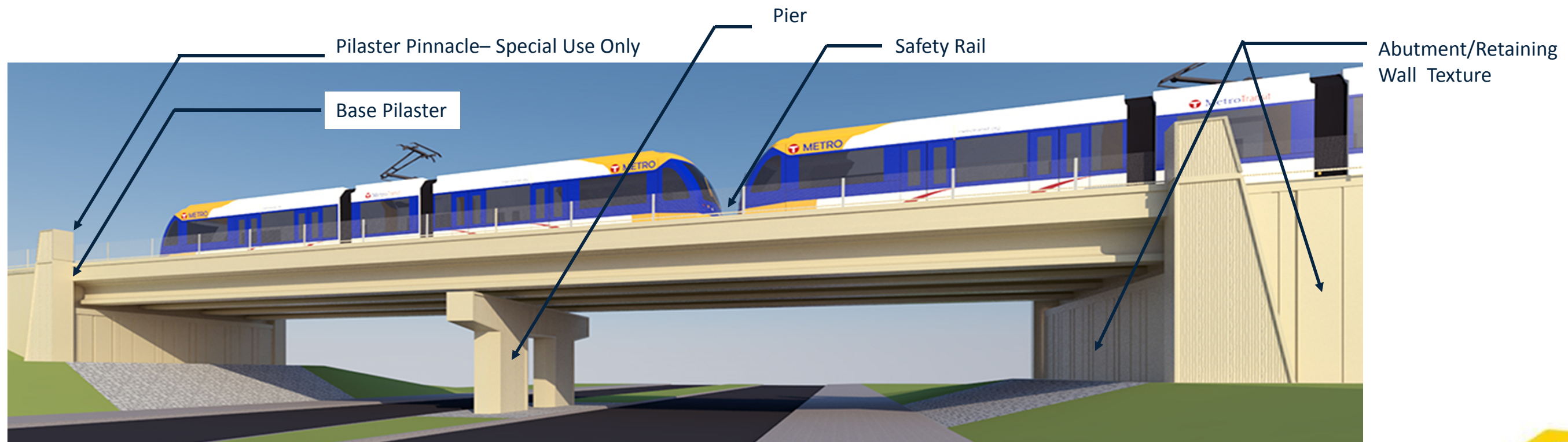



# 1.0 Executive Summary

## *Bridges*

The aesthetic approach for the SWLRT bridge facilities has been focused on two elements, the pier and the abutment area. The principal aesthetic components consist of a uniform pier form and abutment pilaster, with the following two styles.

Style 1. (Frame) consists of a monolithic pier and abutment pilaster of simple angular forms with crisp framing which accentuates the perimeter of the column and pilaster. The frame encloses a textured interior panel. This form is highly structured and deemed to be more appropriate for the dense urban locations along the corridor.

The Pilaster has the standard base and where warranted, the addition of the optional pinnacle is used to further mark prominent locations.



*Perspective View of LRT Bridge with Style 1 (Frame) with base Pilaster*

*Style 1 (Frame) Pilaster with optional Pinnacle*



# 1.0 Executive Summary

## ***Bridges - continued***

Style 2. (Edge) consists of a monolithic pier and pilaster form of simple angular forms in which the underside of pier cap and the outer edges of the column are recessed and textured. The outer edge of the accompanying pilaster is similarly treated. The form is less structured and deemed to be more appropriate for more open, natural and less developed areas of the corridor.

The Pilaster has the standard base and where warranted, the addition of the optional pinnacle is used to further mark prominent locations.

Style 2 (Edge) illustrated below

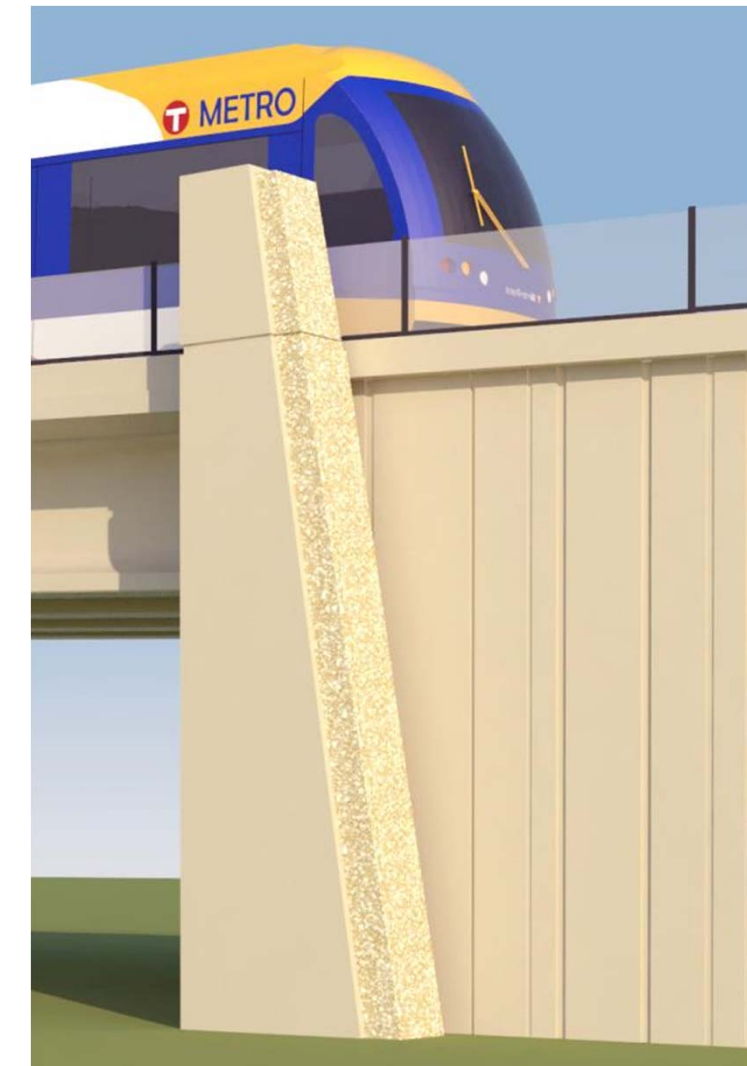

*Perspective View of LRT Bridge with Style 2 (Edge) with base Pilaster*

*Style 2 (Edge) Pilaster with optional Pinnacle*

# 1.0 Executive Summary

## Crash Protection

The structures within a rail corridor are required to have adequate separation and or crash protection. This requirement applies to both existing bridges in which the LRT track pass beneath as well as new LRT structures adjacent to heavy rail activity. The protection of existing structures is being accomplished through retro fitting of concrete crash walls surrounding the existing structures.

For new LRT structures, protection from vehicles and heavy rail is being accomplished primarily by sizing the piers such that no accessory crash protection walls are required. When this approach is not possible, crash walls will be constructed surrounding the bridge piers as described below.

The heights of required crash protection walls will be determined using appropriate technical design requirements for each location. After the required wall height and thickness is determined the following aesthetic treatment will be applied to all new crash walls unless otherwise stipulated. The aesthetic design includes a series of horizontal reveals in the face of the crash wall. Standard special surface finish will also be applied to all exposed wall surfaces.

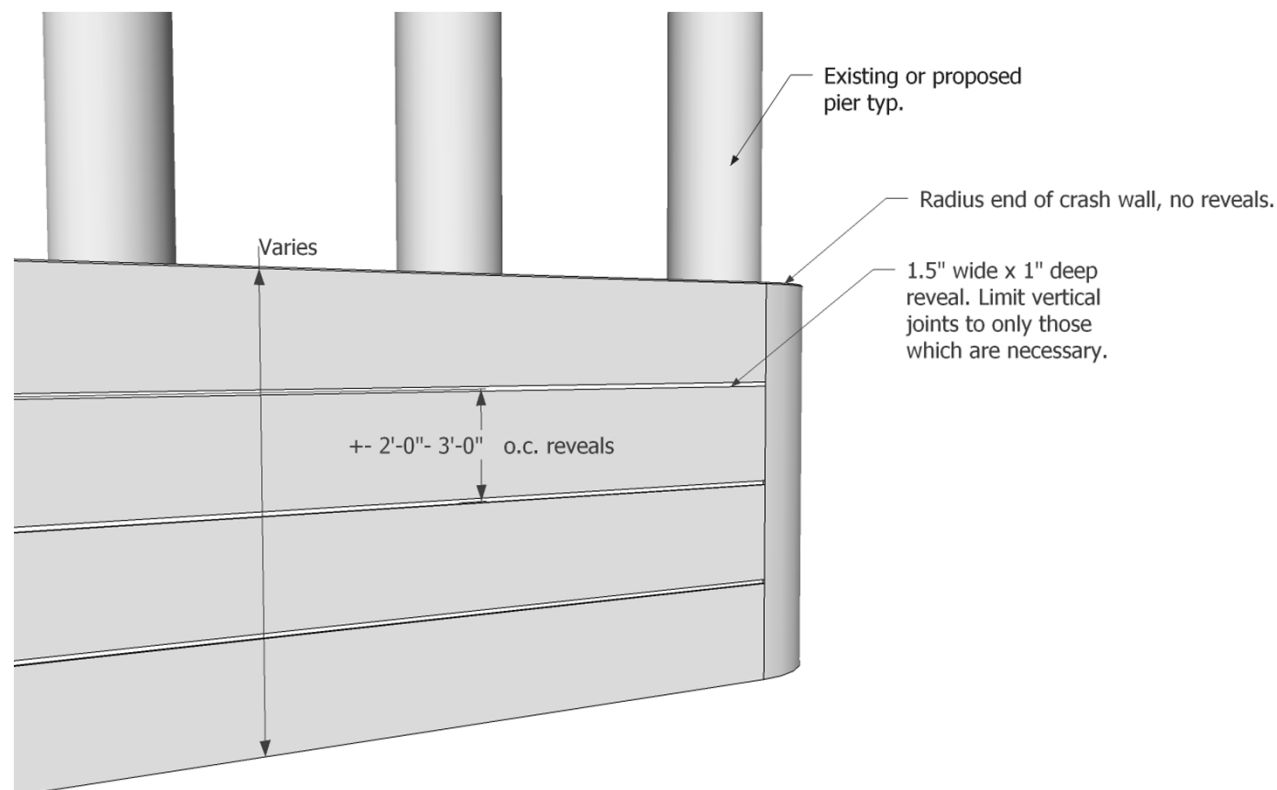

*Perspective view of crash wall aesthetic treatment*

# 1.0 Executive Summary

## *Pedestrian Underpasses*

It is anticipated that at some locations along the corridor pedestrian underpasses will be constructed to allow for safe movement of pedestrians under roadways and or the LRT track. The pedestrian underpass opening concept consists of a simple rectangular frame with sufficient space in the lintel in which to cast the name of the adjacent LRT station. The frame also allows the end of the precast tunnel segments to be masked resulting in a more pleasing appearance. The frame is anticipated to be constructed of cast-in-place concrete with smooth surface and coated with special surface finish to match the flanking retaining walls.

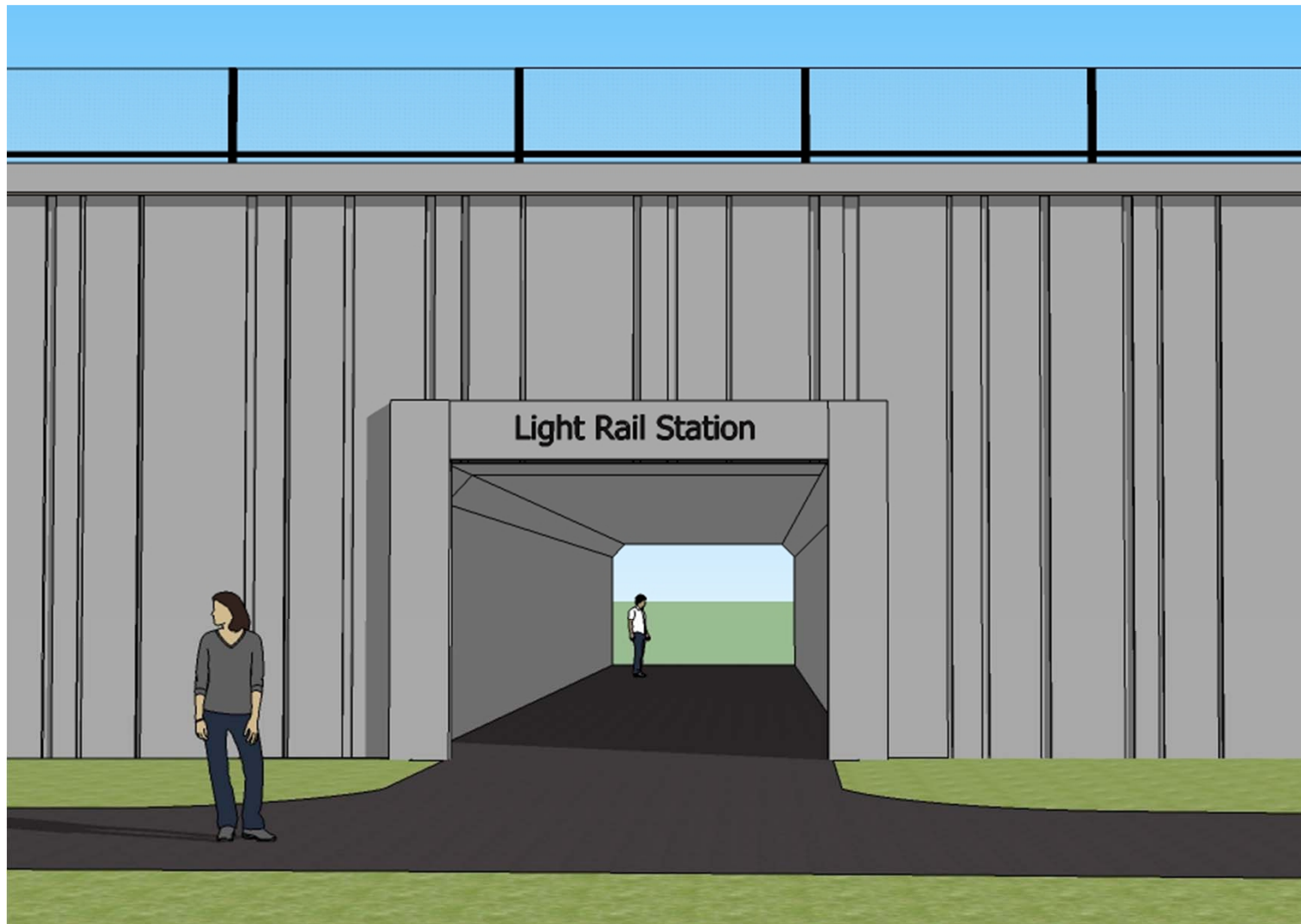

*Perspective View of Pedestrian Underpass*



# 1.0 Executive Summary

## Retaining wall, abutment and wing wall textures

The development of the SWLRT Corridor within the built environment requires the use of significant amounts of retaining walls including those associated with bridge abutments, LRT stations and general site retaining walls. The majority of walls on the project are visible from the adjacent properties and as such demand special surface treatment. This will be achieved through the use of textured form work which will transfer the patterns to the concrete when the elements are constructed.

The approach to the aesthetic treatment for walls has been organized by wall location each being given a designation as either primary or feature walls.

## Primary Walls

Primary walls include bridge abutments, wing walls, and general site retaining walls. Textures 1-3 below have been identified for use on these walls which comprise the majority of the project walls. Preliminary assignment of wall texture to primary walls has been completed and will be tested further as a part of the final design process.

## Feature Walls

At LRT stations, pedestrian underpasses, and adjacent trails three alternative texture patterns have been selected for use. Selective use of these detailed patterns provide a higher level of visual interest and due to their unique character create the potential to provide way finding and identification for LRT station facilities. Preliminary assignment of wall texture to feature walls has been completed and will be tested further as a part of the final design process.

## Feature Walls

The following illustrate the wall texture patterns 1-3 for primary walls and texture patterns 4-6 for feature walls.

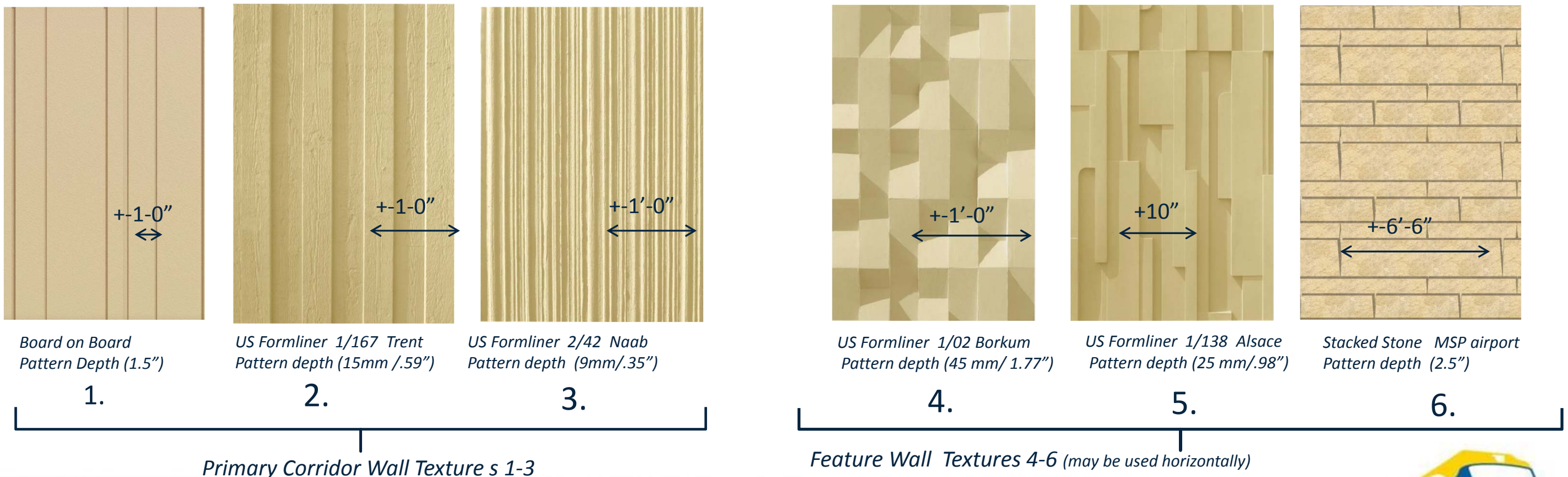

# 1.0 Executive Summary

## Safety Rail

All LRT structures and walls will be required to have safety railing at all locations which present a potential fall hazard. The height of the safety rail will be determined by functional location (bridge or wall) upon which it is placed. Safety rail will be constructed of similar materials on all SWLRT facilities and will be colored black.

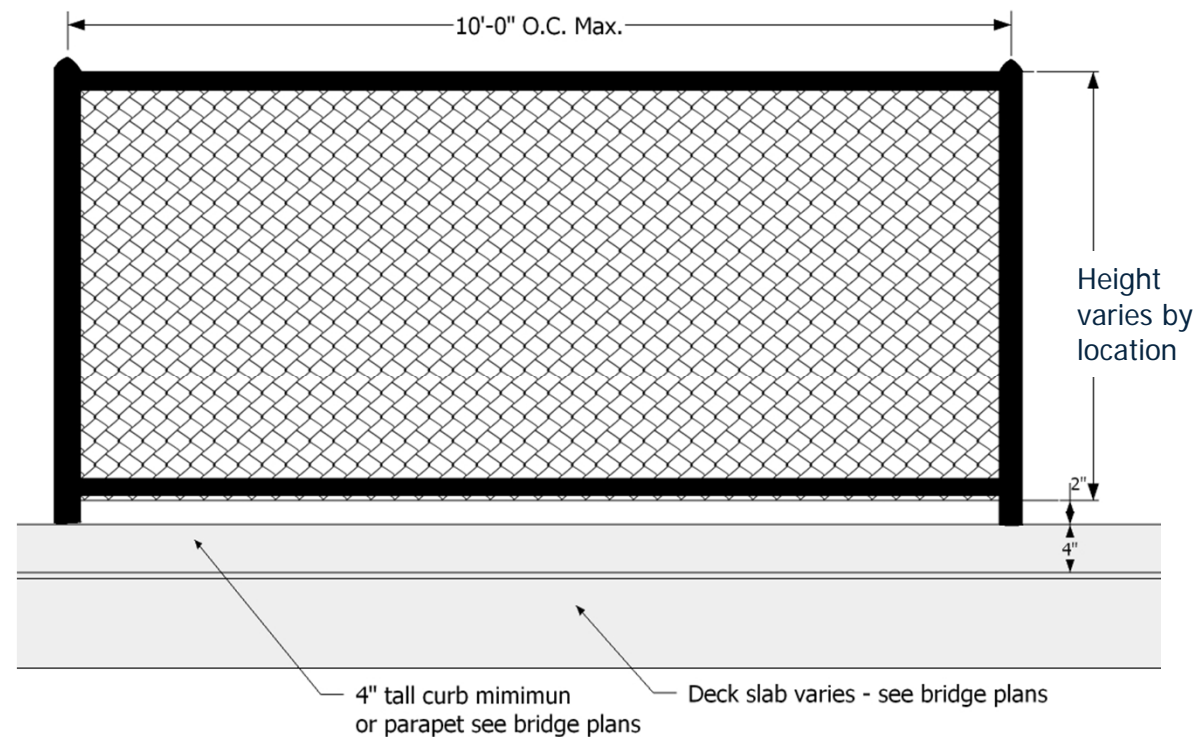

*Elevation view of Safety Railing*

## Color Palette

The use of color on the SWLRT structures is intended to be limited to a single color applied uniformly to all exterior LRT, freight and trail structures, walls, and bridges. The application of the color will be per MnDOT standard specifications for the element to receive the color surface finished. Safety railings and fencing will be colored black, the means of which will be determined during final design. Exceptions to this approach will include any structures which are located within MnDOT established aesthetic corridors in which case the color palette of the controlling corridor will be followed. Likewise new SWLRT structures adjacent to the Glenwood Ave. bridge and the 5<sup>th</sup> and 7<sup>th</sup> Ave. bridge which connects to the LRT structure at the "Interchange " will be coated with a color to match the adjacent infrastructure.

In specific locations, portions of bridges or walls may be given an accent color which has been requested as part of a Locally Requested Capital Investment ( LRCI). These alternative color selections will be directed via the LRCI process and will not be a part of this document.

The final corridor color has not been selected as of this date.



# 1.0 Executive Summary

## Summary of Aesthetics Application - Roll Plots

The following is an example image from the roll plots document (an appendix to the VQG) which summarizes the assigned aesthetic wall and bridge aesthetic treatments for all the major structures of the corridor. The roll plots identify the application of the Base Design and as such is a starting point for the Advanced Design Consultants. It is anticipated that as the final designs advance, cost containment and input from local communities, there may be changes to the assigned treatments as summarized on the roll plots. Guidance for these changes will be communicated as output from the Advance Design Meeting(ADM) or specific LRCI design development.

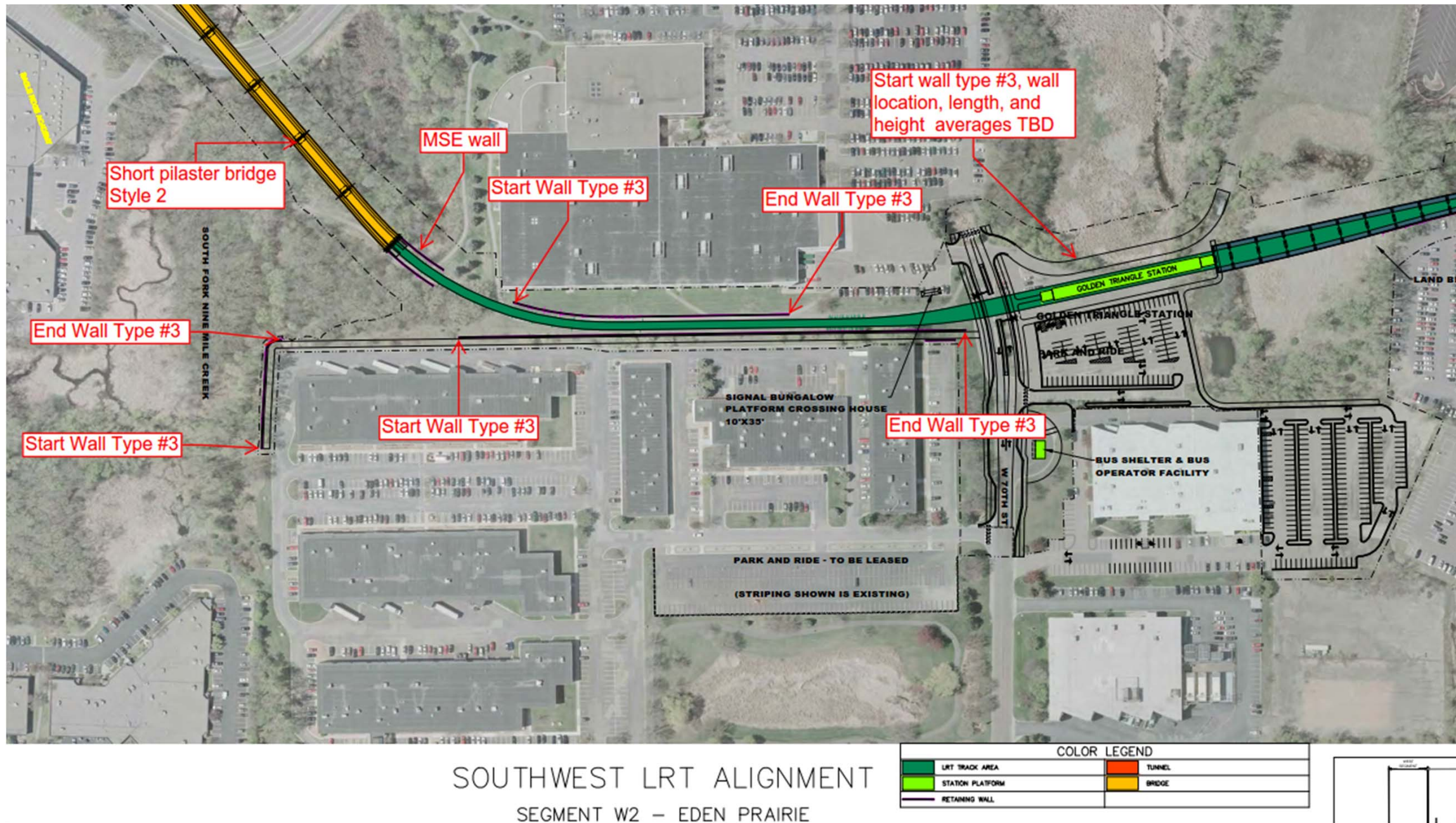



# 2.0 Introduction

## Process Overview

This comprehensive visual quality guide has been developed to provide aesthetic direction for the major structures of the project. The scope of the design guide is focused primarily on the bridge substructures (piers, abutments, wing walls), general site retaining wall textures, safety fencing/railing and; color palette for the above elements. The aesthetic character of LRT stations, and operations and maintenance facilities is not a part of this document.

The selection of concepts documented in this guide is the culmination of an iterative process with Southwest LRT Project Office (SPO) design staff, lead structures engineers and architecture representatives from the Southwest LRT (SWLRT) design consultancy. The process included several broader workshops with the bridge design and retaining wall design team. In these settings, numerous options and concepts were presented and illustrated in 2-D and 3-D for SPO preference comment and input and selection. The selected concepts have been further refined and illustrated to present to project partners at the Technical Project Advisory meetings and for internal use.

As this process has unfolded the advanced pace of bridge structures design has allowed the opportunity to test fit the chosen design concepts on several bridges. This testing has helped to refine the parameters of the design concepts which are now documented in this guideline. This test fitting has also allowed the design concepts to be incorporated in to 60% plans on a number of LRT, freight and trail bridges along the segment of the corridor principally west of the Wooddale Station.

## Base Design

The design concepts and direction contained in this document have been vetted by SPO staff and deemed to constitute the “Base Aesthetic Design “ being affordable within the base design and construction budgets. Specific requests by local communities for finishes other than those of the base design are not contained herein. It is anticipated that separate design guidance for the affected SWLRT elements will be prepared and distributed to the affected design team members for incorporation into the final design of the selected elements. This will likely occur after the requested changes have been vetted by the SWLRT design team and agreements are in place, with local communities to compensate the project for any additional cost incurred as a result of the special request. The development of the Locally Requested Capital Investment (LRCI) will similarly be developed and directed outside of this document. The LRCI improvements will be integrated within the final design documents and will supersede the design guidance contained herein for that element.

The SWLRT Structures Aesthetics Goals for the base design include:

- Develop a corridor wide aesthetic for these elements which is flexible to accommodate some level of local community expression and/or local context.
- Establish a corridor wide approach to structures which is unique to the SWLRT corridor.
- Establish universal parameters for structures aesthetic elements which will facilitate the advancement of the structures design while final aesthetic treatments are still being finalized.
- Unify the design of the structures to the greatest extent possible such that they share a common kit of parts.

The content of this design guide is subject to minor refinement as a part of the final design process should conditions arise. These conditions may include a need to increase safety, reduce long term maintenance issues and reduce capital cost. All refinements must result in equal or greater aesthetic quality at no additional cost to the project.

# 3.0 Bridge Substructures

## General Bridge Structures

The majority of the bridge structures within the corridor are designed to utilize standard pre-cast concrete girders with conventional span configurations and cast-in-place concrete substructure elements. Straight bridges maintain a consistent girder alignment and spacing with uniform deck overhang. Curved bridges utilize chorded girder placement with variable deck width and overhang. Parapets and edge curbs are applied uniformly on bridges rendering a generally consistent elevation aside from the girder depth which varies depending upon span length. Railing heights and density of enclosure may vary depending upon the functional requirements of each bridge.

The base design for all exposed bridge elements includes the application of special surface finish per MnDOT standard specifications. See color palette for corridor wide color. In specific locations, the color palette of the MnDOT corridor will take precedence.

## Special Bridge Structures

A box girder design has been proposed for approach spans on several trail bridges (TRL) crossing the corridor with the main spans completed using pre-engineered steel truss spans. The Light Rail (LRT) Excelsior Bridge is also proposed to be constructed using a variable depth box girder design. A concrete box girder design is also proposed for a portion of the 5<sup>th</sup> and 7<sup>th</sup> street LRT bridge.

Freight Rail (FRT) bridges are generally composed of Steel thru-girder or steel girder with concrete deck. Railing height and density vary depending upon location.

## Summary

In general the bridge parapets and edge curbs on all the concrete deck bridges are slender with little surface area for visual expression. Primary elements of these structures which allow the most opportunity for aesthetic treatment include:

- Piers and Pier Caps, Abutments, and Wing Walls,

Accessories to these bridges which might provide for additional aesthetic treatment include:

- Abutment Pilasters , Pilaster with Pinnacles and (Enhanced Railings -LRCl only)

# 3.0 Bridge Substructures

## Base Design

In response to the above, the effort to develop design guidance for bridges was focused on creating an aesthetic treatment to piers, abutments and wing walls within the context of the standard bridge design vocabulary, i.e. Precast concrete beams, cast in place walls and a generally uniform cross section to LRT, FRT and TRL bridge structures. In this regard, no effort was expended to explore exotic or signature structures along the corridor.

The objectives for the development of aesthetic treatment to the bridge elements were (in no particular order) as follows:

- Features and forms which will provide a sense of LRT identity without “heavy handed” LRT branding
- Timeless design
- Style neutral
- Cost effective
- Base design form(s) which can accept alternative treatment and minimal community requested enhancement

The following illustrations and design notes define the aesthetic concepts for the bridge sub structures. This design includes the use of a common pier shape (with minimal variations) and the use of a pilaster located at the corner of the bridge abutment. The pilaster form provides an anchorage of the bridge to the abutment and provides concealment of the beam seat as viewed perpendicular to the bridge. The illustration below identifies the major components which will facilitate the development of a corridor aesthetic on major structures.

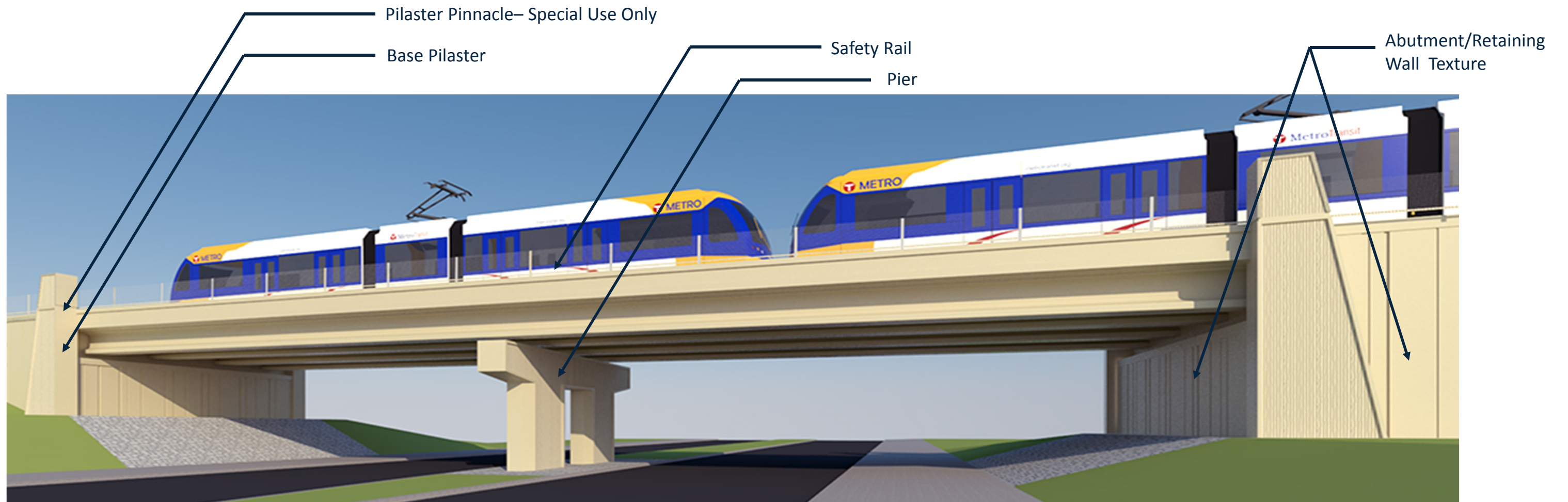

*Perspective View of LRT Bridge with basic design elements*



# 3.0.1 Hammer Head Pier Base Design Form - LRT

## General Hammer Head Pier Form

The base design form for the bridge piers consists of a column shaft which is approximately 10' wide and +/- 4'6" in width with large chamfers on the ends of the column shaft. The underside of the cap is faceted between the shaft and the end of the cap on Style 1 (Frame) and single sloped surface on Style 2 (Edge).

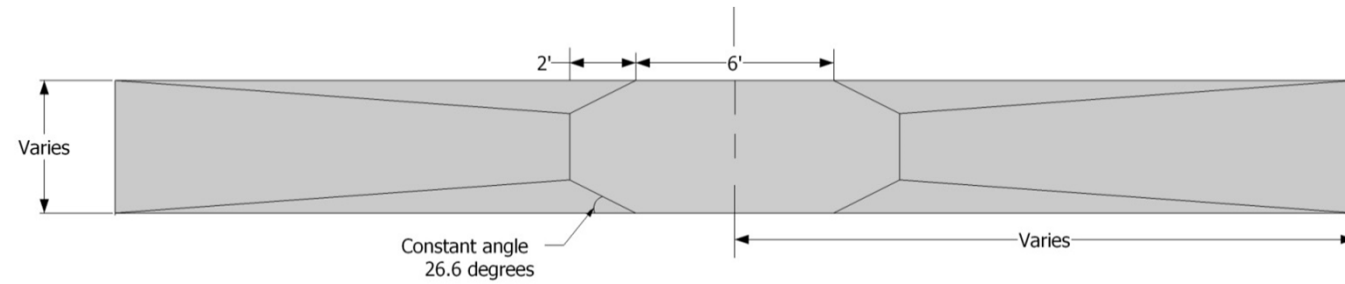

Pier- Plan View

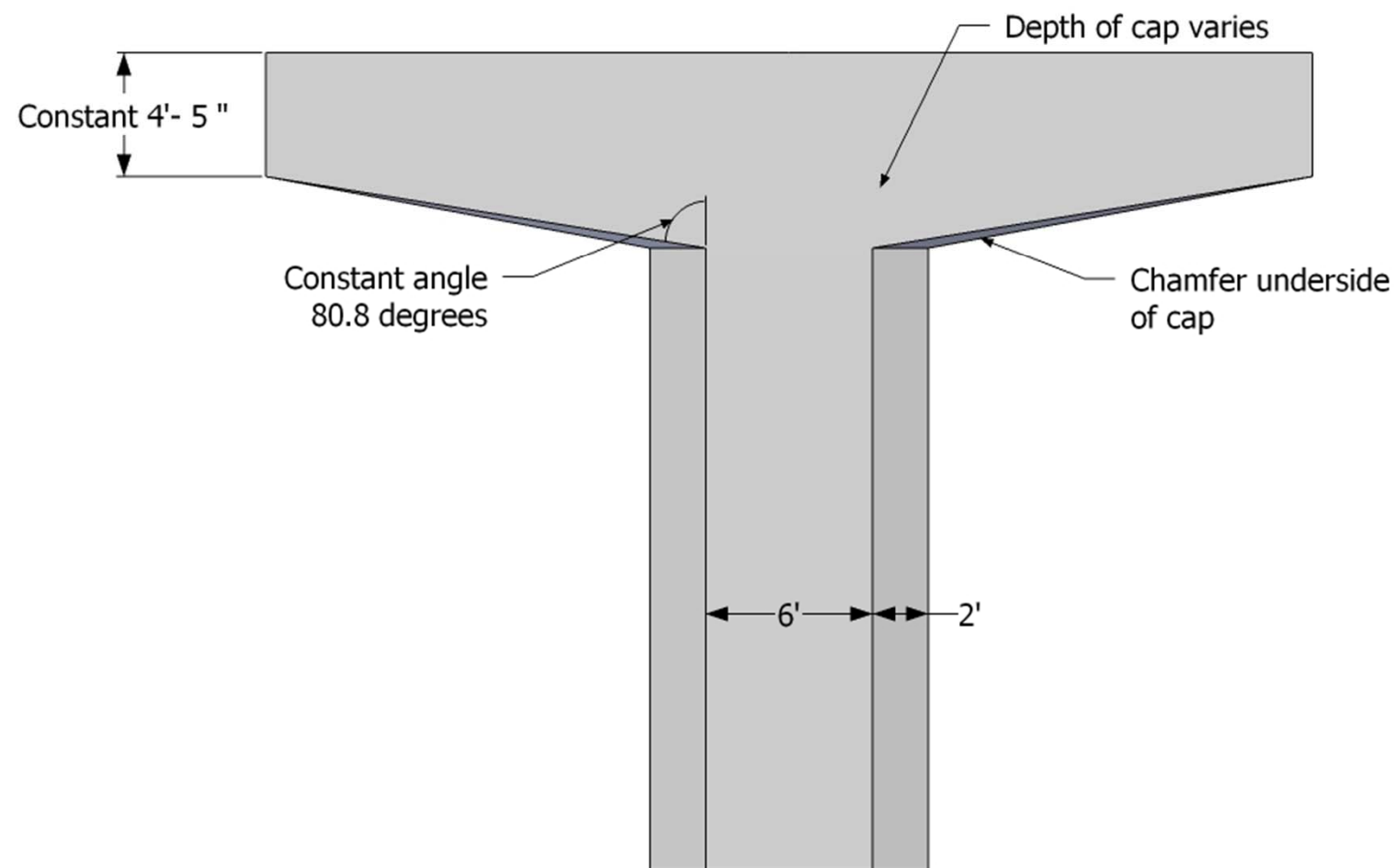

Pier- Elevation View

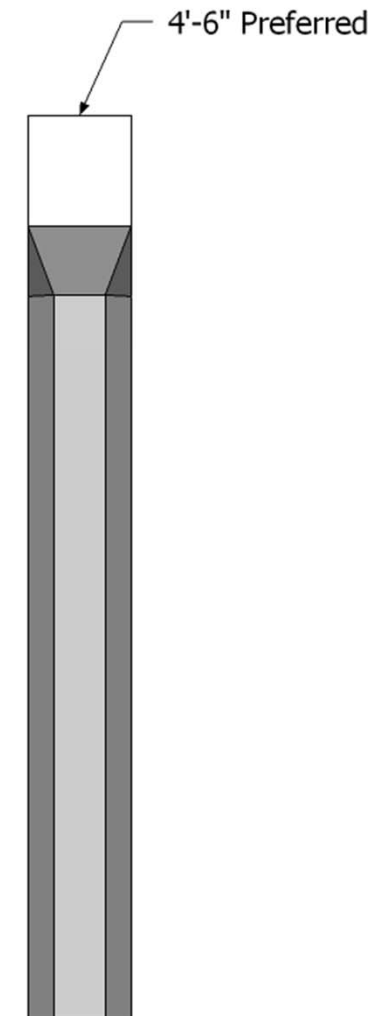

End view

## Design Notes

- Hammer Head form is continuous, face of cap and stem are in the same plane.
- Width of column stem may be adjusted as required to accommodate girder seat. 4'6" preferred as base design- strive for constant width
- Angle of chamfer between column face and edge to remain constant 26.6 degrees.
- Angle between stem and cap arms to remain constant. 80.8 degrees
- Depth of cap may vary as required - strive for constant depth
- All chamfers on column edges to be 1/2" maximum

# 3.0.1 Hammer Head Pier - Aesthetic Style 1 (Frame)

## Aesthetic Style 1 (Frame) Application

The base design form for the bridge pier is modified to create a smooth continuous frame surrounding the column stem and cap.

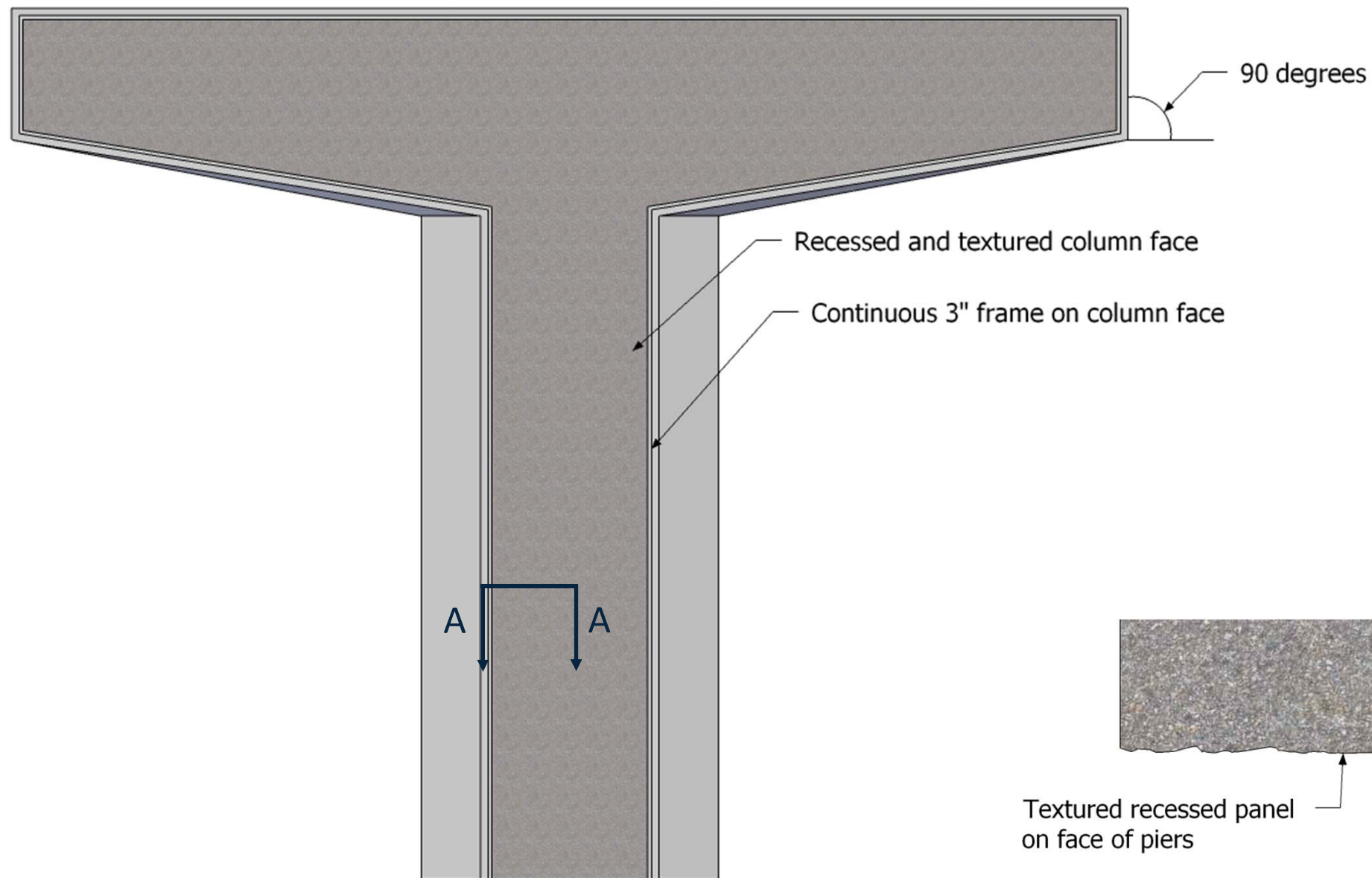

Elevation - Hammer Head Pier

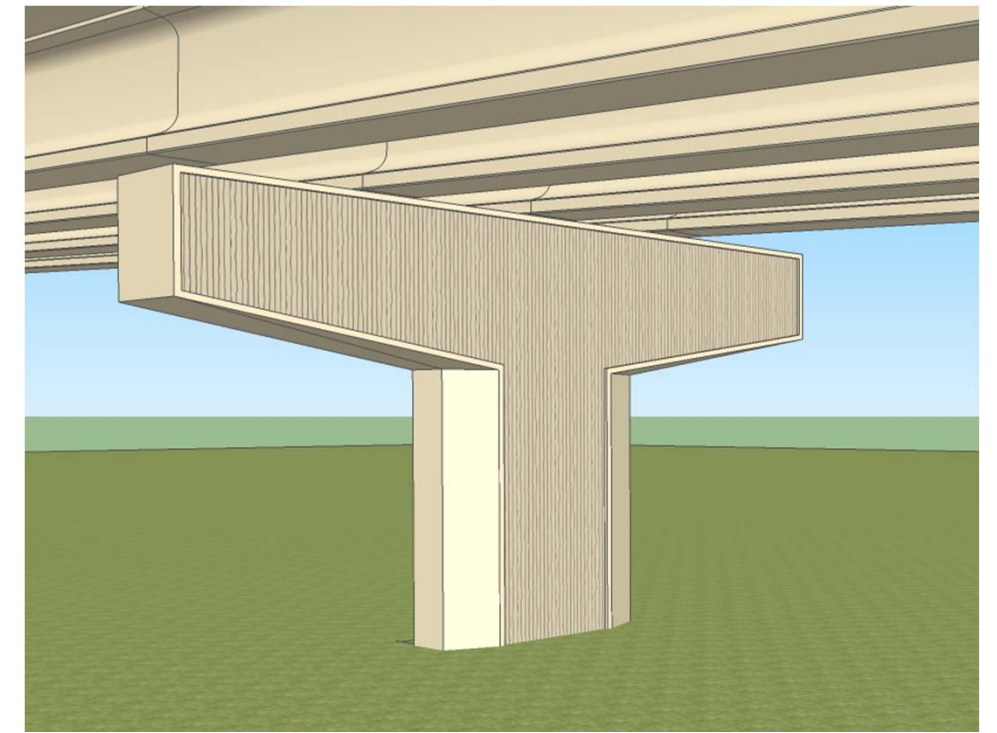

## Design Notes

Basic proportions and geometry of column layout are identical to base design.

Depth of pier may be adjusted as required to accommodate girder seat. 4'6" preferred as base design

Depth of cap may vary as required by design - strive for a constant depth.

All chamfers on pier edges to be 1/2" maximum

Faces of pier to have continuous frame and reveal - see detail

Texture on face of pier to be 1/2" maximum relief.

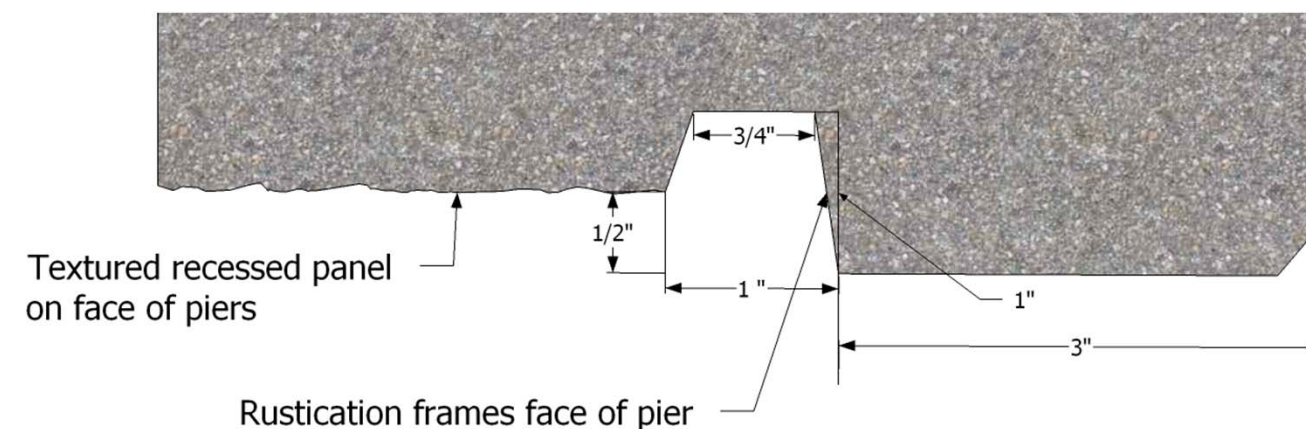

Partial Section A-A - Edge of Hammer Head Pier



# 3.0.1 Hammer Head Pier - Aesthetic Style 2 (Edge)

## Aesthetic Style 2 (Edge) Application

The base design form for the bridge pier is modified to create a smooth continuous surface of the column shaft and cap. The underside of the cap is reduced on all sides with the underside of the cap arms having a single sloped surface. The underside of the cap and the chamfered edges of the column receive a surface texture.

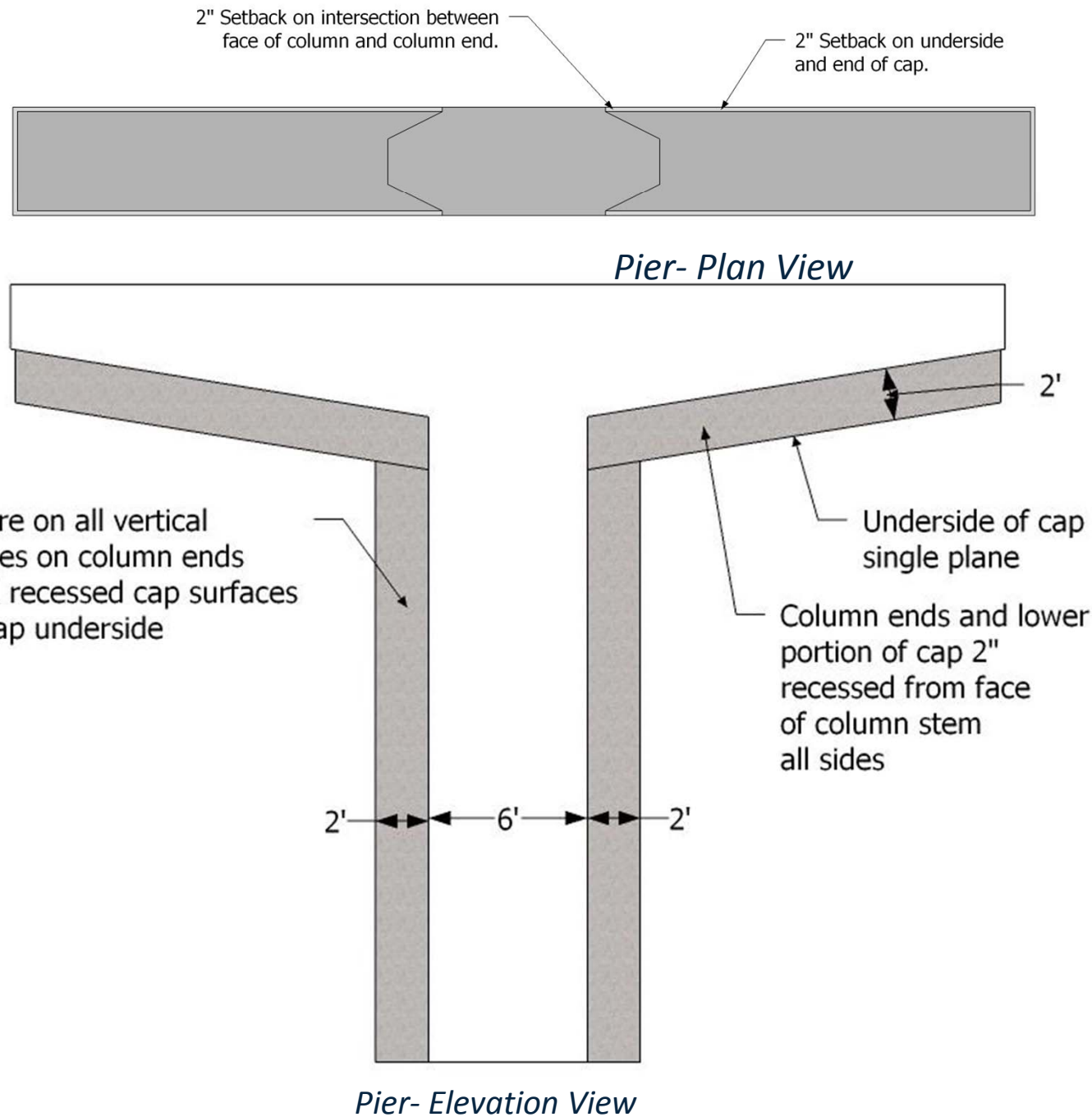
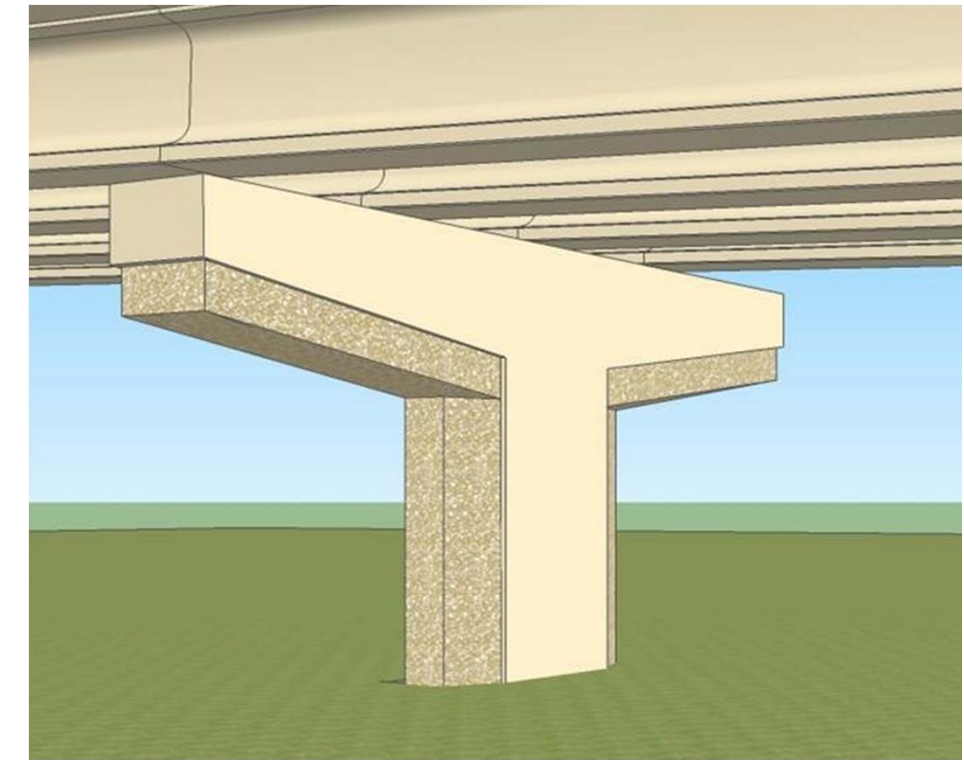

### Design Notes

- Proportions and angles of column layout are identical to base design.
- Depth of pier may be adjusted as required to accommodate girder seat. 4'6" preferred as base design
- Depth of cap may vary as required by design - strive for a constant depth.
- All chamfers on pier edges to be 1/2" maximum
- Texture to be 1/2" maximum relief.
- Apply similar details on Light Rail Transit (LRT), Freight Rail (FRT) and Trail (TRL) bridge substructures where they occur in a common location unless otherwise located in the prescriptive corridor, i.e. I-494, T.H. 212, T.H. 100



## 3.0.2 Twin Hammer Head Pier LRT

### Design Notes

- Proportions of column layout are altered from base design to increase cross sectional area eliminating the need for crash walls.
- Depth of pier may be adjusted as required to accommodate girder seat. 3'6" preferred as base design
- Depth of cap may vary as required by design – desired 3'-10" strive for a constant depth.
- All chamfers on pier edges to be ½" maximum
- Texture to be ½" maximum relief.
- Use similar approach on FRT and TRL bridge substructures where they occur in a common location unless otherwise located in the prescriptive corridor, i.e. I-494, T.H. 212 , T.H. 100

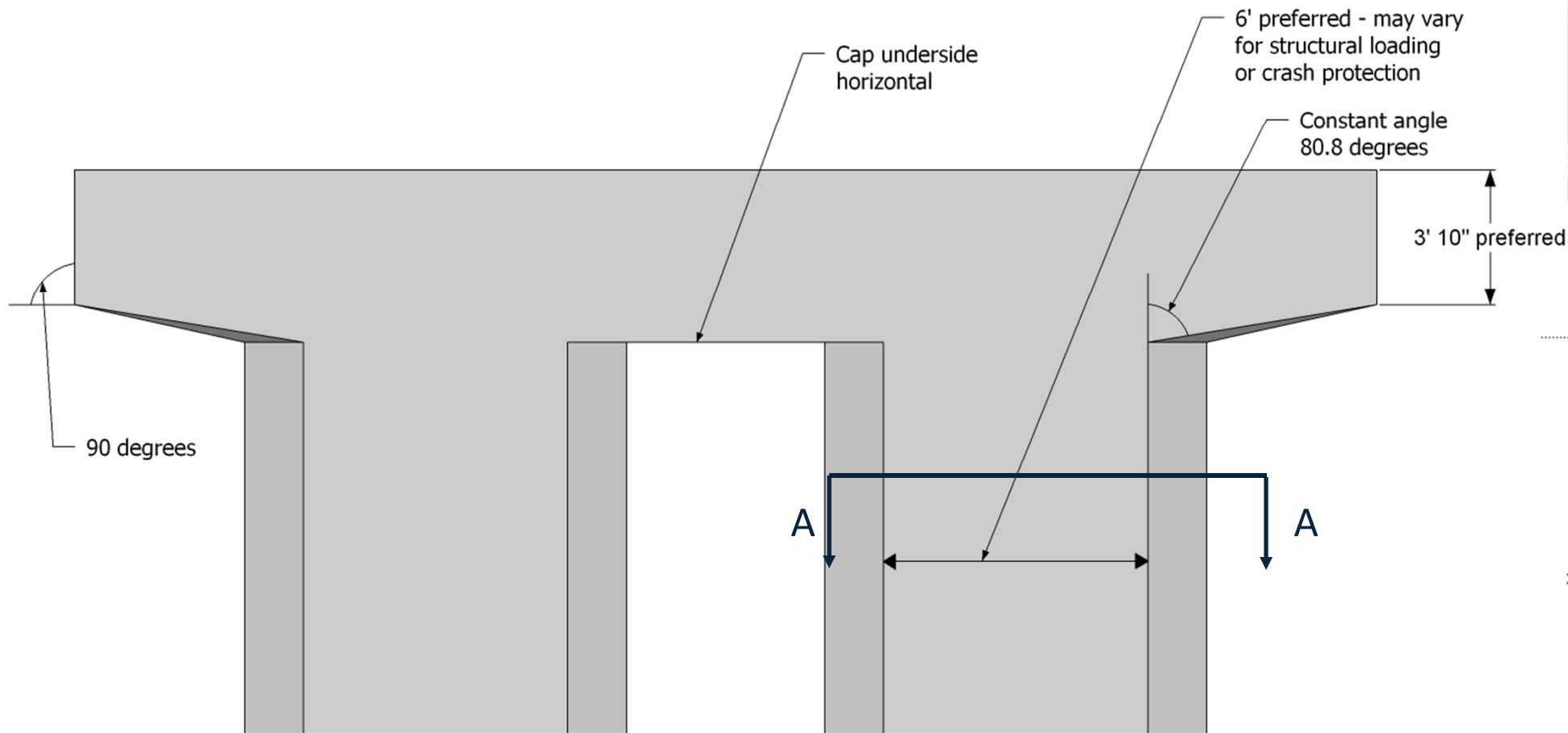

Elevation - Twin Hammer Head Pier

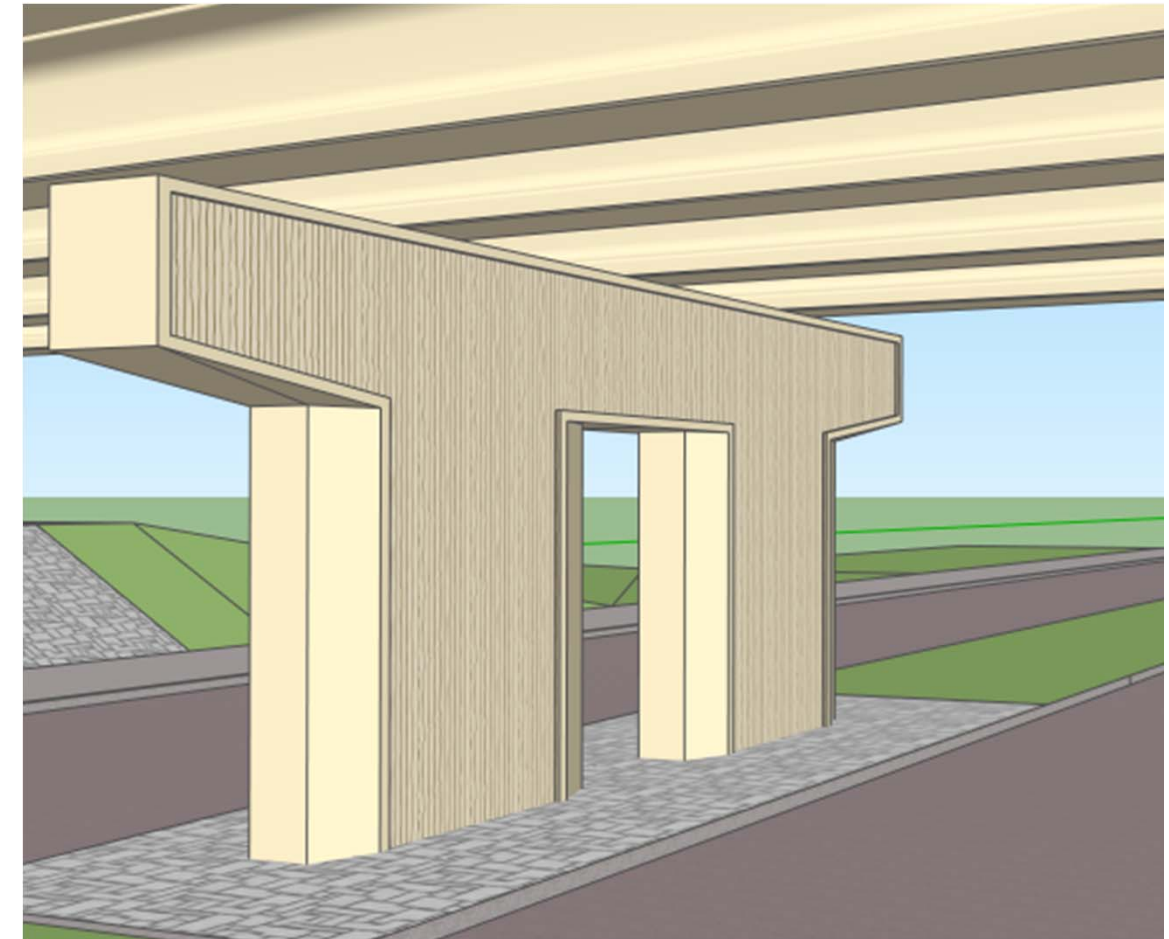

Perspective View Style 1 (Frame)

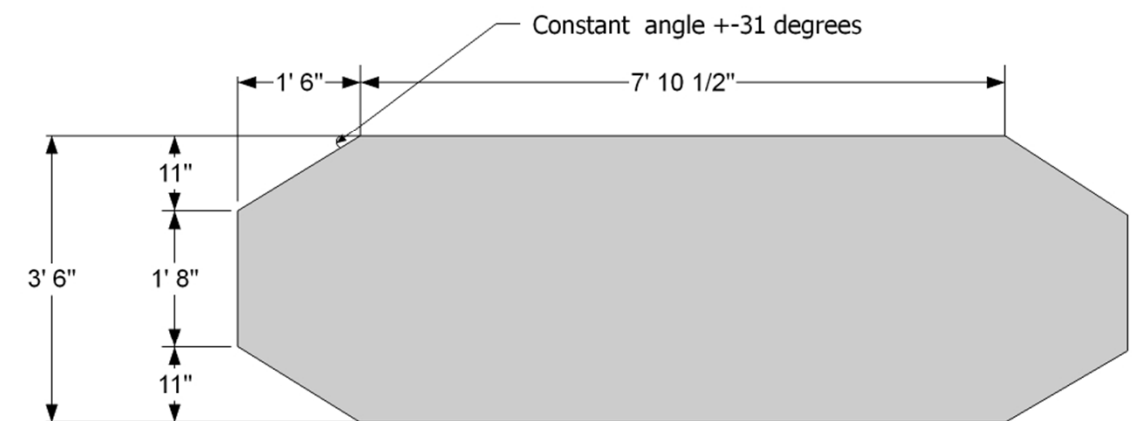

Section A-A – typical shaft

# 3.0.2 Style 1 (Frame) Illustration Twin Hammer Head LRT, FRT, TRL

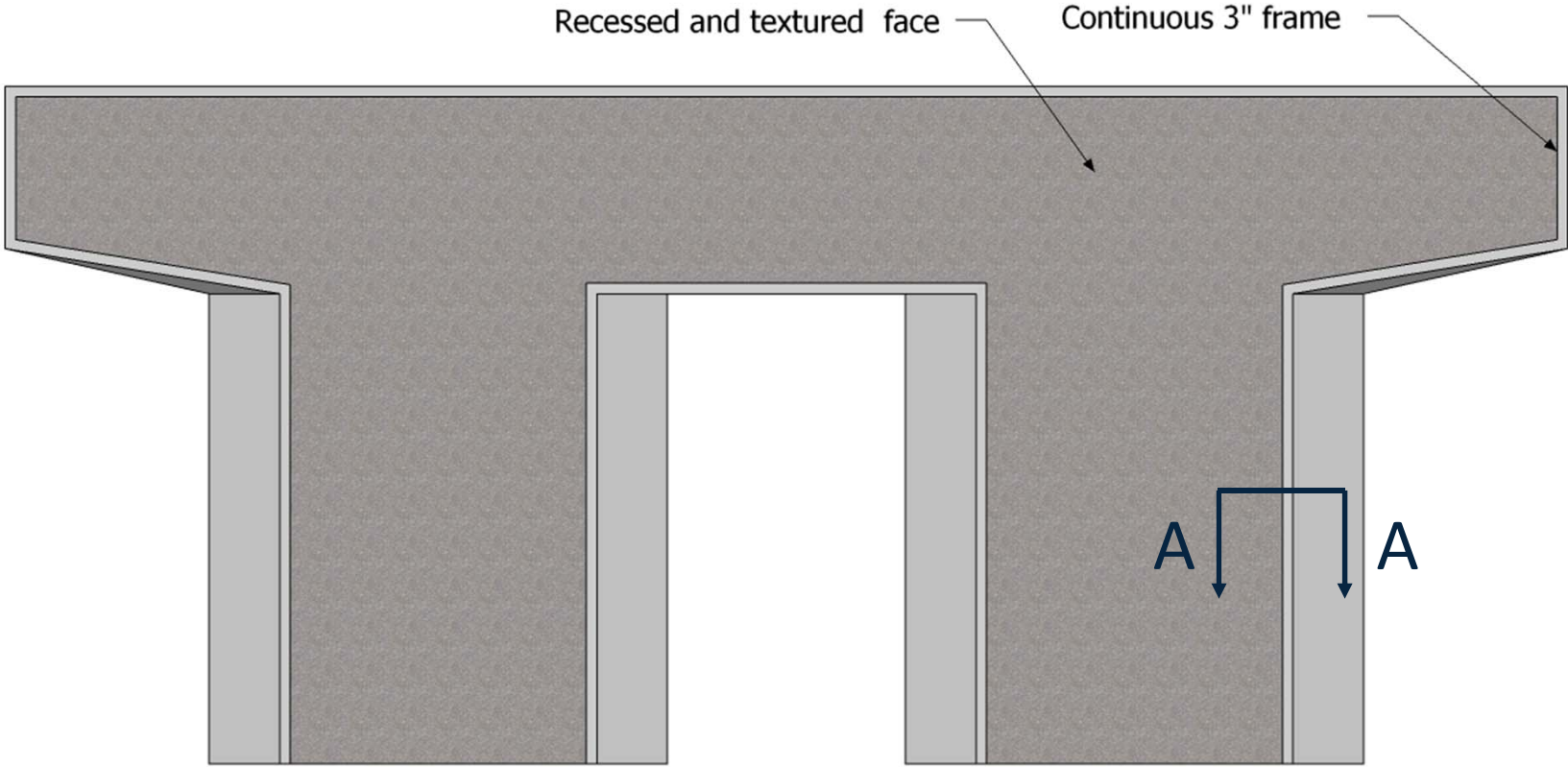

Elevation - LRT Twin Hammer head pier

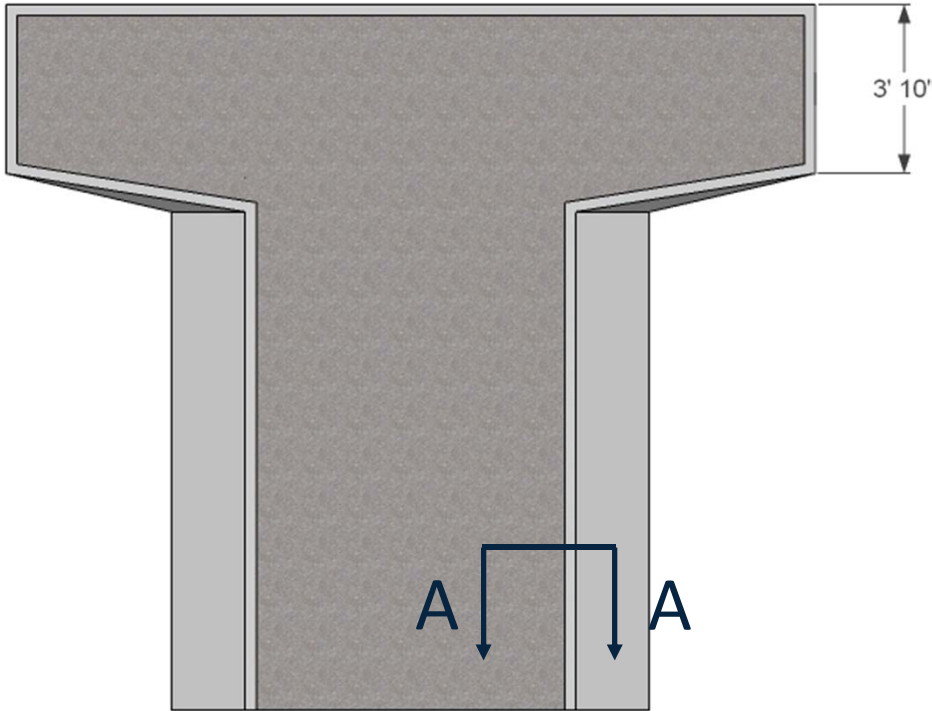

Elevation FRT Hammer head pier

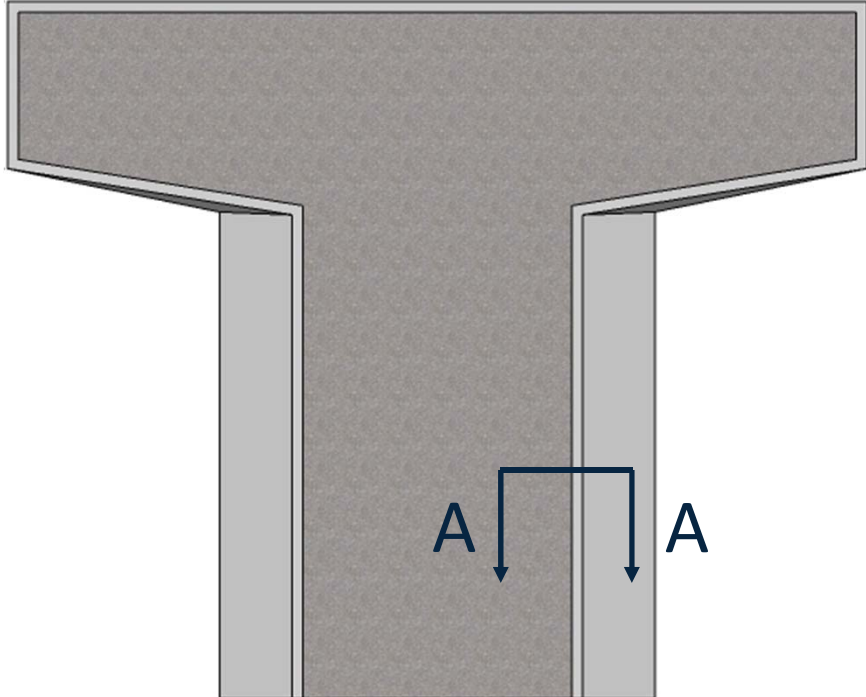

Elevation TRL Hammer head pier

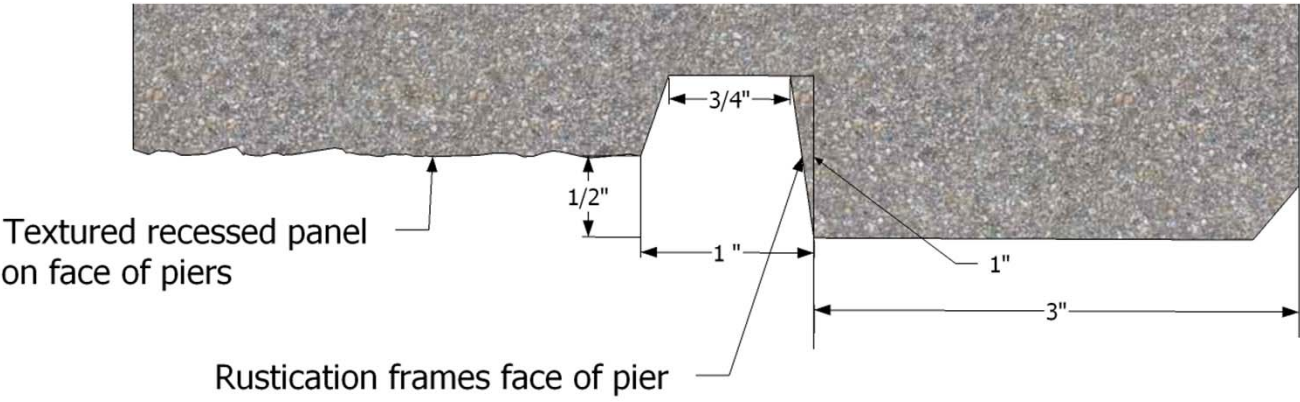

Partial Section A-A Edge of Pier



### 3.0.3 Monolithic Piers- Excelsior LRT Basic Pier Form

#### Design Notes

- Depth of pier may be adjusted as required to accommodate frame and aesthetic layer +- 8' preferred as base design
- All chamfers on pier edges to be 1/2" maximum
- Texture to be 1" maximum relief.

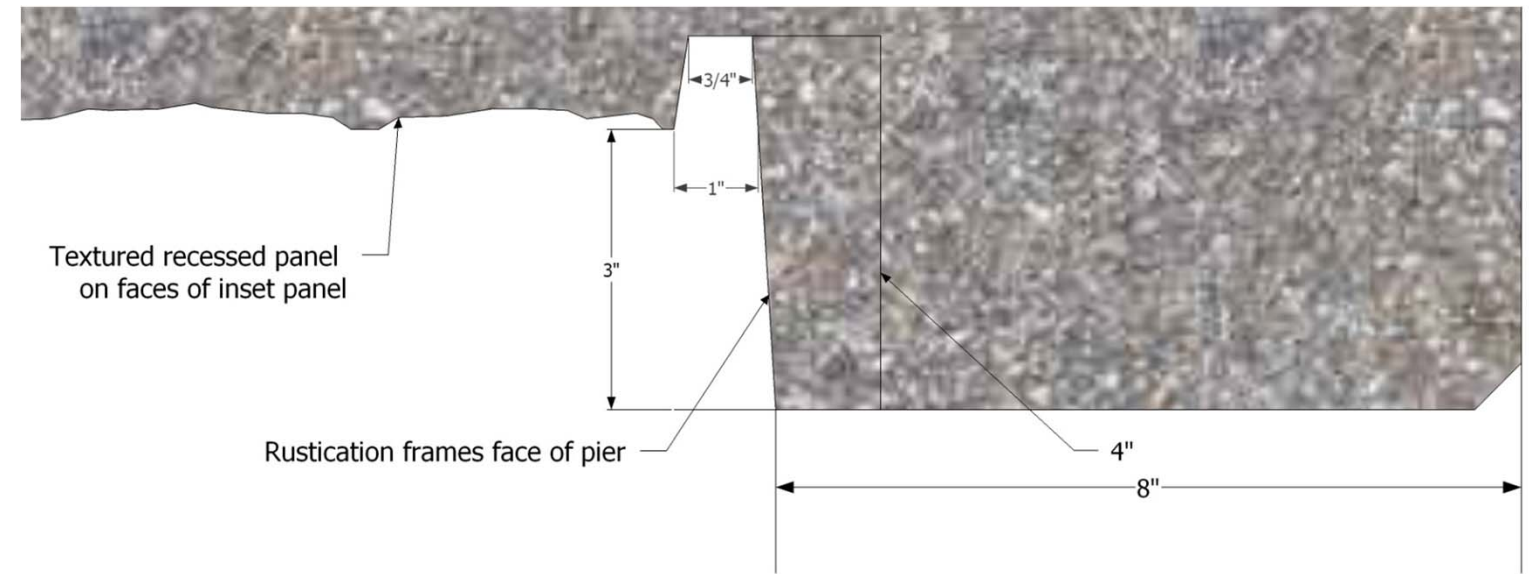

Section A-A Frame

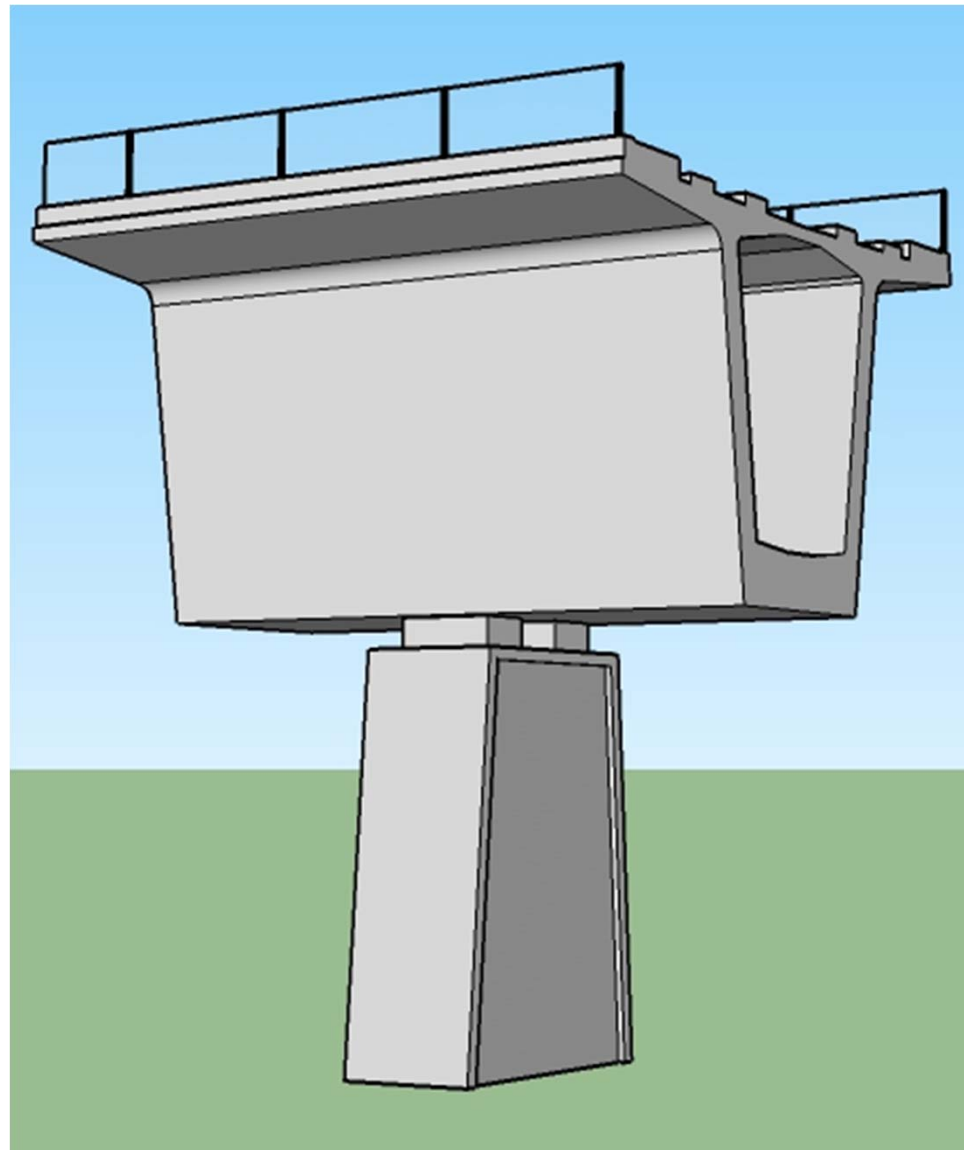

Perspective View— Typical Pier

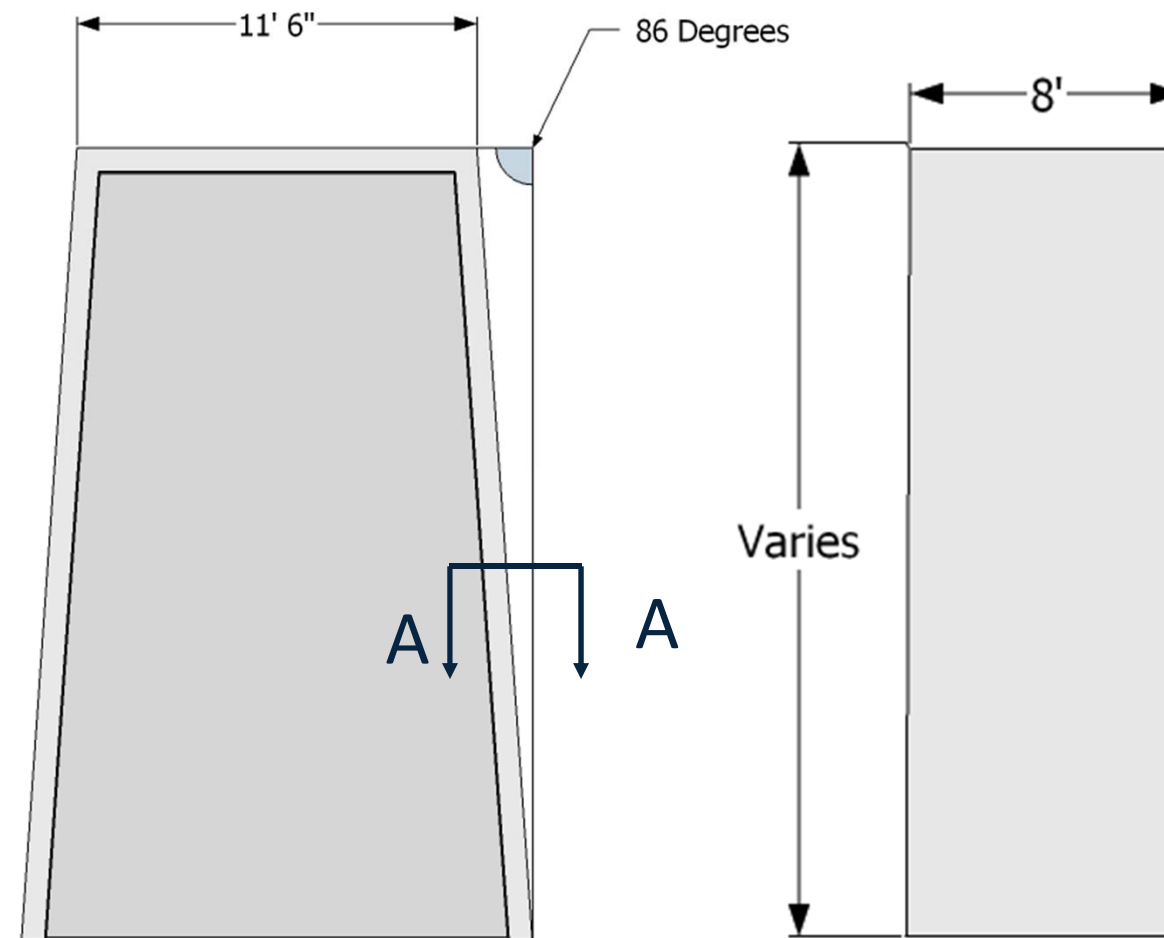

Elevation View – Typical Pier

End View – Typical Pier



### 3.0.4 Pipe Pile Bents - Minnetonka Hopkins, LRT (prototype for land bridges with exposed bents)

#### Design Notes

- Strive to maintain consistent pipe pile size and surface. Avoid spiral pipe if at all possible.
- Depth of cap may be adjusted to meet structural requirements
- Height of cap end desired 3'-0" - strive for a constant depth.
- Chamfer underside of cap  $\pm 6 \frac{3}{4}$ "
- For pipe pile piers where underside of cap is within two feet of existing grade no chamfer or tapered end is required.
- Paint exposed metal pipe pile to match concrete surface finish

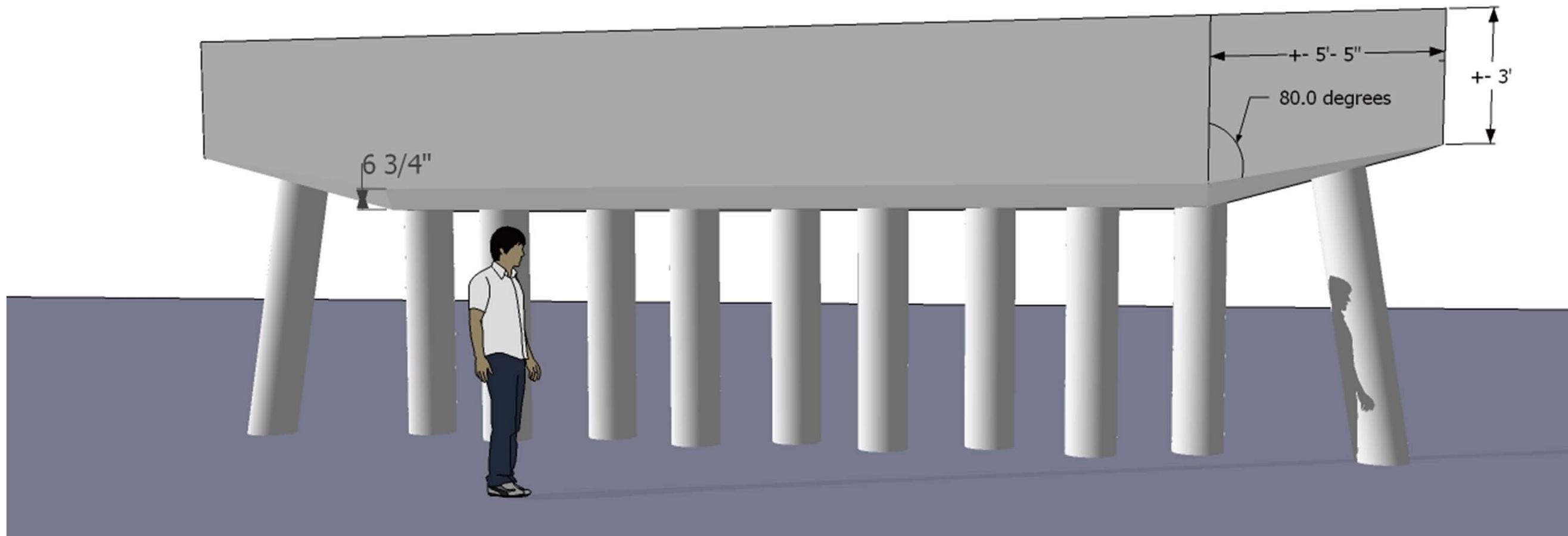

*Perspective of Pipe Pile Bent Cap*

### 3.0.5 Abutment Pilaster: Style 1(Frame)



*LRT bridge pier with base pilaster and pinnacle*



*LRT bridge - abutment view*



*LRT bridge pier with base pilaster only*



*LRT bridge - abutment view*



### 3.0.5 Abutment Pilaster : Style 2 (Edge)



*LRT bridge pier with base pilaster and pinnacle*



*LRT bridge - abutment view*



*LRT bridge pier with base pilaster only*



*LRT bridge - abutment view*



# 3.0.5 Abutment Pilaster – General Geometry and Dimensions

## Design Notes

- The use of pilasters is reserved for specific bridges in the corridor. See summary sheet at end of document for specific application of pilaster type on affected bridges

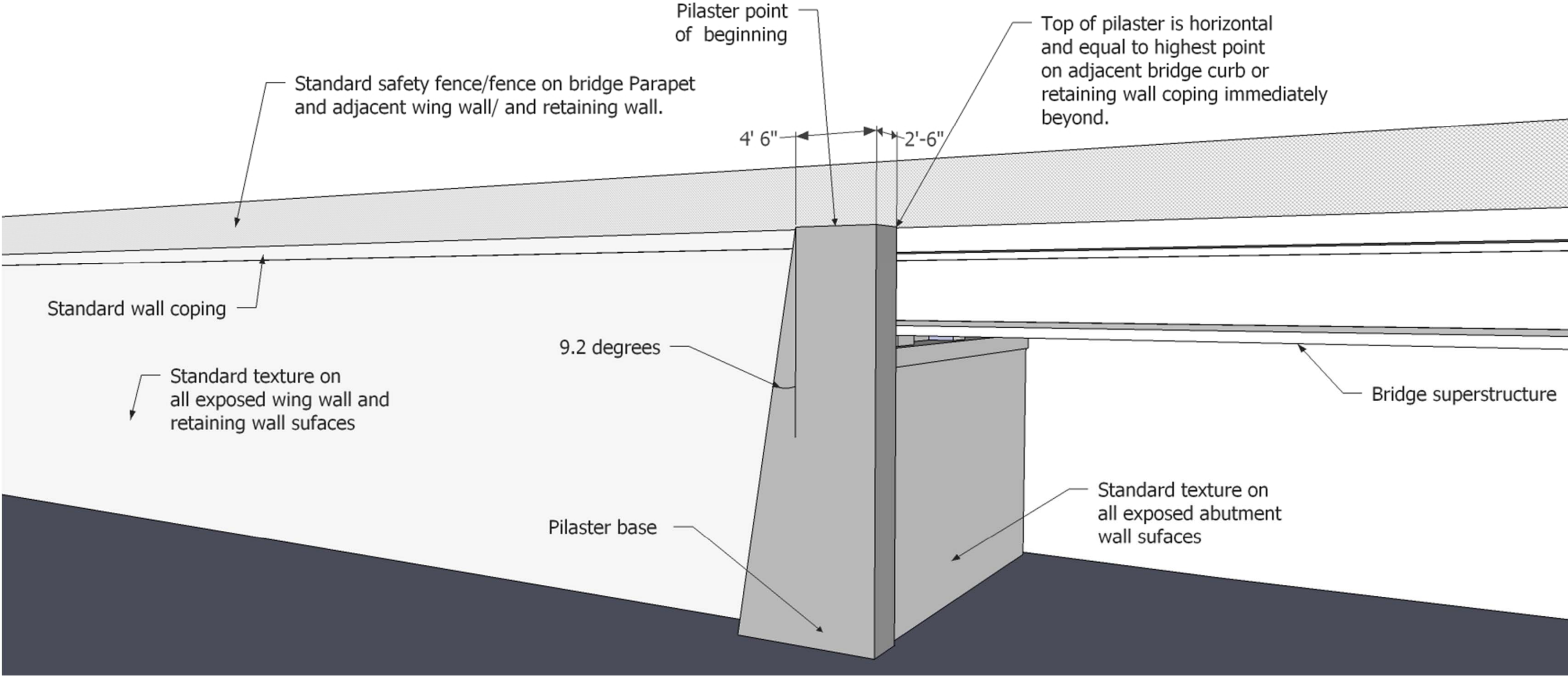

Partial Perspective View of Bridge with Pilaster

# 3.0.5 Abutment Pilaster – General Geometry and Dimensions

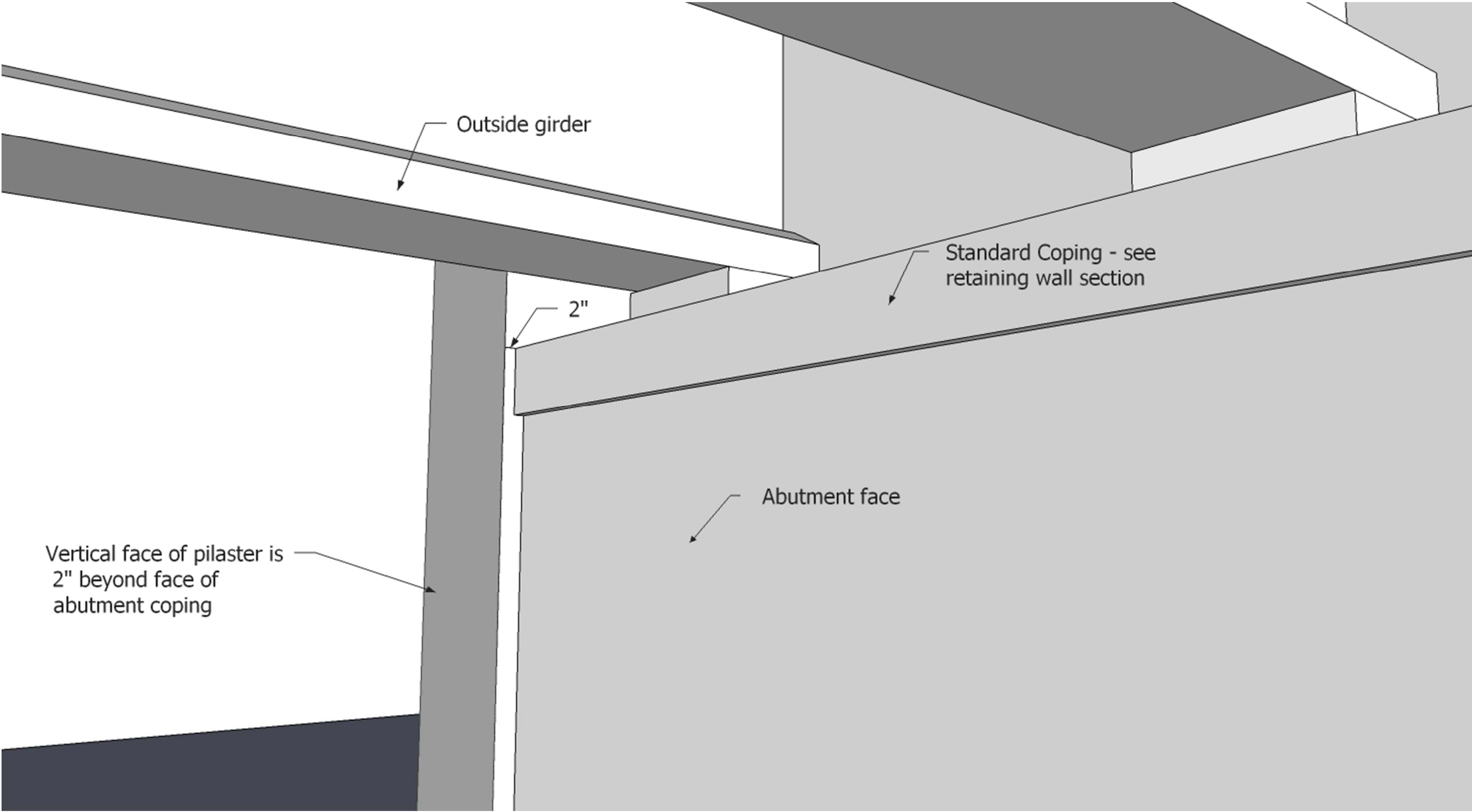

*View to Pilaster from Under Bridge Showing Relationship to Coping*



# 3.0.5 Abutment Pilaster: Style 1(Frame)

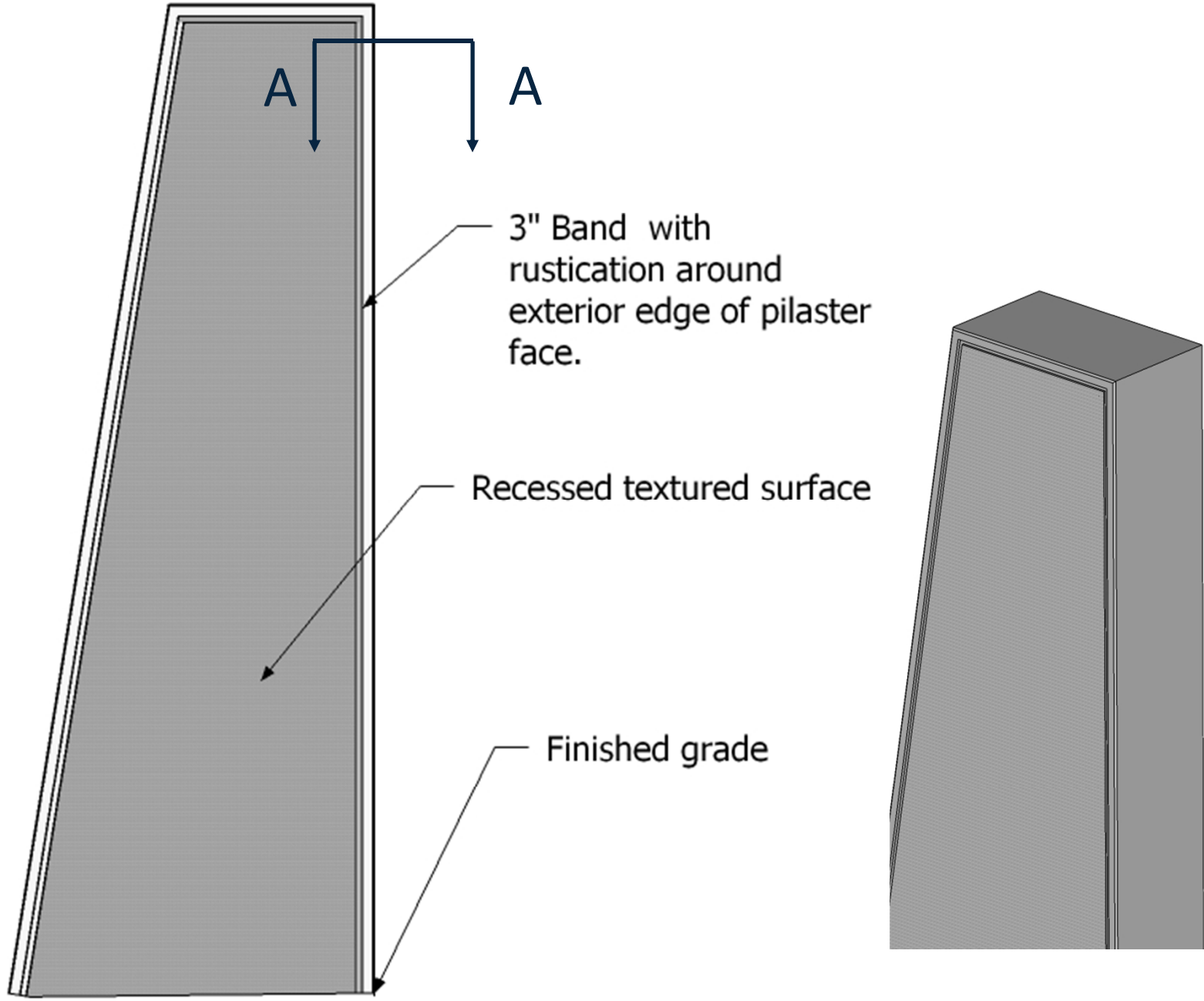

Elevation - Pilaster Face

Partial Perspective of Pilaster

### Design Notes

- Pilaster dimensions are common for all locations unless otherwise noted
- The base portion of the pilaster shall be constructed as a single piece as construction joints will not be allowed in either the horizontal or vertical plane of the pilaster.
- Depth of pilaster projection away from the adjacent wall may be reduced if roadway or track clearances dictate. Maintain a minimum of 1'-6"
- All chamfers on pilaster edges to be 1/2" maximum
- Texture to be 1" maximum relief from face of frame.
- Inside face of pilaster adjacent to beam seat does not receive frame or texture.
- Provide separation of pilaster as required from face of bridge deck, parapet and adjacent wing wall or retaining wall.

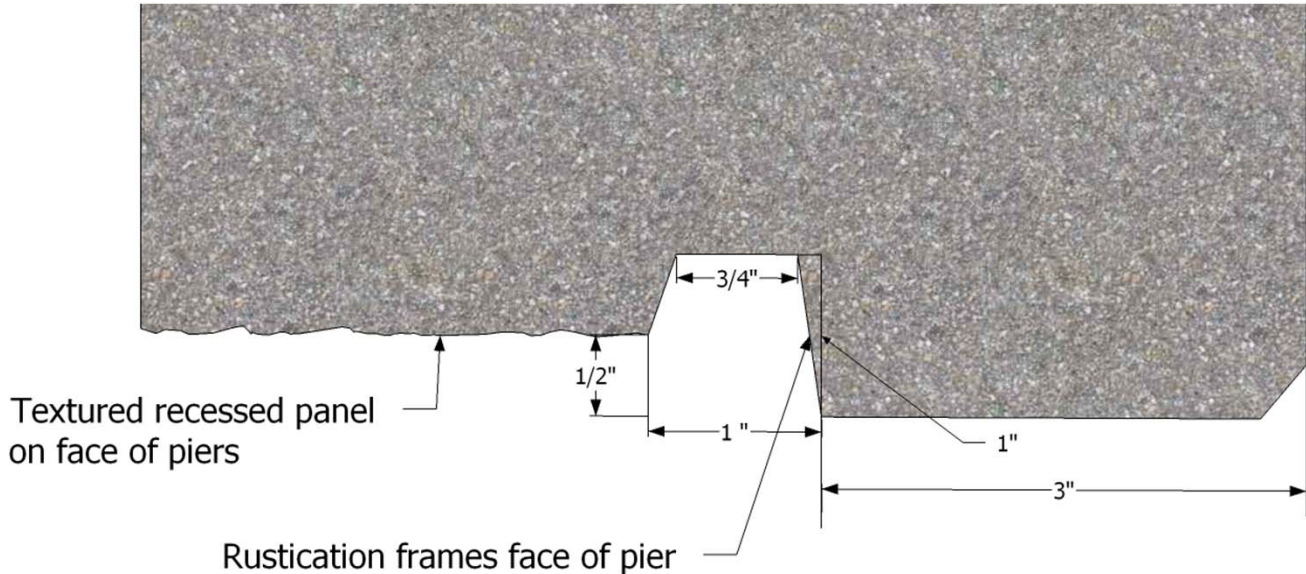

Partial Section A-A

# 3.0.5 Abutment Pilaster: Style 1 (Frame) – Pilaster Pinnacle

Design Notes

- Pilaster dimensions are common for all locations unless otherwise noted
- The base portion of the pilaster shall be constructed as a single piece as construction joints will not be allowed in either the horizontal or vertical plane.
- Depth of pilaster projection away from the adjacent wall may be reduced if roadway or track clearances dictate. Maintain a minimum of 1'-0"
- All chamfers on pilaster edges to be 1/2" maximum
- Texture to be 1" maximum relief from face of frame.
- Inside face of pilaster adjacent to beam seat does not receive frame or texture.
- Provide separation of pilaster as required from face of bridge deck, parapet and adjacent wing wall or retaining wall.

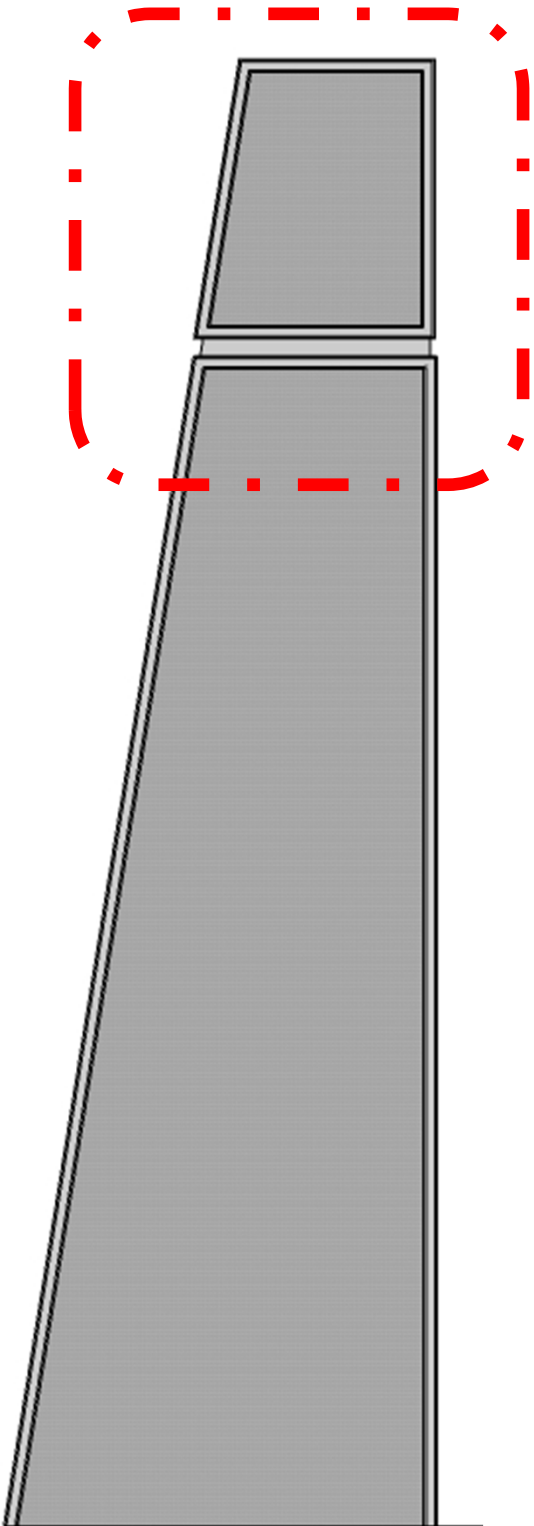

Optional pinnacle see enlargement

Both sides of pinnacle to have same frame, recess and surface finish.

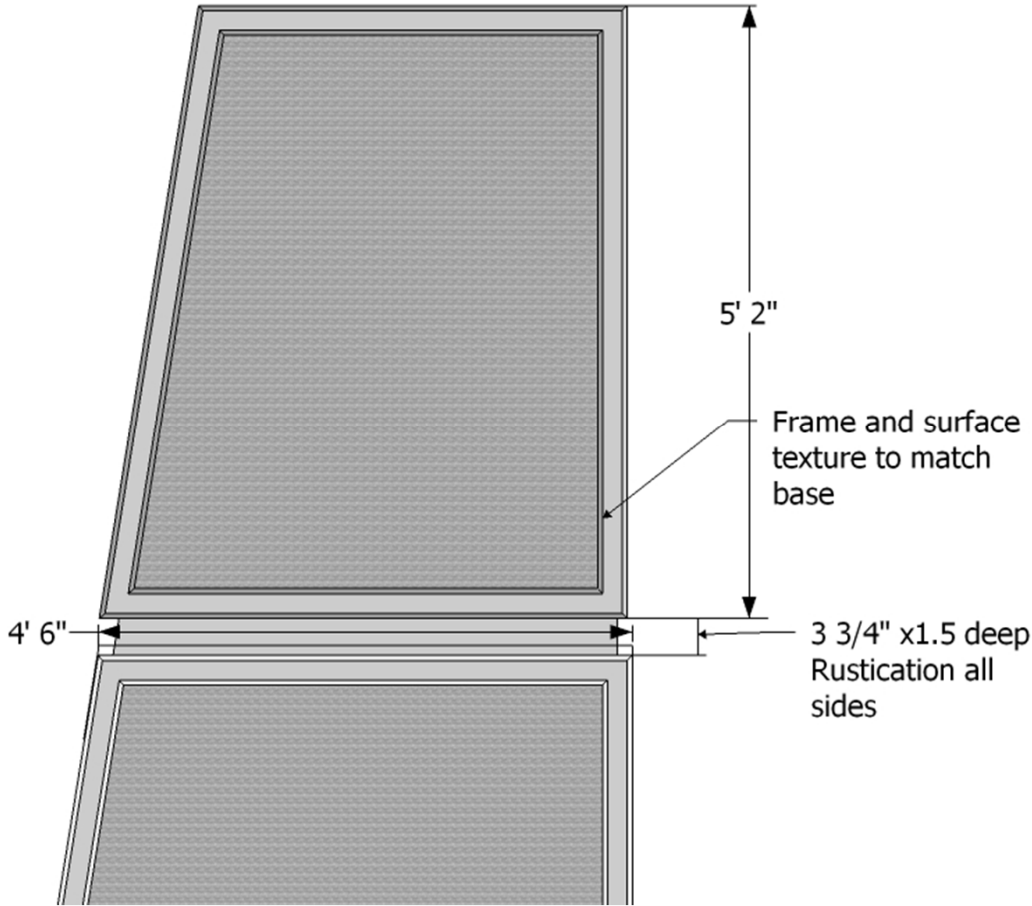
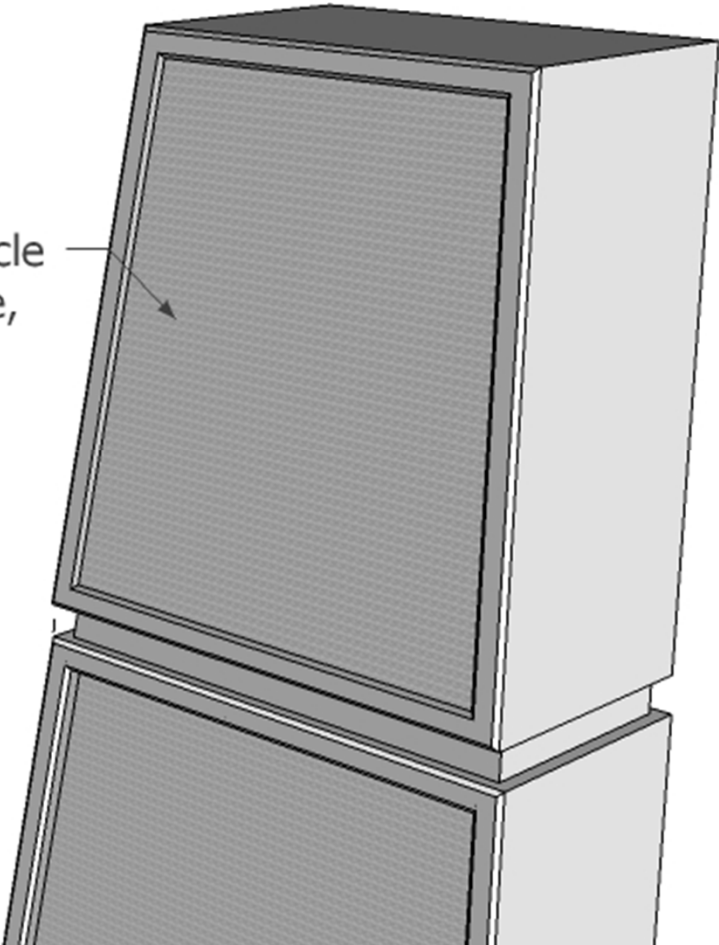

Elevation- pilaster optional pinnacle

Perspective of optional pinnacle

Elevation- optional pinnacle



# 3.0.5 Abutment Pilaster: Style 2 (Edge) – Pilaster Base

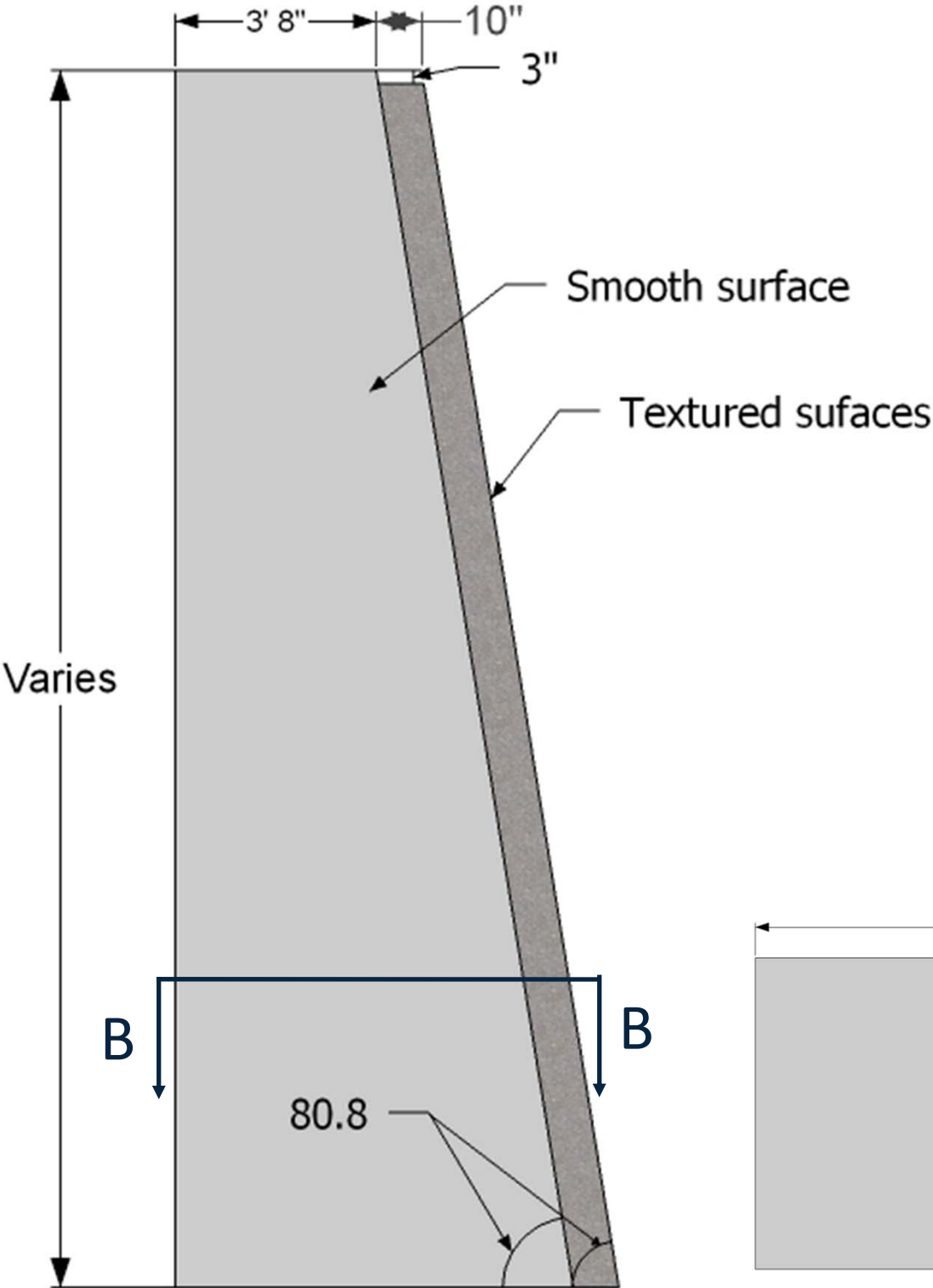

Elevation - Pilaster



Section B-B

Design Notes

- Style 2 (Edge) utilizes similar geometry and layout as base design
- Pilaster dimensions are common for all locations unless otherwise noted
- The base portion of the pilaster shall be constructed as a single piece as construction joints will not be allowed in either the horizontal or vertical plane.
- All chamfers on pilaster edges to be 1/2" maximum
- Texture to be 1/2" maximum .
- Depth of pilaster projection away from the adjacent wall may be reduced if roadway or track clearances dictate. Maintain a minimum of 1'-6"
- Provide separation of pilaster as required from face of bridge deck, parapet and adjacent wing wall or retaining wall.

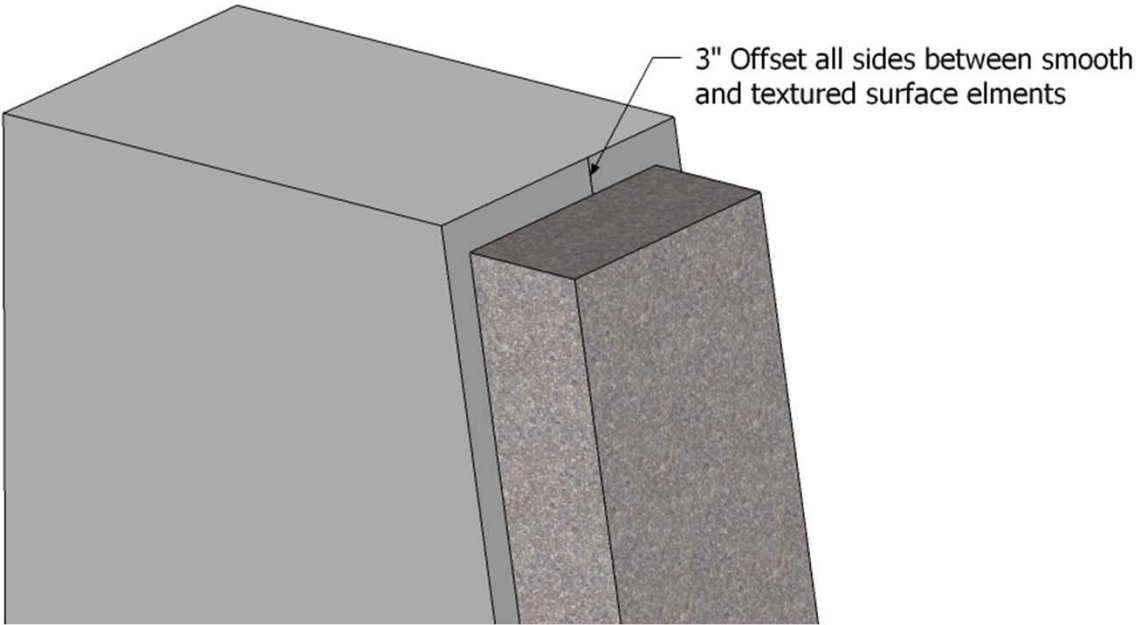

Partial Perspective of Pilaster Top

# 3.0.5 Abutment Pilaster: Style 2 (Edge) – Pilaster Pinnacle

Design Notes

- Style 2 (Edge) utilizes similar geometry and layout as base design
- Pilaster dimensions are common for all locations unless otherwise noted
- The base portion of the pilaster shall be constructed as a single piece as construction joints will not be allowed in either the horizontal or vertical plane.
- Depth of pilaster may be adjusted if roadway or track clearances dictate.
- All chamfers on pilaster edges to be 1/2" maximum
- Texture to be 1/2" maximum .

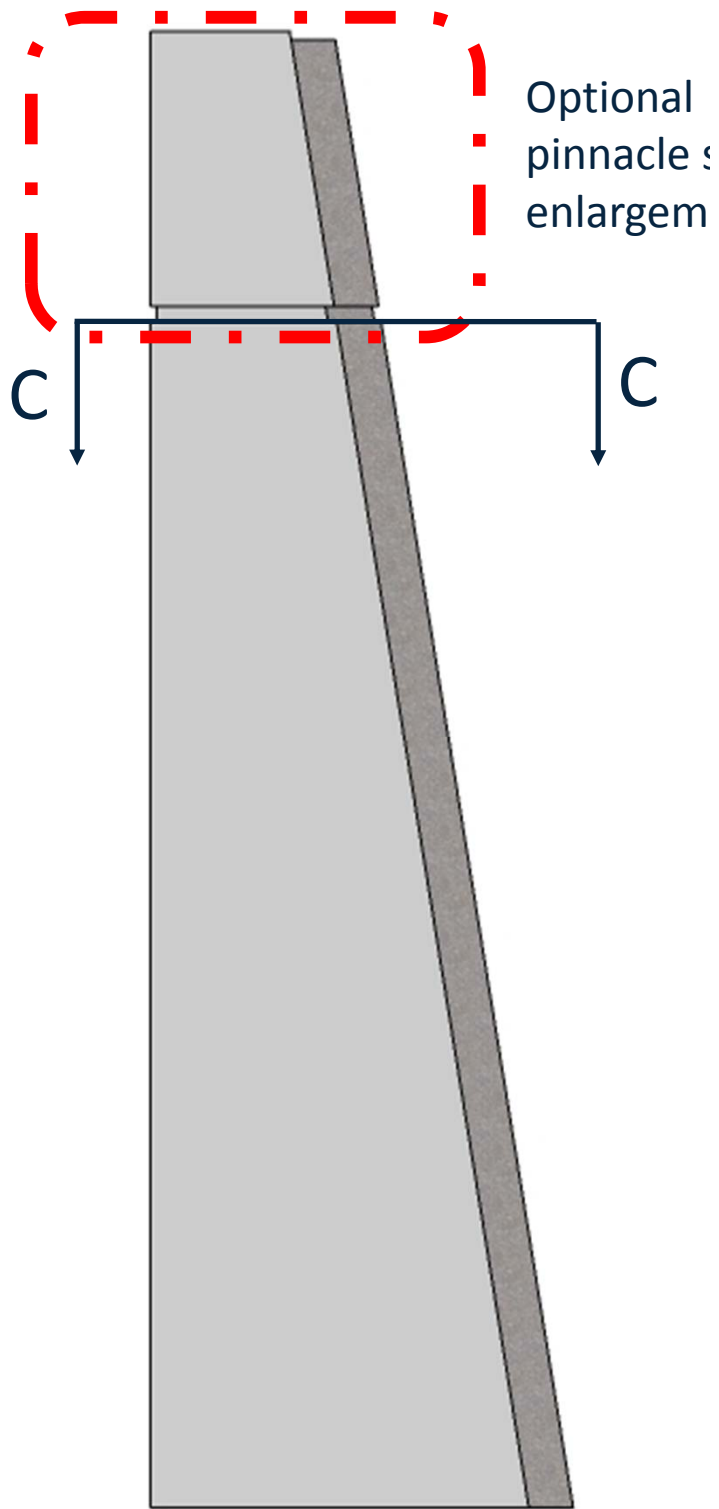

Pilaster Base w/ Pinnacle

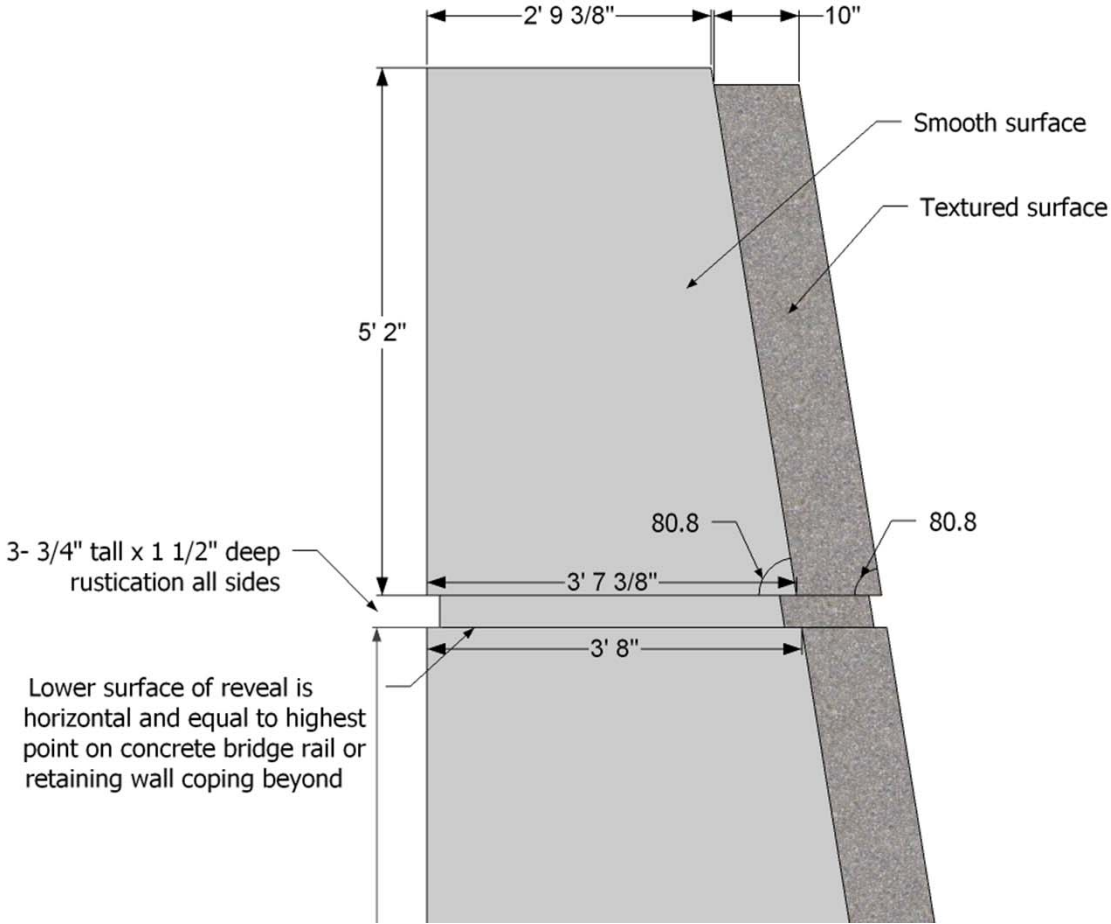

Elevation - Style 2 (Edge) Pinnacle

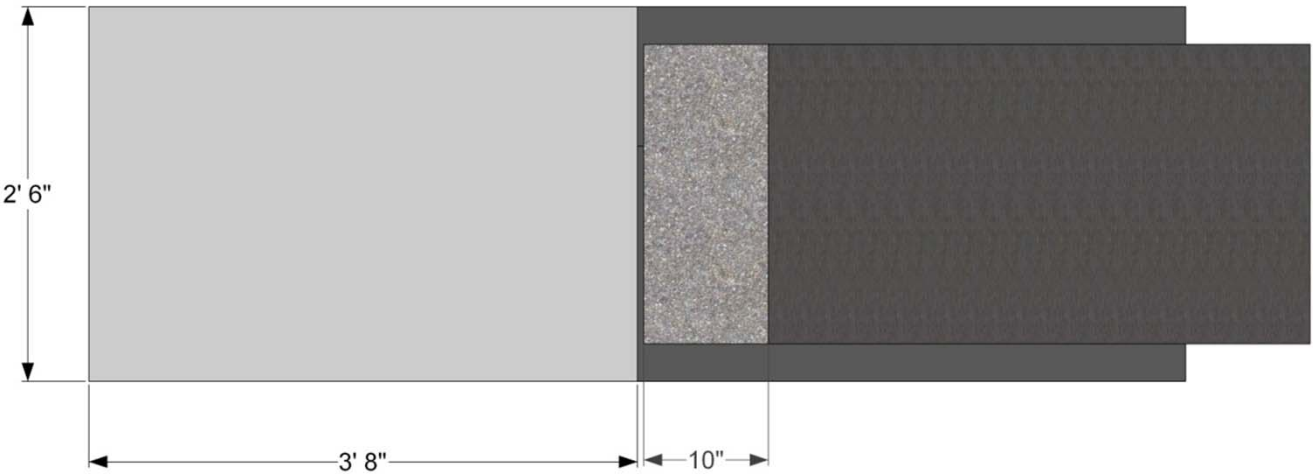

CC- Plan at base of reveal

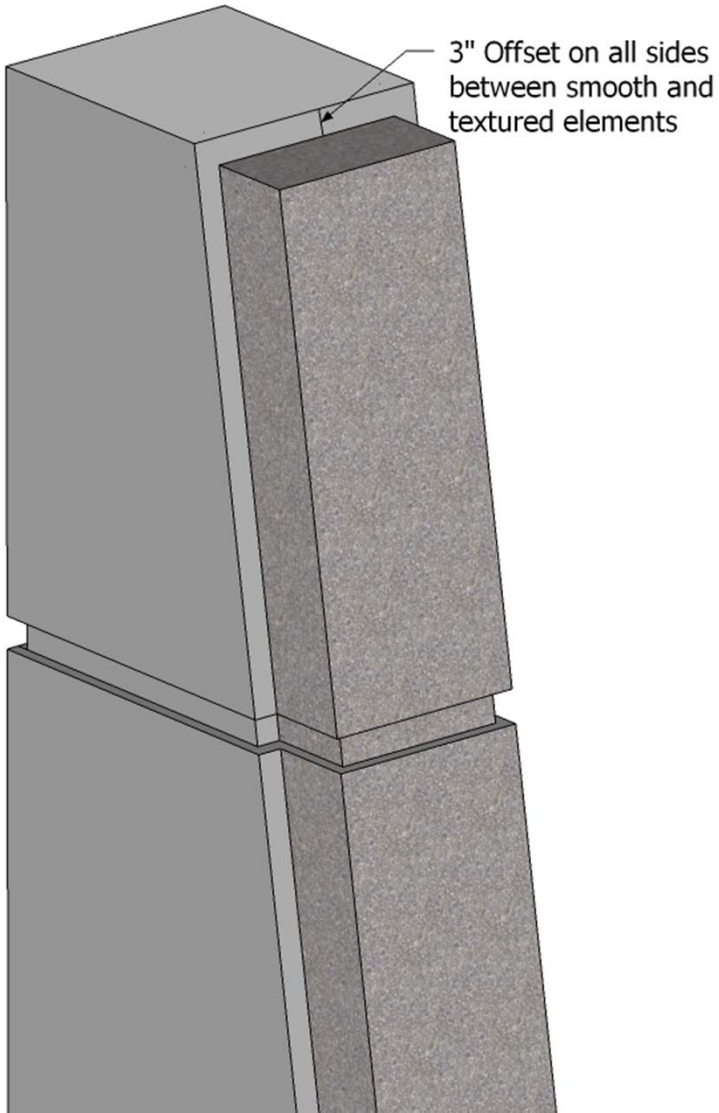

Perspective of Style 2 (Edge) Pinnacle



# 3.0.5 Abutment Pilaster LRT, FRT, TRL, Minnehaha Creek,

(minor structures prototype)

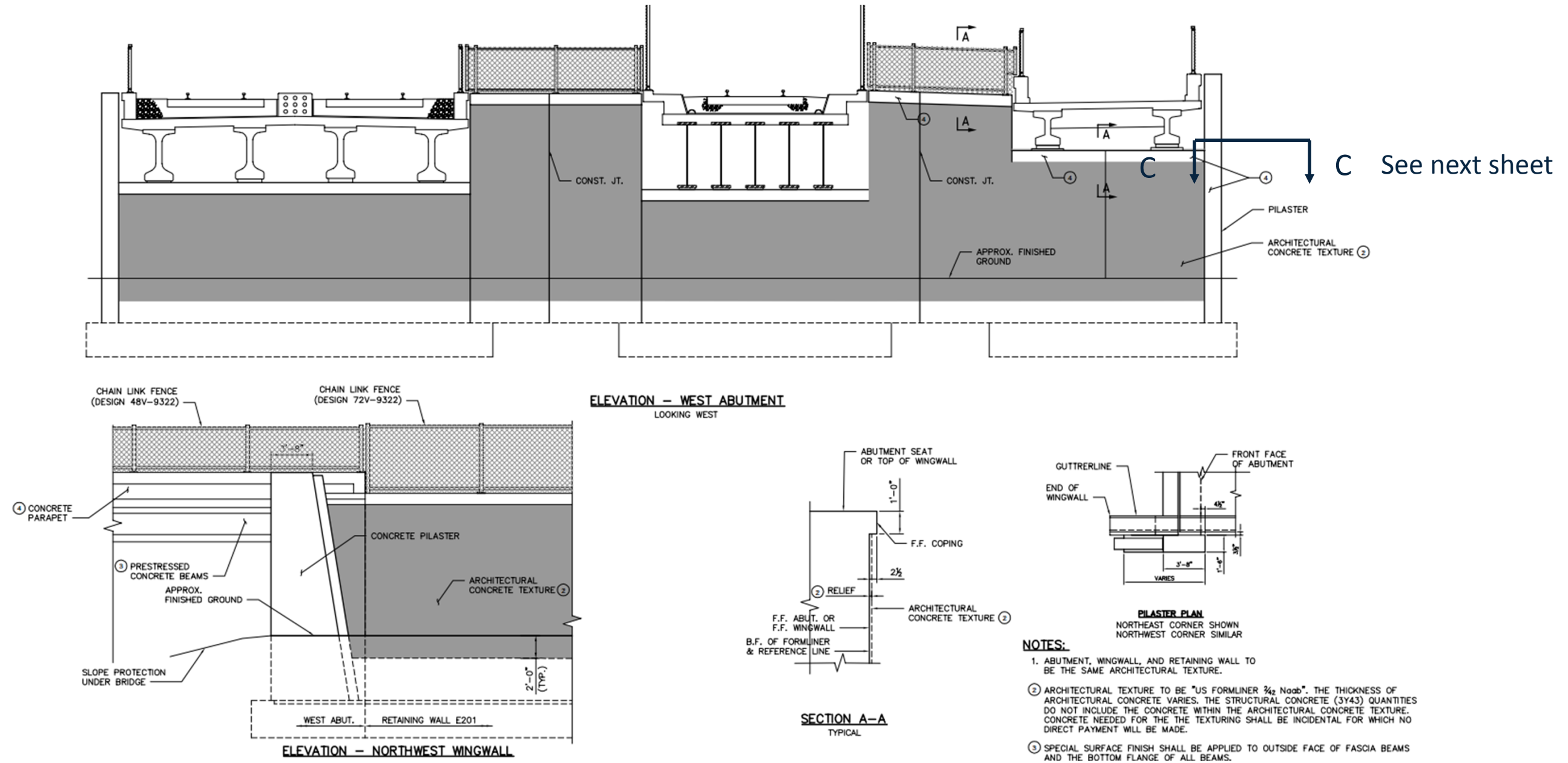

## Design Notes

- Both pilasters styles utilize similar geometry and layout.
- Pilaster dimensions are modified for smaller bridge structures as identified above.
- The base portion of the pilaster shall be constructed as a single piece as construction joints will not be allowed in either the horizontal or vertical plane.
- All chamfers on pilaster edges to be 1/2" maximum
- Provide separation of pilaster as required from face of bridge deck, parapet and adjacent wing wall or retaining wall.
- Texture to be 1/2" maximum depth on edge elements.
- See Application summary for location of Style 1 (Frame) or Style 2 (Edge)

### 3.0.5 Abutment Pilaster LRT, FRT, TRL, Minnehaha Creek,

(minor structures prototype)

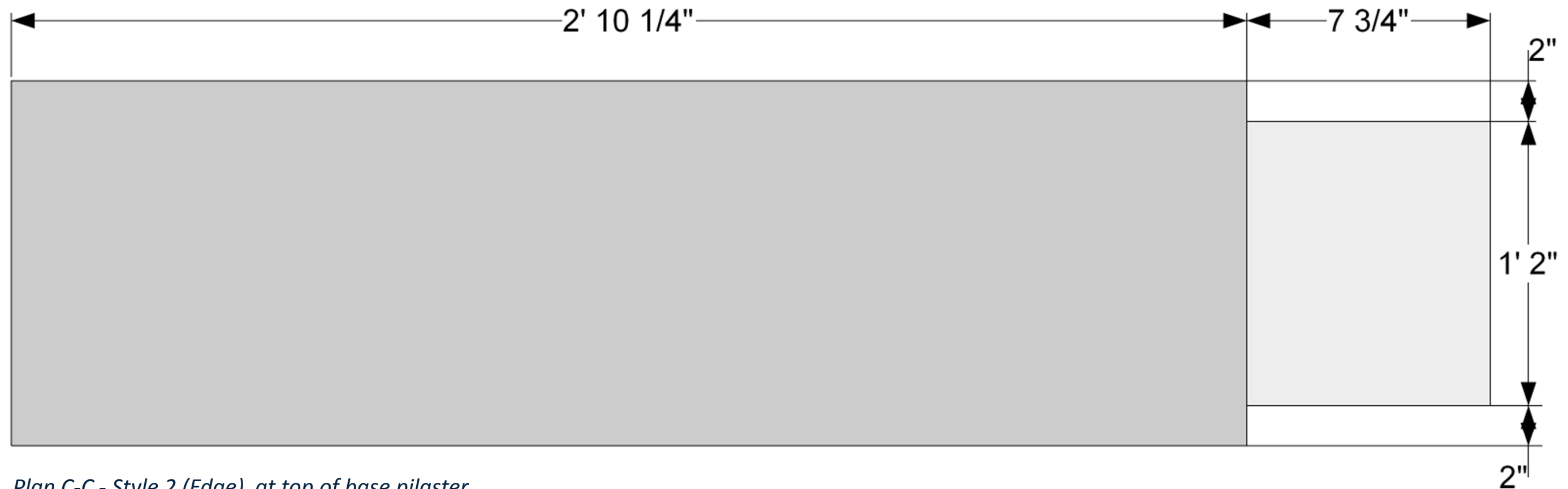

Plan C-C - Style 2 (Edge) at top of base pilaster

#### Design Notes

- Both pilasters styles utilize similar geometry and layout.
- Pilaster dimensions are modified for smaller bridge structures as Identified above.
- The base portion of the pilaster shall be constructed as a single piece as construction joints will not be allowed in either the horizontal or vertical plane.
- All chamfers on pilaster edges to be 1/2" maximum
- Provide separation of pilaster as required from face of bridge deck, parapet and adjacent wing wall or retaining wall.
- Texture to be 1/2" maximum depth on edge elements.
- See Application summary for location of Style 1 ( Frame ) or Style 2 (Edge)



# 3.0.5 Abutment Pilaster Concept Layout

Design Notes

- The base portion of the pilaster shall be constructed as a single piece as construction joints will not be allowed in either the horizontal or vertical plane.
- The concept image illustrates possible layout of Pilaster to achieve monolithic construction.
- Final design and detailing to achieve monolithic construction will be determined by structures design teams.

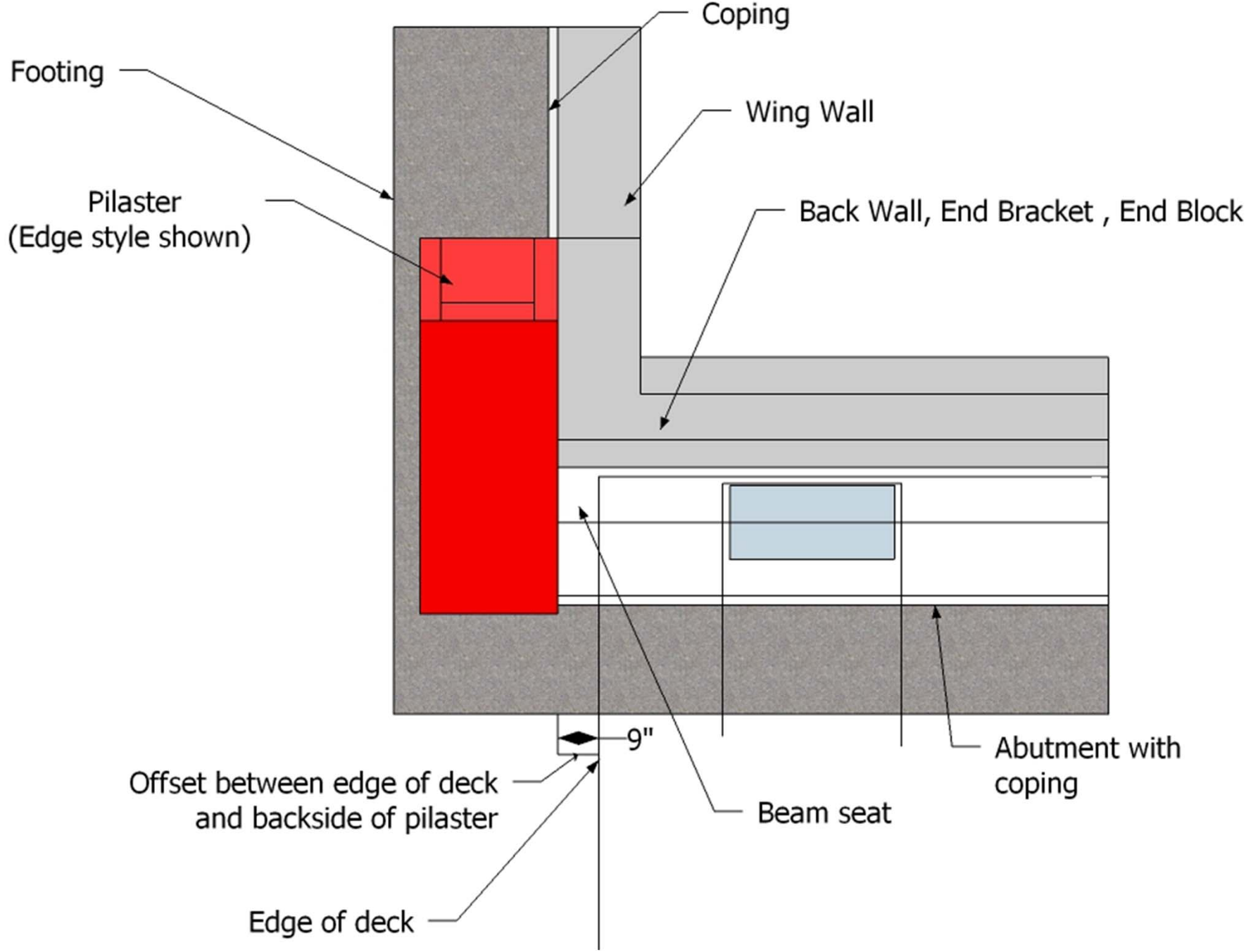

Plan View – Concept Prototypical Pilaster Layout ( Edge style shown, Frame style similar)

# 3.0.5 Abutment Pilaster LRT, EXCELSIOR LRT BRIDGE

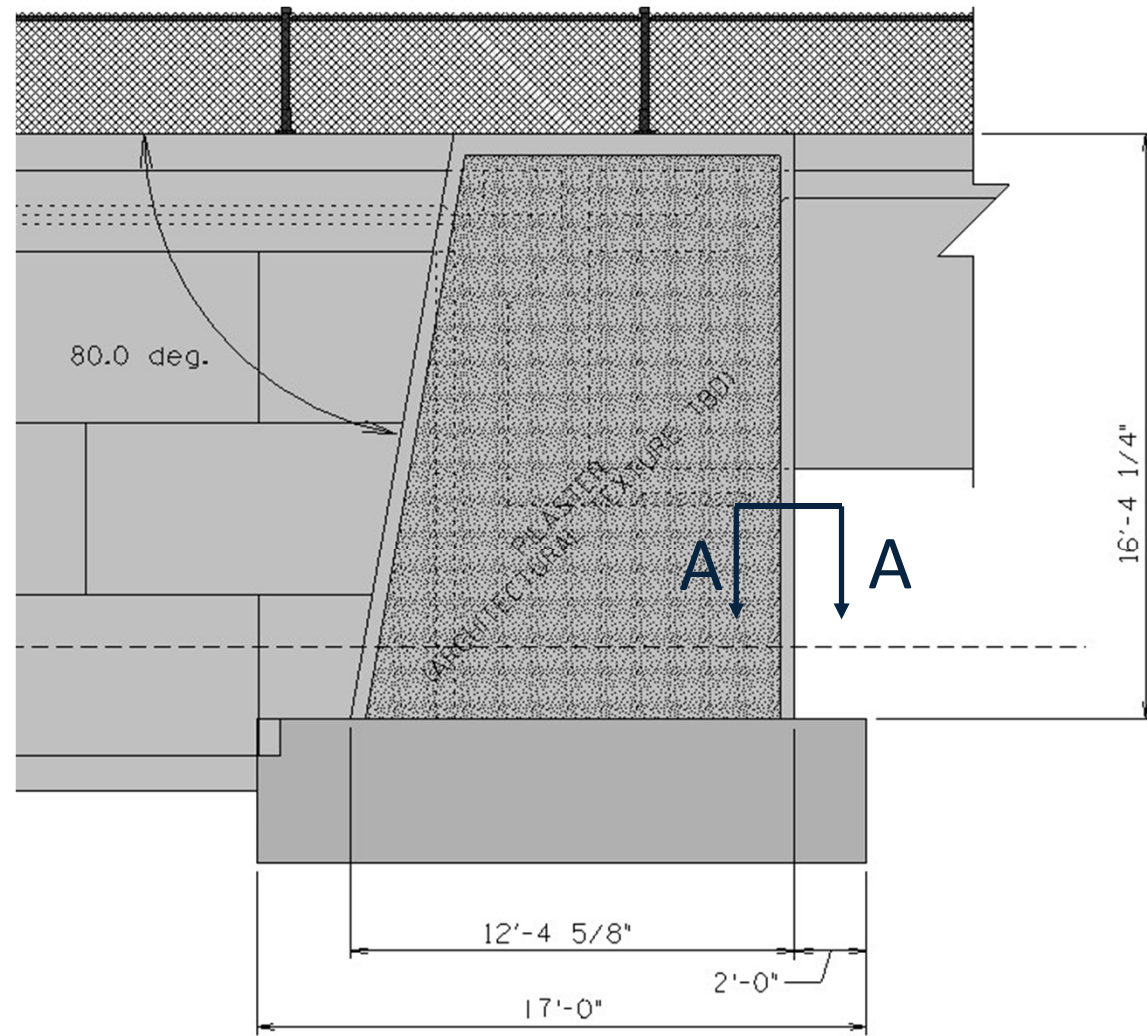

Elevation View - Pilaster

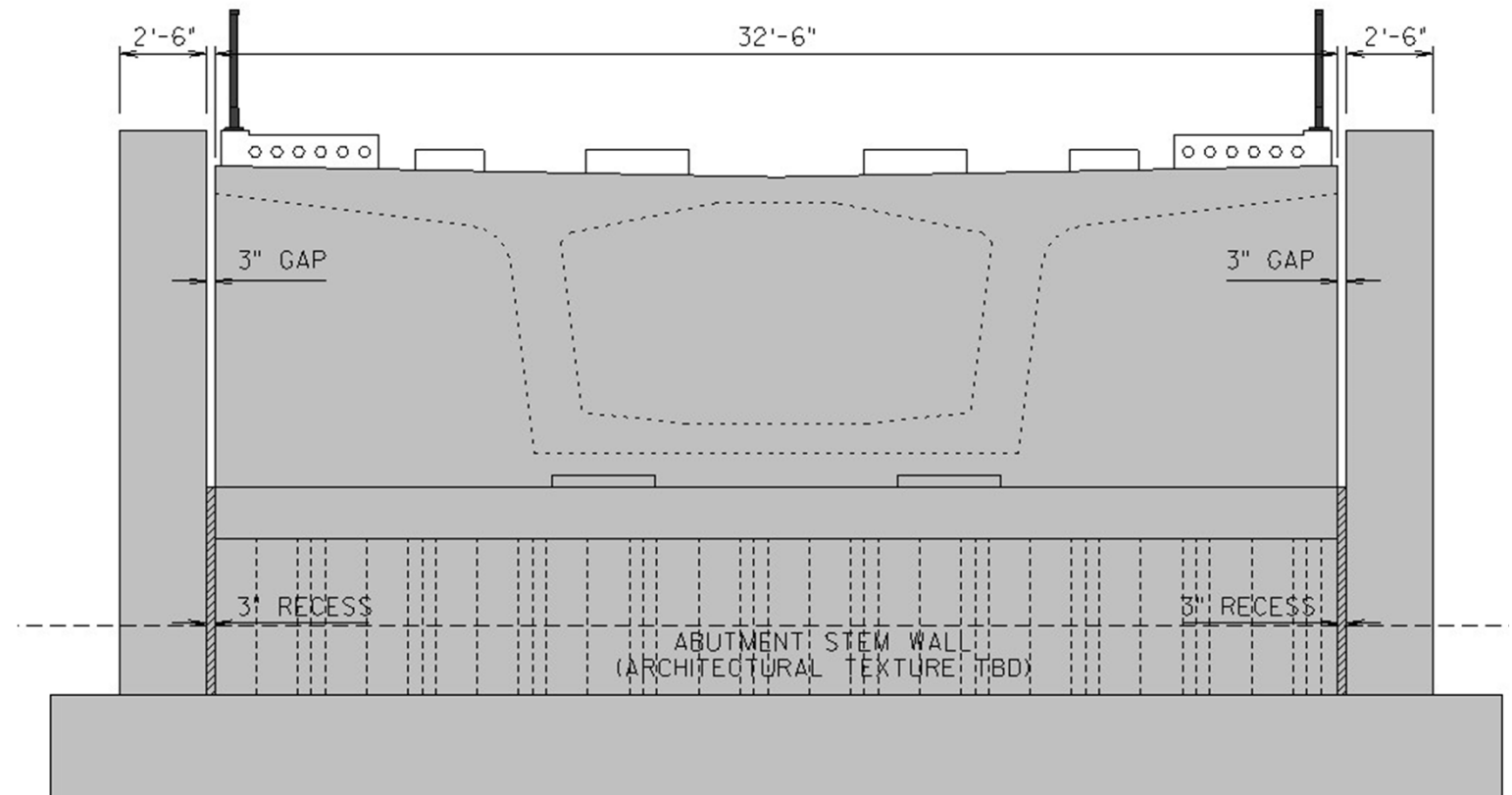

Elevation View- Abutment

### Design Notes

- Pilaster dimensions are modified for Excelsior Bridge as defined above.
- The pilaster shall be constructed as a single piece as construction joints will not be allowed in either the horizontal or vertical plane.
- Depth of pilaster projection away from the adjacent wall may be reduced if roadway or track clearances dictate. Maintain a minimum of 1'-6".
- All chamfers on pilaster edges to be 1/2" maximum.
- Texture to be 1" deep maximum.
- Style 1 (Frame)

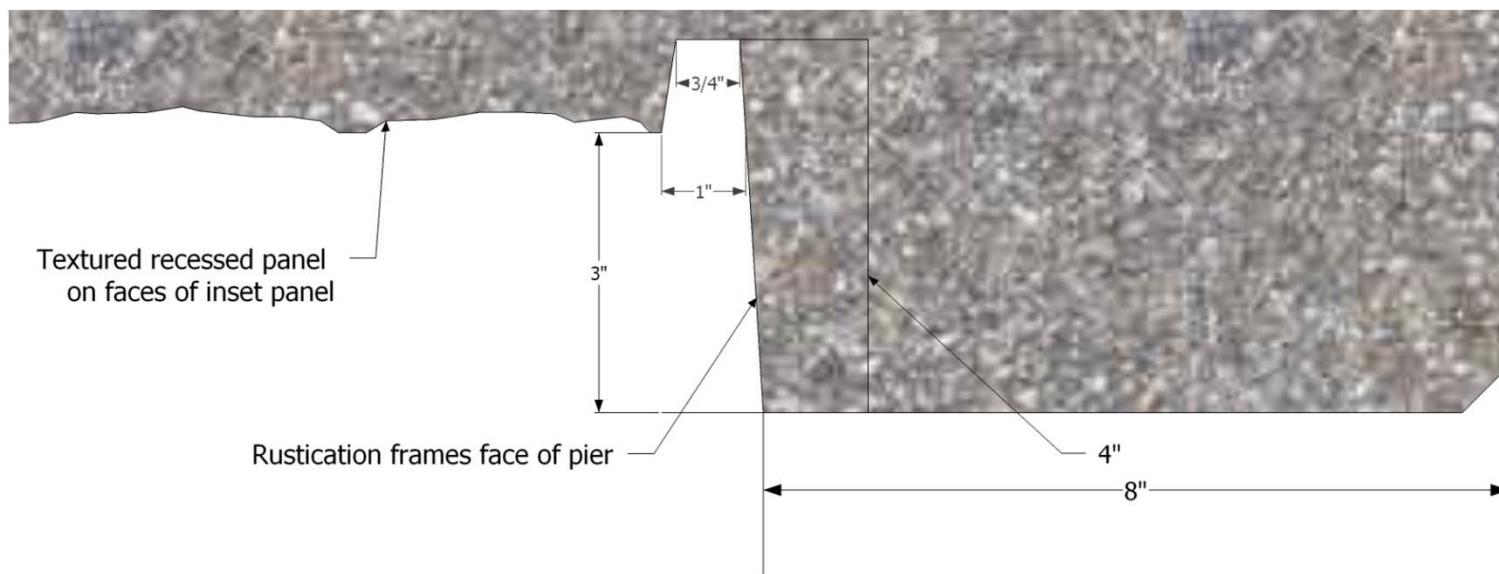

Partial Section A-A through edge of pilaster face.



### 3.1.1 Shady Oak –T.H. 212 LRT- T.H. 212 Existing Aesthetic Treatment by Element

The LRT bridge over Shady and T.H.212 will receive similar aesthetic treatments as other bridges in the corridor. The following images are representative of the types of treatments which are to be applied to the LRT bridge. The specific recommendations for aesthetic treatment are summarized in section 3.1.6.



*Example of Pier Shaft Treatment*



*Example of Wing Wall/ Abutment Treatment*



*Example of Pier Cap Treatment*



# 3.1.6 Shady Oak LRT-T.H. 2112 - Base Aesthetic Treatments - Wing Wall / Abutment

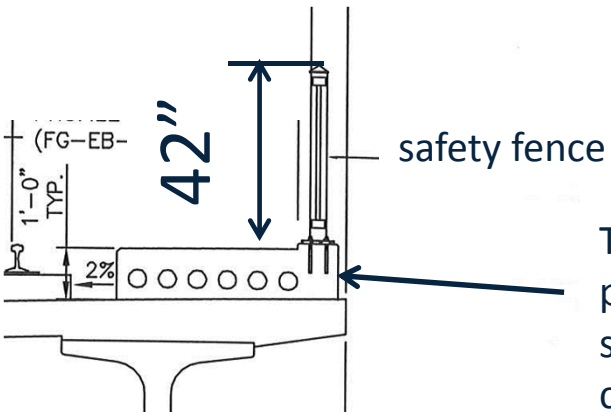

T.H. 212 Type 3 Architectural texture on parapet may not be feasible with shallow curb on LRT deck edge. Under continued study

Use #1 SWLRT Texture on abutment face and wing walls.

Aesthetics Recommended for Inclusion on Shady Oak LRT Abutments

- Use SWLRT #1 Texture on wing walls and abutment.
- Include standard wall coping on abutment face.
- Modified Eden Prairie Pillar as indicated

Include abutment pillar to top of concrete bridge rail 5'4" wide by 1'-10" deep.

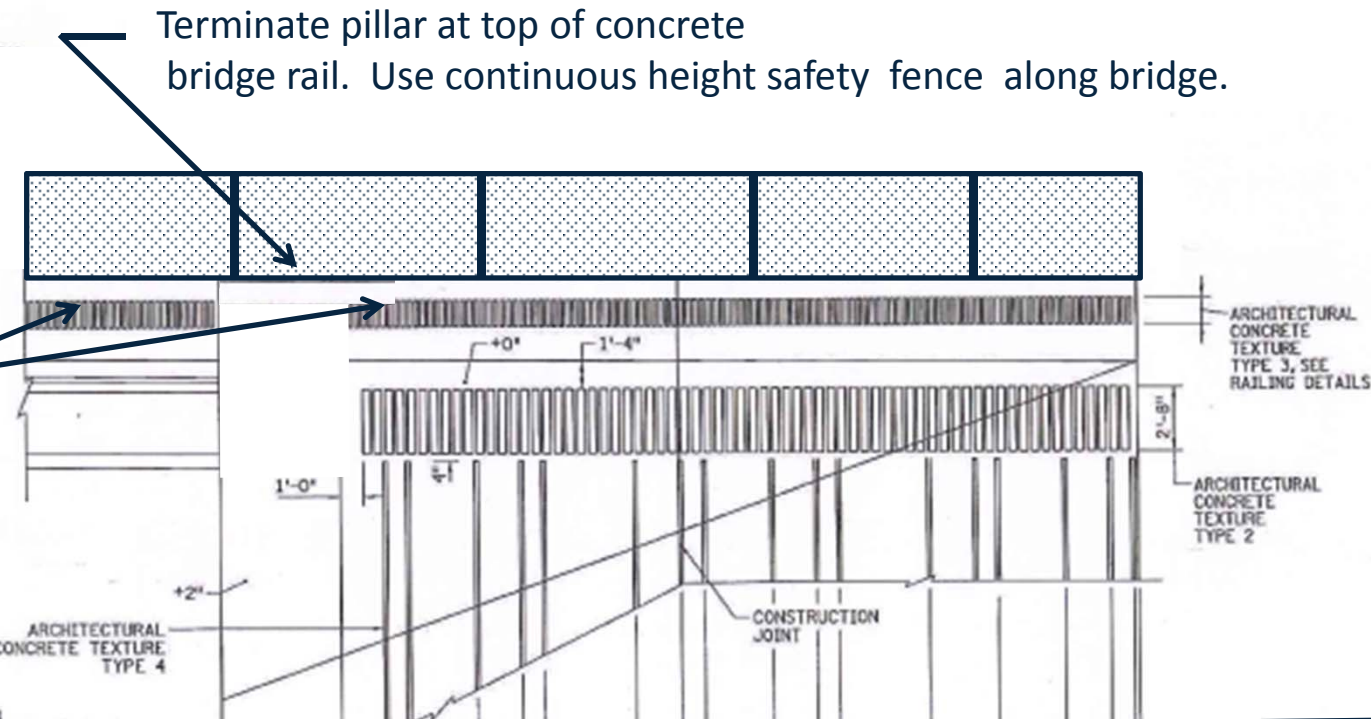

Example of smaller scale bridge abutment with 212 treatment suitable for LRT bridge abutment and wing walls.



### 3.1.1 Shady Oak –T.H.212 LRT - Summary of Treatments to Pier Caps

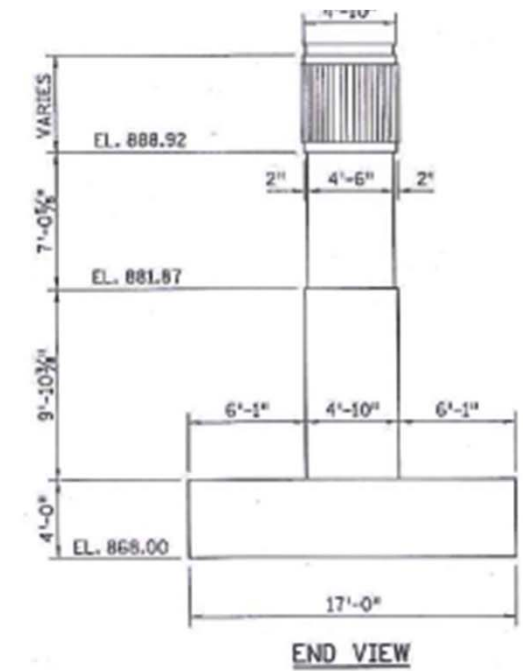
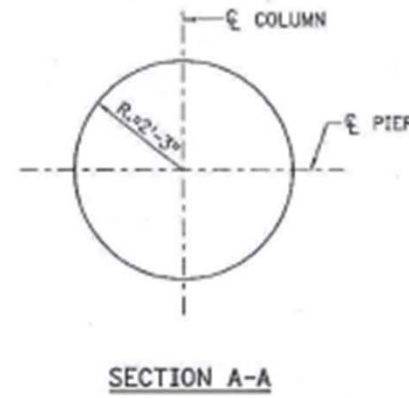
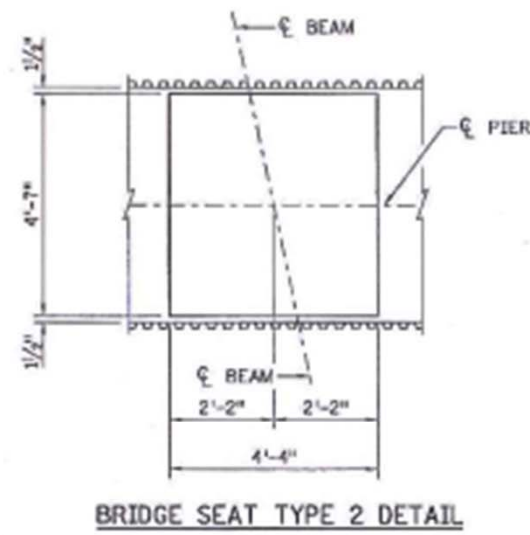
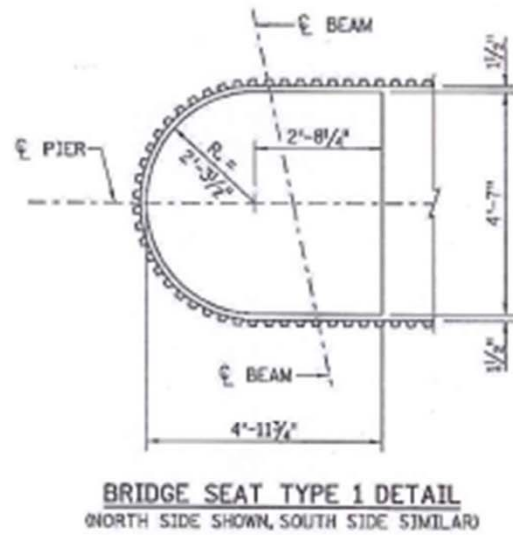
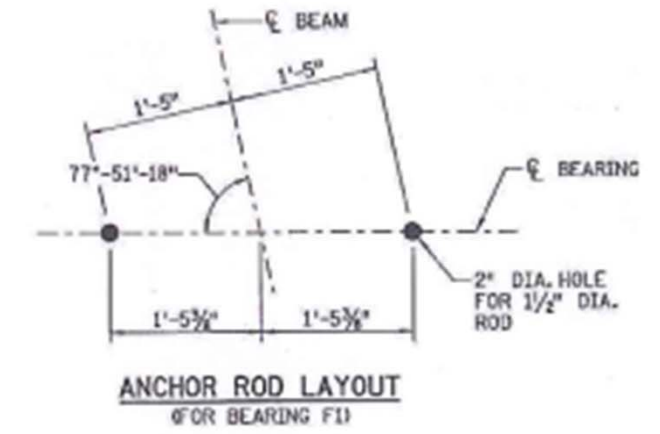
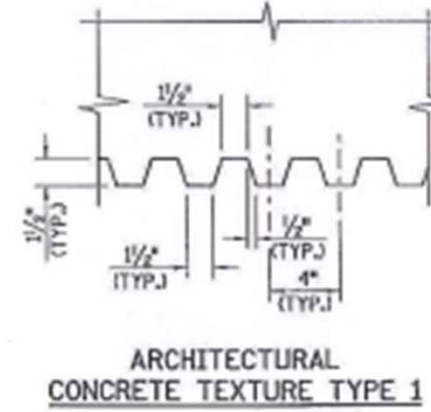
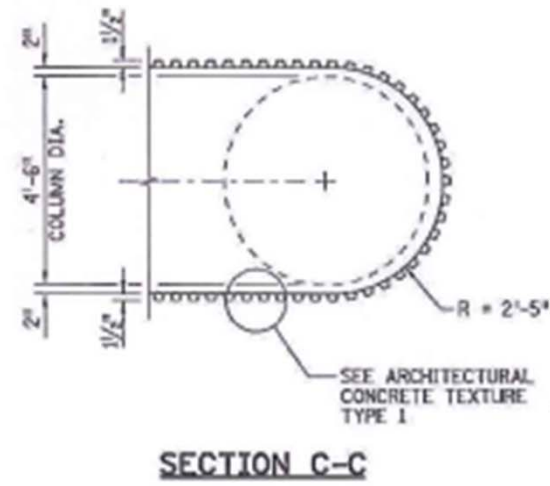
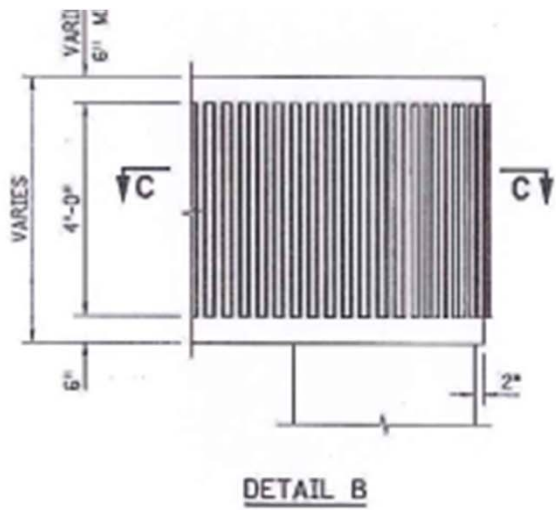

#### Design Notes

- To the greatest extent possible, follow the T.H. 212 Design Aesthetics piers.
- The standard 4'-0" height of Architectural Concrete Texture Type 1 on LRT Piers located within the T.H. 212 R.O.W. may need to be reduced to fit within critical height restrictions for future roadway build out.
- Final height of texture to be determined based upon final LRT bridge alignment and profile.

### 3.1.1 Shady Oak –T.H.212 LRT - Summary of Aesthetic Treatments to Piers and Railing

#### Design Notes

Base aesthetic elements on the LRT bridge spans include:

- T.H. 212 Cylindrical pier shaft
- Radial surfaced pier cap end
- Vertical rib architectural treatment on pier cap
- 212 base color
- Accent color on outside girders
- Continuous height safety rail



*Elevation of bridge with T.H. 212 color palette with diamond mesh safety rail.*



*Pier End View*

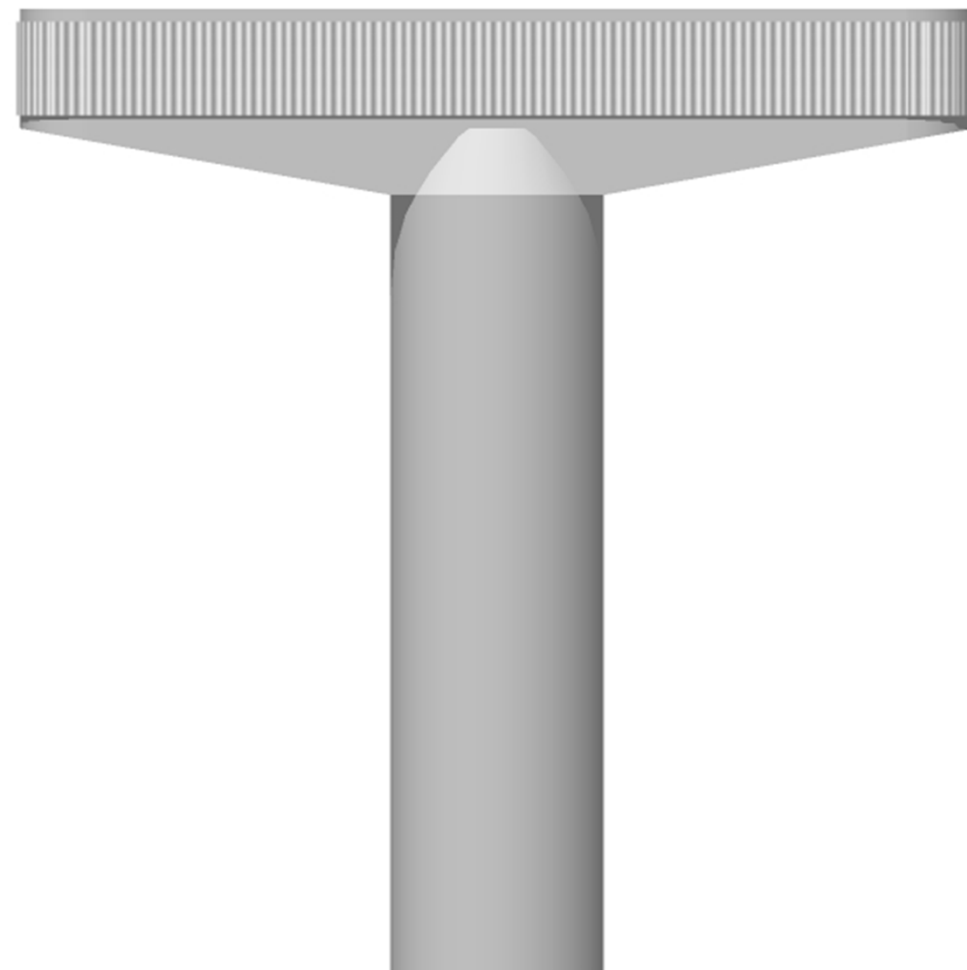

*Pier Elevation View*

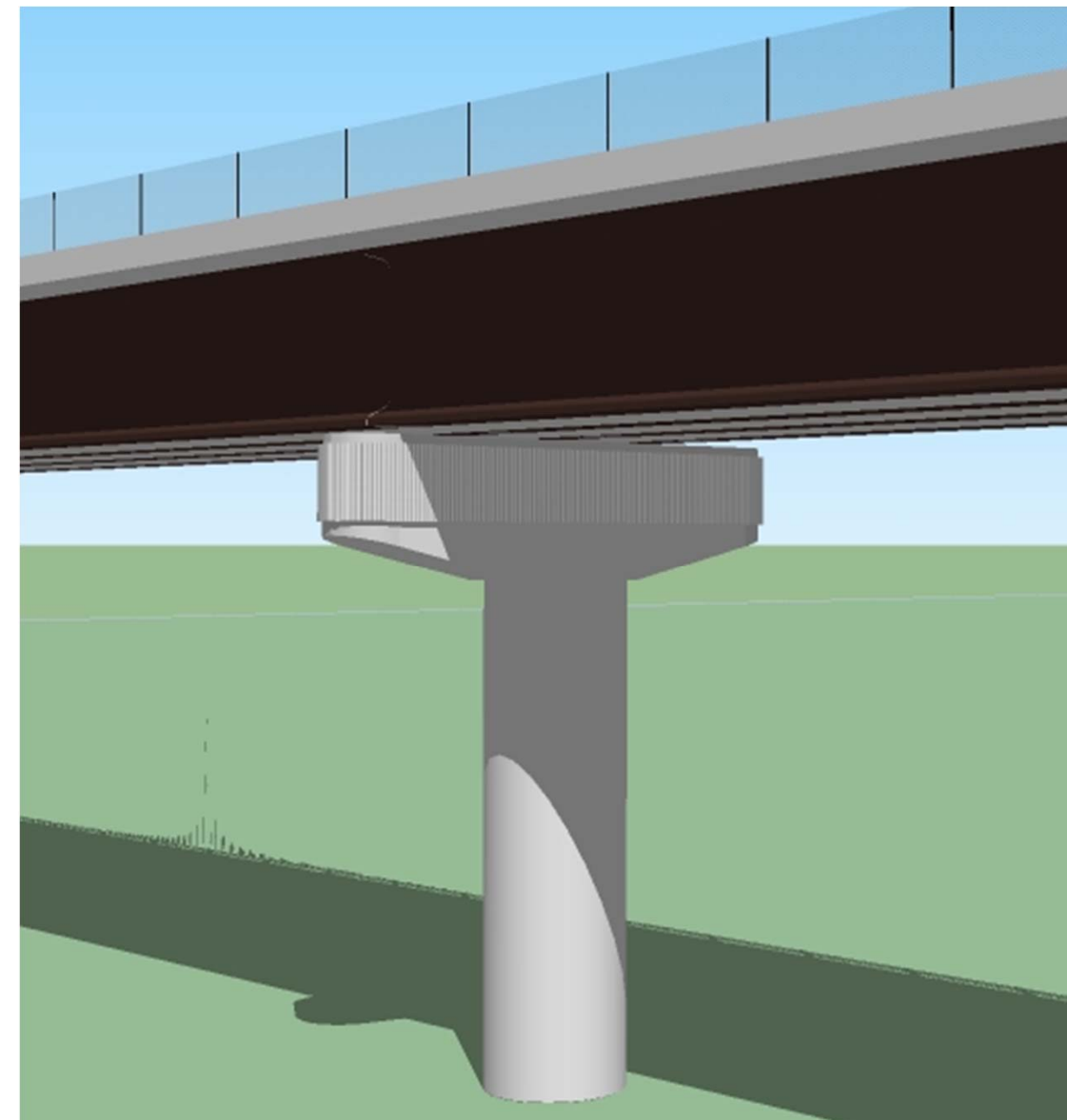

*Perspective view- Pier with T.H. 212 aesthetic treatment and project standard safety rail.*



## 3.1.2 Aesthetic Treatments LRT over I-494



*Elevation – Abutment , Wing Wall/Retaining Wall*

### Design Notes

- The LRT bridge over the I-494 corridor will follow the MnDOT I-494 corridor aesthetic treatment as detailed proximate to the 169 corridor.
- Washington Ave. South is the prototype for aesthetic features except as follows:
- The aesthetic treatments will be modified to include diamond mesh safety fencing on bridge to maintain parity with other structures in the SWLRT project.

**Aesthetic Approach  
Under Continuing Study  
TBD**



*Perspective – Center Pier*

### 3.1.3 Vehicle Bridges at Glenwood Ave.

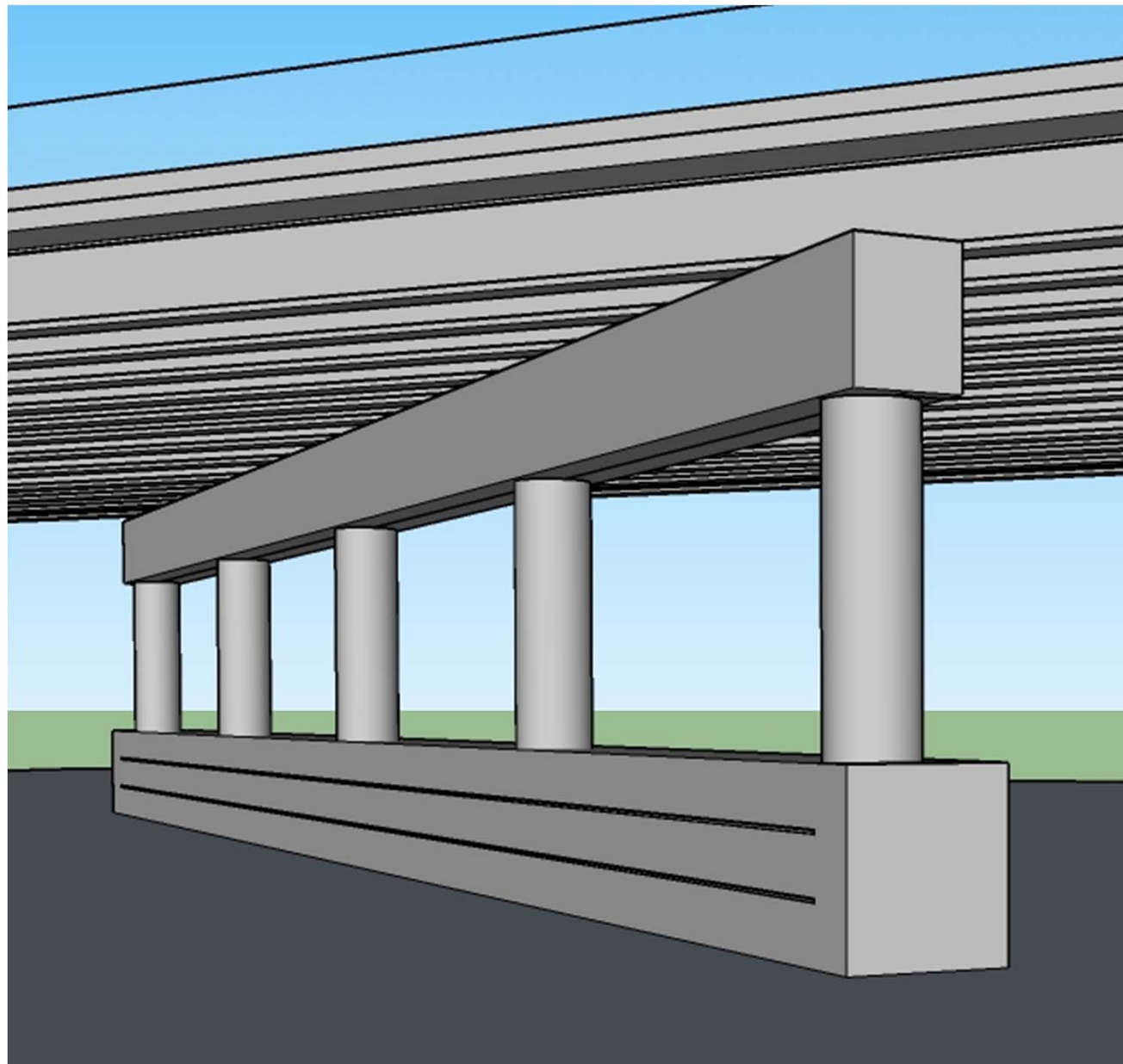

#### Design Notes

- The vehicle bridge substructure to be constructed using rectangular cap and cylindrical columns. At the base of the columns a continuous crash protection wall is required.
- Crash protection structures shall be sized and detailed per applicable standards.
- Horizontal aesthetic reveals (equal horizontal spacing) are to be included in the face of the crash barrier.
- Glenwood Ave. only to use square end crash wall.
- See Crash Protection section for reveal details.
- Use standard safety railing for base design.

*Perspective of representative column and crash wall for use on Glenwood Ave. vehicle bridges– Center Pier  
Abutment wall treatment See 5.1.2 Retaining Wall Section*



### 3.1.3 LRT Bridge at Glenwood Ave.

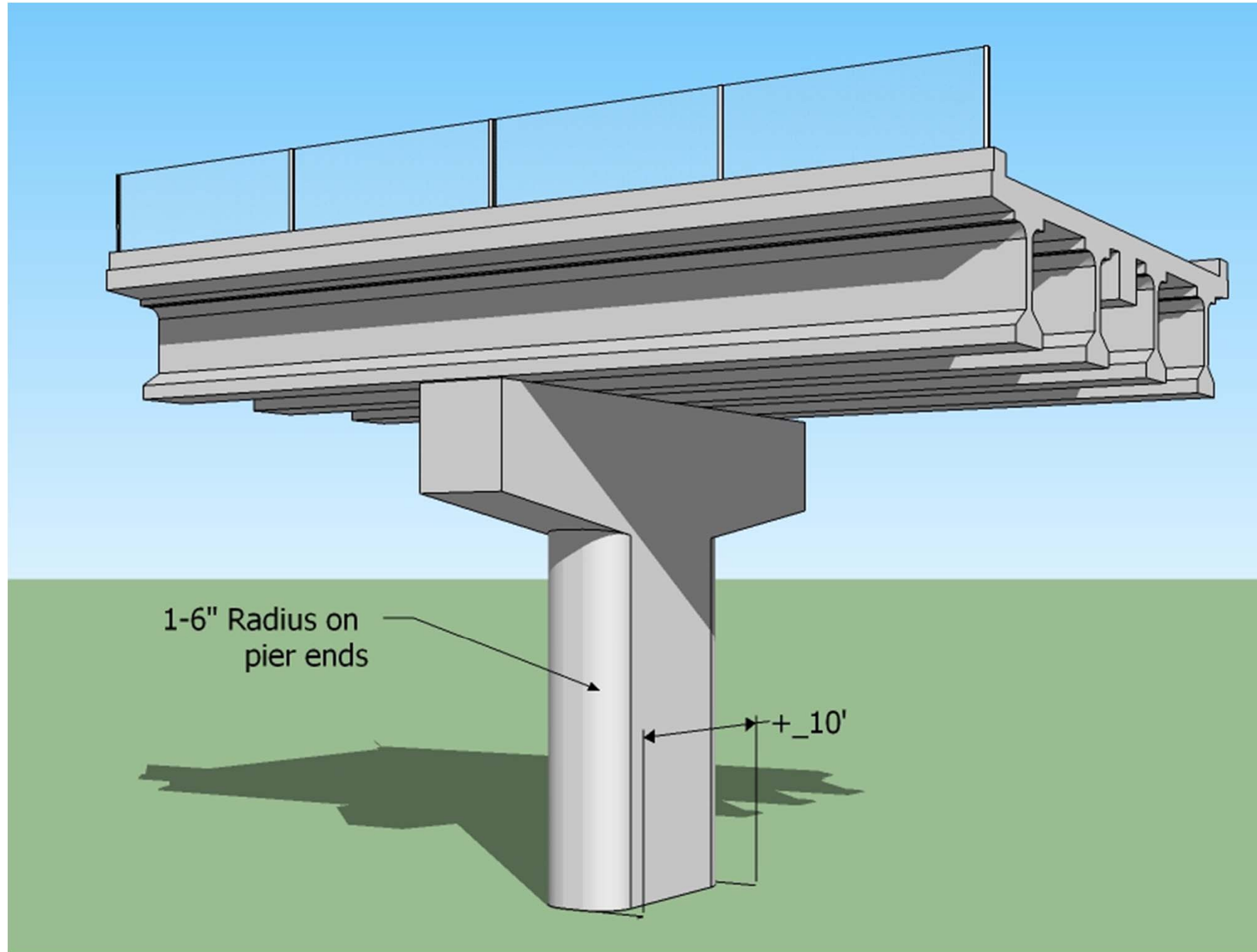

*Perspective of representative pier for LRT Bridge Piers 1-8*

#### Design Notes

- The vehicle bridge substructure to be constructed using Hammer Head Pier.
- Cap arm angle to shaft to follow standard details with flat sloped undersides.
- Pier shaft ends are to be finished with 1'-6" radius surfaces to match radius of Glenwood Ave. vehicle bridge columns.
- No surface rustications to be used on pier.
- Shaft width +/-10' may be adjusted as required to achieve sufficient cross sectional area for monolithic crash protection
- Use standard safety railing for base design

### 3.1.3 LRT Bridge at Glenwood Ave.

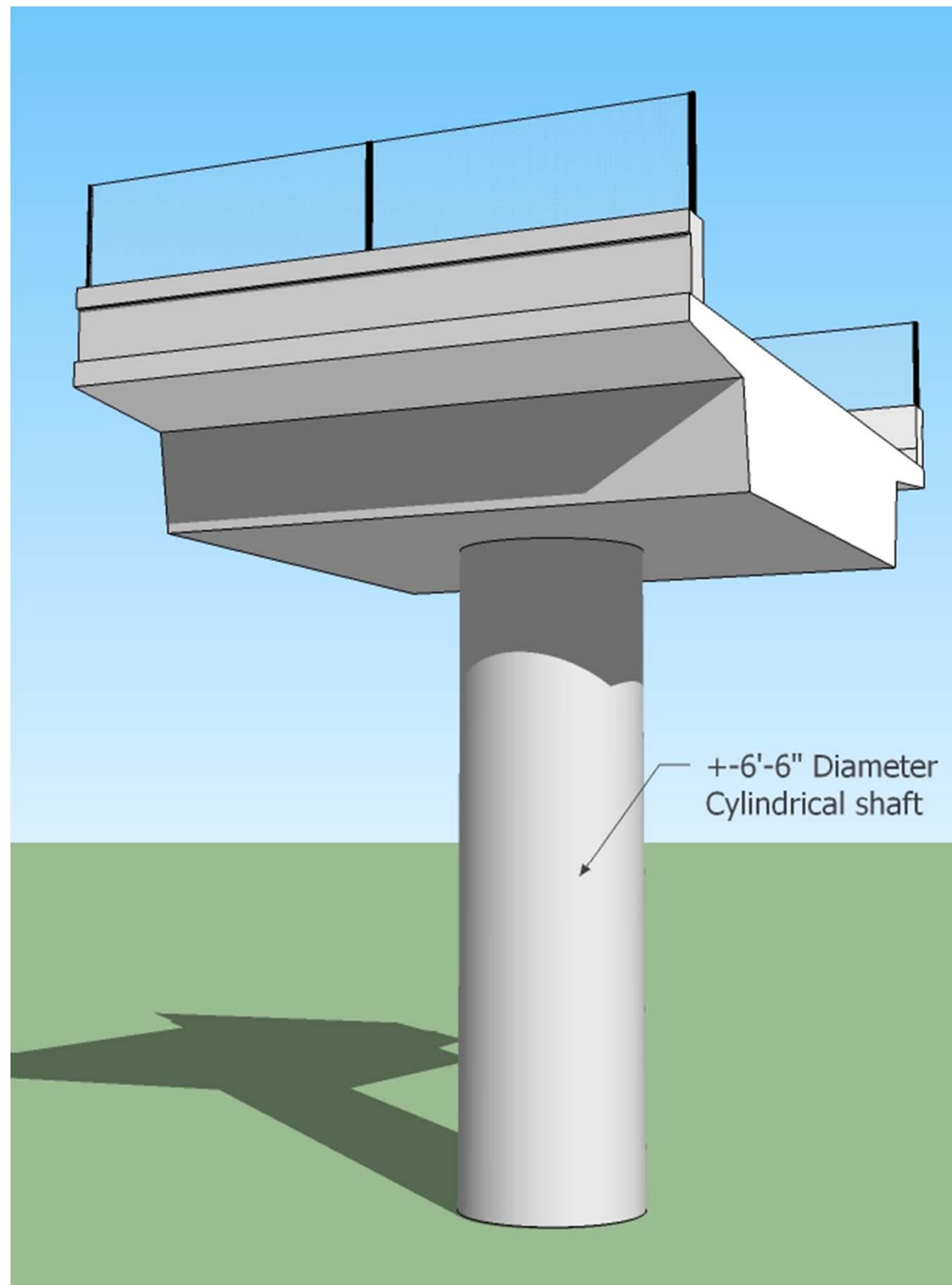

*Perspective of representative pier for LRT Bridge Piers 9-10*

#### Design Notes

- The LRT bridge substructure at this location to be constructed using monolithic cylindrical shaft.
- No surface rustications to be used on pier.
- Shaft diameter may be adjusted as required to achieve sufficient cross sectional area for monolithic crash protection
- Use standard safety railing for base design
- No surface textures on parapet.



### 3.1.4 LRT Bridge 5<sup>th</sup> and 7<sup>th</sup>



#### Design Notes

- The LRT bridge substructure at this location to be constructed rectangular caps ( tapered ends) and cylindrical shafts similar to the existing substructures at the Interchange.
- No surface rustications to be used on pier.
- Use standard safety railing for base design
- No surface textures on parapet.

*Perspective of representative design Pier 7-10 for east end of 5<sup>th</sup> and 7<sup>th</sup> LRT Bridge adjoining existing Interchange*

### 3.1.4 LRT Bridge 5<sup>th</sup> and 7<sup>th</sup>

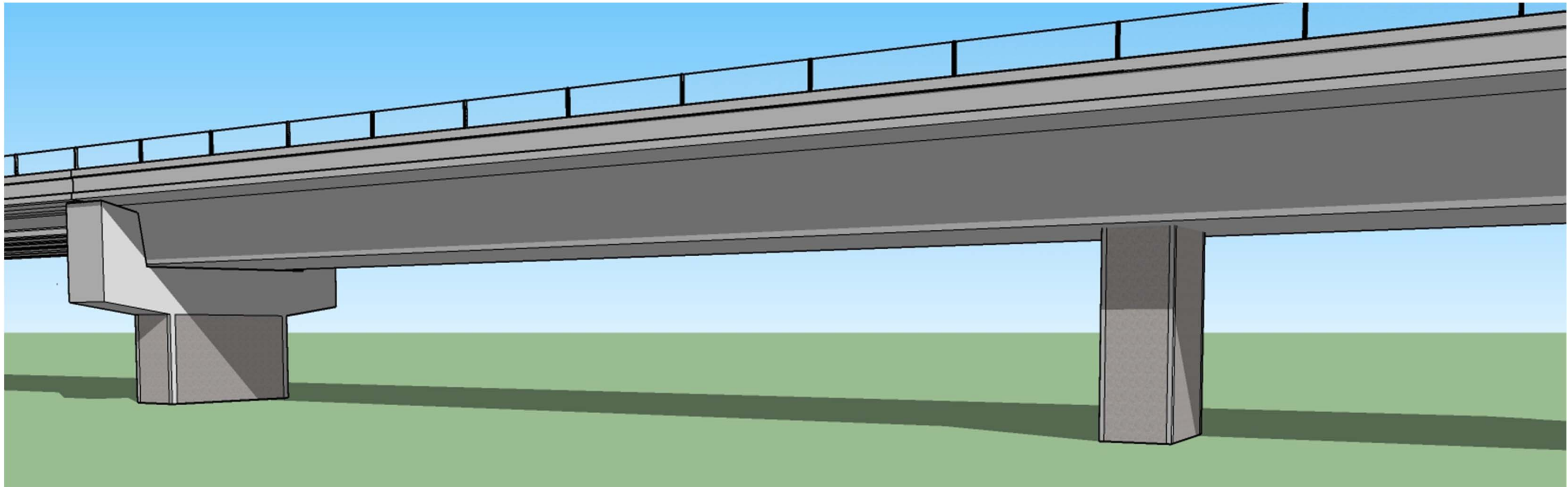

*Perspective of representative for LRT Bridge-  
Piers 1, 6 Transitional Pier*

*Perspective of representative for LRT Bridge-  
Piers 2-4 Monolithic Pier*

#### Design Notes

- The LRT bridge substructure at this location to be constructed using monolithic rectangular shafts integral with the box girder
- Transition piers provide support for both conventional concrete girders and concrete box girders
- Minimal surface texture on faces of piers framed by 6" smooth band.
- Use standard safety railing for base design
- No surface textures on curb/parapet.



### 3.1.4 LRT Bridge 5<sup>th</sup> and 7<sup>th</sup>

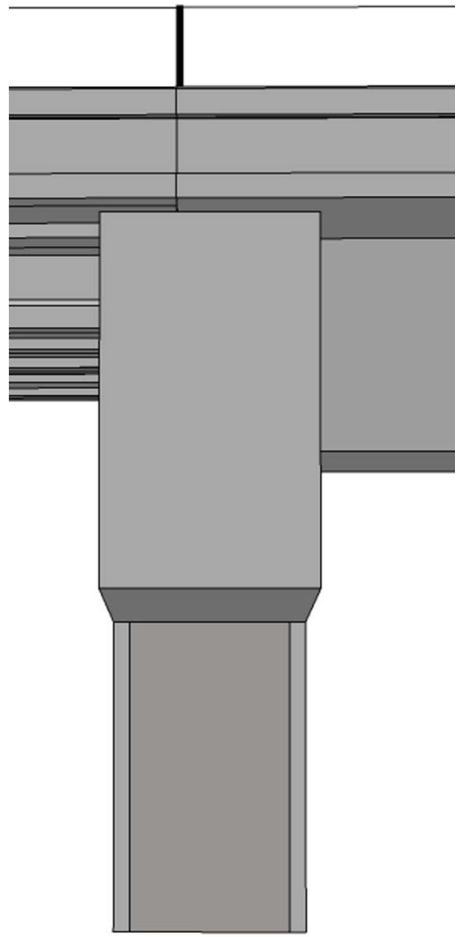

*Transition Pier  
End View*

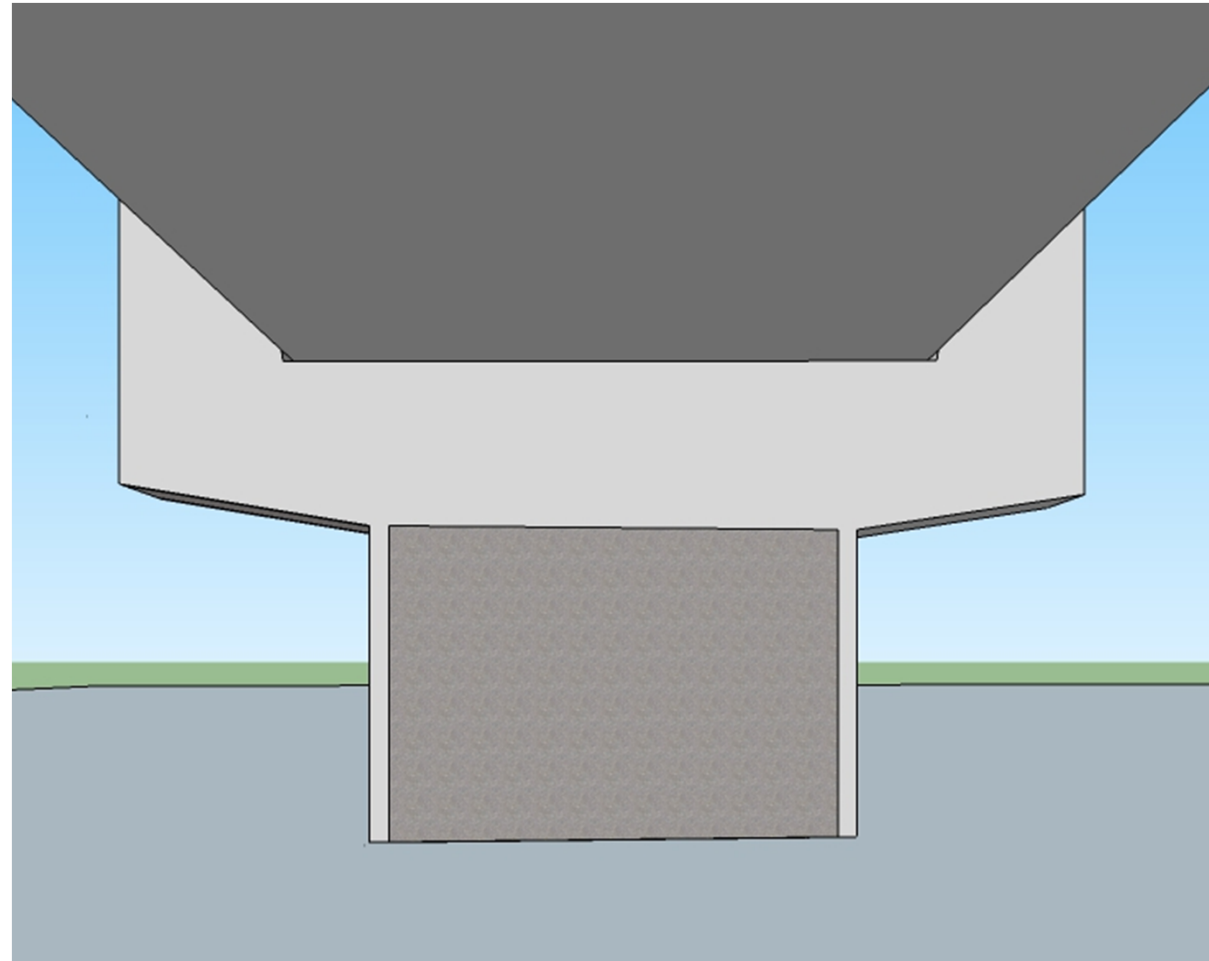

*Transition Pier – Elevation View PCC Girder side*

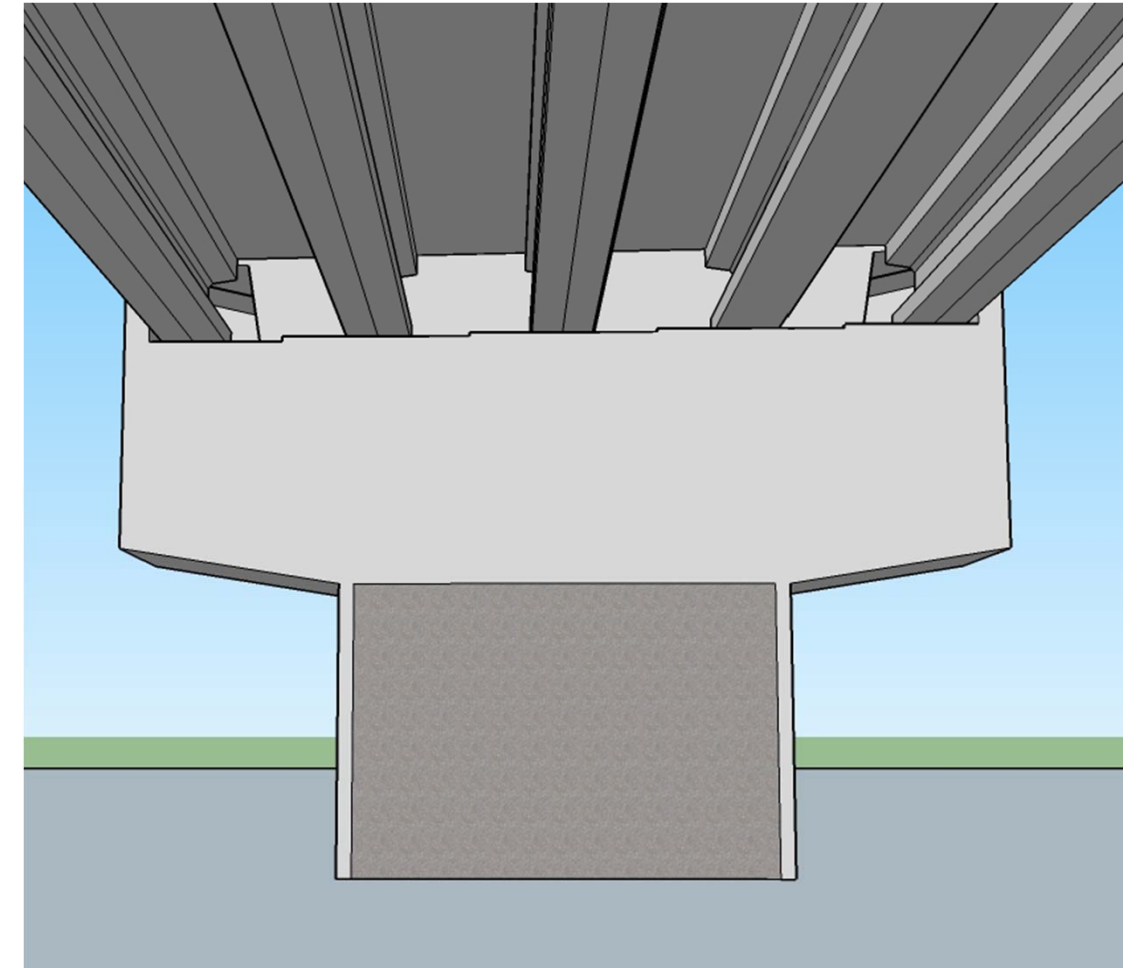

*Transition Pier – Elevation View box side*

### 3.1.5 Pier Crash Protection



*Extensive existing pier protection beneath I-394 with simulated crash protection walls.*



*Extensive existing pier protection beneath I-94 with simulated crash protection walls.*

The existing piers supporting I-394 and I-94 within the LRT/ FRT corridor vertical wall pier protection between the piers. The proposed LRT improvements in the heavy rail corridor will necessitate the addition of new pier protection to a number of the vehicle bridge piers which already have protection in place. The additional protection required is taller than that which is currently in place. The height of the new protection barriers will be visible from the LRT vehicles and the adjacent trail. The heights of required protection walls varies depending upon distance from the LRT rail with those closest requiring walls 12' above track height and those furthest requiring walls 6' above track height. Due to the extent of the existing pier protection already in place, the limited additional protection required, a series of horizontal reveal is proposed for surfacing of all new crash walls in the I-394/I-94 LRT corridor. In addition, the application of anti graffiti coating is recommended on crash wall surfaces. See continuation of this section for wall treatment details.

See summary recommendations for surface treatment to crash walls in other portions of the LRT corridor.



### 3.1.3 Pier Crash Protection - I-94/I-394

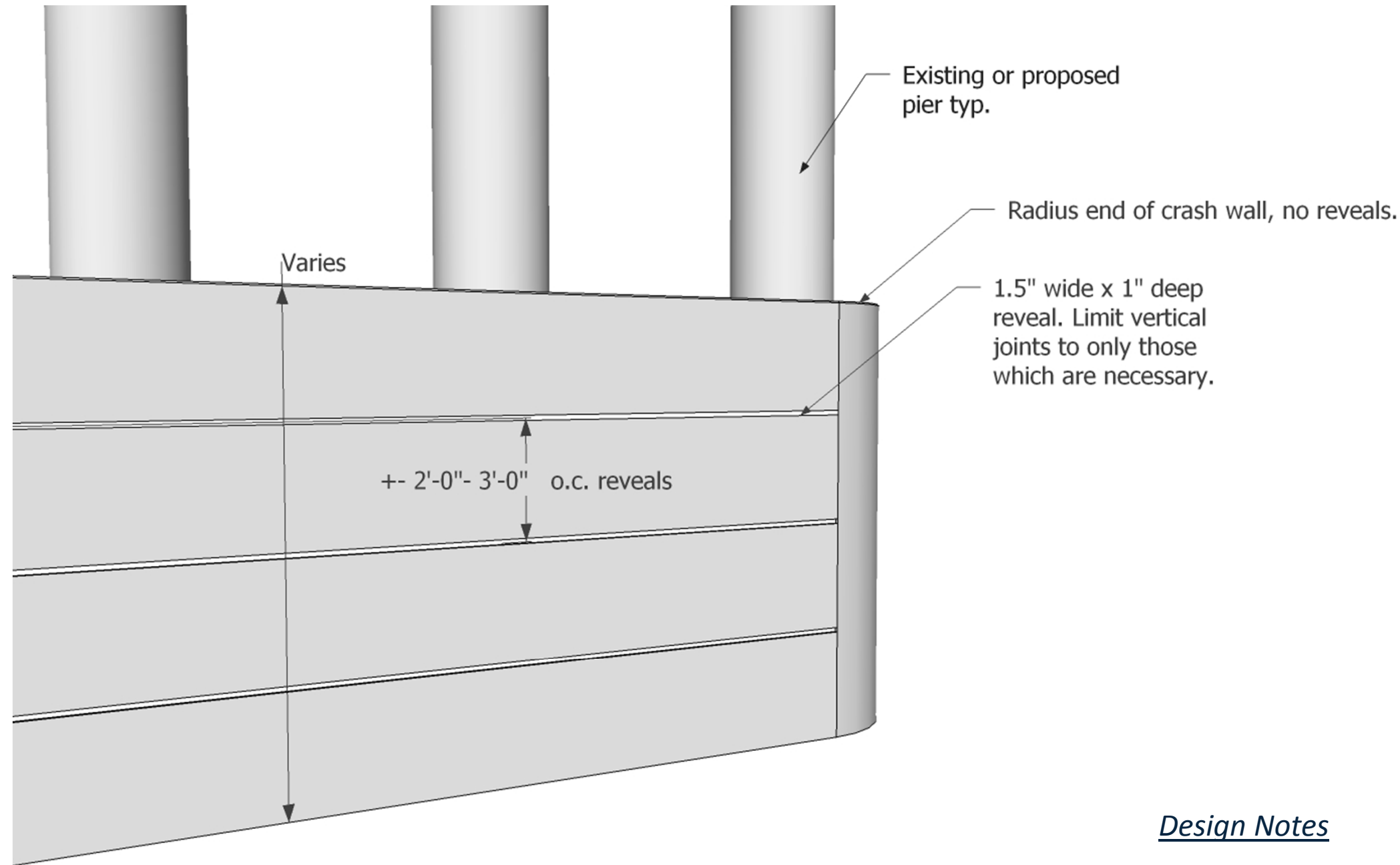

*Horizontal Reveal Treatment*

#### Design Notes

- Within the I-394 and I-94 LRT corridor apply simple horizontal reveals as detailed above.
- Layout necessary vertical wall joints first, minimizing the number to only those required. Reduce visual presence of vertical joints as much as possible by limited depth of chamfer. Apply color matched sealant over expansion material to conceal contrasting color.
- Attempt to use similar aesthetic reveal spacing for all new crash walls regardless of wall height.
- Ends of crash walls to be formed in radius shape to match existing piers. Preferred.
- Finish top edge of crash walls and end with  $\frac{3}{4}$ " chamfer.
- Coat areas prone to graffiti with clear anti-graffiti coating

### 3.1.3 Pier Crash Protection – Van White Memorial Blvd.



*Existing Cylindrical Shaft Piers - Van White Memorial Blvd. Bridge*

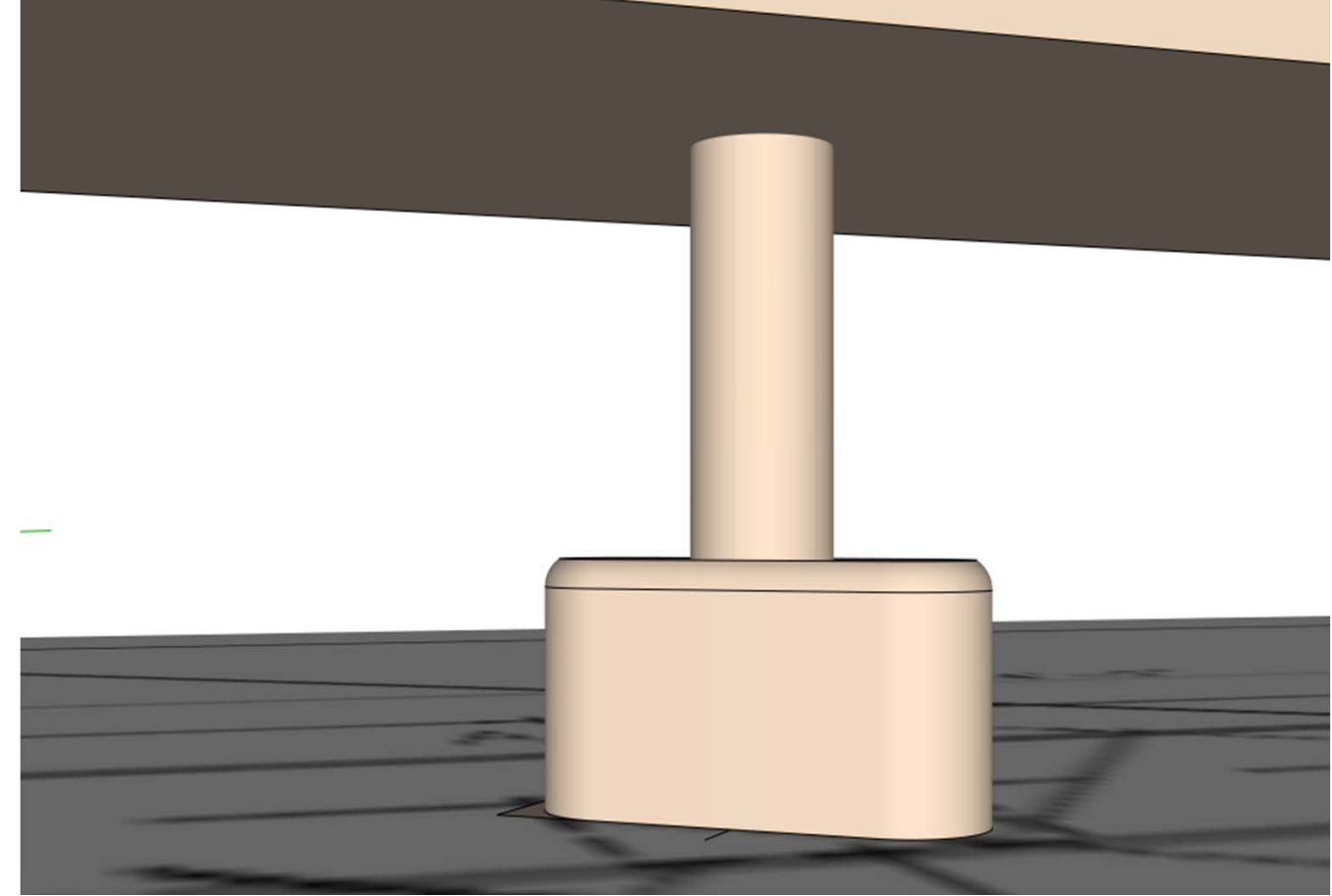

*Proposed Pier Protection - Van White Memorial Blvd. Bridge*

#### Design Notes

The existing piers supporting the Van White Memorial Blvd. Bridge are simple cylindrical shafts. The introduction of pier protection is necessary for one of these piers. Efforts could be undertaken to soften lines of the crash protection wall in response to the cylindrical shaft column. The use of similar radial nose and softened radius top of protection wall would integrate the column and the protection wall. Apply special surface treatment on crash protection barrier to match bridge substructure color. Apply anti-graffiti coating to crash barrier surfaces. Horizontal reveals common to other crash walls are not used at this location.



## 4.0 Pedestrian Tunnel Pilasters

### Design Notes

- Pilaster dimensions 2' wide with 6" offset from face of tallest wall texture.
- 1/2" chamfers all exterior edges
- Recess station name over tunnel opening 10" tall and 3/4" deep, center both horizontally and vertically over opening, font to be determined
- Paint all letter surfaces black
- Adjust tunnel frame width to each location
- Cast pilaster and lintel as complete units with out horizontal joints
- Lintel and Pilasters may be separate castings

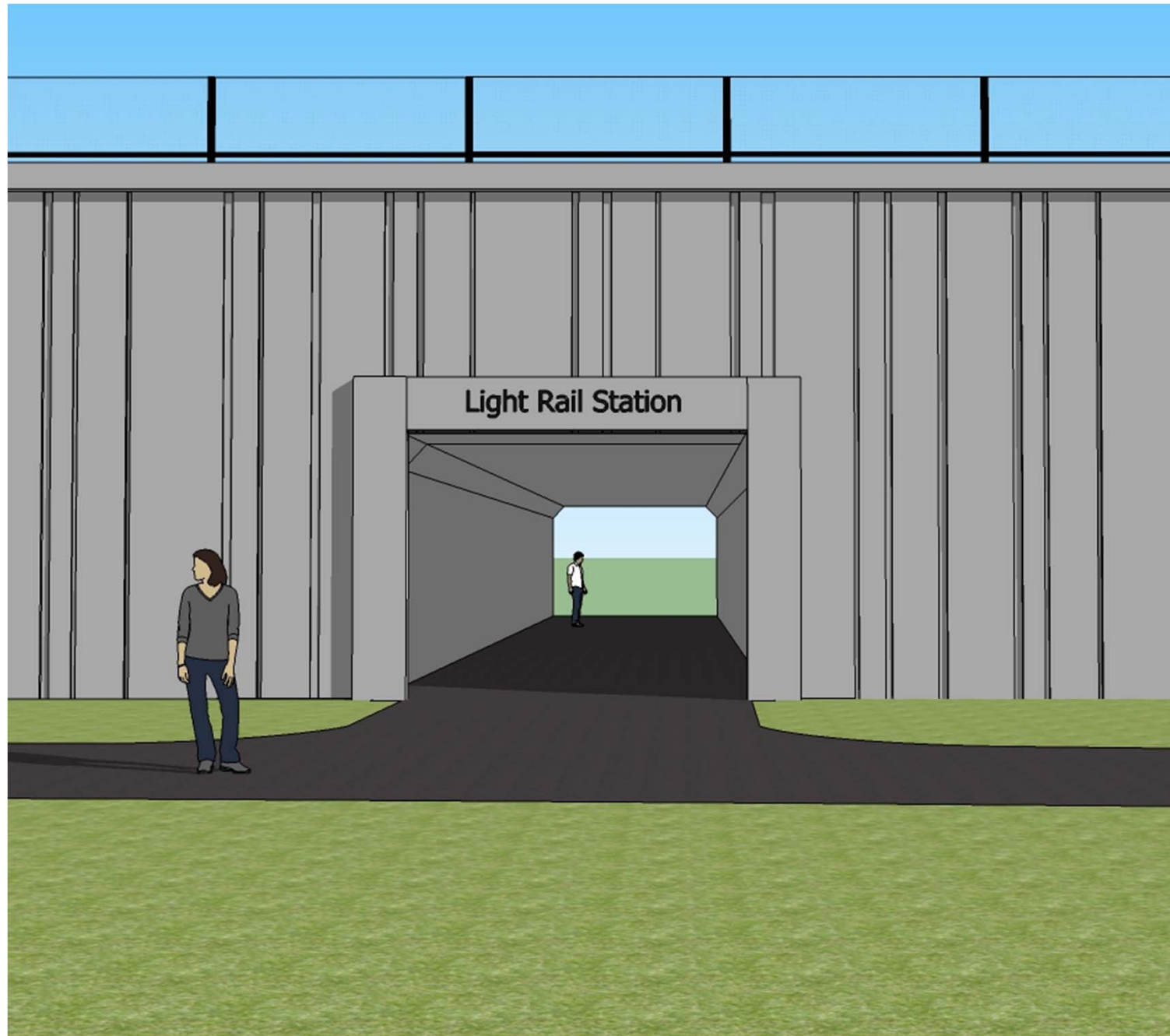

*Elevation*

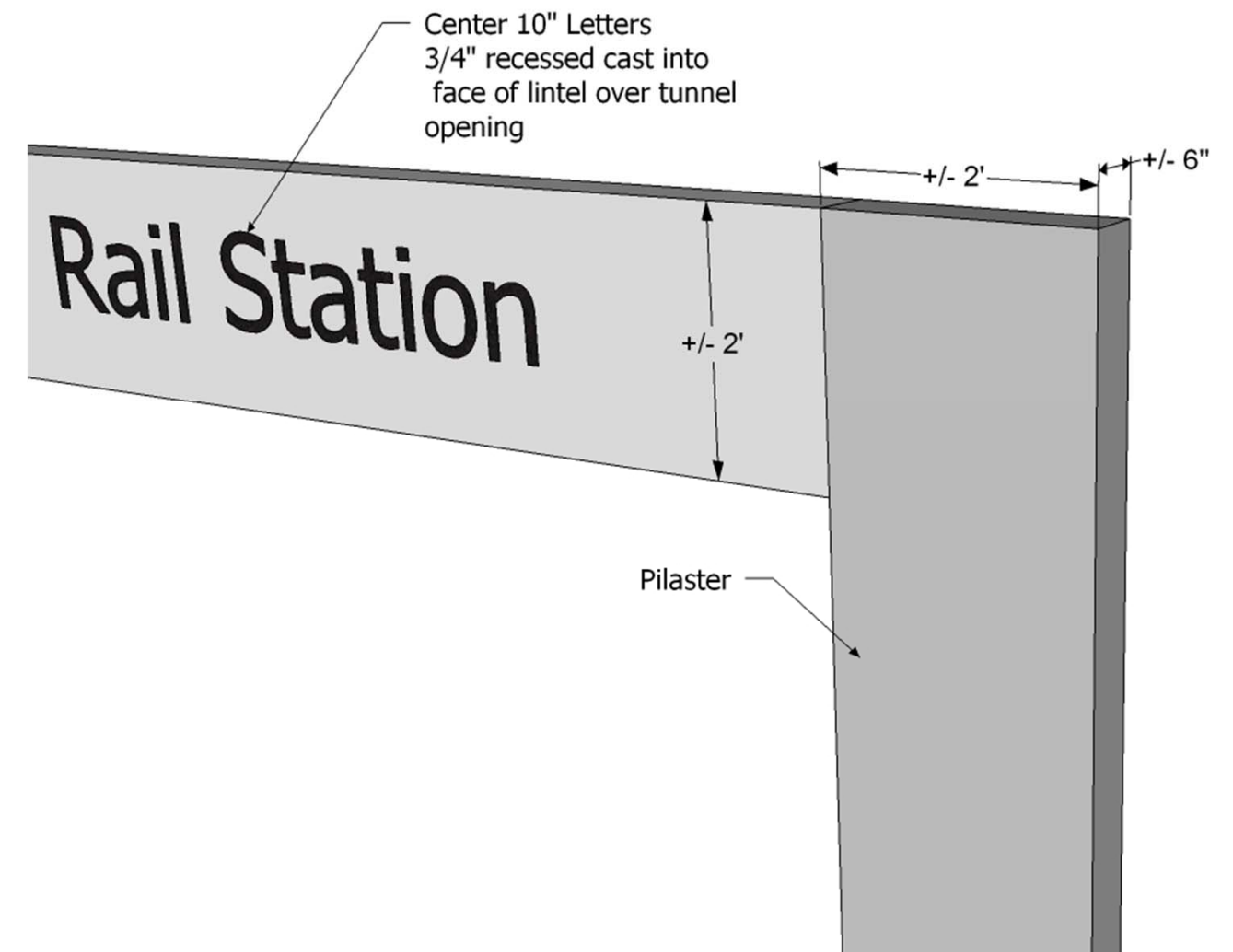

*Detail*

# 5.1.1 Retaining wall, abutment and wing wall textures

The following 6 textures have been selected for application to express local context while maintaining an overall corridor wide aesthetic.

In addition to the texture pattern, the base design for all exposed surfaces of retaining walls are to receive the application of either architectural surface finish or special surface finish per MnDOT standard specifications. See color palette for corridor wide color. In specific locations, the color palette of the MnDOT corridor will take precedence or walls within those locations. LRCI enhancements from a local community might also add color treatments above and beyond the single corridor color.

Wall textures 1-3 are intended for general use in the corridor for abutment walls, wing walls, and retaining walls. The textures were chosen based upon the following criteria.

- Simple patterns which provide an appropriate level of visual interest
- Timeless design
- Style neutral
- Cost effective
- Pattern will maintain character after application of MnDOT surface finish coating
- Favor geometric forms which do not mimic other natural materials
- Appropriate for variable wall heights

Wall textures 4-6 are intended for limited use on feature walls principally associated within LRT station sites and limited portions of other retaining walls with high visibility. The following criteria were considered in the selection of these textures.

- Distinct patterns which can provide a unique identity and way finding for a LRT station or location
- Strong geometric forms patterns which are compatible and complimentary with station the LRT station architecture
- Patterns which have visual interest
- Cost effective, and if possible from a standard form liner product line
- Pattern will maintain character after application of MnDOT surface finish coating

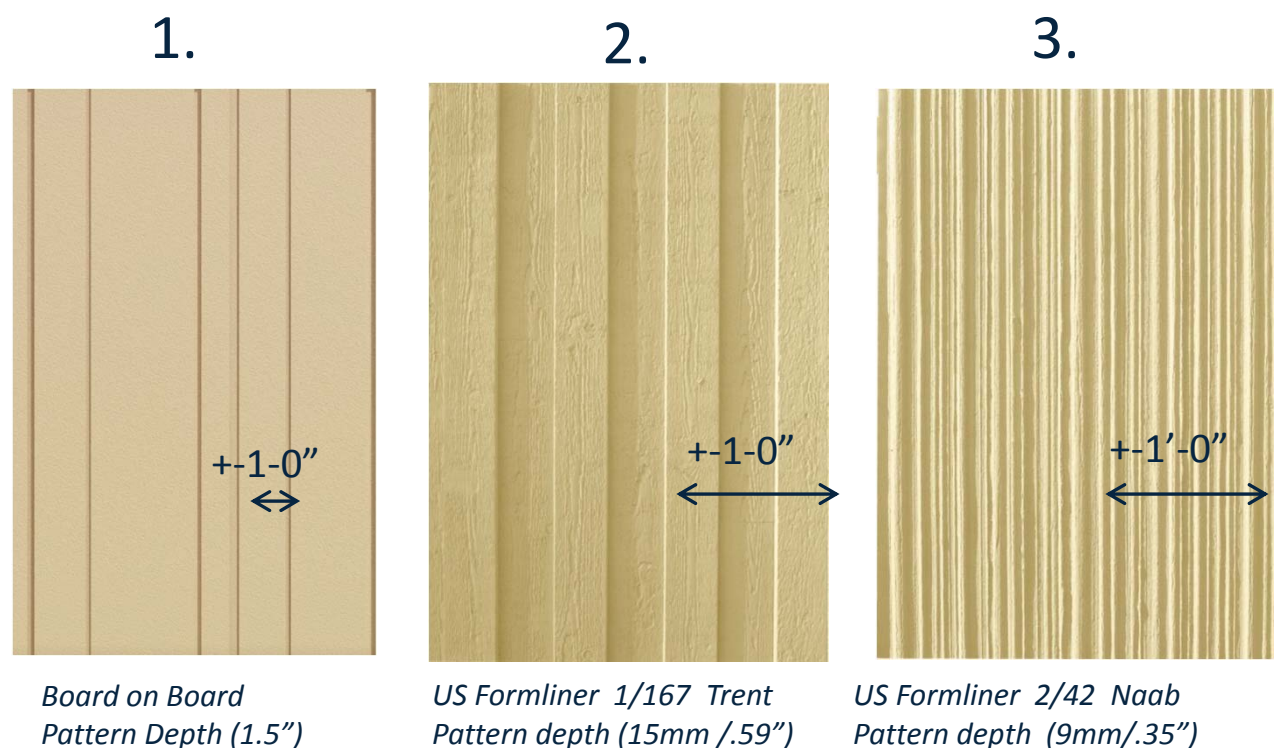

Primary Corridor Wall Textures 1-3

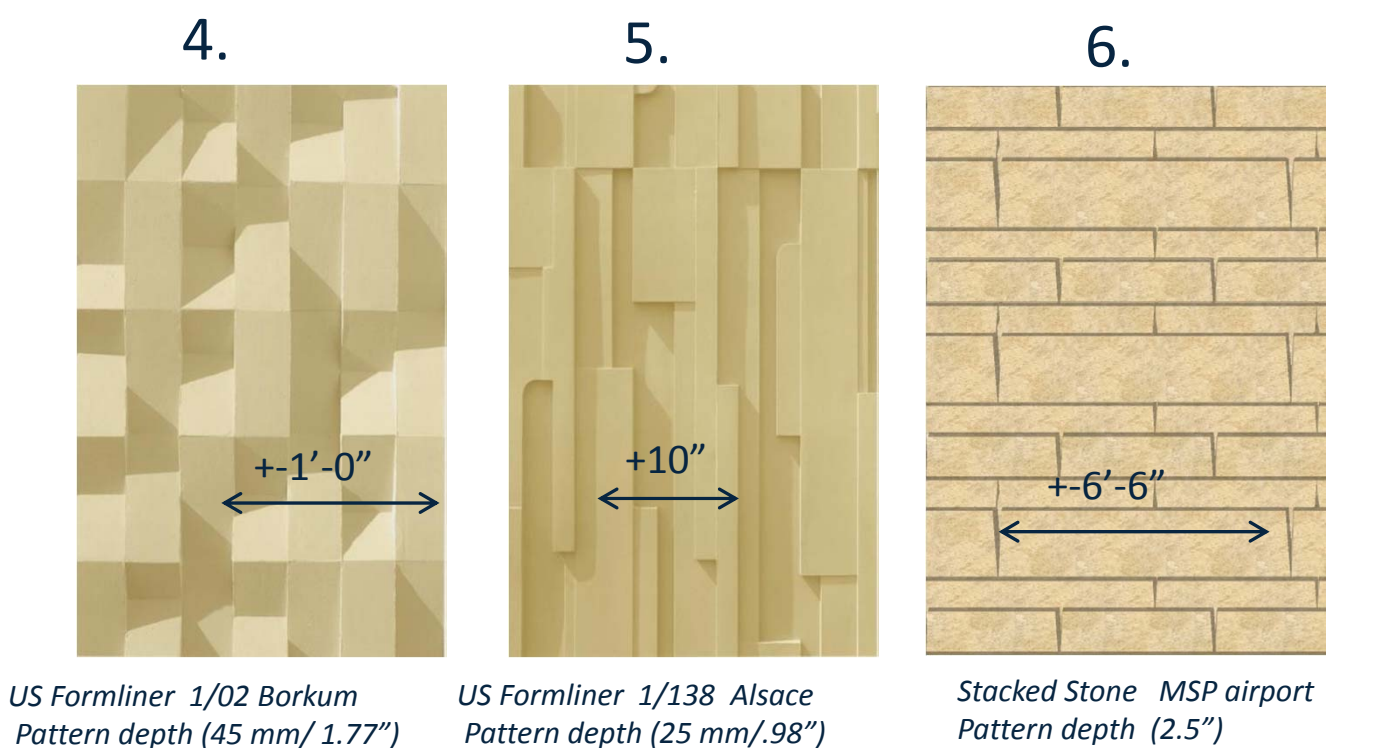

4,5,6 may be used horizontally

Feature Wall Textures 4-6



## 5.1.2 Retaining wall, abutment and wing wall textures- Glenwood Ave.

In the Glenwood Ave. LRT corridor it is recommended that a simpler more contextually appropriate wall pattern be used. This treatment consists of a simple rustication grid +- 4'x8' applied to all new retaining walls, wing walls and bridge abutment faces. This pattern will be similar to other wall treatments within this location and will be common to the bridge pier protection which is immediately adjacent to the Glenwood Ave. The standard wall coping is to be used on all walls.

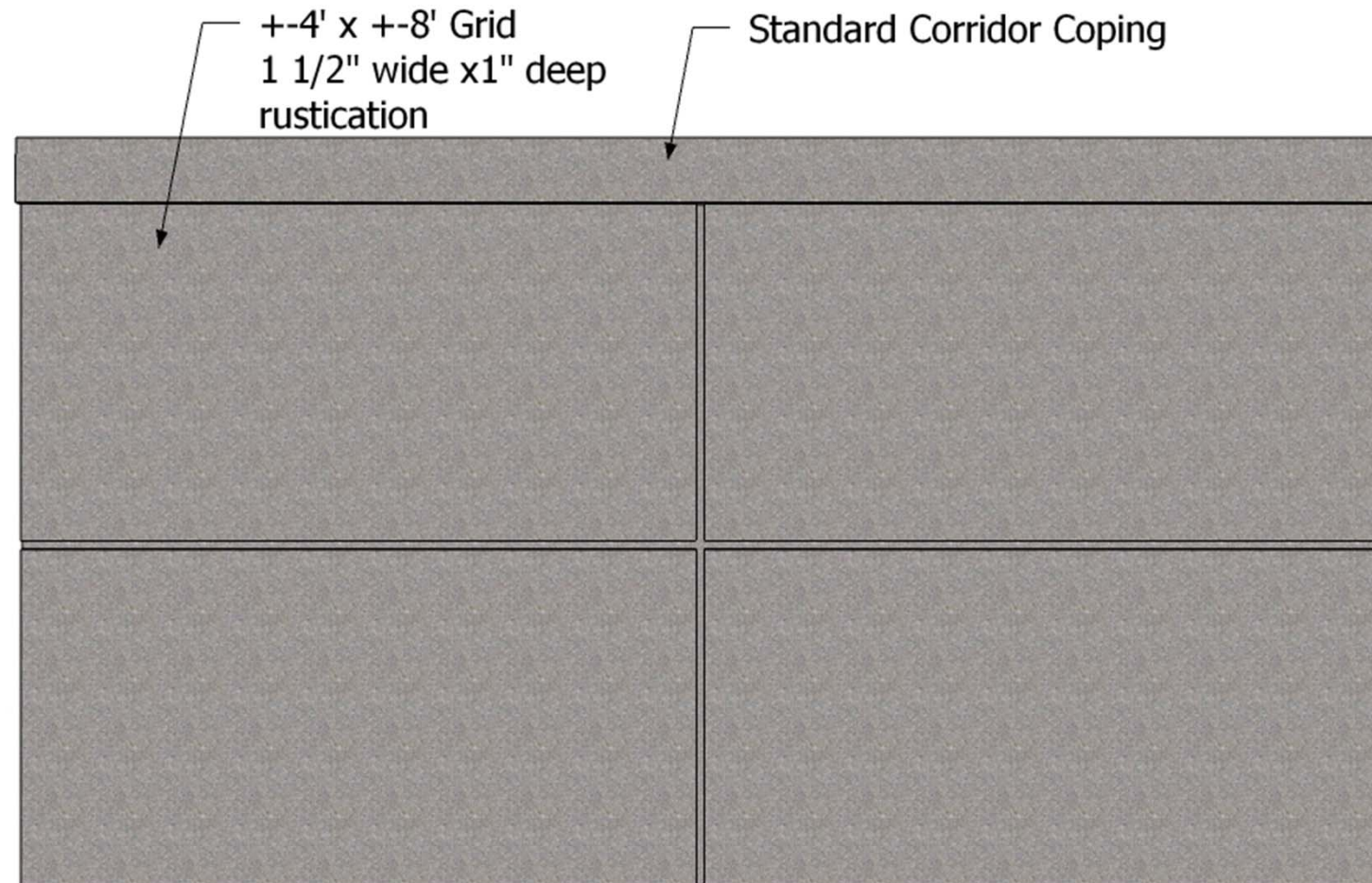

*Glenwood Ave. Corridor Wall Treatment - Elevation View*



*Existing Royalston Ave. - North Bridge abutment at Cedar Lake Trail*



*Existing Royalston Ave. - South Bridge abutment and retaining wall at Cedar Lake Trail*



## 5.1.2 Retaining wall, abutment and wing wall textures- Glenwood Ave.

On the north side of the Glenwood Ave. LRT corridor where new north facing walls adjoin the existing retaining walls it is recommended that a matching vertical pattern be used for any adjacent north facing retaining wall. Surface of wall to receive special surface finish in gray to match existing walls to remain.



*Existing Glenwood Ave. Corridor Wall Treatment – North Elevation View*



## 5.1.3 Retaining wall and bridge abutment face coping

Site retaining walls, wing walls and bridge abutment faces shall have a common coping as detailed below.

In locations where the wing wall abuts a retaining wall the retaining wall coping will be used on the wing wall.

Coping face is intended to be 2" outside the outer most projection of wall surface texture pattern. See 5.1.1 for discussion concerning surface finish.

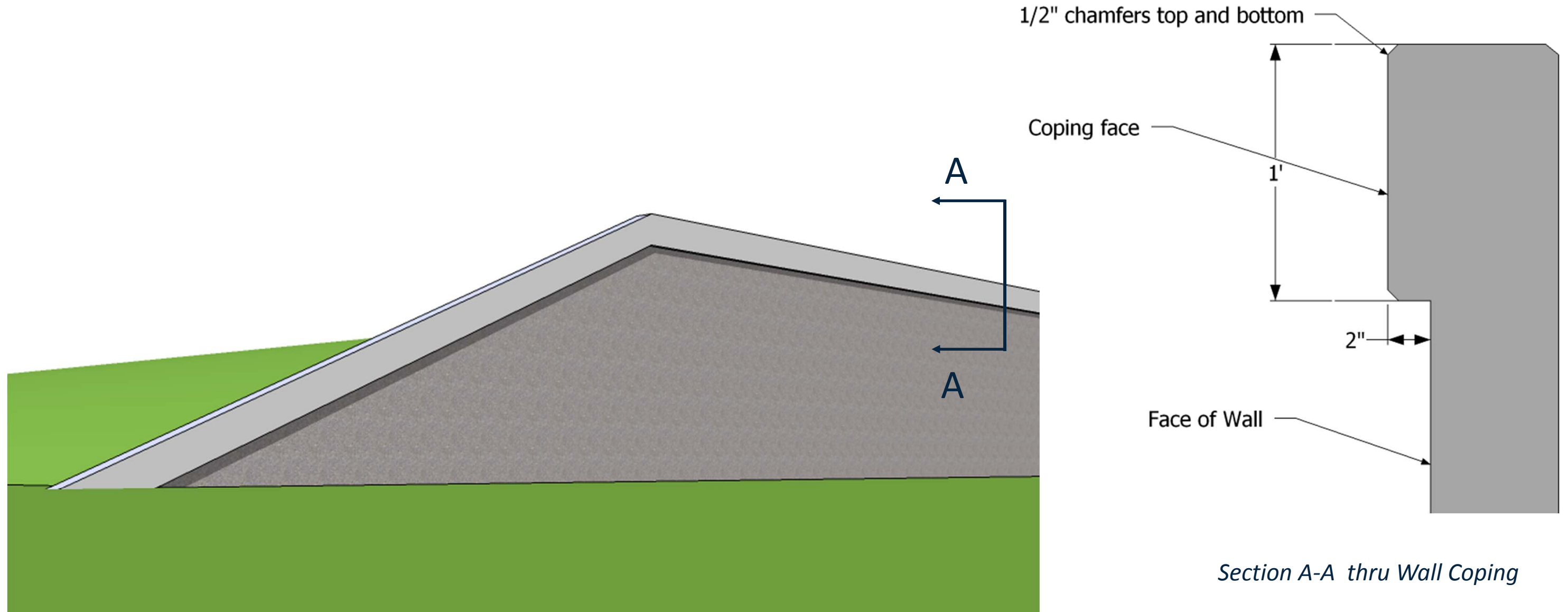

*Perspective of Typical Site Retaining Wall*

## 5.1.4 Minor Off System Retaining walls

At locations outside the confines of the defined LRT corridor minor site retaining wall improvements may be needed. In these locations, for walls of 30" or less in height the following surfacing and detailing is to be used. The determination Regarding the need for safety railing will be determined on a case by case basis and where necessary the standard safety rail will be used. Determination regarding the use of the other corridor or special wall textures for off corridor walls will be made on a case by case basis. See summary of wall treatments for locations.

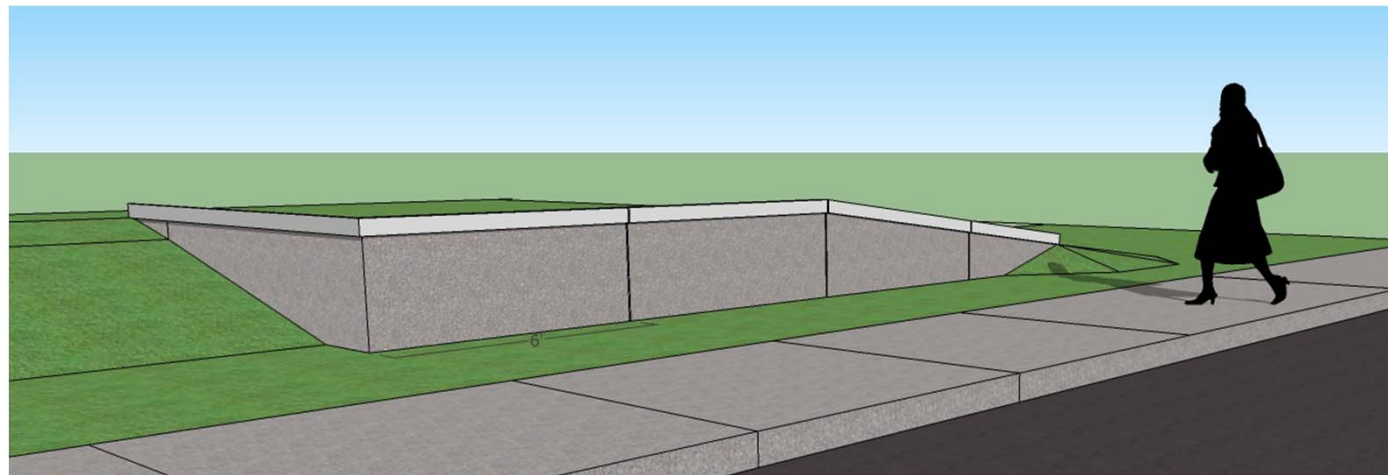

*Small Site Wall - Perspective*

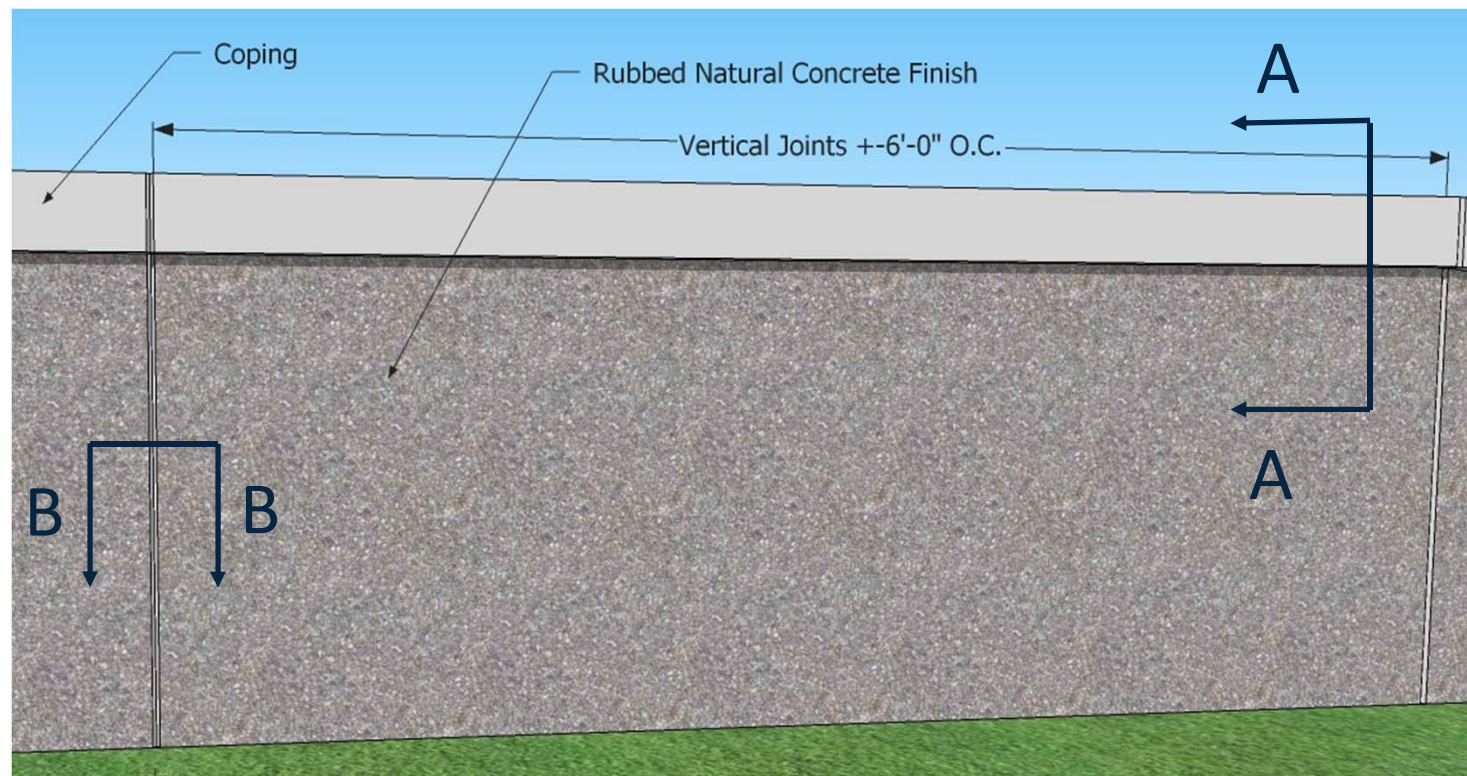

*Small Site Wall - Elevation*

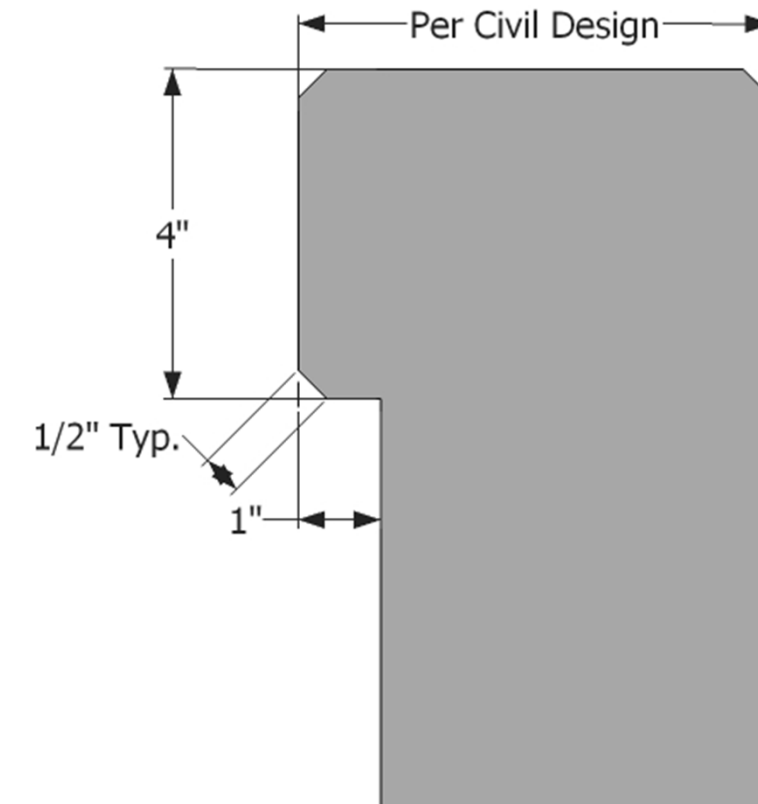

*Section A-A Thru Wall Coping*

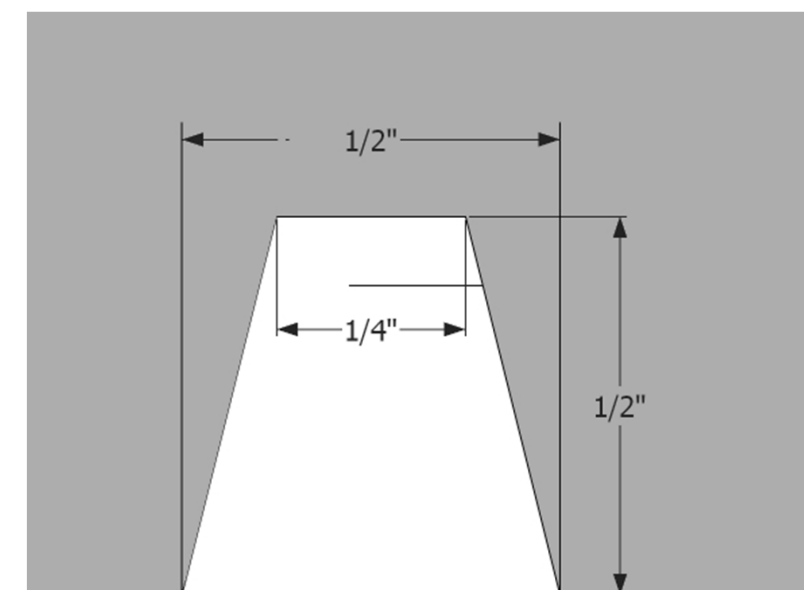

*Plan B-B Vertical Joints*



## 6.0 Fencing and Safety Rail



*Example of Diamond mesh safety Rail on LRT bridge*



*Example of safety fence on pedestrian bridge*

Fall protection requirements for the LRT corridor will necessitate the installation of safety fencing to a minimum height of 42" above the walking surface on all LRT bridge decks, bridge wing walls and site retaining walls in excess of 30" above adjacent grade. For other facilities such as trail bridges the prevailing code requirements for heights shall govern for those locations. All fencing will be diamond mesh unless otherwise indicated on drawings.

The base design materials for all fencing on the project shall consist of the following:

- 2" pattern diamond mesh woven wire fabric
- Vertical Pipe Post
- Top and Bottom Pipe Rail
- Black Vinyl Coating on all materials
- Drill in surface flange mounting atop bridge curb/parapet and wall coping.

## 6.1 Diamond Mesh Safety Rail

The minimum height for safety and fall protection is 42" above the egress walk surface. This height is established to meet the code requirements and is not established for aesthetic purposes. The height of the fencing may be adjusted to accommodate standard woven wire fabric widths if this is deemed to be in the best interest of the project. Post spacing may be adjusted to more easily follow radial bridge decks and accommodate expansion joints, and other similar conditions. Both curb heights and safety rail heights may vary depending upon bridge parapet height and specific uses such as trail uses and or the need for additional rail road or vehicle roadway protection. All safety fencing will be black coated tubular metal framing and 2" diamond mesh woven wire fabric with black color. The determination concerning the inclusion of top rail will be made during final design.

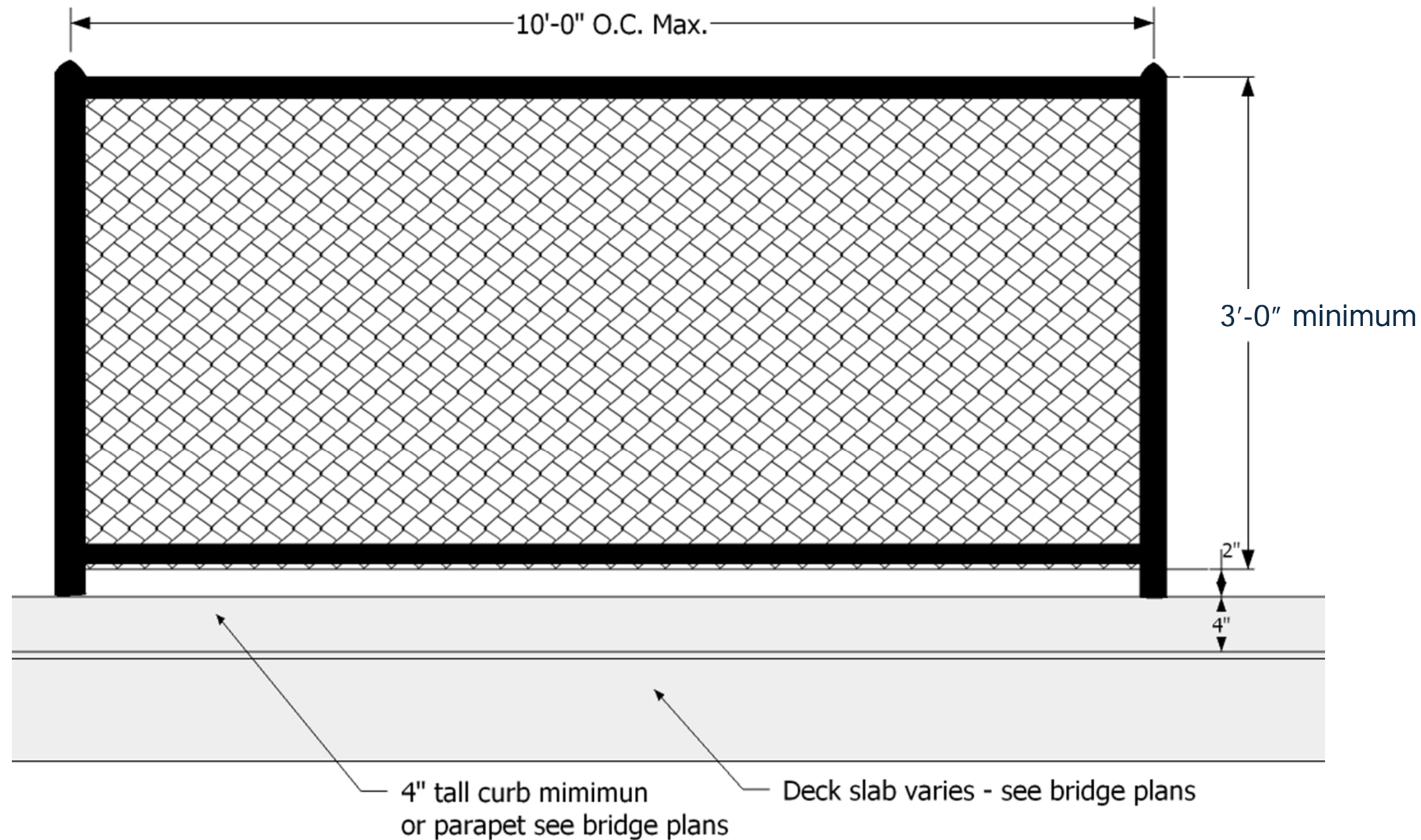

*Elevation – Standard Safety Railing*



## 7.0 Color Palette

The use of color on the SWLRT structures is intended to be limited to a single color applied uniformly to all exterior LRT, freight and trail structures, walls, and bridges. The application of the color will be per MnDOT standard specifications for the element to receive the color surface finished. Railings and safety fencing will be colored black, the means of which will be determined during final design. Exceptions to this approach will include any structures which are located within MnDOT established aesthetic corridors in which case the color palette of the controlling corridor will be followed. It is possible that an alternative color may be chosen to better fit within the context of other nearby infrastructure such as the improvements adjacent to the Glenwood Ave. bridge and the 5<sup>th</sup> and 7<sup>th</sup> Ave. bridge which connects to the LRT structure at the “Interchange “. In addition, portions of bridges or walls may be given an accent color which has been requested as part of a Locally Requested Capital Investment ( LRCI). These alternative color selections will be directed via the LRCI process and will not be a part of this document.

**FINAL COLOR SELECTION  
IS IN PROGRESS**



# 8.0 Summary Of Aesthetics Application - Roll Plots

The following roll plots document the preliminary aesthetic choices and treatments to be used on the major structures of the corridor. The roll plots identify the application of the Base Design and as such is a starting point for the Advanced Design Consultants. It is anticipated that as the final designs advance and local communities are consulted, there may be changes to the treatments as summarized on the roll plots. Guidance for these changes will be communicated as output from the Advance Design Meeting(ADM) or specific LRCI design development.

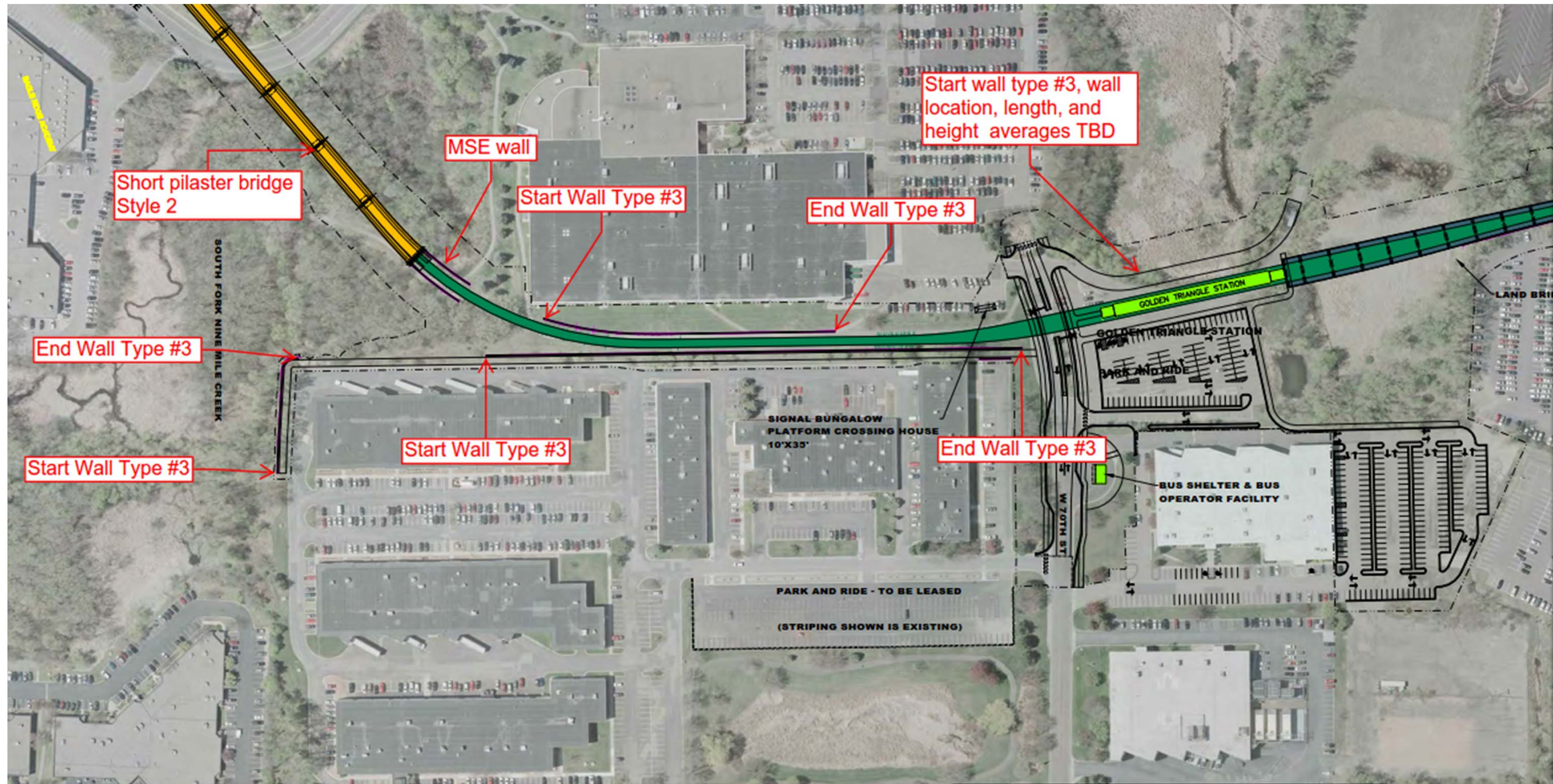

COLOR LEGEND

<span style="color: green;">█</span> LRT TRACK AREA	<span style="color: orange;">█</span> TUNNEL
<span style="color: yellow;">█</span> STATION PLATFORM	<span style="color: red;">█</span> BRIDGE
<span style="color: red;">█</span> RETAINING WALL	

SOUTHWEST LRT ALIGNMENT  
SEGMENT W2 – EDEN PRAIRIE